

Off-Line Current Source Controller

Introduction

The Supertex HV9906DB2 demo board contains all circuitry necessary to demonstrate the features of the HV9906 second order power supply controller. The power converter of the demo board consists of an input buck-boost stage and an output buck stage. The output voltage polarity is negative. Due to its unique quadratic input-to-output DC voltage transfer ratio, the converter can operate directly off AC line to produce low-voltage output without need for electrolytic capacitors. HV9906 is designed for optimal controlling this type of power converter or other types of two-stage multi-converters.

The board is optimized for driving a 6V 400mA (700mA max.) LED. However, it may be modified to meet custom requirements.

Specification

Input Voltage	80 to 135VAC, 60Hz
Output Current	400mA \pm 10% (700mA max.)
Output Voltage	10V max.
Efficiency	62% at $I_o=500mA, V_{in}=100VAC$

Board Layout and Connections

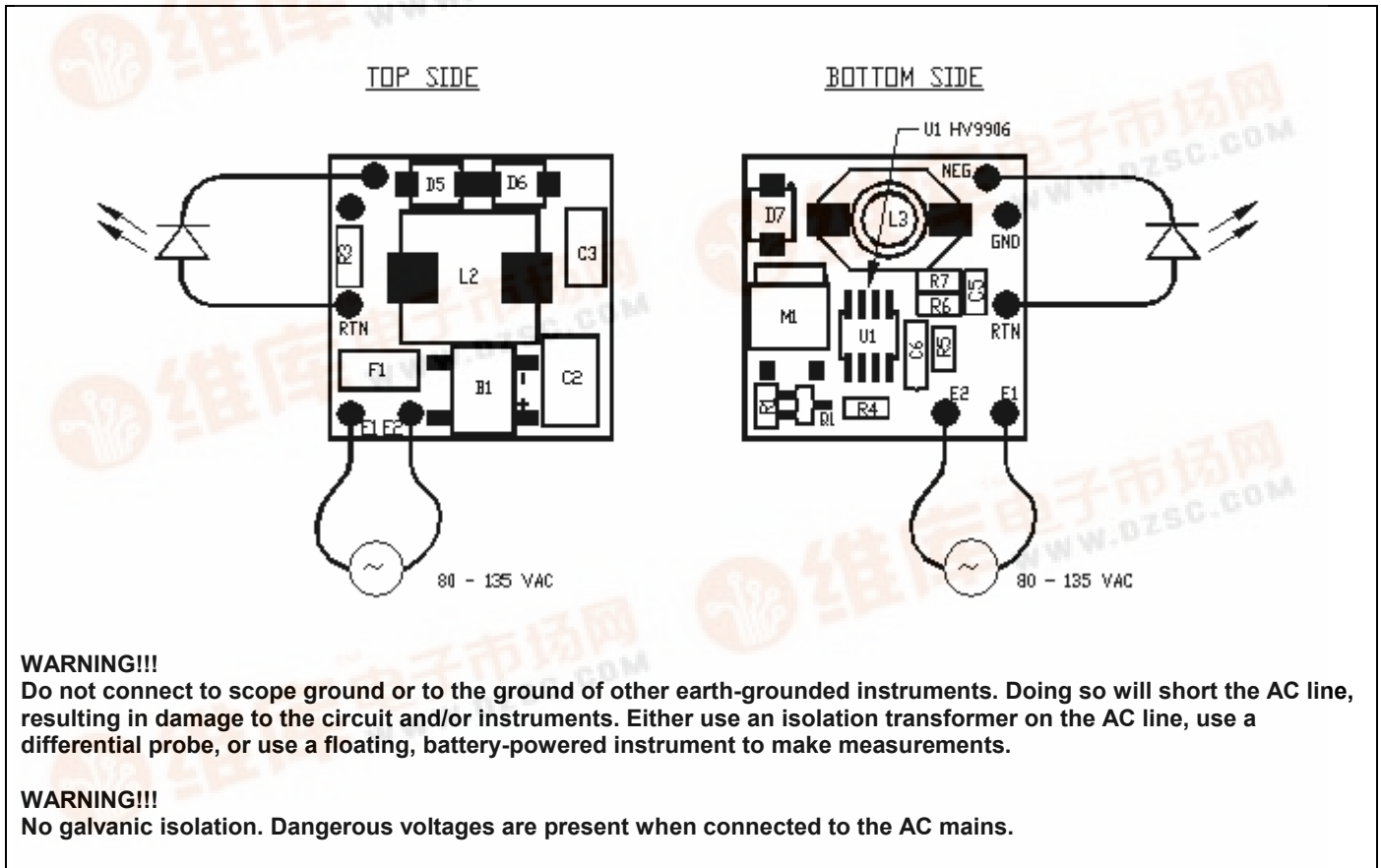

Instructions

NEG, RTN

Connect your LED to these terminals: negative to NEG, positive to RTN.

E1, E2

Connect 80 to 135VAC, 60Hz line source to these terminals: line to E1, neutral to E2. The input is protected with a 0.5A fuse. **IMPORTANT: Make sure that your LED is connected to NEG and RTN terminals. There is no open circuit protection available in this demo board. Contact Supertex, Inc. for the application circuit if protection is required.**

GND

This is circuit common.

Note that since galvanic isolation is not provided, connecting this point to an earth-grounded instrument

(such as an oscilloscope) will short the AC line, resulting in circuit and/or instrument damage.

Also note that GND may be at higher potential with respect to earth ground, even if the AC is switched off. Use caution!

Do not connect to earth-ground.

Setting Output Current

Output current is preset to 400mA for this board. Output current can be re-programmed according to the following equation:

$$I_{out} = \frac{R6 - R7}{R7 \cdot R3} \cdot 1V$$

The average output current will come out 5-10% smaller due to power transfer interruptions during the AC line voltage cusps.

Schematic Diagram

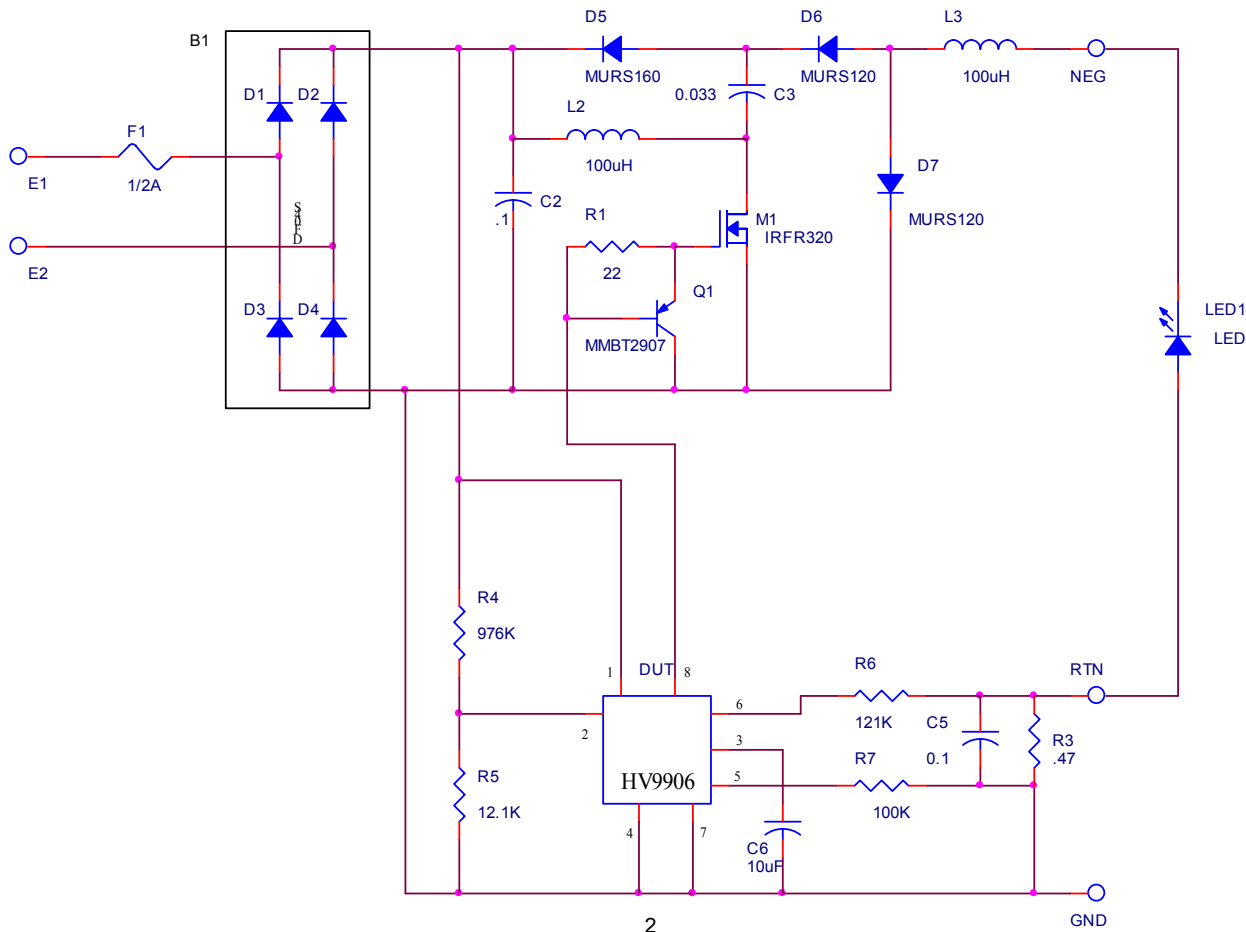

HV9906DB2

Parts List

Item	Reference	Part	Part Number	Manufacturer	Part No.
1	B1	Diode Bridge	DF04S	Diodes Inc.	DF04S
2	C2	Cap, PEN Film 0.1uF 250V	ECW-U2104KC9	Panasonic	ECW-U2104KC9
3	C3	Cap, PEN Film 0.033uF 250V	ECW-U2333KC9	Panasonic	ECW-U2333KC9
4	C5	0.1 uF, 50V, 10%			
5	C6	10 uF, 16V Tantalum Chip			
6	D5	Diode, Ultra Fast, 600V 1A	MURS160T3	On Semi	MURS160T3
7	D6	Diode, Ultra Fast, 200V 1A	MURS120T3	On Semi	MURS120T3
8	D7	Diode, Ultra Fast, 200V 1A	MURS120T3	On Semi	MURS120T3
9	F1	Fuse, 1/2A, Slow Blow	R452.500	Littelfuse	R452.500
10	L2	100uH, 1.7A	CTCDRH127-101	Central Technologies	CTCDRH127-101
11	L3	100uH, 1.2A	DO3316P-104	Coilcraft	DO3316P-104
12	M1	MOSFET, 400V	IRFR320	International Rectifier	IRFR320
13	Q1	BJT, PNP	MMBT2907	On Semi	MMBT2907
14	R1	22 ohm, 1%, 1/8W			
15	R3	0.47 ohm, 1%, 1/4W			
16	R4	976K ohm, 1%, 1/8W			
17	R5	12.1K ohm, 1%, 1/8W			
18	R6	121K ohm, 1%, 1/8W			
19	R7	100K ohm, 1%, 1/8W			
20	U1	PWM/PFM IC	HV9906	Supertex, Inc.	HV9906

The Supertex SuperNova Powers the Luxeon Star™

- Highlights:**
- 400mA (700mA when potted)
 - Small **25mm x 25mm x 11mm** size
 - High reliability
 - No electrolytic capacitors
 - Operates directly off AC line (85VAC V_{in} <math>< 135VAC</math>)
 - Maintains regulation down to 20VDC input

PCB Layout:

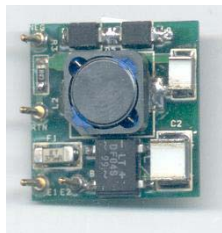

Fig. 1 - Top view

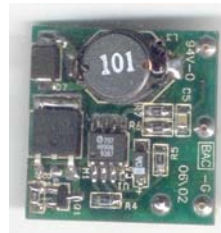

Fig. 2 - Bottom view

Waveforms:

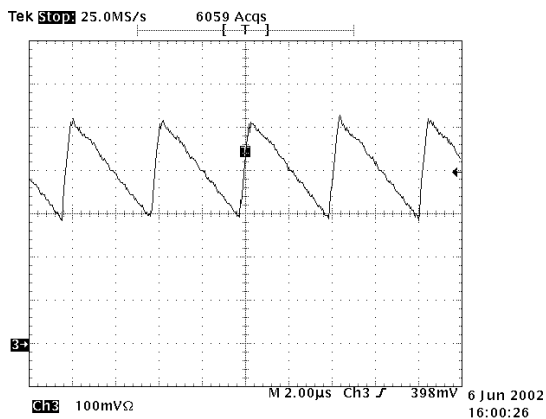

Fig. 3 - Output Current ($V_{in} = 120VDC$)

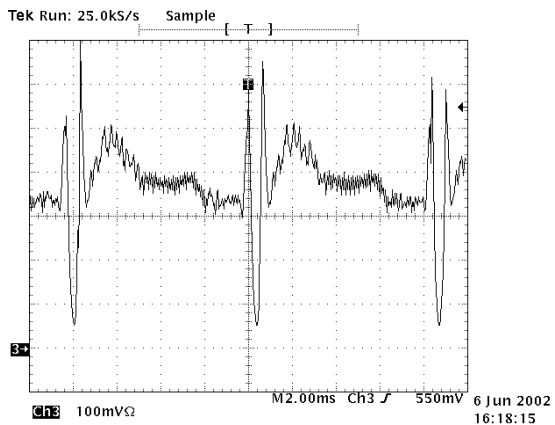

Fig. 4 - Output Current ($V_{in} = 120AC$)

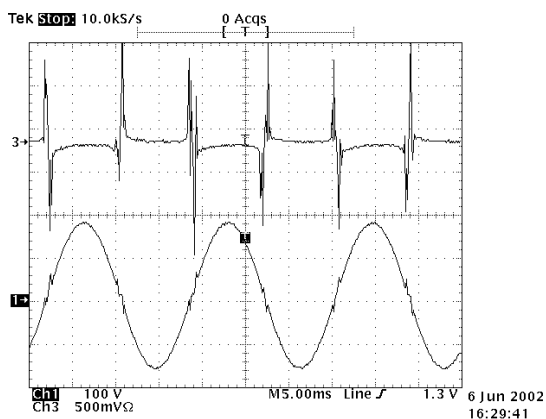

Fig. 5 - Input Current and Voltage ($V_{in} = 120VAC$)

Waveform Summary:

Fig. 3 shows continuous nature of the output current. Peak-to-average current ratio is close to unity.

Fig. 4 shows that current drops out of regulation for short periods of time only during the AC line cusps. (Switching ripple component is attenuated for clarity.)

Fig. 5 shows the input current nature. The converter delivers full output power to the output down to very low input voltage.