

## Off-Line PFC Current Source Controller

### Introduction

The Supertex HV9906DB3 demo board is a power factor corrected (PFC) LED driver using the HV9906 IC. A power converter of the demo board consists of an input buck-boost stage and an output buck stage. The output voltage polarity is negative. Due to its unique quadratic input-to-output DC voltage transfer ratio, the converter can operate directly off AC line to produce low-voltage output without need for electrolytic capacitors. The HV9906 is designed for optimally controlling this type of a power converter or other types of two-stage multi-converters.

HV9906DB3 demo board features passive power factor correction to PF>0.95. The board is optimized for driving a 500mA (700mA max.) LED array. (Forced cooling or encapsulation is required to achieve an output current higher than 500mA.)

### Features

- Off-Line Transformerless Power Conversion
- Power Factor Correction to PF>0.95
- Soft Start
- Low Inrush Current on Start

### Specification

Input Voltage	80 to 135VAC, 47-63 Hz or 100 to 200VDC
Output Current	500mA ±10% (700mA max.)
Output Voltage	10V max.
Power Factor	>0.95
Total AC Line Harmonic Distortion (THD)	<15%
Efficiency	60% (Vo=10V, Io=0.5A, Vin=100VAC)

### Board Layout and Connections

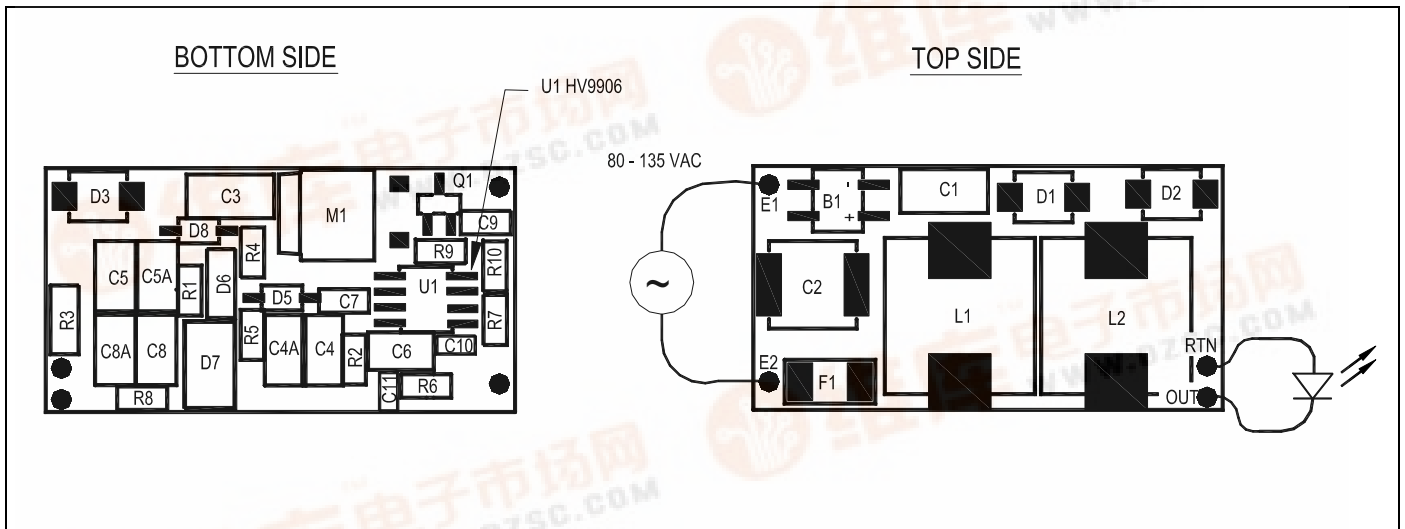

**WARNING!!!**  
Do not connect to scope ground or to the ground of other earth-grounded instruments. Doing so will short the AC line, resulting in damage to the circuit and/or instruments. Either use an isolation transformer on the AC line, use a differential probe, or use a floating, battery-powered instrument to make measurements.

**WARNING!!!**  
No galvanic isolation. Dangerous voltages are present when connected to the AC mains.



**Instructions**

**OUT, RTN**

Connect your LED to these terminals. Make sure that it is connected in the polarity shown on the diagram above.

**E1, E2**

Connect 80 to 135VAC line source to these terminals. The input is fuse protected to 0.5A.

**Setting Output Current**

Output current is preset to 500mA for this board. Output current can be re-programmed by selecting R3 according to the following equation:

$$I_{OUT} = \frac{R6 + R1 + R8 - R7}{R7 \cdot R3} \cdot 1V$$

However, the board must be forced cooled or encapsulated using thermally conductive encapsulant to operate continuously at output current higher than 500mA.

**Schematic Diagram**

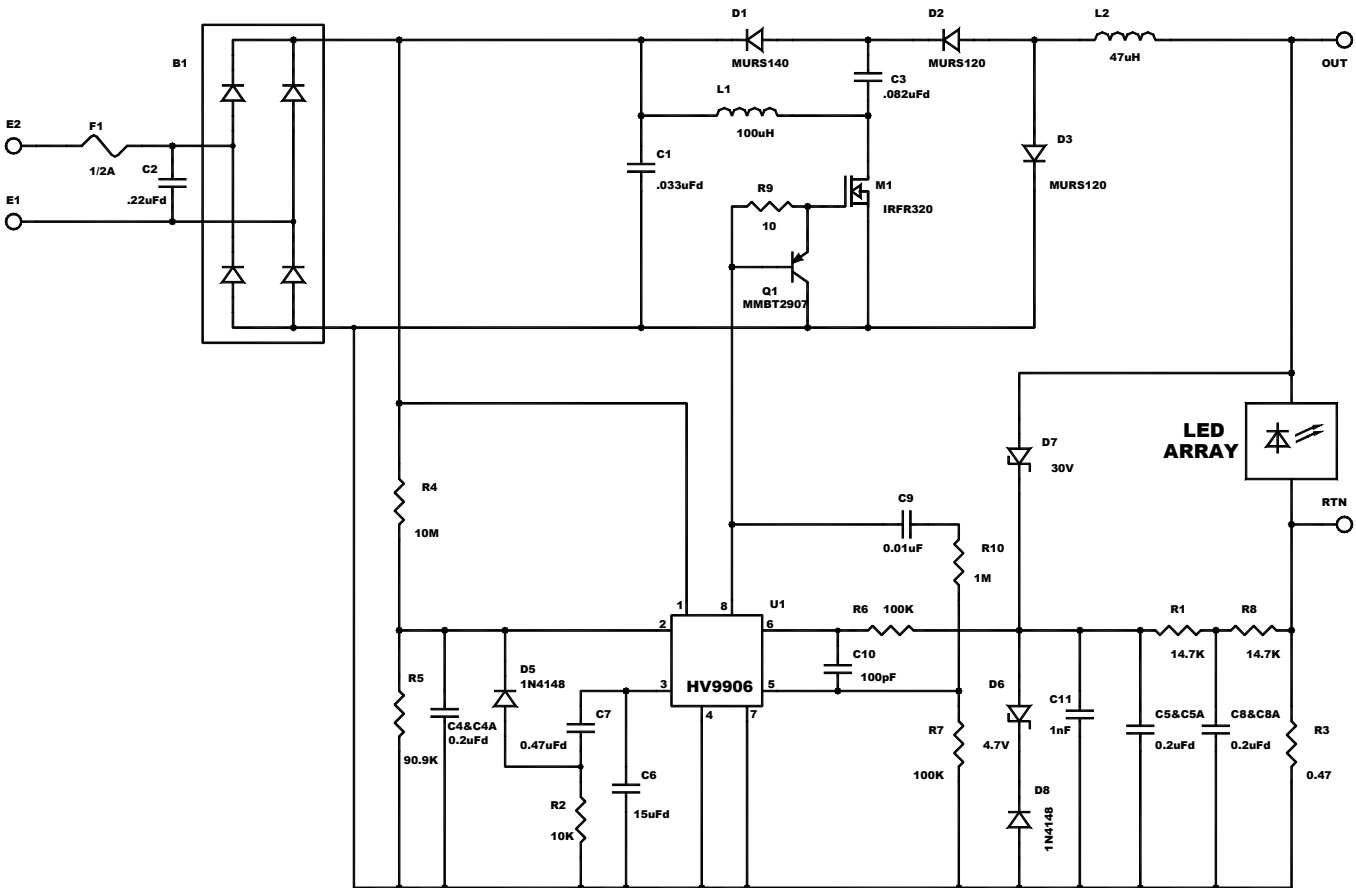

C4&C4A, C5&C5A, C8&C8A are two 0.1uF capacitors in parallel.

## Part List

Item	Reference	Part	Package	Manufacturer	Part No.
1	B1	Diode Bridge	SMD DF-S	Diodes Incorporated or equivalent	DF04S
2	C1	0.033 uF, 100V, 10%	SMD1913	Panasonic Pen Film	ECW-U2333KC9
3	C2	0.22uF, 250V, 10%	SMD2825	Panasonic Pen Film	ECW-U2224KCV
4	C3	0.082 uF, 100V, 10%	SMD1913	Panasonic Pen Film	ECW-U1823KC9
5	C4	0.1uF, 16V, 5%	SMD1210	Panasonic PPS Film	ECH-U1C104JB5
6	C4A	0.1uF, 16V, 5%	SMD1210	Panasonic PPS Film	ECH-U1C104JB5
7	C5	0.1uF, 16V, 5%	SMD1210	Panasonic PPS Film	ECH-U1C104JB5
8	C5A	0.1uF, 16V, 5%	SMD1210	Panasonic PPS Film	ECH-U1C104JB5
9	C6	15 uF, 16V, 10%, Tantalum	SMD3528	Kemet or equivalent	
10	C7	0.47uF Ceramic X7R 16V	SMD0805	Panasonic or equivalent	
11	C8	0.1uF, 16V, 5%	SMD1210	Panasonic PPS Film	ECH-U1C104JB5
12	C8A	0.1uF, 16V, 5%	SMD1210	Panasonic PPS Film	ECH-U1C104JB5
13	C9	0.01uF, 50V	SMD0805	Panasonic or equivalent	
14	C10	100pF, NPO, 50V	SMD0603	Panasonic or equivalent	
14	C11	1000pF, NPO, 50V	SMD0603	Panasonic or equivalent	
15	D1	Ultra Fast, 400V, 1A	SMB	On Semi or equivalent	MURS140T3
16	D2	Ultra Fast, 200V, 1A	SMB	On Semi or equivalent	MURS120T3
17	D3	Ultra Fast, 200V, 1A	SMB	On Semi or equivalent	MURS120T3
18	D5	1N4148	SOD123	On Semi or equivalent	1N4148
19	D6	Zener, 4.7V	SMD DL-35	Diodes Inc. or equivalent	ZMM5230B
20	D7	Zener, 30V	SMD DL-41	Diodes Inc. or equivalent	ZM4751A
21	D8	1N4148	SOD123	On Semi or equivalent	1N4148
22	F1	1/2A, Slow Blow	SMD2410	Littlefuse	R452.500
23	L1	100uH, 1.7A	SMD	Sumida	CDRH127-101MC
24	L2	47uH, 1.8A	SMD	Sumida	CDRH125-470MC
25	M1	MOSFET, 400V, 3.1A	D-Pak	International Rectifier	IRFR320
26	Q1	BJT, PNP	SOT23	On Semi or equivalent	MMBT2907
27	R1	14.7K ohm, 1%	SMD0805	Panasonic or equivalent	
28	R2	10.0K Ohm, 1%	SMD0805	Panasonic or equivalent	
29	R3	0.47 ohm, 5%	SMD1206	Panasonic or equivalent	
30	R4	10.0M Ohm, 1%	SMD0805	Panasonic or equivalent	
31	R5	90.9K ohm, 1%	SMD0805	Panasonic or equivalent	
32	R6	100K ohm, 1%	SMD0805	Panasonic or equivalent	
33	R7	100K ohm, 1%	SMD0805	Panasonic or equivalent	
34	R8	14.7K ohm, 1%	SMD0805	Panasonic or equivalent	
35	R9	10.0 Ohm, 1%	SMD0805	Panasonic or equivalent	
36	R10	1.0M Ohm, 1%	SMD0805	Panasonic or equivalent	
37	U1	PWM/PFM IC	SOIC8	Supertex, Inc.	HV9906