



July 2003

# LM2591HV

## SIMPLE SWITCHER® Power Converter 150 kHz 1A

### Step-Down Voltage Regulator

#### General Description

The LM2591HV series of regulators are monolithic integrated circuits that provide all the active functions for a step-down (buck) switching regulator, capable of driving a 1A load with excellent line and load regulation. These devices are available in fixed output voltages of 3.3V, 5V, and an adjustable output version.

This series of switching regulators is similar to the LM2590HV, but without some of the supervisory and performance features of the latter.

Requiring a minimum number of external components, these regulators are simple to use and include internal frequency compensation†, improved line and load specifications and a fixed-frequency oscillator.

The LM2591HV operates at a switching frequency of 150 kHz thus allowing smaller sized filter components than what would be needed with lower frequency switching regulators. Available in a standard 5-lead TO-220 package with several different lead bend options, and a 5-lead TO-263 Surface mount package.

Other features include a guaranteed ±4% tolerance on output voltage under all conditions of input voltage and output load conditions, and ±15% on the oscillator frequency. External shutdown is included, featuring typically 90 µA standby current. Self protection features include a two stage

current limit for the output switch and an over temperature shutdown for complete protection under fault conditions.

#### Features

- 3.3V, 5V, and adjustable output versions
- Adjustable version output voltage range, 1.2V to 57V ±4% max over line and load conditions
- Guaranteed 1A output load current
- Available in 5-pin TO-220 and TO-263 (surface mount) Package
- Input voltage range up to 60V
- 150 kHz fixed frequency internal oscillator
- On/Off control
- Low power standby mode,  $I_Q$  typically 90 µA
- High Efficiency
- Thermal shutdown and current limit protection

#### Applications

- Simple high-efficiency step-down (buck) regulator
- Efficient pre-regulator for linear regulators
- On-card switching regulators
- Positive to Negative converter

Note: † Patent Number 5,382,918.

#### Typical Application (Fixed Output Voltage Versions)

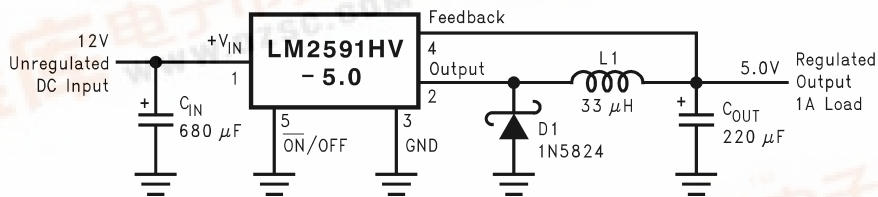

10129301

LM2591HV SIMPLE SWITCHER Power Converter 150 kHz 1A Step-Down Voltage Regulator



**Absolute Maximum Ratings** (Note 1)

If Military/Aerospace specified devices are required, please contact the National Semiconductor Sales Office/Distributors for availability and specifications.

Maximum Supply Voltage ( $V_{IN}$ )	63V
$\overline{ON}$ /OFF Pin Voltage	$-0.3 \leq V \leq +25V$
Feedback Pin Voltage	$-0.3 \leq V \leq +25V$
Output Voltage to Ground (Steady State)	-1V
Power Dissipation	Internally limited
Storage Temperature Range	$-65^{\circ}C$ to $+150^{\circ}C$
ESD Susceptibility	

Human Body Model (Note 2)	2 kV
Lead Temperature	
S Package	
Vapor Phase (60 sec.)	$+215^{\circ}C$
Infrared (10 sec.)	$+245^{\circ}C$
T Package (Soldering, 10 sec.)	$+260^{\circ}C$
Maximum Junction Temperature	$+150^{\circ}C$

**Operating Conditions**

Temperature Range	$-40^{\circ}C \leq T_J \leq +125^{\circ}C$
Supply Voltage	4.5V to 60V

### LM2591HV-3.3

#### Electrical Characteristics

Specifications with standard type face are for  $T_J = 25^{\circ}C$ , and those with **boldface type** apply over **full Operating Temperature Range**.

Symbol	Parameter	Conditions	LM2591HV-3.3		Units (Limits)
			Typ (Note 3)	Limit (Note 4)	
<b>SYSTEM PARAMETERS</b> (Note 5) Test Circuit <i>Figure 1</i>					
$V_{OUT}$	Output Voltage	$4.75V \leq V_{IN} \leq 60V, 0.2A \leq I_{LOAD} \leq 1A$	3.3	3.168/ <b>3.135</b> 3.432/ <b>3.465</b>	V V(min) V(max)
$\eta$	Efficiency	$V_{IN} = 12V, I_{LOAD} = 1A$	77		

### LM2591HV-5.0

#### Electrical Characteristics

Specifications with standard type face are for  $T_J = 25^{\circ}C$ , and those with **boldface type** apply over **full Operating Temperature Range**.

Symbol	Parameter	Conditions	LM2591HV-5.0		Units (Limits)
			Typ (Note 3)	Limit (Note 4)	
<b>SYSTEM PARAMETERS</b> (Note 5) Test Circuit <i>Figure 1</i>					
$V_{OUT}$	Output Voltage	$7V \leq V_{IN} \leq 60V, 0.2A \leq I_{LOAD} \leq 1A$	5	4.800/ <b>4.750</b> 5.200/ <b>5.250</b>	V V(min) V(max)
$\eta$	Efficiency	$V_{IN} = 12V, I_{LOAD} = 1A$	82		%

### LM2591HV-ADJ

#### Electrical Characteristics

Specifications with standard type face are for  $T_J = 25^{\circ}C$ , and those with **boldface type** apply over **full Operating Temperature Range**.

Symbol	Parameter	Conditions	LM2591HV-ADJ		Units (Limits)
			Typ (Note 3)	Limit (Note 4)	
<b>SYSTEM PARAMETERS</b> (Note 5) Test Circuit <i>Figure 1</i>					
$V_{FB}$	Feedback Voltage	$4.5V \leq V_{IN} \leq 60V, 0.2A \leq I_{LOAD} \leq 1A$ $V_{OUT}$ programmed for 3V. Circuit of <i>Figure 1</i> .	1.230	1.193/ <b>1.180</b> 1.267/ <b>1.280</b>	V V(min) V(max)
$\eta$	Efficiency	$V_{IN} = 12V, V_{OUT} = 3V, I_{LOAD} = 1A$	76		%



## All Output Voltage Versions Electrical Characteristics (Continued)

**Note 11:** Junction to ambient thermal resistance (no external heat sink) for the package mounted TO-220 package mounted vertically, with the leads soldered to a printed circuit board with (1 oz.) copper area of approximately 1 in<sup>2</sup>.

**Note 12:** Junction to ambient thermal resistance with the TO-263 package tab soldered to a single sided printed circuit board with 0.5 in<sup>2</sup> of (1 oz.) copper area.

**Note 13:** Junction to ambient thermal resistance with the TO-263 package tab soldered to a single sided printed circuit board with 2.5 in<sup>2</sup> of (1 oz.) copper area.

**Note 14:** Junction to ambient thermal resistance with the TO-263 package tab soldered to a double sided printed circuit board with 3 in<sup>2</sup> of (1 oz.) copper area on the LM2591HVS side of the board, and approximately 16 in<sup>2</sup> of copper on the other side of the p-c board. See application hints in this data sheet and the thermal model in **Switchers Made Simple** available at <http://power.national.com>.

## Typical Performance Characteristics (Circuit of Figure 1)

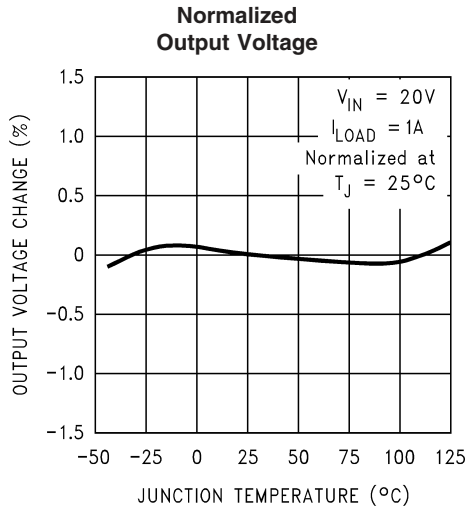

10129302

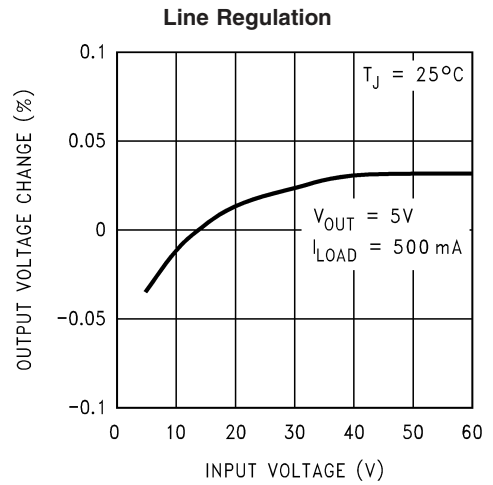

10129303

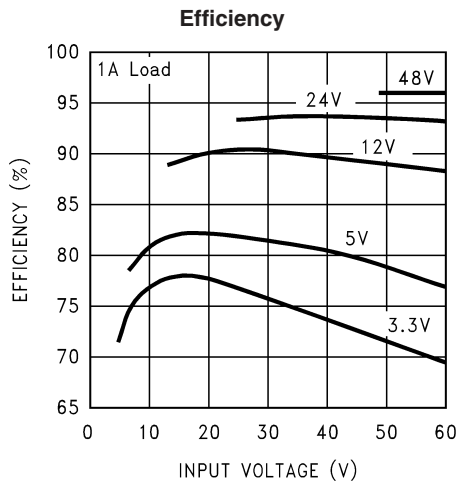

10129304

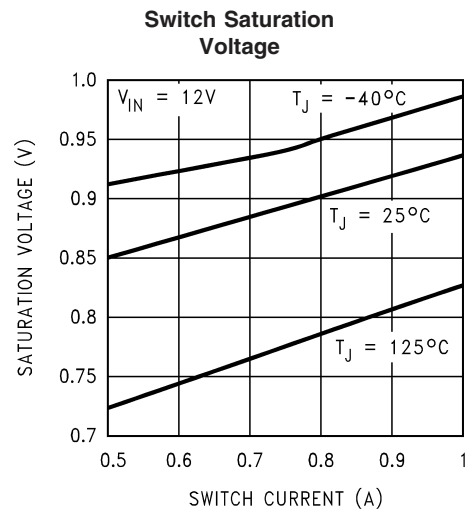

10129305

**Typical Performance Characteristics** (Circuit of Figure 1) (Continued)

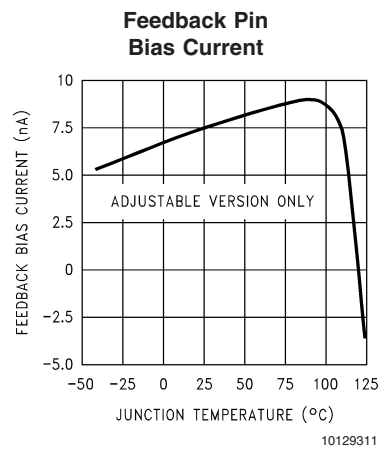
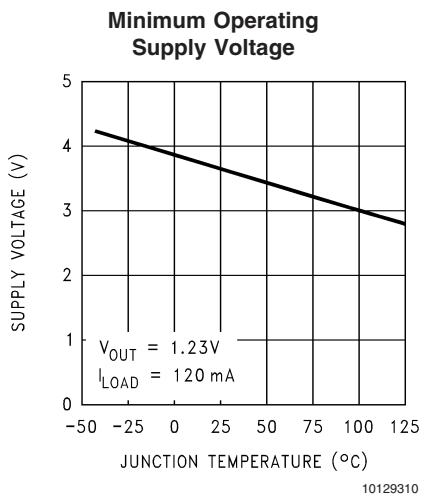
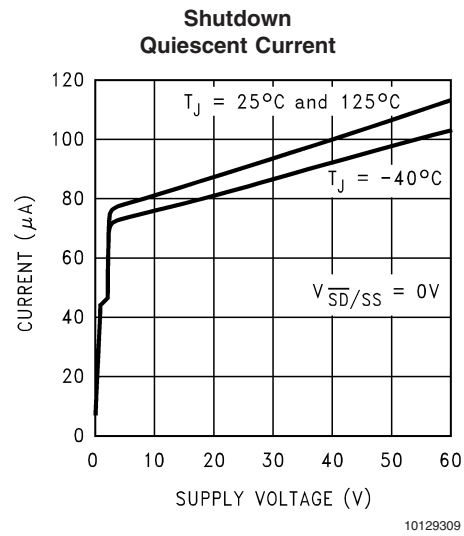
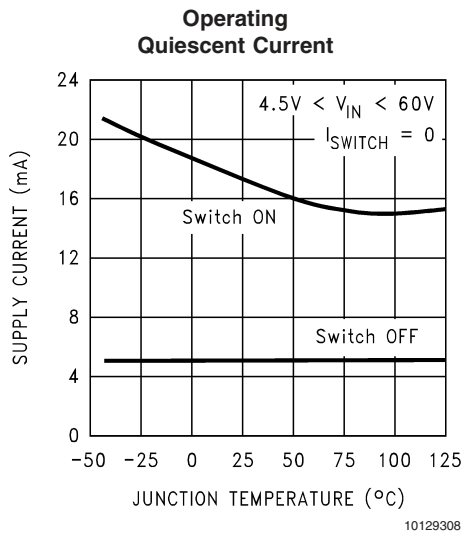
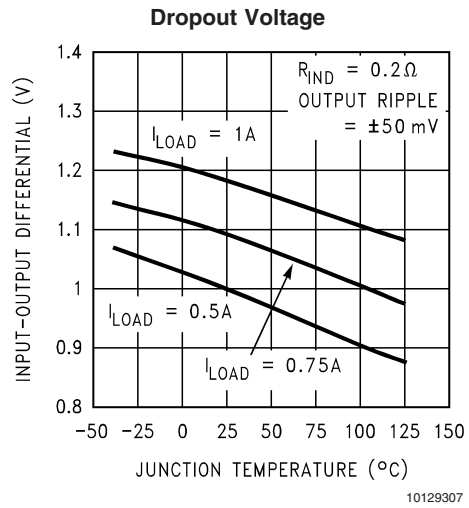
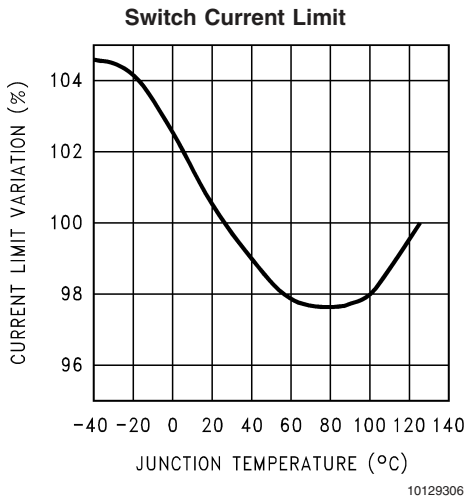

## Typical Performance Characteristics (Circuit of Figure 1) (Continued)

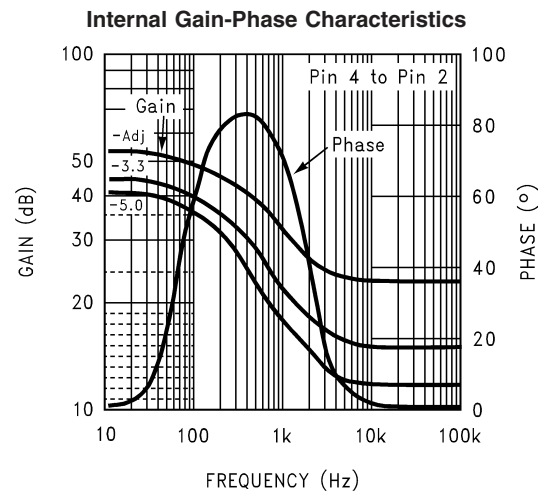
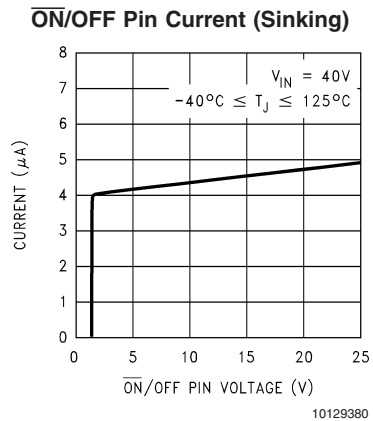
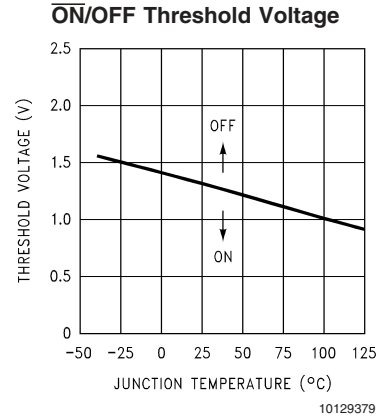
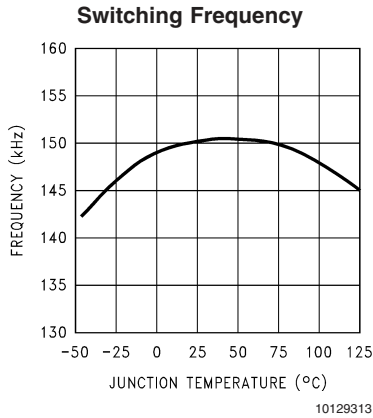

**Continuous Mode Switching Waveforms**  
 $V_{IN} = 20V, V_{OUT} = 5V, I_{LOAD} = 1A$   
 $L = 52 \mu H, C_{OUT} = 100 \mu F, C_{OUT} ESR = 100 m\Omega$

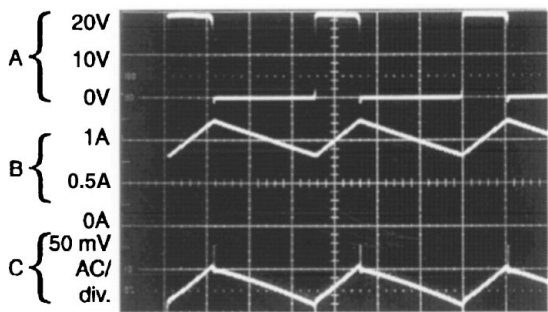

A: Output Pin Voltage, 10V/div.  
 B: Inductor Current 0.5A/div.  
 C: Output Ripple Voltage, 50 mV/div.

**Horizontal Time Base: 2 µs/div.**

**Discontinuous Mode Switching Waveforms**  
 $V_{IN} = 20V, V_{OUT} = 5V, I_{LOAD} = 250 mA$   
 $L = 15 \mu H, C_{OUT} = 150 \mu F, C_{OUT} ESR = 90 m\Omega$

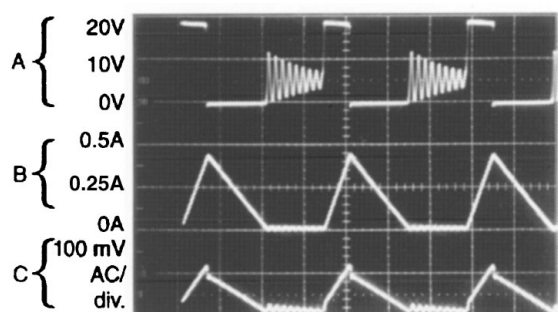

A: Output Pin Voltage, 10V/div.  
 B: Inductor Current 0.25A/div.  
 C: Output Ripple Voltage, 100 mV/div.

**Horizontal Time Base: 2 µs/div.**

## Typical Performance Characteristics (Circuit of Figure 1) (Continued)

**Load Transient Response for Continuous Mode**  
 $V_{IN} = 20V, V_{OUT} = 5V, I_{LOAD} = 250\text{ mA to }1A$   
 $L = 52\ \mu H, C_{OUT} = 100\ \mu F, C_{OUT}\ ESR = 100\ m\Omega$

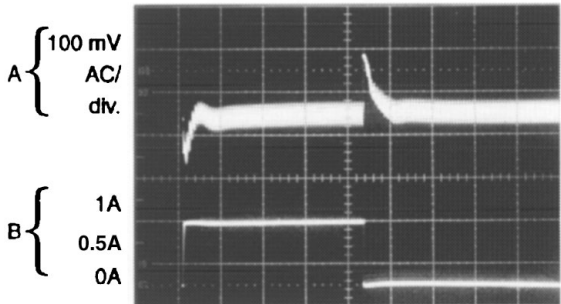

A: Output Voltage, 100 mV/div. (AC)  
 B: 250 mA to 1A Load Pulse

10129321

Horizontal Time Base: 50  $\mu s$ /div.

**Load Transient Response for Discontinuous Mode**  
 $V_{IN} = 20V, V_{OUT} = 5V, I_{LOAD} = 250\text{ mA to }1A$   
 $L = 15\ \mu H, C_{OUT} = 150\ \mu F, C_{OUT}\ ESR = 90\ m\Omega$

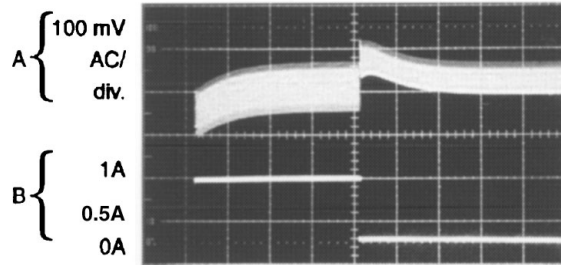

A: Output Voltage, 100 mV/div. (AC)  
 B: 250 mA to 1A Load Pulse

10129322

Horizontal Time Base: 200  $\mu s$ /div.

## Connection Diagrams and Order Information

**Bent and Staggered Leads, Through Hole Package**  
**5-Lead TO-220 (T)**

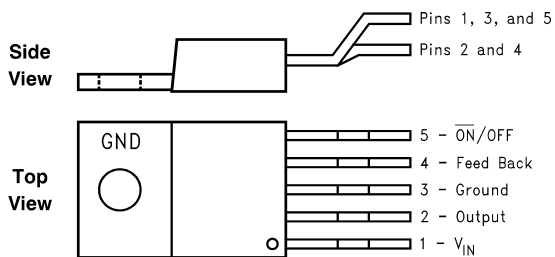

10129381

Order Number LM2591HVT-3.3, LM2591HVT-5.0,  
 or LM2591HVT-ADJ  
 See NS Package Number T05D

**Surface Mount Package**  
**5-Lead TO-263 (S)**

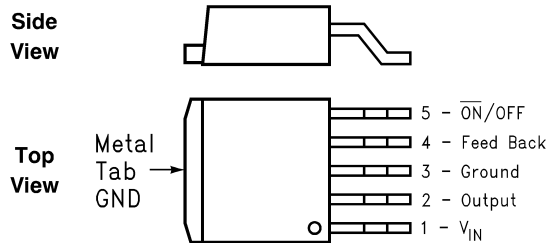

10129382

Order Number LM2591HVS-3.3, LM2591HVS-5.0,  
 or LM2591HVS-ADJ  
 See NS Package Number TS5B

## Test Circuit and Layout Guidelines

### Fixed Output Voltage Versions

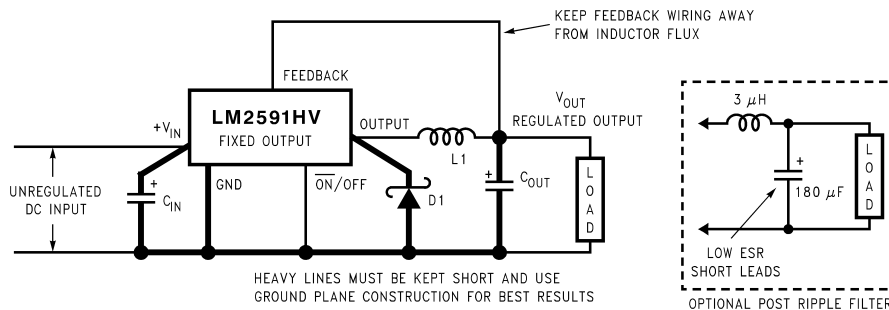

10129324

Component Values shown are for  $V_{IN} = 15V$ ,

$V_{OUT} = 5V$ ,  $I_{LOAD} = 1A$ .

$C_{IN}$  — 470  $\mu F$ , 50V, Aluminum Electrolytic Nichicon "PM Series"

$C_{OUT}$  — 220  $\mu F$ , 25V Aluminum Electrolytic, Nichicon "PM Series"

D1 — 2A, 60V Schottky Rectifier, 21DQ06 (International Rectifier)

L1 — 68  $\mu H$ , See Inductor Selection Procedure

### Adjustable Output Voltage Versions

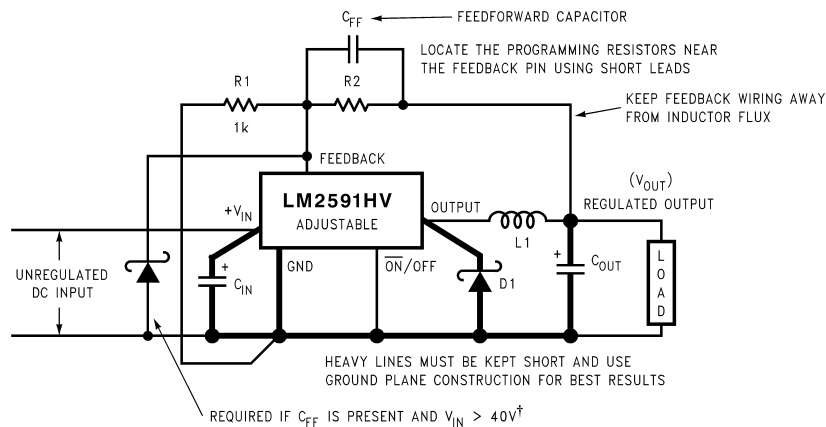

10129325

Select  $R_1$  to be approximately 1 k $\Omega$ , use a 1% resistor for best stability.

Component Values shown are for  $V_{IN} = 20V$ ,

$V_{OUT} = 10V$ ,  $I_{LOAD} = 1A$ .

$C_{IN}$ : — 470  $\mu F$ , 35V, Aluminum Electrolytic Nichicon "PM Series"

$C_{OUT}$ : — 220  $\mu F$ , 35V Aluminum Electrolytic, Nichicon "PM Series"

D1 — 2A, 60V Schottky Rectifier, 21DQ06 (International Rectifier)

L1 — 100  $\mu H$ , See Inductor Selection Procedure

$R_1$  — 1 k $\Omega$ , 1%

$R_2$  — 7.15k, 1%

$C_{FF}$  — 3.3 nF

*Typical Values*

$C_{SS}$  — 0.1  $\mu F$

$C_{DELAY}$  — 0.1  $\mu F$

$R_{PULL UP}$  — 4.7k (use 22k if  $V_{OUT}$  is  $\geq 45V$ )

† Small signal Schottky diode to prevent damage to feedback pin by negative spike when output is shorted ( $C_{FF}$  not being able to discharge immediately will drag feedback pin below ground). Required if  $V_{IN} > 40V$

FIGURE 1. Standard Test Circuits and Layout Guides



## Block Diagram

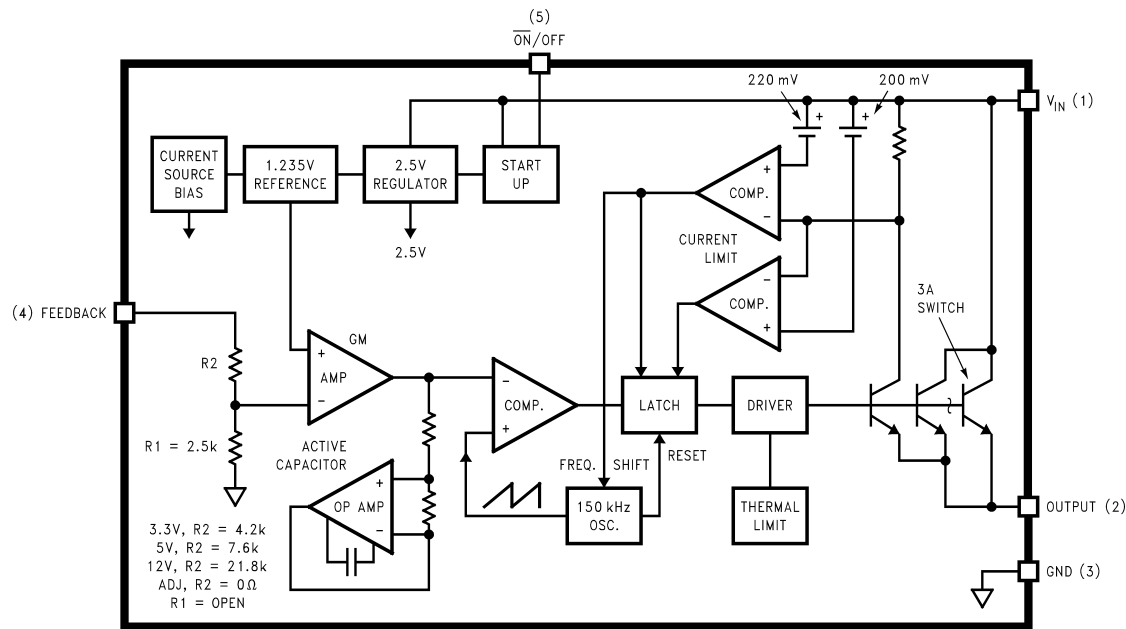

## Pin Functions

**+V<sub>IN</sub>** (Pin 1)—This is the positive input supply for the IC switching regulator. A suitable input bypass capacitor must be present at this pin to minimize voltage transients and to supply the switching currents needed by the regulator.

**Output** (Pin 2)—Internal switch. The voltage at this pin switches between approximately  $(+V_{IN} - V_{SAT})$  and approximately  $-0.5V$ , with a duty cycle of  $V_{OUT}/V_{IN}$ .

**Ground** (Pin 3)—Circuit ground.

**Feedback** (Pin 4)—Senses the regulated output voltage to complete the feedback loop. This pin is directly connected to the Output for the fixed voltage versions, but is set to 1.23V by means of a resistive divider from the output for the Adjustable version. If a feedforward capacitor is used (Adjustable version), then a negative voltage spike is generated

on this pin whenever the output is shorted. This happens because the feedforward capacitor cannot discharge fast enough, and since one end of it is dragged to Ground, the other end goes momentarily negative. To prevent the energy rating of this pin from being exceeded, a small-signal Schottky diode to Ground is recommended for DC input voltages above 40V whenever a feedforward capacitor is present (See Figure 1). Feedforward capacitor values larger than 0.1  $\mu F$  are not recommended for the same reason, whatever be the DC input voltage.

**ON /OFF** (Pin 5)—The regulator is in shutdown mode, drawing about 90  $\mu A$ , when this pin is driven to a high level ( $\geq 2.0V$ ), and is in normal operation when this Pin is left floating or driven to a low level ( $\leq 0.6V$ ). The typical value of the threshold is 1.3V and the voltage on this pin must not exceed 25V.

# Inductor Value Selection Guides

(For Continuous Mode Operation)

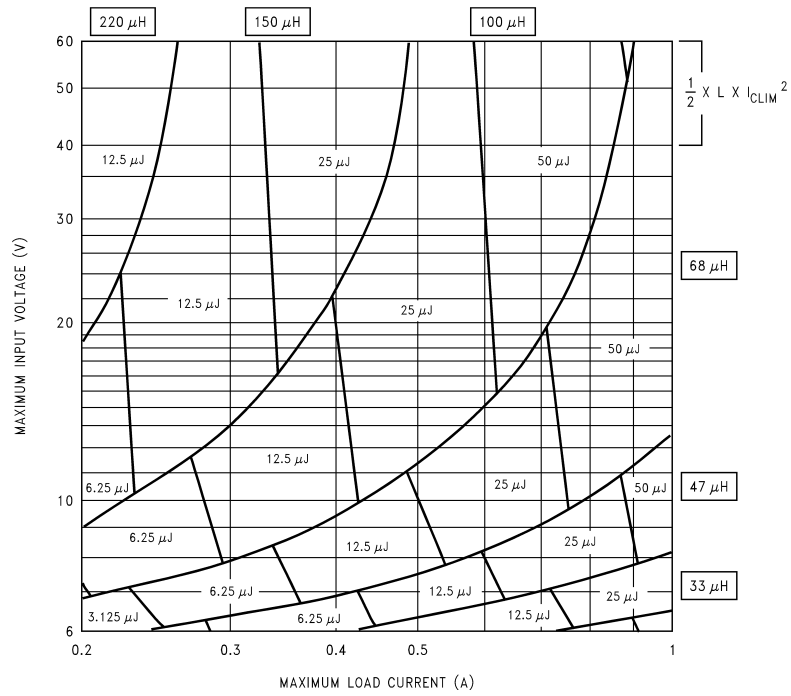

10129365

FIGURE 2. LM2591HV-3.3

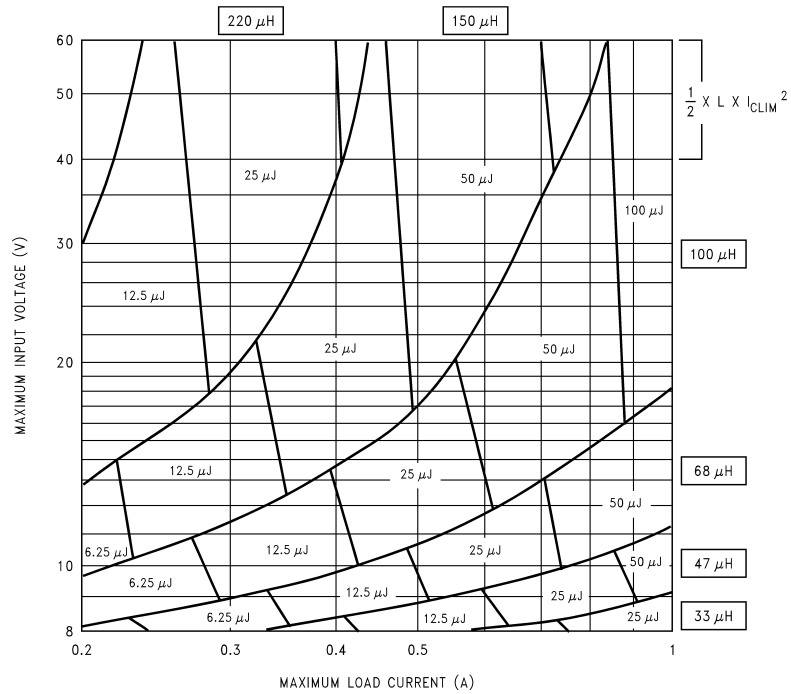

10129366

FIGURE 3. LM2591HV-5.0



## Inductor Value Selection Guides (For Continuous Mode Operation) (Continued)

<b>Coilcraft Inc.</b>	Phone	(USA): 1-800-322-2645
	Web Address	<a href="http://www.coilcraft.com">http://www.coilcraft.com</a>
<b>Coilcraft Inc., Europe</b>	Phone	(UK): 1-236-730595
	Web Address	<a href="http://www.coilcraft-europe.com">http://www.coilcraft-europe.com</a>
<b>Pulse Engineering Inc.</b>	Phone	(USA): 1-858-674-8100
	Web Address	<a href="http://www.pulseeng.com">http://www.pulseeng.com</a>
<b>Pulse Engineering Inc., Europe</b>	Phone	(UK): 1-483-401700
	Web Address	<a href="http://www.pulseeng.com">http://www.pulseeng.com</a>
<b>Renco Electronics Inc.</b>	Phone	(USA): 1-321-637-1000
	Web Address	<a href="http://www.rencousa.com">http://www.rencousa.com</a>
<b>Schott Corp.</b>	Phone	(USA): 1-952-475-1173
	Web Address	<a href="http://www.shottcorp.com">http://www.shottcorp.com</a>
<b>Cooper Electronic Tech. (Coiltronics)</b>	Phone	(USA): 1-888-414-2645
	Web Address	<a href="http://www.cooperet.com">http://www.cooperet.com</a>
<b>TDK</b>	Phone	(USA): 1-847-803-6100
	Web Address	<a href="http://www.componet.tdk.com">http://www.componet.tdk.com</a>

**FIGURE 6. Contact Information for Suggested Inductor Manufacturers**

## Application Information

### INDUCTOR SELECTION PROCEDURE

Application Note AN-1197 titled "Selecting Inductors for Buck Converters" provides detailed information on this topic. For a quick-start the designer may refer to the nomographs provided in *Figure 2* to *Figure 4*. To widen the choice of the Designer to a more general selection of available inductors, the nomographs provide the required inductance and also the energy in the core expressed in microjoules ( $\mu\text{J}$ ), as an alternative to just prescribing custom parts. The following points need to be highlighted:

1. The Energy values shown on the nomographs apply to steady operation at the corresponding x-coordinate (rated maximum load current). However under start-up, without soft-start, or a short-circuit on the output, the current in the inductor will momentarily/repetitively hit the current limit  $I_{\text{CLIM}}$  of the device, and this current could be much higher than the rated load,  $I_{\text{LOAD}}$ . This represents an overload situation, and can cause the Inductor to saturate (if it has been designed only to handle the energy of steady operation). However most types of core structures used for such applications have a large inherent air gap (for example powdered iron types or ferrite rod inductors), and so the inductance does not fall off too sharply under an overload. The device is usually able to protect itself by not allowing the current to ever exceed  $I_{\text{CLIM}}$ . But if the DC input voltage to the regulator is over 40V, the current can slew up so fast under core saturation, that the device may not be able to act fast enough to restrict the current. The current can then rise without limit till destruction of the device takes place. *Therefore to ensure reliability, it is recommended, that if the DC Input Voltage exceeds 40V, the inductor must ALWAYS be sized to handle an instantaneous current equal to  $I_{\text{CLIM}}$  without saturating, irrespective of the type of core structure/material.*
2. The Energy under steady operation is

$$e = \frac{1}{2} \times L \times I_{\text{PEAK}}^2 \mu\text{J}$$

where L is in  $\mu\text{H}$  and  $I_{\text{PEAK}}$  is the peak of the inductor current waveform with the regulator delivering  $I_{\text{LOAD}}$ . These are the energy values shown in the nomographs. See *Example 1* below.

3. The Energy under overload is

$$e_{\text{CLIM}} = \frac{1}{2} \times L \times I_{\text{CLIM}}^2 \mu\text{J}$$

If  $V_{\text{IN}} > 40\text{V}$ , the inductor should be sized to handle  $e_{\text{CLIM}}$  instead of the steady energy values. The worst case  $I_{\text{CLIM}}$  for the LM2591HV is 3A. The Energy rating depends on the Inductance. See *Example 2* below.

4. The nomographs were generated by allowing a greater amount of percentage current ripple in the Inductor as the maximum rated load decreases (see *Figure 5*). This was done to permit the use of smaller inductors at light loads. *Figure 5* however shows only the 'median' value of the current ripple. In reality there may be a great spread around this because the nomographs approximate the exact calculated inductance to standard available values. It is a good idea to refer to AN-1197 for detailed calculations if a certain maximum inductor current ripple is required for various possible reasons. Also

consider the rather wide tolerance on the nominal inductance of commercial inductors.

5. *Figure 4* shows the inductor selection curves for the Adjustable version. The y-axis is 'Et', in  $\mu\text{secs}$ . It is the applied volts across the inductor during the ON time of the switch ( $V_{\text{IN}} - V_{\text{SAT}} - V_{\text{OUT}}$ ) multiplied by the time for which the switch is on in  $\mu\text{secs}$ . See *Example 3* below.

**Example 1:** ( $V_{\text{IN}} \leq 40\text{V}$ ) LM2591HV-5.0,  $V_{\text{IN}} = 24\text{V}$ , Output 5V @ 0.8A

1. A first pass inductor selection is based upon *Inductance and rated max load current*. We choose an inductor with the Inductance value indicated by the nomograph (*Figure 3*) and a current rating equal to the maximum load current. We therefore quick-select a 100 $\mu\text{H}/0.8\text{A}$  inductor (designed for 150 kHz operation) for this application.
2. We should confirm that it is rated to handle 50  $\mu\text{J}$  (see *Figure 3*) by either estimating the peak current or by a detailed calculation as shown in AN-1197, and also that the losses are acceptable.

**Example 2:** ( $V_{\text{IN}} > 40\text{V}$ ) LM2591HV-5.0,  $V_{\text{IN}} = 48\text{V}$ , Output 5V @ 1A

1. A first pass inductor selection is based upon *Inductance and the switch current limit*. We choose an inductor with the Inductance value indicated by the nomograph (*Figure 3*) and a current rating equal to  $I_{\text{CLIM}}$ . We therefore quick-select a 100 $\mu\text{H}/3\text{A}$  inductor (designed for 150 kHz operation) for this application.
2. We should confirm that it is rated to handle  $e_{\text{CLIM}}$  by the procedure shown in AN-1197 and that the losses are acceptable. Here  $e_{\text{CLIM}}$  is:

$$e_{\text{CLIM}} = \frac{1}{2} \times 100 \times 3^2 = 450 \mu\text{J}$$

**Example 3:** ( $V_{\text{IN}} \leq 40\text{V}$ ) LM2591HV-ADJ,  $V_{\text{IN}} = 20\text{V}$ , Output 10V @ 1A

1. Since input voltage is less than 40V, a first pass inductor selection is based upon Inductance and rated max load current. We choose an inductor with the Inductance value indicated by the nomograph *Figure 4* and a current rating equal to the maximum load. But we first need to calculate Et for the given application. The Duty cycle is

$$D = \frac{V_{\text{OUT}} + V_{\text{D}}}{V_{\text{IN}} - V_{\text{SAT}} + V_{\text{D}}}$$

where  $V_{\text{D}}$  is the drop across the Catch Diode ( $\approx 0.5\text{V}$  for a Schottky) and  $V_{\text{SAT}}$  the drop across the switch ( $\approx 1.5\text{V}$ ). So

$$D = \frac{10 + 0.5}{20 - 1.5 + 0.5} = 0.55$$

And the switch ON time is

$$t_{\text{ON}} = \frac{D}{f} \times 10^6 \mu\text{s}$$

where f is the switching frequency in Hz. So

## Application Information (Continued)

$$\begin{aligned} Et &= (V_{IN} - V_{SAT} - V_{OUT}) \times t_{ON} \\ &= (20 - 1.5 - 10) \times \frac{0.55}{150000} \times 10^6 \text{ V}\mu\text{secs} \\ &= 31.3 \text{ V}\mu\text{secs} \end{aligned}$$

Therefore, looking at *Figure 2* we quick-select a 100 $\mu$ H/1A inductor (designed for 150 kHz operation) for this application.

2. We should confirm that it is rated to handle 100  $\mu$ J (see *Figure 4*) by the procedure shown in AN-1197 and that the losses are acceptable. (If the DC Input voltage had been greater than 40V we would need to consider  $e_{CLIM}$  as in Example 2 above).

Note that we have taken  $V_{SAT}$  as 1.5V which includes an estimated resistive drop across the inductor.

This completes the simplified inductor selection procedure. For more general applications and better optimization, the designer should refer to AN-1197. *Figure 6* provides helpful contact information on suggested Inductor manufacturers who may be able to recommend suitable parts, if the requirements are known.

### FEEDFORWARD CAPACITOR

(Adjustable Output Voltage Version)

$C_{FF}$  - A Feedforward Capacitor  $C_{FF}$ , shown across R2 in *Figure 1* is used when the output voltage is greater than 10V or when  $C_{OUT}$  has a very low ESR. This capacitor adds lead compensation to the feedback loop and increases the phase margin for better loop stability.

If the output voltage ripple is large (> 5% of the nominal output voltage), this ripple can be coupled to the feedback pin through the feedforward capacitor and cause the error comparator to trigger the error flag. In this situation, adding a resistor,  $R_{FF}$ , in series with the feedforward capacitor, approximately 3 times  $R_1$ , will attenuate the ripple voltage at the feedback pin.

### INPUT CAPACITOR

$C_{IN}$  — A low ESR aluminum or tantalum bypass capacitor is needed between the input pin and ground pin. It must be located near the regulator using short leads. This capacitor prevents large voltage transients from appearing at the input, and provides the instantaneous current needed each time the switch turns on.

The important parameters for the Input capacitor are the voltage rating and the RMS current rating. Because of the relatively high RMS currents flowing in a buck regulator's input capacitor, this capacitor should be chosen for its RMS current rating rather than its capacitance or voltage ratings, although the capacitance value and voltage rating are directly related to the RMS current rating. The voltage rating of the capacitor and its RMS ripple current capability must never be exceeded.

### OUTPUT CAPACITOR

$C_{OUT}$  — An output capacitor is required to filter the output and provide regulator loop stability. Low impedance or low ESR Electrolytic or solid tantalum capacitors designed for switching regulator applications must be used. When selecting an output capacitor, the important capacitor parameters are; the 100 kHz Equivalent Series Resistance (ESR), the RMS ripple current rating, voltage rating, and capacitance value. For the output capacitor, the ESR value is the most important parameter. The ESR should generally not be less than 100 m $\Omega$  or there will be loop instability. If the ESR is too large, efficiency and output voltage ripple are effected. So ESR must be chosen carefully.

### CATCH DIODE

Buck regulators require a diode to provide a return path for the inductor current when the switch turns off. This must be a fast diode and must be located close to the LM2591HV using short leads and short printed circuit traces.

Because of their very fast switching speed and low forward voltage drop, Schottky diodes provide the best performance, especially in low output voltage applications (5V and lower). Ultra-fast recovery, or High-Efficiency rectifiers are also a good choice, but some types with an abrupt turnoff characteristic may cause instability or EMI problems. Ultra-fast recovery diodes typically have reverse recovery times of 50 ns or less. The diode must be chosen for its average/RMS current rating and maximum voltage rating. The voltage rating of the diode must be greater than the DC input voltage (not the output voltage).

### DELAYED STARTUP

The circuit in *Figure 7* uses the the  $\overline{ON}/OFF$  pin to provide a time delay between the time the input voltage is applied and the time the output voltage comes up (only the circuitry pertaining to the delayed start up is shown). As the input voltage rises, the charging of capacitor C1 pulls the  $\overline{ON}/OFF$  pin high, keeping the regulator off. Once the input voltage reaches its final value and the capacitor stops charging, and resistor  $R_2$  pulls the  $\overline{ON}/OFF$  pin low, thus allowing the circuit to start switching. Resistor  $R_1$  is included to limit the maximum voltage applied to the  $\overline{ON}/OFF$  pin (maximum of 25V), reduces power supply noise sensitivity, and also limits the capacitor, C1, discharge current. When high input ripple voltage exists, avoid long delay time, because this ripple can be coupled into the  $\overline{ON}/OFF$  pin and cause problems.

This delayed startup feature is useful in situations where the input power source is limited in the amount of current it can deliver. It allows the input voltage to rise to a higher voltage before the regulator starts operating. Buck regulators require less input current at higher input voltages.

## Application Information (Continued)

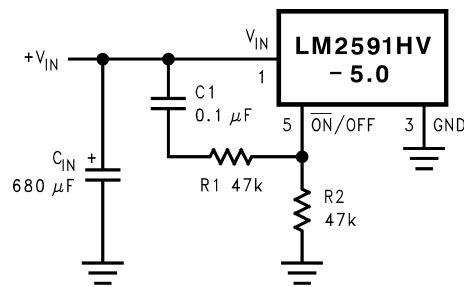

10129336

FIGURE 7. Delayed Startup

### UNDERVOLTAGE LOCKOUT

Some applications require the regulator to remain off until the input voltage reaches a predetermined voltage. An undervoltage lockout feature applied to a buck regulator is shown in *Figure 8*, while *Figure 9* and *Figure 10* applies the same feature to an inverting circuit. The circuit in *Figure 9* features a constant threshold voltage for turn on and turn off (zener voltage plus approximately one volt). If hysteresis is

needed, the circuit in *Figure 10* has a turn ON voltage which is different than the turn OFF voltage. The amount of hysteresis is approximately equal to the value of the output voltage. If zener voltages greater than 25V are used, an additional 47 kΩ resistor is needed from the  $\overline{\text{ON}}/\text{OFF}$  pin to the ground pin to stay within the 25V maximum limit of the  $\overline{\text{ON}}/\text{OFF}$  pin.

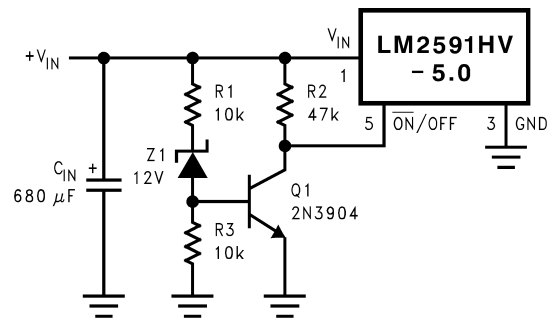

10129337

FIGURE 8. Undervoltage Lockout for Buck Regulator

## Application Information (Continued)

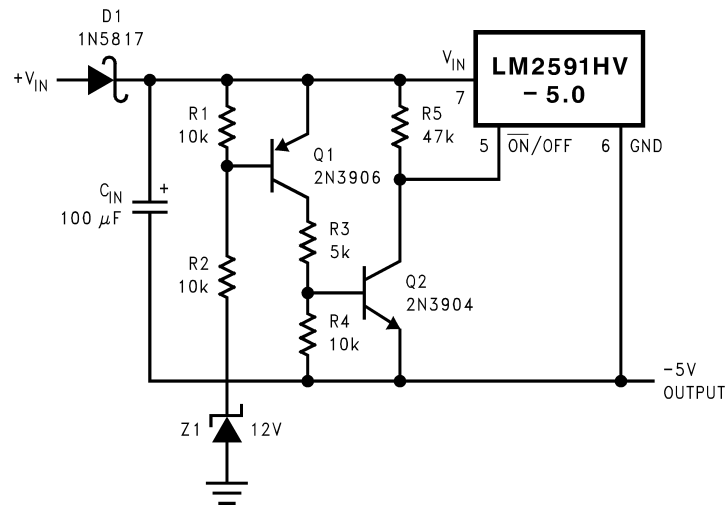

10129384

This circuit has an ON/OFF threshold of approximately 13V.

**FIGURE 9. Undervoltage Lockout for Inverting Regulator**

### INVERTING REGULATOR

The circuit in *Figure 11* converts a positive input voltage to a negative output voltage with a common ground. The circuit operates by bootstrapping the regulator's ground pin to the negative output voltage, then grounding the feedback pin, the regulator senses the inverted output voltage and regulates it.

This example uses the LM2591HV-5.0 to generate a -5V output, but other output voltages are possible by selecting other output voltage versions, including the adjustable version. Since this regulator topology can produce an output voltage that is either greater than or less than the input voltage, the maximum output current greatly depends on both the input and output voltage.

To determine how much load current is possible before the internal device current limit is reached (and power limiting occurs), the system must be evaluated as a buck-boost configuration rather than as a buck. The peak switch current in Amperes, for such a configuration is given as:

$$I_{PEAK} = I_{LOAD} \times \left( \frac{V_{IN} + V_{OUT}}{V_{IN}} \right) + \frac{V_{IN} \times V_{OUT} \times 10^6}{2 \times L \times f \times (V_{IN} + V_{OUT})}$$

where L is in µH and f is in Hz. The maximum possible load current  $I_{LOAD}$  is limited by the requirement that  $I_{PEAK} \leq I_{CLIM}$ . While checking for this, take  $I_{CLIM}$  to be the lowest possible current limit value (min across tolerance and temperature is 1.2A for the LM2591HV). Also to account for inductor toler-

ances, we should take the min value of Inductance for L in the equation above (typically 20% less than the nominal value). Further, the above equation disregards the drop across the Switch and the diode. This is equivalent to assuming 100% efficiency, which is never so. Therefore expect  $I_{PEAK}$  to be an additional 10-20% higher than calculated from the above equation.

The reader is also referred to Application Note AN-1157 for examples based on positive to negative configuration.

The maximum voltage appearing across the regulator is the absolute sum of the input and output voltage, and this must be limited to a maximum of 60V. For example, when converting +20V to -12V, the regulator would see 32V between the input pin and ground pin. The LM2591HV has a maximum input voltage spec of 60V.

Additional diodes are required in this regulator configuration. Diode D1 is used to isolate input voltage ripple or noise from coupling through the  $C_{IN}$  capacitor to the output, under light or no load conditions. Also, this diode isolation changes the topology to closely resemble a buck configuration thus providing good closed loop stability. A Schottky diode is recommended for low input voltages, (because of its lower voltage drop) but for higher input voltages, a fast recovery diode could be used.

Without diode D3, when the input voltage is first applied, the charging current of  $C_{IN}$  can pull the output positive by several volts for a short period of time. Adding D3 prevents the output from going positive by more than a diode voltage.



## Application Information (Continued)

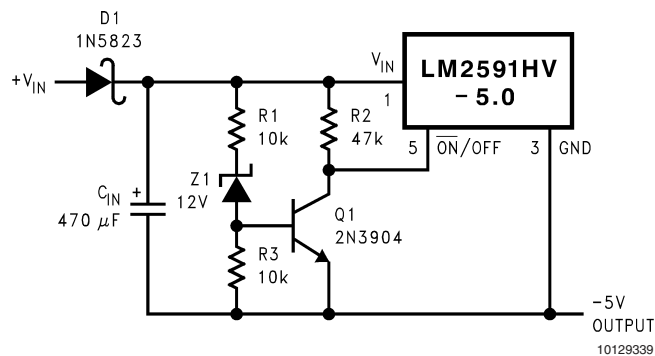

This circuit has hysteresis

Regulator starts switching at  $V_{IN} = 13V$

Regulator stops switching at  $V_{IN} = 8V$

**FIGURE 10. Undervoltage Lockout with Hysteresis for Inverting Regulator**

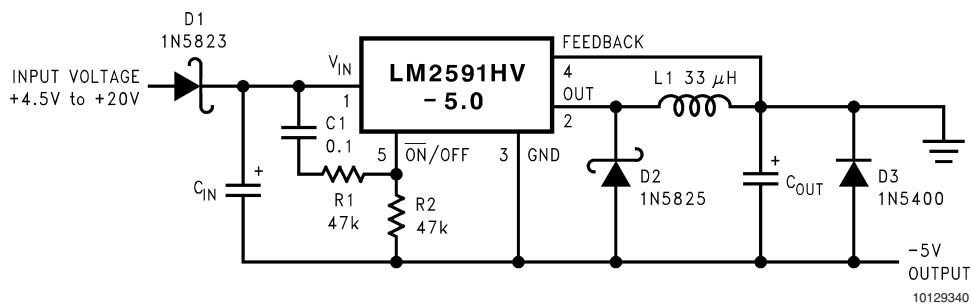

$C_{IN}$  — 68  $\mu F$ /25V Tant. Sprague 595D

470  $\mu F$ /50V Elec. Panasonic HFQ

$C_{OUT}$  — 47  $\mu F$ /20V Tant. Sprague 595D

220  $\mu F$ /25V Elec. Panasonic HFQ

**FIGURE 11. Inverting -5V Regulator with Delayed Startup**

Because of differences in the operation of the inverting regulator, the standard design procedure is not used to select the inductor value. In the majority of designs, a 33  $\mu H$ , 3A inductor is the best choice. Capacitor selection can also be narrowed down to just a few values.

This type of inverting regulator can require relatively large amounts of input current when starting up, even with light loads. Input currents as high as the LM2591HV current limit (approx 4A) are needed for at least 2 ms or more, until the output reaches its nominal output voltage. The actual time depends on the output voltage and the size of the output capacitor. Input power sources that are current limited or sources that can not deliver these currents without getting loaded down, may not work correctly. Because of the relatively high startup currents required by the inverting topology, the delayed startup feature ( $C_1$ ,  $R_1$  and  $R_2$ ) shown in *Figure*

11 is recommended. By delaying the regulator startup, the input capacitor is allowed to charge up to a higher voltage before the switcher begins operating. A portion of the high input current needed for startup is now supplied by the input capacitor ( $C_{IN}$ ). For severe start up conditions, the input capacitor can be made much larger than normal.

### INVERTING REGULATOR SHUTDOWN METHODS

To use the  $\overline{ON}/OFF$  pin in a standard buck configuration is simple, pull it below 1.3V (@25°C, referenced to ground) to turn regulator ON, pull it above 1.3V to shut the regulator OFF. With the inverting configuration, some level shifting is required, because the ground pin of the regulator is no longer at ground, but is now setting at the negative output voltage level. Two different shutdown methods for inverting regulators are shown in *Figure 12* and *Figure 13*

## Application Information (Continued)

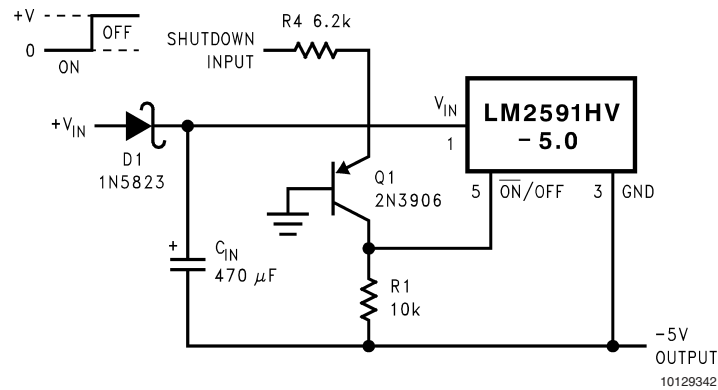

FIGURE 12. Inverting Regulator Ground Referenced Shutdown

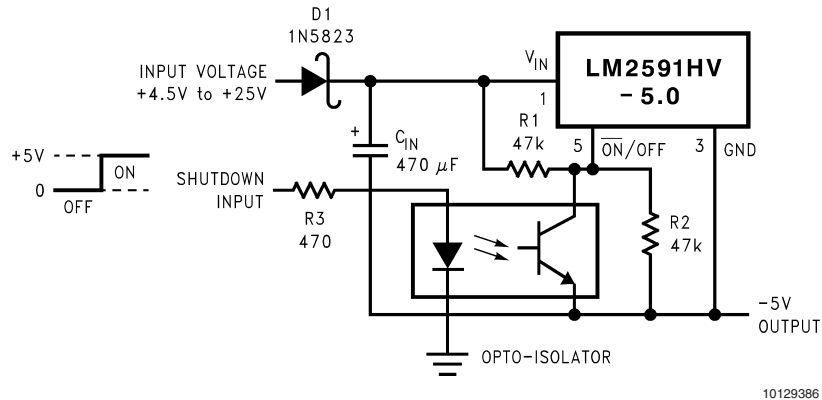

FIGURE 13. Inverting Regulator Ground Referenced Shutdown using Opto Device

### LAYOUT SUGGESTIONS

As in any switching regulator, layout is very important. Rapidly switching currents associated with wiring inductance can generate voltage transients which can cause problems. For minimal inductance and ground loops, with reference to *Figure 1*, the wires indicated by **heavy lines should be wide printed circuit traces and should be kept as short as possible**. For best results, external components should be located as close to the switcher IC as possible using ground plane construction or single point grounding.

If **open core inductors are used**, special care must be taken as to the location and positioning of this type of inductor. Allowing the inductor flux to intersect sensitive feedback, IC groundpath and  $C_{OUT}$  wiring can cause problems.

When using the adjustable version, special care must be taken as to the location of the feedback resistors and the associated wiring. Physically locate both resistors near the IC, and route the wiring away from the inductor, especially an open core type of inductor.

**Physical Dimensions** inches (millimeters)  
 unless otherwise noted

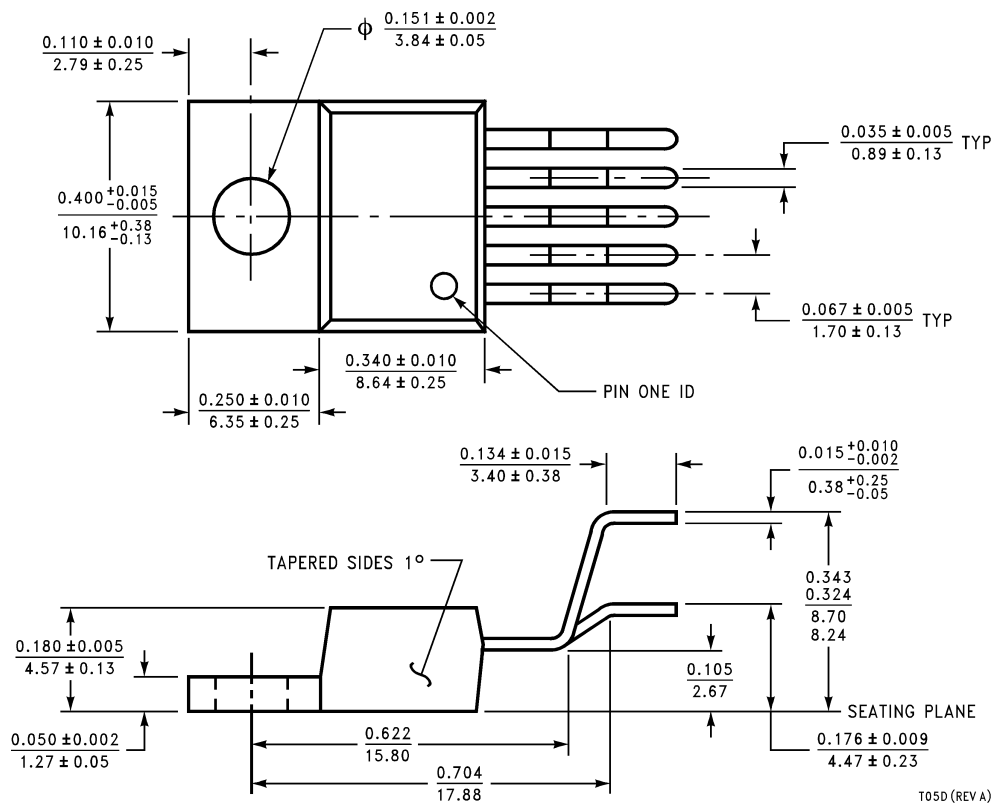

**5-Lead TO-220 Bent and Staggered Package**  
**Order Number LM2591HVT-3.3, LM2591HVT-5.0**  
**or LM2591HVT-ADJ**  
**NS Package Number T05D**

T05D (REV A)

**Physical Dimensions** inches (millimeters) unless otherwise noted (Continued)

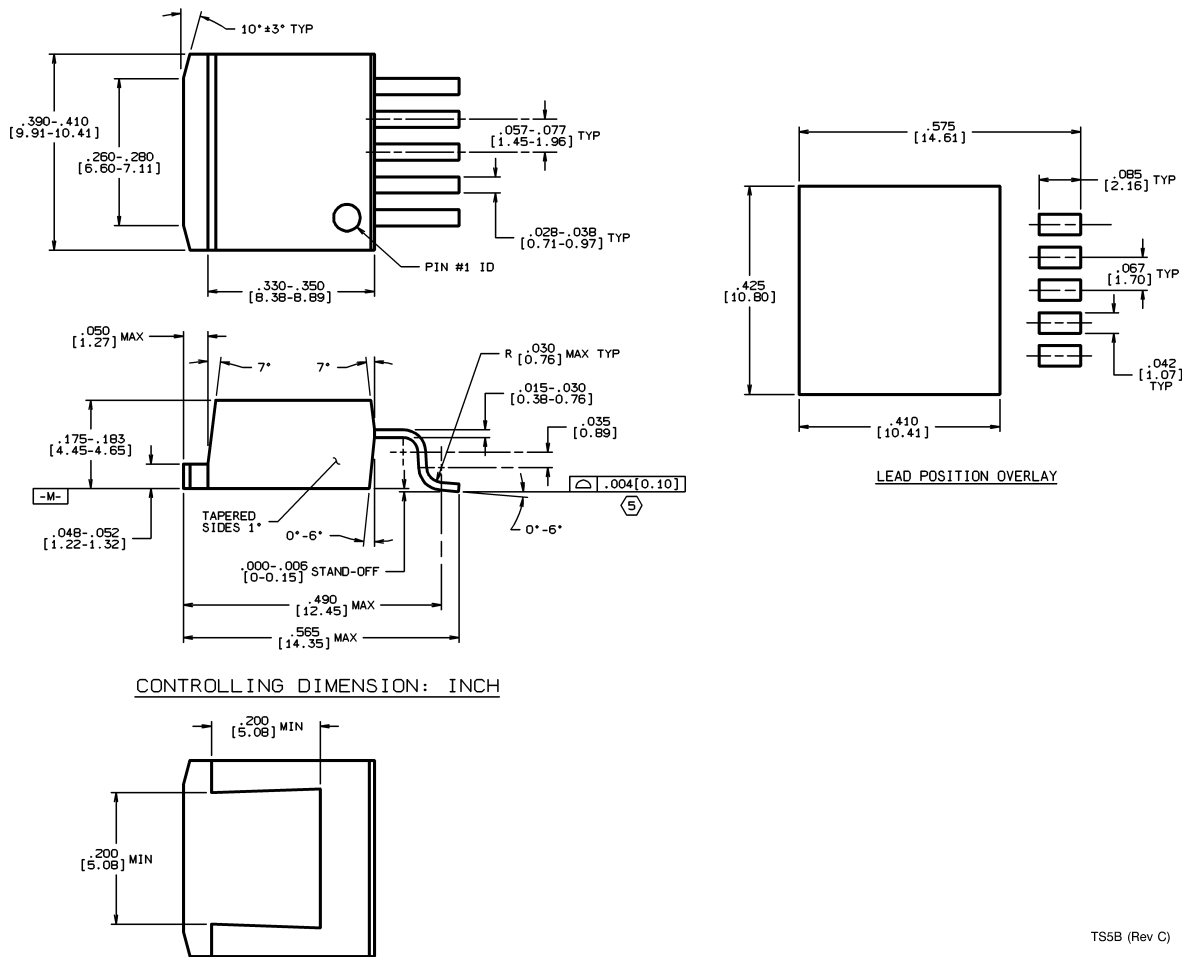

**5-Lead TO-263 Bent and Formed Package**  
**Order Number LM2591HVS-3.3, LM2591HVS-5.0 or LM2591HVS-ADJ**  
**NS Package Number TS5B**

TS5B (Rev C)

**LIFE SUPPORT POLICY**

NATIONAL'S PRODUCTS ARE NOT AUTHORIZED FOR USE AS CRITICAL COMPONENTS IN LIFE SUPPORT DEVICES OR SYSTEMS WITHOUT THE EXPRESS WRITTEN APPROVAL OF THE PRESIDENT AND GENERAL COUNSEL OF NATIONAL SEMICONDUCTOR CORPORATION. As used herein:

1. Life support devices or systems are devices or systems which, (a) are intended for surgical implant into the body, or (b) support or sustain life, and whose failure to perform when properly used in accordance with instructions for use provided in the labeling, can be reasonably expected to result in a significant injury to the user.
2. A critical component is any component of a life support device or system whose failure to perform can be reasonably expected to cause the failure of the life support device or system, or to affect its safety or effectiveness.



**National Semiconductor**  
**Americas Customer**  
**Support Center**  
 Email: new.feedback@nsc.com  
 Tel: 1-800-272-9959

**National Semiconductor**  
**Europe Customer Support Center**  
 Fax: +49 (0) 180-530 85 86  
 Email: europe.support@nsc.com  
 Deutsch Tel: +49 (0) 69 9508 6208  
 English Tel: +44 (0) 870 24 0 2171  
 Français Tel: +33 (0) 1 41 91 8790

**National Semiconductor**  
**Asia Pacific Customer**  
**Support Center**  
 Email: ap.support@nsc.com

**National Semiconductor**  
**Japan Customer Support Center**  
 Fax: 81-3-5639-7507  
 Email: jpn.feedback@nsc.com  
 Tel: 81-3-5639-7560

www.national.com