



## PI6C48535-01

### 3.3V Low Skew 1-to-4 LVTTL/LVCMOS to LVPECL Fanout Buffer

#### Features

- Maximum operation frequency: 500 MHz
- 4 pair of differential LVPECL outputs
- Selectable CLK<sub>0</sub> and CLK<sub>1</sub> inputs
- CLK<sub>0</sub>, CLK<sub>1</sub> accept LVCMOS, LVTTL input level
- Output Skew: 80ps (maximum)
- Part-to-part skew: 150ps (maximum)
- Propagation delay: 1.9ns (maximum)
- 3.3V power supply
- Pin-to-pin compatible to ICS8535-01
- Operating Temperature: -40°C to 85°C
- Packaging (Pb-free & Green available):  
— 20-pin TSSOP (L)

#### Description

The PI6C48535-01 is a high-performance low-skew LVPECL fanout buffer. PI6C48535-01 features two selectable single-ended clock inputs and translates to four LVPECL outputs. The CLK<sub>0</sub> and CLK<sub>1</sub> inputs accept LVCMOS or LVTTL signals. The outputs are synchronized with input clock during asynchronous assertion/deassertion of CLK\_EN pin. PI6C48535-01 is ideal for single-ended LVTTL/LVCMOS to LVPECL translations. Typical clock translation and distribution applications are data-communications and telecommunications.

#### Block Diagram

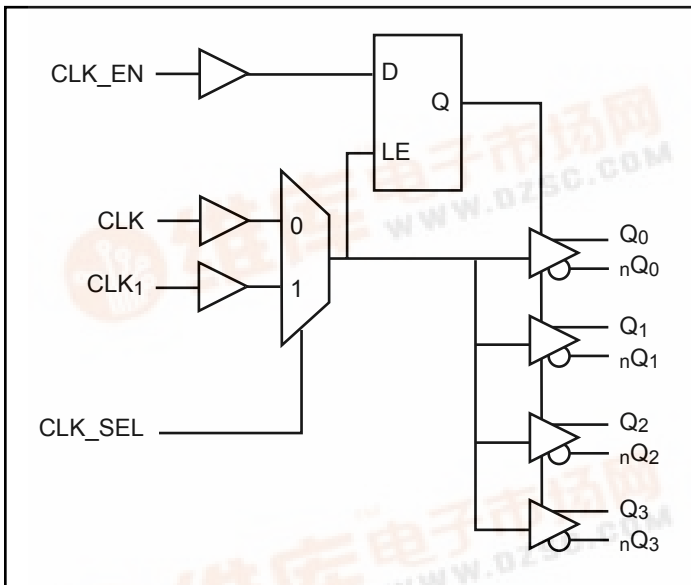

#### Pin Configuration

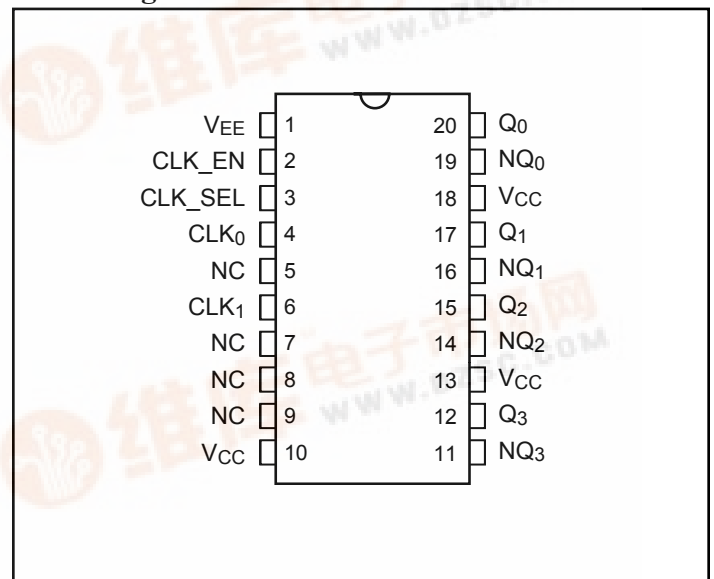



### Pin Description

Name	Pin #	Type	Description
V <sub>EE</sub>	1	P	Connect to Negative power supply
CLK_EN	2	I_PU	Synchronizing clock enable. When high, clock outputs follow clock input. When low, Qx outputs are forced low, nQx outputs are forced high. LVCMOS/LVTTL level with 50KΩ pull up.
CLK_SEL	3	I_PD	Clock select input. When high, selects CLK <sub>1</sub> input. When low, selects CLK <sub>0</sub> input. LVCMOS/LVTTL level with 50KΩ pull down.
CLK <sub>0</sub>	4	I_PD	LVCMOS / LVTTL clock input
CLK <sub>1</sub>	6	I_PD	LVCMOS / LVTTL clock input
NC	5, 7, 8, 9		No internal connection.
V <sub>CC</sub>	10, 13, 18	P	Connect to 3.3V.
Q <sub>3</sub> , nQ <sub>3</sub>	11, 12	O	Differential output pair, LVPECL interface level.
Q <sub>2</sub> , nQ <sub>2</sub>	14, 15	O	Differential output pair, LVPECL interface level.
Q <sub>1</sub> , nQ <sub>1</sub>	16, 17	O	Differential output pair, LVPECL interface level.
Q <sub>0</sub> , nQ <sub>0</sub>	19, 20	O	Differential output pair, LVPECL interface level.

**Notes:**

- I = Input, O = Output, P = Power supply connection, I\_PD = Input with pull down, I\_PU = Input with pull up.

### Pin Characteristics

Symbol	Parameter	Conditions	Min.	Typ.	Max.	Units
C <sub>IN</sub>	Input Capacitance				4	pF
R <sub>pullup</sub>	Input Pullup Resistance			50		KΩ
R <sub>pulldown</sub>	Input Pulldown Resistance			50		

### Control Input Function Table

Inputs			Outputs	
CLK_EN	CLK_SEL	Selected Source	Q <sub>0</sub> :Q <sub>3</sub>	nQ <sub>0</sub> :nQ <sub>3</sub>
0	0	CLK <sub>0</sub>	Disabled: Low	Disabled: High
0	1	CLK <sub>1</sub>	Disabled: Low	Disabled: High
1	0	CLK <sub>0</sub>	Enabled	Enabled
1	1	CLK <sub>1</sub>	Enabled	Enabled

**Notes:**

- After CLK\_EN switches, the clock outputs are disabled or enabled following a rising and falling input clock edge as show below.

**Figure 1. CLK\_EN Timing Diagram**

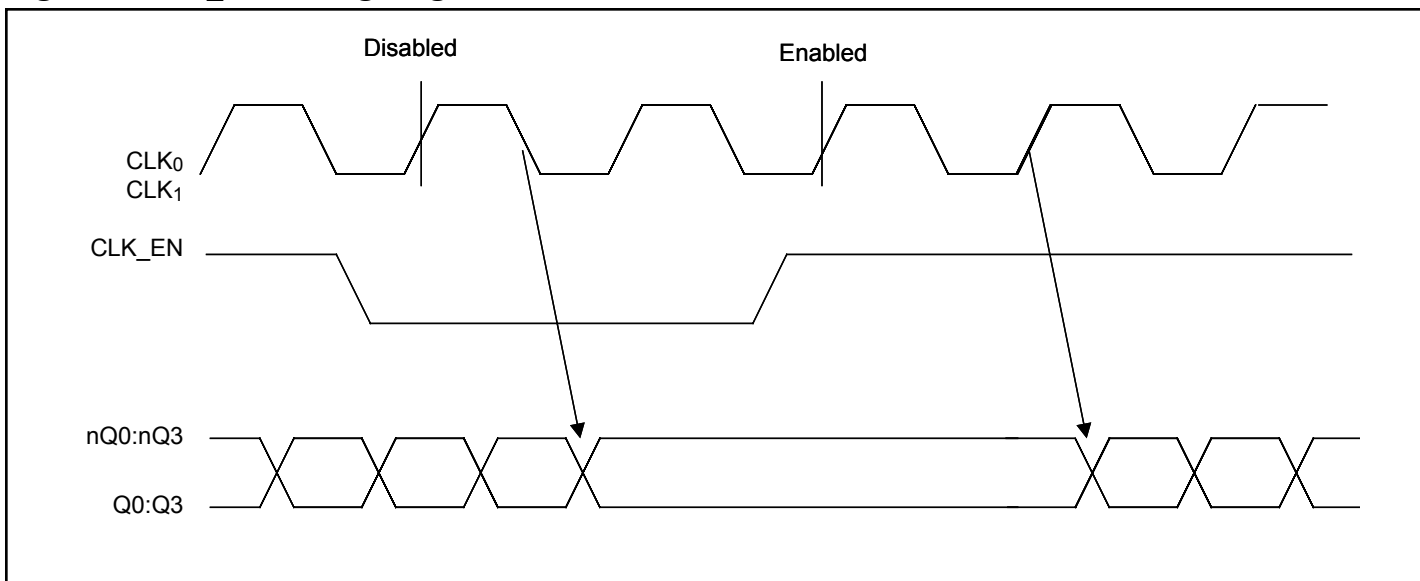

**Clock Input Function Table**

Inputs	Outputs	
CLK <sub>0</sub> or CLK <sub>1</sub>	Q <sub>0</sub> :Q <sub>3</sub>	nQ <sub>0</sub> :nQ <sub>3</sub>
0	LOW	HIGH
1	HIGH	LOW

**Absolute Maximum Ratings**

Symbol	Parameter	Conditions	Min.	Typ.	Max.	Units
V <sub>CC</sub>	Supply voltage	Referenced to GND			4.6	V
V <sub>IN</sub>	Input voltage	Referenced to GND	-0.5		V <sub>CC</sub> +0.5V	
V <sub>OUT</sub>	Output voltage	Referenced to GND	-0.5		V <sub>CC</sub> +0.5V	
T <sub>STG</sub>	Storage temperature		-65		150	°C

**Notes:**

- Stresses above those listed under Absolute Maximum Ratings may cause permanent damage to the device. These ratings are stress specifications only and correct functional operation of the device at these or any other conditions above those listed in the operational sections of the specifications is not implied. Exposure to absolute maximum rating conditions for extended periods may affect product reliability.

**Operating Conditions**

Symbol	Parameter	Conditions	Min.	Typ.	Max.	Units
V <sub>CC</sub>	Power Supply Voltage		3.0	3.3	3.6	V
T <sub>A</sub>	Ambient Temperature		-40		85	°C
I <sub>EE</sub>	Power Supply Current	500 MHz			60	mA



**LVCMOS/LVTTL DC Characteristics** ( $T_A = -40^{\circ}\text{C}$  to  $85^{\circ}\text{C}$ ,  $V_{CC} = 3.0\text{V}$  to  $3.6\text{V}$  unless otherwise stated below.)

Symbol	Parameter		Conditions	Min.	Typ.	Max.	Units
$V_{IH}$	Input High Voltage	CLK <sub>0</sub> , CLK <sub>1</sub> , CLK_EN, CLK_SEL		2		$V_{CC}+0.3$	V
$V_{IL}$	Input Low Voltage	CLK <sub>0</sub> , CLK <sub>1</sub>		-0.3		1.3	V
		CLK_EN, CLK_SEL		-0.3		0.8	V
$I_{IH}$	Input High Current	CLK <sub>0</sub> , CLK <sub>1</sub> , CLK_SEL	$V_{IN} = V_{CC} = 3.6\text{V}$			150	uA
		CLK_EN	$V_{IN} = V_{CC} = 3.6\text{V}$			5	uA
$I_{IL}$	Input Low Current	CLK <sub>0</sub> , CLK <sub>1</sub> , CLK_SEL	$V_{IN} = 0\text{V}$ , $V_{CC} = 3.6\text{V}$	-5			uA
		CLK_EN	$V_{IN} = 0\text{V}$ , $V_{CC} = 3.6\text{V}$	-150			uA

**LVPECL DC Characteristics** ( $T_A = -40^{\circ}\text{C}$  to  $85^{\circ}\text{C}$ ,  $V_{CC} = 3.0\text{V}$  to  $3.6\text{V}$  unless otherwise stated below.)

Symbol	Parameter	Conditions	Min.	Typ.	Max.	Units
$V_{OH}$	Output High Voltage <sup>(1)</sup>		$V_{CC}-1.4$		$V_{CC}-0.9$	V
$V_{OL}$	Output Low Voltage <sup>(1)</sup>		$V_{CC}-2.0$		$V_{CC}-1.7$	
$V_{SWING}$	Peak-to-peak Output Voltage Swing		0.6		1.0	

**Notes:**

1. Outputs terminated with  $50\Omega$  to  $V_{CC}-2.0\text{V}$

**AC Characteristics** ( $T_A = -40^{\circ}\text{C}$  to  $85^{\circ}\text{C}$ ,  $V_{CC} = 3.0\text{V}$  to  $3.6\text{V}$ )

Symbol	Parameter	Conditions	Min.	Typ.	Max.	Units
$f_{max}$	Output Frequency				500	MHz
$t_{pd}$	Propagation Delay <sup>(1)</sup>		1.0		1.9	ns
$T_{sk(o)}$	Output-to-output Skew <sup>(2)</sup>				80	ps
$T_{sk(pp)}$	Part-to-part Skew <sup>(3)</sup>				150	
$t_r/t_f$	Output Rise/Fall time	20% - 80%	80		400	
odc	Output Duty Cycle		40		60	%

**Notes:**

1. Measured from the  $V_{CC}/2$  of the input to the differential output crossing point
2. Defined as skew between outputs at the same supply voltage and with equal load condition. Measured at the outputs differential crossing point.
3. Defined as skew between outputs on different parts operating at the same supply voltage and with equal load condition. Measured at the outputs differential crossing point.
4. All parameters are measured at 500 MHz unless noted otherwise

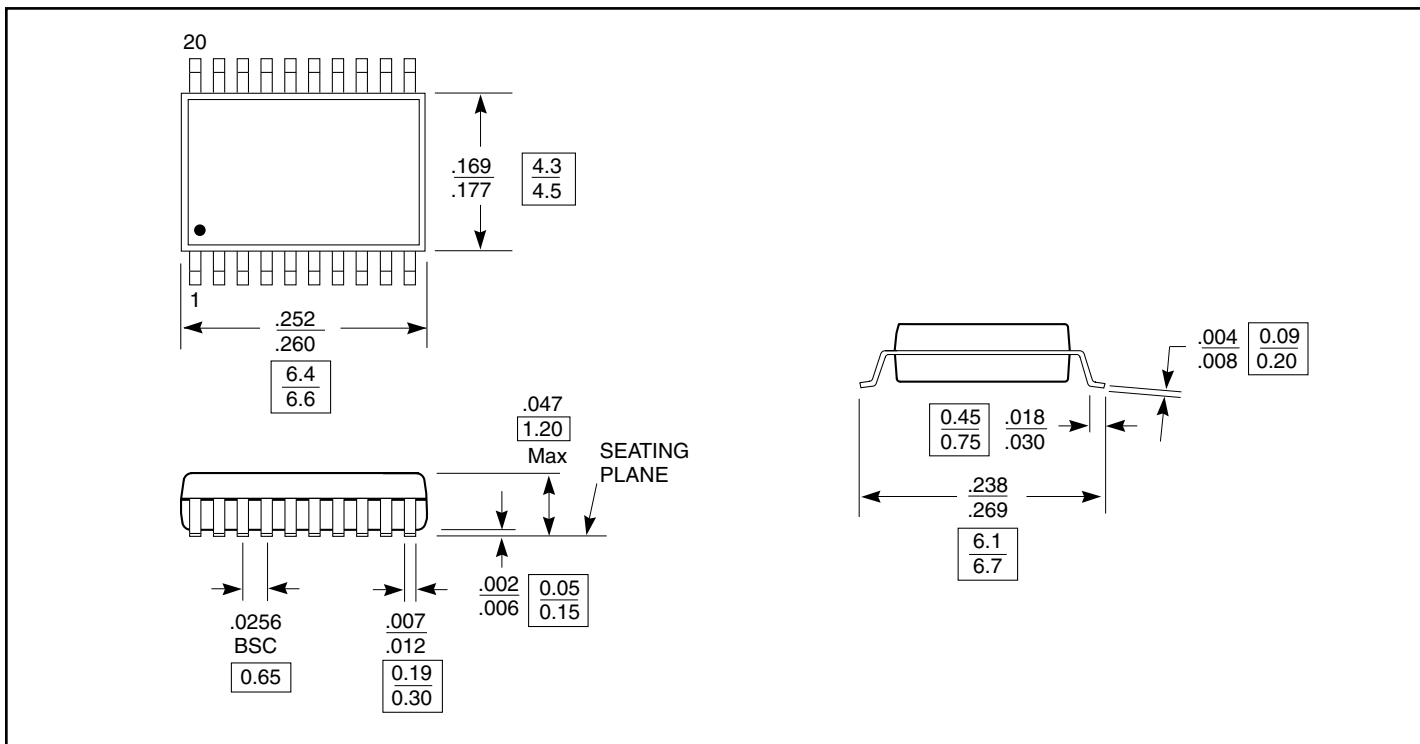
**Packaging Mechanical: 20-Pin TSSOP (L)**

**Ordering Information**

Ordering Code	Package Code	Package Description
PI6C48535-01L	L	20-pin 173-mil wide TSSOP
PI6C48535-01LE	L	Pb-free & Green 20-pin 173-mil wide TSSOP

**Notes:**

- Thermal characteristics can be found on the company web site at [www.pericom.com/packaging/](http://www.pericom.com/packaging/)
- E = Pb-free & Green
- X suffix = Tape/Reel