

[查询PI7C7100供应商](#)

[捷多邦，专业PCB打样工厂，24小时加急出货](#)

PI7C7100 3-Port PCI Bridge

Rev 1.1



Pericom Semiconductor Corporation

The Complete Interface Solution

2380 Bering Drive, San Jose, California 95131

Telephone: 1-877-PERICOM, (1-877-737-4266)

Fax: (408) 435-1100, E-mail: nolimits@pericom.com

Internet: <http://www.pericom.com>

© 2000 Pericom Semiconductor Corporation





LIFESUPPORTPOLICY

Pericom Semiconductor Corporation's products are not authorized for use as critical components in life support devices or systems unless a specific written agreement pertaining to such intended use is executed between the manufacturer and an officer of PSC.

1. Life support devices or systems are devices or systems which:
 - a) are intended for surgical implant into the body or
 - b) support or sustain life and whose failure to perform, when properly used in accordance with instructions for use provided in the labeling, can be reasonably expected to result in a significant injury to the user.
2. A critical component is any component of a life support device or system whose failure to perform can be reasonably expected to cause the failure of the life support device or system, or to affect its safety or effectiveness. Pericom Semiconductor Corporation reserves the right to make changes to its products or specifications at any time, without notice, in order to improve design or performance and to supply the best possible product. Pericom Semiconductor does not assume any responsibility for use of any circuitry described other than the circuitry embodied in a Pericom Semiconductor product. The Company makes no representations that circuitry described herein is free from patent infringement or other rights of third parties which may result from its use. No license is granted by implication or otherwise under any patent, patent rights or other rights, of Pericom Semiconductor Corporation.

All other trademarks are of their respective companies.



Table of Contents

- 1. **Introduction/Product Features** 1
- 2. **PI7C7100 Block Diagram** 3
- 3. **Signal Definitions** 4
 - 3.1 Signal Types 4
 - 3.2 Signals 4
 - 3.2.1 Primary Bus Interface Signals 4
 - 3.2.2 Secondary Bus Interface Signals 6
 - 3.2.3 Clock Signals 8
 - 3.2.4 Miscellaneous Signals 8
 - 3.2.5 JTAG Boundary Scan Signals 9
 - 3.2.6 Power and Ground 9
 - 3.3 PI7C7100 PBGA Pin Listing 9
- 4. **PCIBus Operation** 13
 - 4.1 Types of Transactions 13
 - 4.2 Single Address Phase 14
 - 4.3 Device Select (DEVSEL#) Generation 14
 - 4.4 Data Phase 14
 - 4.5 Write Transactions 14
 - 4.5.1 Posted Write Transactions 14
 - 4.5.2 Memory Write and Invalidate Transactions 15
 - 4.5.3 Delayed Write Transactions 15
 - 4.5.4 Write Transaction Address Boundaries 16
 - 4.5.5 Buffering Multiple Write Transactions 16
 - 4.5.6 Fast Back-to-Back Write Transactions 16
 - 4.6 Read Transactions 17
 - 4.6.1 Prefetchable Read Transactions 17
 - 4.6.2 Non-prefetchable Read Transactions 17
 - 4.6.3 Read Pre-fetch Address Boundaries 17
 - 4.6.4 Delayed Read Requests 18
 - 4.6.5 Delayed Read Completion with Target 18
 - 4.6.6 Delayed Read Completion on Initiator Bus 18
 - 4.7 Configuration Transactions 19
 - 4.7.1 Type 0 Access to PI7C7100 19
 - 4.7.2 Type 1 to Type 0 Conversion 20
 - 4.7.3 Type 1 to Type 1 Forwarding 21
 - 4.7.4 Special Cycles 22
 - 4.8 Transaction Termination 22
 - 4.8.1 Master Termination Initiated by PI7C7100 23
 - 4.8.2 Master Abort Received by PI7C7100 23
 - 4.8.3 Target Termination Received by PI7C7100 24
 - 4.8.3.1 Delayed Write Target Termination Response 24
 - 4.8.3.2 Posted Write Target Termination Response 24
 - 4.8.3.3 Delayed Read Target Termination Response 25
 - 4.8.4 Target Termination Initiated by PI7C7100 26
 - 4.8.4.1 Target Retry 26
 - 4.8.4.2 Target Disconnect 27



4.8.4.3 Target Abort 27

4.9 Concurrent Mode Operation 27

5. Address Decoding 28

5.1 Address Ranges 28

5.2 I/O Address Decoding 28

5.2.1 I/O Base and Limit Address Registers 28

5.2.2 ISA Mode 29

5.3 Memory Address Decoding 29

5.3.1 Memory-Mapped I/O Base and Limit Address Registers 30

5.3.2 Prefetchable Memory Base and Limit Address Registers 30

5.4 VGA Support 31

5.4.1 VGA Mode 31

5.4.2 VGA Snoop Mode 31

6. Transaction Ordering 32

6.1 Transactions Governed by Ordering Rules 32

6.2 General Ordering Guidelines 32

6.3 Ordering Rules 33

6.4 Data Synchronization 34

7. Error Handling 35

7.1 Address Parity Errors 35

7.2 Data Parity Errors 35

7.2.1 Configuration Write Transactions to Configuration Space 35

7.2.2 Read Transactions 36

7.2.3 Delayed Write Transactions 36

7.2.4 Posted Write Transactions 38

7.3 Data Parity Error Reporting Summary 39

7.4 System Error (SERR#) Reporting 45

8. Exclusive Access 46

8.1 Concurrent Locks 46

8.2 Acquiring Exclusive Access across PI7C7100 46

8.3 Ending Exclusive Access 47

9. PCI Bus Arbitration 48

9.1 Primary PCI Bus Arbitration 48

9.2 Secondary PCI Bus Arbitration 48

9.2.1 Secondary Bus Arbitration Using the Internal Arbiter 48

9.2.2 Secondary Bus Arbitration Using an External Arbiter 49

9.2.3 Bus Parking 49

10. Clocks 50

10.1 Primary Clock Inputs 50

10.2 Secondary Clock Outputs 50

11. Reset 51

11.1 Primary Interface Reset 51

11.2 Secondary Interface Reset 51

11.3 Chip Reset 51

12. Supported Commands 52

12.1 Primary Interface 52

12.2 Secondary Interface 54

13. Configuration Registers 55



.....

13.1	Config Register 1	55
13.2	Config Register 2	56
13.2.1	Config Register 1 or 2: Vendor ID Register (read only, bit 15-0; offset 00h)	57
13.2.2	Config Register 1: Device ID Register (read only, bit 31-16; offset 00h)	57
13.2.3	Config Register 2: Device ID Register (read only, bit 31-16; offset 00h)	57
13.2.4	Config Register 1: Command Register (bit 15-0; offset 04h)	57
13.2.5	Config Register 2: Command Register (bit 15-0; offset 04h)	58
13.2.6	Config Register 1 or 2: Status Register (for primary bus, bit 31-16; offset 04h)	59
13.2.7	Config Register 1 or 2: Revision ID Register (read only, bit 7-0; offset 08h)	60
13.2.8	Config Register 1 or 2: Class Code Register (read only, bit 31-8; offset 08h)	60
13.2.9	Config Register 1 or 2: Cache Line Size Register (read/write, bit 7-0; offset 0Ch)	60
13.2.10	Config Register 1: Primary Latency Timer Register (read/write, bit 15-8; offset 0Ch)	60
13.2.11	Config Register 2: Primary Latency Timer Register (read/write, bit 15-8; offset 0Ch)	60
13.2.12	Config Register 1: Header Type Register (read only, bit 23-16; offset 0Ch)	60
13.2.13	Config Register 2: Header Type Register (read only, bit 23-16; offset 0Ch)	60
13.2.14	Config Register 1: Primary Bus Number Register (read/write, bit 7-0; offset 18h)	60
13.2.15	Config Register 2: Primary Bus Number Register (read/write, bit 7-0; offset 18h)	60
13.2.16	Config Register 1 or 2: Secondary Bus Number Register (read/write, bit 15-8; offset 18h)	60
13.2.17	Config Register 1 or 2: Subordinate Bus Number Register (read/write, bit 23-16; offset 18h)	60
13.2.18	Config Register 1 or 2: Secondary Latency Timer (read/write, bit 31-24; offset 18h)	60
13.2.19	Config Register 1 or 2: I/O Base Register (read/write, bit 7-0; offset 1Ch)	60
13.2.20	Config Register 1 or 2: I/O Limit Register (read/write, bit 15-8; offset 1Ch)	60
13.2.21	Config Register 1 or 2: Secondary Status Register (bit 31-16; offset 1Ch)	61
13.2.22	Config Register 1 or 2: Memory Base Register (read/write, bit 15-0; offset 20h)	62
13.2.23	Config Register 1 or 2: Memory Limit Register (read/write, bit 31-16; offset 20h)	62
13.2.24	Config Register 1 or 2: Prefetchable Memory Base Register (read/write, bit 15-0; offset 24h)	62
13.2.25	Config Register 1 or 2: Prefetchable Memory Limit Register (read/write, bit 31-16; offset 24h)	62
13.2.26	Config Register 1 or 2: I/O Base Address Upper 16 Bits Register (read/write, bit 15-0; offset 30h)	62
13.2.27	Config Register 1 or 2: I/O Limit Address Upper 16 Bits Register (read/write, bit 31-16; offset 30h)	62
13.2.28	Config Register 1 or 2: Subsystem Vendor ID (read/write, bit 15-0; offset 34h)	62
13.2.29	Config Register 1 or 2: Subsystem ID (read/write, bit 31-16; offset 34h)	62
13.2.30	Config Register 1 or 2: Interrupt Pin Register (read only, bit 15-8; offset 3Ch)	62
13.2.31	Config Register 1 or 2: Bridge Control Register (bit 31-16; offset 3Ch)	63
13.2.32	Config Register 1 or 2: Diagnostic/Chip Control Register (bit 15-0; offset 40h)	64
13.2.33	Config Register 1 or 2: Arbiter Control Register (bit 31-16; offset 40h)	64
13.2.34	Config Register 1: Primary Prefetchable Memory Base Register (Read/Write, bit 15-0; offset 44h)	65
13.2.35	Config Register 2: Primary Prefetchable Memory Base Register (Read/Write, bit 15-0; offset 44h)	65
13.2.36	Config Register 1: Primary Prefetchable Memory Limit Register (Read/Write, bit 31-16; offset 44h)	65
13.2.37	Config Register 2: Primary Prefetchable Memory Limit Register (Read/Write, bit 31-16; offset 44h)	65
13.2.38	Config Register 1 or 2: P_SERR# Event Disable Register (bit 7-0; offset 64h)	65
13.2.39	Config Register 1: Secondary Clock Control Register (bit 15-0; offset 68h)	66
13.2.40	Config Register 2: Secondary Clock Control Register (bit 15-0; offset 68h)	66
13.2.41	Config Register 1 or 2: Non-Posted Memory Base Register (read/write, bit 15-0; offset 70h)	67
13.2.42	Config Register 1 or 2: Non-Posted Memory Limit Register (read/write, bit 31-16; offset 70h)	67
13.2.43	Config Register 1: Port Option Register (bit 15-0; offset 74h)	67
13.2.44	Config Register 2: Port Option Register (bit 15-0; offset 74h)	68
13.2.45	Config Register 1 or 2: Master Timeout Counter Register (read/write, bit 31-16; offset 74h)	69
13.2.46	Config Register 1 or 2: Retry Counter Register (read/write, bit 31-0; offset 78h)	69
13.2.47	Config Register 1 or 2: Sampling Timer Register (read/write, bit 31-0; offset 7Ch)	69
13.2.48	Config Register 1 or 2: Successful I/O Read Count Register (read/write, bit 31-0; offset 80h)	69



13.2.49 Config Register 1 or 2: Successful I/O Write Count Register (read/write, bit 31-0; offset 84h) 69

13.2.50 Config Register 1 or 2: Successful Memory Read Count Register (read/write, bit 31-0; offset 88h) 69

13.2.51 Config Register 1 or 2: Successful Memory Write Count Register (read/write, bit 31-0; offset 8Ch) 69

13.2.52 Config Register 1: Primary Successful I/O Read Count Register (read/write, bit 31-0; offset 90h) 69

13.2.53 Config Register 1: Primary Successful I/O Write Count Register (read/write, bit 31-0; offset 94h) 69

13.2.54 Config Register 1: Primary Successful Memory Read Count Register (read/write, bit 31-0; offset 98h) 69

13.2.55 Config Register 1: Primary Successful Memory Write Count Register (read/write, bit 31-0; offset 9Ch) 69

14. Bridge Behavior 70

14.1 Bridge Actions for Various Cycle Types 70

14.2 Transaction Ordering 70

14.3 Abnormal Termination (Initiated by Bridge Master) 71

14.3.1 Master Abort 71

14.3.2 Parity and Error Reporting 71

14.3.3 Reporting Parity Errors 71

14.3.4 Secondary IDSEL mapping 71

15. IEEE 1149.1 Compatible JTAG Controller 72

15.1 Boundary Scan Architecture 72

15.1.1 TAP Pins 72

15.1.2 Instruction Register 72

15.2 Boundary Scan Instruction Set 73

15.3 TAP Test Data Registers 74

15.4 Bypass Register 74

15.5 Boundary-Scan Register 74

15.6 TAP Controller 74

16. Electrical and Timing Specifications 79

16.1 Maximum Ratings 79

16.2 3.3V DC Specifications 79

16.3 3.3V AC Specifications 80

16.4 Primary and Secondary buses at 33 MHz clock timing 80

16.5 Power Consumption 80

17. 256-Pin PBGA Package 81

17.1 Part Number Ordering Information 81



List of Figures

1-1. PI7C7100 on the System Board 2
1-2. PI7C7100 in Redundant Applications 2
1-3. PI7C7100 on Network Switching Hub 2
2-1. PI7C7100 Block Diagram 3
9-1. Secondary Arbiter Example 48
15-1. Test Access Port Block Diagram 72
16-1. PCI Signal Timing Measurement Conditions 80
17-1. 256-Pin PBGA Package Drawing 81

List of Tables

4-1. PCI Transaction 13
4-2. Write Transaction Forwarding 14
4-3. Write Transaction Disconnect Address Boundaries 16
4-4. Read Pre-fetch Address Boundaries 17
4-5. Read Transaction Pre-fetching 18
4-6. Device Number to IDSEL S1_AD or S2_AD Pin Mapping 21
4-7. Delayed Write Target Termination Response 24
4-8. Responses to Posted Write Target Termination 25
4-9. Responses to Delayed Read Target Termination 25
6-1. Summary of Transaction Ordering 33
7-1. Setting the Primary Interface Detected Parity Error Bit 39
7-2. Setting the Secondary Interface Detected Parity Error Bit 40
7-3. Setting the Primary Interface Data Parity Detected Bit 40
7-4. Setting the Secondary Interface Data Parity Detected Bit 41
7-5. Assertion of P_PERR# 42
7-6. Assertion of S_PERR# 43
7-7. Assertion of P_SERR# for Data Parity Errors 44
15-1. TAP Pins 73
15-2. JTAG Boundary Register Order 75



Appendix A - Timing Diagrams

1. Configuration Read Transaction	A-3
2. Configuration Write Transaction	A-3
3. Type 1 to Type 0 Configuration Read Transaction (P →S)	A-3
4. Type 1 to Type 0 Configuration Write Transaction (P →S)	A-4
5. Upstream Type 1 to Special Cycle Transaction (S →P)	A-4
6. Downstream Type 1 to Special Cycle Transaction (P →S)	A-5
7. Downstream Type 1 to Type 1 Configuration Read Transaction (P →S)	A-5
8. Downstream Type 1 to Type 1 Configuration Write Transaction (P →S)	A-6
9. Upstream Delayed Burst Memory Read Transaction (S →P)	A-6
10. Downstream Delayed Burst Memory Read Transaction (P →S)	A-7
11. Downstream Delayed Memory Read Transaction (P/33MHz →S/33MHz)	A-7
12. Downstream Delayed Memory Read Transaction (S2/33MHz →S1/33MHz)	A-8
13. Downstream Delayed Memory Read Transaction (S1/33MHz →S2/33MHz)	A-8
14. Upstream Delayed Memory Read Transaction (S/33MHz →P/33MHz)	A-9
15. Downstream Posted Memory Write Transaction (P/33MHz →S/33MHz)	A-9
16. Downstream Posted Memory Write Transaction (S2/33MHz →S1/33MHz)	A-10
17. Downstream Posted Memory Write Transaction (S1/33MHz →S2/33MHz)	A-10
18. Upstream Posted Memory Write Transaction (S/33MHz →P/33MHz)	A-11
19. Downstream Flow-Through Posted Memory Write Transaction (P/33MHz →S/33MHz)	A-11
20. Downstream Flow-Through Posted Memory Write Transaction (S2/33MHz →S1/33MHz)	A-12
21. Downstream Flow-Through Posted Memory Write Transaction (S1/33MHz →S2/33MHz)	A-12
22. Upstream Flow-Through Posted Memory Write Transaction (S/33MHz →P/33MHz)	A-13
23. Downstream Delayed I/O Read Transaction (P →S)	A-13
24. Downstream Delayed I/O Read Transaction (S2/33MHz →S1/33MHz)	A-14
25. Downstream Delayed I/O Read Transaction (S1/33MHz →S2/33MHz)	A-14
26. Downstream Delayed I/O Read Transaction (S/33MHz →P/33MHz)	A-15
27. Downstream Delayed I/O Write Transaction (P →S)	A-15
28. Downstream Delayed I/O Write Transaction (S2/33MHz →S1/33MHz)	A-16
29. Downstream Delayed I/O Write Transaction (S1/33MHz →S2/33MHz)	A-16
30. Upstream Delayed I/O Write Transaction (S →P)	A-17

Appendix B - Evaluation Board User's Manual

General Information	B-3
Frequently Asked Questions	B-5

Appendix C - Three-Port PCI Bridge Evaluation Board Schematics

PCI Chip	C-3
PCI Edge Connector	C-4
Secondary 1 PCI Bus	C-5
Secondary 2 PCI Bus	C-6
Top View	C-7

Appendix D - Representatives and Distributors

1. Introduction

Product Description

PI7C7100 is the first triple port PCI-to-PCI Bridge device designed to be fully compliant with the 32-bit, 33 MHz implementation of the *PCI Local Bus Specification, Revision 2.1*. PI7C7100 supports only synchronous bus transactions between devices on the primary 33 MHz bus and the secondary buses operating at 33 MHz. The primary and the secondary buses can also operate in concurrent mode, resulting in added increase in system performance. Concurrent bus operation off-loads and isolates unnecessary traffic from the primary bus; thereby enabling a master and a target device on the same secondary PCI bus to communicate even while the primary bus is busy.

Product Features

- 32-bit Primary & two Secondary Ports run up to 33 MHz
- All three ports compliant with the PCI Local Bus Specification, Revision 2.1
- Compliant with PCI-to-PCI Bridge Architecture Specification, Revision 1.0.
 - All I/O and memory commands
 - Type 1 to Type 0 configuration conversion
 - Type 1 to Type 1 configuration forwarding
 - Type 1 configuration-write to special cycle conversion
- Concurrent primary to secondary bus operation and independent intra-secondary port channel to reduce traffic on the primary port
- Provides internal arbitration for two sets of eight secondary bus masters
 - Programmable 2-level priority arbiter
 - Disable control for use of external arbiter
- Supports posted write buffers on all directions
- Three 128 byte FIFOs for delay transactions
- Three 128 byte FIFOs for posted memory transactions
- Enhanced address decoding
 - 32-bit I/O address range
 - 32-bit memory-mapped I/O address range
 - VGA addressing and VGA palette snooping
 - ISA-aware mode for legacy support in the first 64KB of I/O address range
- Interrupt Handling
 - PCI interrupts are routed through an external interrupt concentrator
- Supports system transaction ordering rules
- Hot-plug support on secondary buses
 - 3-State control of output buffers
- IEEE 1149.1 JTAG interface support
- 3.3V core; 3.3V PCI I/O interface with 5V I/O Tolerant
- 256-pin plastic BGA package

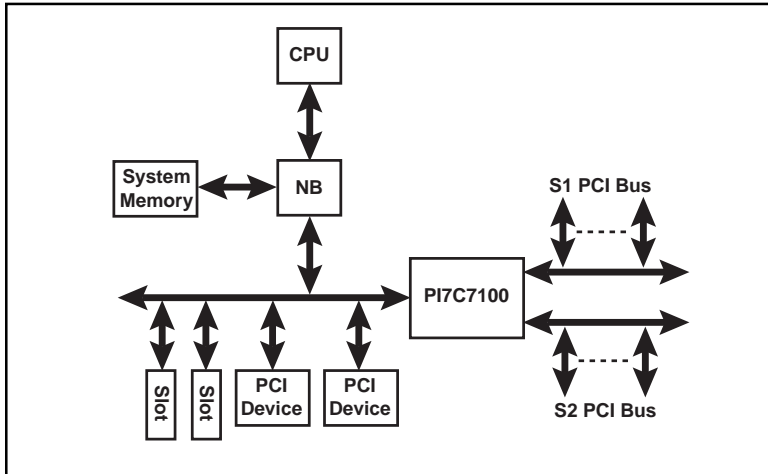
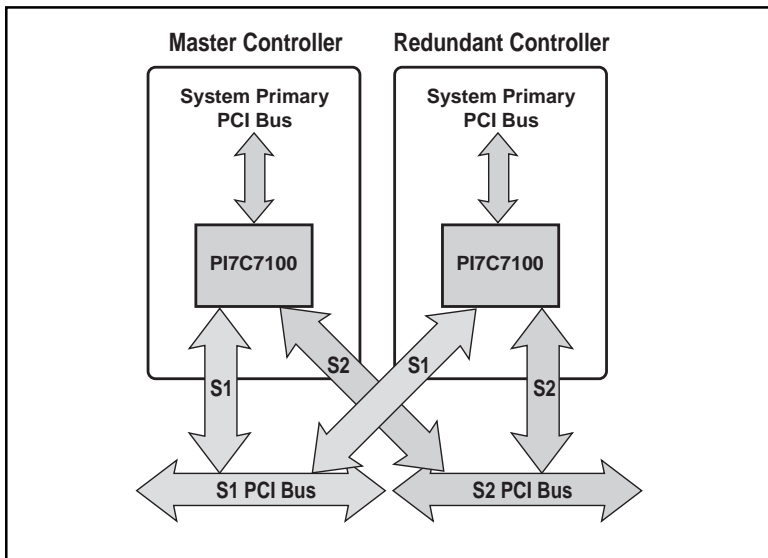
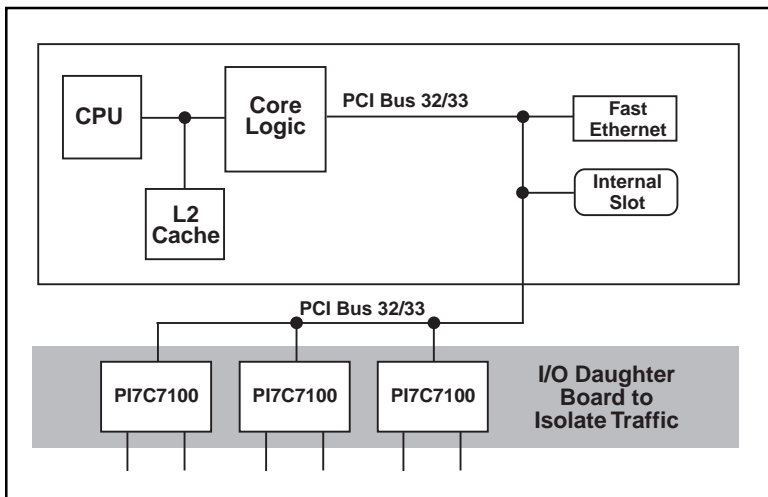
Figure 1-1. PI7C7100 on the System Board

Figure 1-2. PI7C7100 in Redundant Application

Figure 1-3. PI7C7100 on Network Switching Hub

2. PI7C7100 Block Diagram

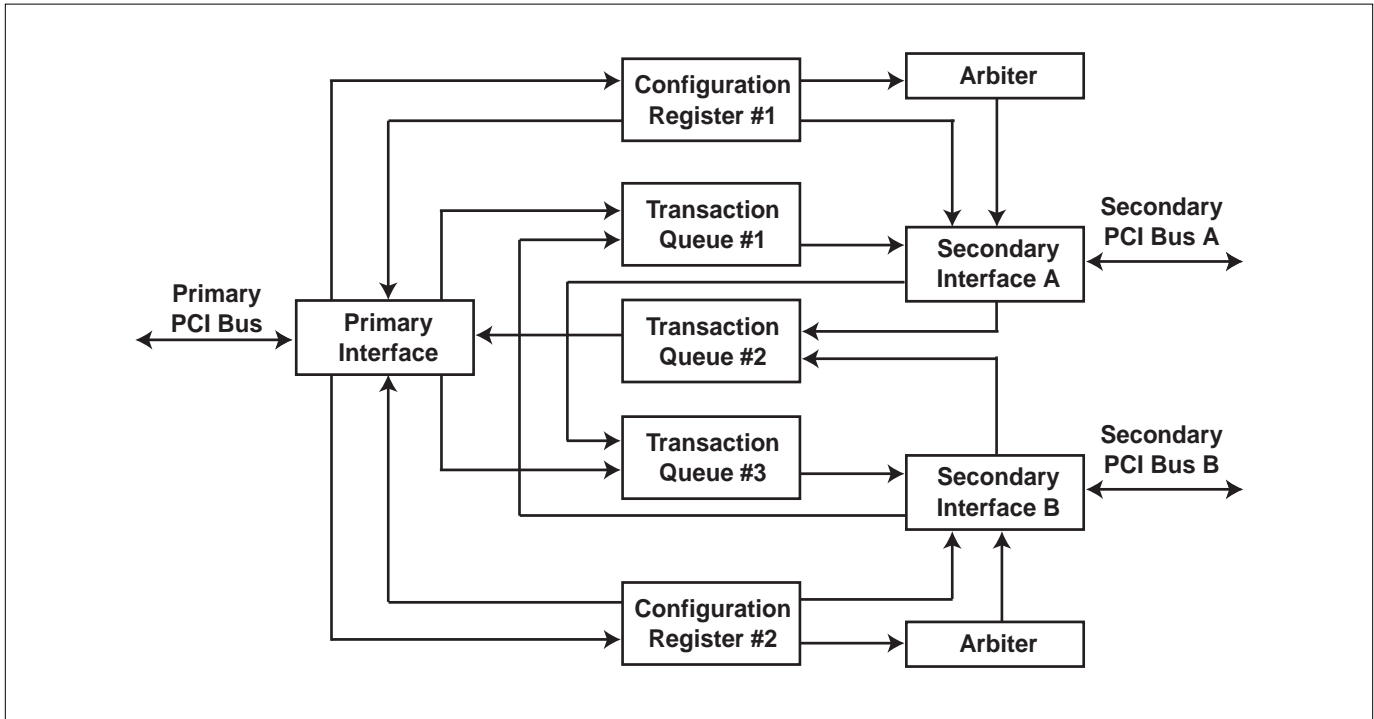

Figure 2-1. PI7C7100 Block Diagram



3. Signal Definitions

3.1 Signal Types

Signal Type	Description
PI	PCI Input (3.3V, 5V tolerant)
PIU	PCI Input (3.3V, 5V tolerant) with weak pull-up
PB	PCI 3-state bidirectional (3.3V, 5V tolerant)
PO	PCI Output (3.3V)
PSTS	PCI Sustained 3-state bidirectional (Active LOW signal which must be driven inactive for one cycle before being 3-stated to ensure HIGH performance on a shared signal line)
PTS	PCI 3-state Output
POD	PCI Output which either drives LOW (active state) or 3-stated
CI	CMOS Input
CIU	CMOS Input with weak pull-up
CID	CMOS Input with weak pull-down
CTO	CMOS 3-state Output

3.2 Signals (Note: Signal name that ends with character '#' is active LOW.)

3.2.1 Primary Bus Interface Signals

Name	Pin #	Type	Description
P_AD[31:0]	Y7, W7, Y8, W8, V8, U8, Y9, W9, W10, V10, Y11, V11, U11, Y12, W12, V12, V16, W16, Y16, W17, Y17, U18, W18, Y18, U19, W19, Y19, U20, V20, Y20, T17, R17	PB	Primary Address/Data. Multiplexed address and data bus. Address is indicated by P_FRAME# assertion. Write data is stable and valid when P_IRDY# is asserted and read data is stable and valid when P_TRDY# is asserted. Data is transferred on rising clock edges when both P_IRDY# and P_TRDY# are asserted. During bus idle, PI7C7100 drives P_AD to a valid logic level when P_GNT# is asserted.
P_CBE[3:0]	V9, U12, U16, V19	PB	Primary Command/Byte Enables. Multiplexed command field and byte enable field. During address phase, the initiator drives the transaction type on these pins. After that the initiator drives the byte enables during data phases. During bus idle, PI7C7100 drives P_CBE[3:0] to a valid logic level when P_GNT# is asserted.
P_PAR	U15	PB	Primary Parity. Parity is even across P_AD[31:0], P_CBE[3:0], and P_PAR (i.e. an even number of '1's). P_PAR is an input and is valid and stable one cycle after the address phase (indicated by assertion of P_FRAME#) for address parity. For write data phases, P_PAR is an input and is valid one clock after P_IRDY# is asserted. For read data phase, P_PAR is an output and is valid one clock after P_TRDY# is asserted. Signal P_PAR is tri-stated one cycle after the PAD lines are 3-stated. During bus idle, PI7C7100 drives PPAR to a valid logic level when P_GNT# is asserted.
P_FRAME#	W13	PSTS	Primary FRAME (Active LOW). Driven by the initiator of a transaction to indicate the beginning and duration of an access. The de-assertion of P_FRAME# indicates the final data phase requested by the initiator. Before being 3-stated, it is driven to a de-asserted state for one cycle.



3.2.1 Primary Bus Interface Signals (continued)

Name	Pin #	Type	Description
P_IRDY#	V13	PSTS	Primary IRDY (Active LOW). Driven by the initiator of a transaction to indicate its ability to complete current data phase on the primary side. Once asserted in a data phase, it is not de-asserted until end of data phase. Before being 3-stated, it is driven to a de-asserted state for one cycle.
P_TRDY#	U13	PSTS	Primary TRDY (Active LOW). Driven by the target of a transaction to indicate its ability to complete current data phase on the primary side. Once asserted in a data phase, it is not de-asserted until end of data phase. Before being 3-stated, it is driven to a de-asserted state for one cycle.
P_DEVSEL#	Y14	PSTS	Primary Device Select (Active LOW). Asserted by the target indicating that the device is accepting the transaction. As a master, PI7C7100 waits for the assertion of this signal within 5 cycles of P_FRAME# assertion; otherwise, terminate with master abort. Before being 3-stated, it is driven to a de-asserted state for one cycle.
P_STOP#	W14	PSTS	Primary STOP (Active LOW). Asserted by the target indicating that the target is requesting the initiator to stop the current transaction. Before being 3-stated, it is driven to a de-asserted state for one cycle.
P_LOCK#	V14	PSTS	Primary LOCK (Active LOW). Asserted by master for multiple transactions to complete.
P_IDSEL	Y10	PI	Primary ID Select. Used as chip select line for Type 0 configuration access to PI7C7100 configuration space.
P_PERR#	Y15	PSTS	Primary Parity Error (Active LOW). Asserted when a data parity error is detected for data received on the primary interface. Before being 3-stated, it is driven to a de-asserted state for one cycle.
P_SERR#	W15	POD	Primary System Error (Active LOW). Can be driven LOW by any device to indicate a system error condition, PI7C7100 drives this pin on: <ul style="list-style-type: none"> • Address parity error • Posted write data parity error on target bus • Secondary S1_SERR# or S2_SERR# asserted • Master abort during posted write transaction • Target abort during posted write transaction • Posted write transaction discarded • Delayed write request discarded • Delayed read request discarded • Delayed transaction master timeout This signal requires an external pull-up resistor for proper operation.
P_REQ#	W6	PTS	Primary Request (Active LOW). This is asserted by PI7C7100 to indicate that it wants to start a transaction on the primary bus. PI7C7100 de-asserts this pin for at least 2 PCI clock cycles before asserting it again.
P_GNT#	U7	PI	Primary Grant (Active LOW). When asserted, PI7C7100 can access the primary bus. During idle and P_GNT# asserted, PI7C7100 will drive P_AD, P_CBE and P_PAR to valid logic levels.
P_RESET#	Y5	PI	Primary RESET (Active LOW). When P_RESET# is active, all PCI signals should be asynchronously 3-stated.
P_FLUSH#	W5	PI	Primary FIFO FLUSH (Active LOW). When P_FLUSH# is active, all primary FIFO(s) are cleared (invalidate all primary transactions). This signal should be pulled to a static "high."
P_M66EN	V18	–	Reserved for Future Use. Must be tied to ground.



3.2.2 Secondary Bus Interface Signals

Name	Pin #	Type	Description
S1_AD[31:0], S2_AD[31:0]	B20, B19, C20, C19, C18, D20, D19, D17, E19, E18, E17, F20, F19, F17, G20, G19, L20, L19, L18, M20, M19, M17, N20, N19, N18, N17, P17, R20, R19, R18, T20, T19 J4, H1, H2, H3, H4, G1, G3, G4, F2, F3, F4, E1, E4, D1, C1, B1, C5, B5, D6, C6, B6, A6, C7, B7, D8, C8, D9, C9, B9, A9, D10, C10	PB	Secondary Address/Data. Multiplexed address and data bus. Address is indicated by S1_FRAME# or S2_FRAME# assertion. Write data is stable and valid when S1_IRDY# or S2_IRDY# is asserted and read data is stable and valid when S1_TRDY# or S2_TRDY# is asserted. Data is transferred on rising clock edges when both S1_IRDY# and S1_TRDY# or S2_IRDY# and S2_TRDY# are asserted. During bus idle, PI7C7100 drives S1_AD or S2_AD to a valid logic level when the S1_GNT# or S2_GNT# is asserted respectively.
S1_CBE[3:0], S2_CBE[3:0]	E20, G18, K17, P20 F1, A1, A4, A7	PB	Secondary Command/Byte Enables. Multiplexed command field and byte enable field. During the address phase, the initiator drives the transaction type on these pins. After that the initiator drives the byte enables during data phases. During bus idle, PI7C7100 drives S1_CBE[3:0] or S2_CBE[3:0] to a valid logic level when the internal grant is asserted.
S1_PAR, S2_PAR	K18, B4	PB	Secondary Parity. Parity is even across S1_AD[31:0], S1_CBE[3:0], and S1_PAR or S2_AD[31:0], S2_CBE[3:0], and S2_PAR (i.e. an even number of '1's). S1_PAR or S2_PAR is an input and is valid and stable one cycle after the address phase (indicated by assertion of S1_FRAME# or S2_FRAME#) for address parity. For write data phases, S1_PAR or S2_PAR is an input and is valid one clock after S1_IRDY# or S2_IRDY# is asserted. For read data phase, S1_PAR or S2_PAR is an output and is valid one clock after S1_TRDY# or S2_TRDY# is asserted. Signal S1_PAR or S2_PAR is 3-stated one cycle after the S1_AD or S2_AD lines are tri-stated. During bus idle, PI7C7100 drives S1_PAR or S2_PAR to a valid logic level when the internal grant is asserted.
S1_FRAME#, S2_FRAME#	H20, D2	PSTS	Secondary FRAME (Active LOW). Driven by the initiator of a transaction to indicate the beginning and duration of an access. De-assertion of S1_FRAME# or S2_FRAME# indicates the final data phase requested by initiator. Before being 3-stated, it is driven to a de-asserted state for one cycle.
S1_IRDY#, S2_IRDY#	H19, B2	PSTS	Secondary IRDY (Active LOW). Driven by the initiator of a transaction to indicate its ability to complete the current data phase on the primary side. Once asserted in a data phase, it is not de-asserted until end of the data phase. Before being 3-stated, it is driven to a de-asserted state for one cycle.
S1_TRDY#, S2_TRDY#	H18, A2	PSTS	Secondary TRDY (Active LOW). Driven by the target of a transaction to indicate its ability to complete the current data phase on the primary side. Once asserted in a data phase, it is not de-asserted until end of the data phase. Before being 3-stated, it is driven to a de-asserted state for one cycle.
S1_DEVSEL#, S2_DEVSEL#	J20, D3	PSTS	Secondary Device Select (Active LOW). Asserted by the target indicating that the device is accepting the transaction. As a master, PI7C7100 waits for the assertion of this signal within 5 cycles of S1_FRAME# or S2_FRAME# assertion; otherwise, terminate with master abort. Before being 3-stated, it is driven to a de-asserted state for one cycle.



3.2.2 Secondary Bus Interface Signals (continued)

Name	Pin #	Type	Description
S1_STOP#, S2_STOP#	J19, C3	PSTS	Secondary STOP (Active LOW). Asserted by the target indicating that the target is requesting the initiator to stop the current transaction. Before being 3-stated, it is driven to a de-asserted state for one cycle.
S1_LOCK#, S2_LOCK#	J18, B3	PSTS	Secondary LOCK (Active LOW). Asserted by master for multiple transactions to complete.
S1_PERR#, S2_PERR#	J17, D4	PSTS	Secondary Parity Error (Active LOW). Asserted when a data parity error is detected for data received on the secondary interface. Before being 3-stated, it is driven to a de-asserted state for one cycle.
S1_SERR#, S2_SERR#	K20, C4	PI	Secondary System Error (Active LOW). Can be driven LOW by any device to indicate a system error condition.
S1_REQ#[7:0], S2_REQ#[7:0]	B11, A12, D13, C13, C15, A16, C17, B17 T2, R3, P2, P1, M2, M1, K1, K3	PIU	Secondary Request (Active LOW). This is asserted by an external device to indicate that it wants to start a transaction on the Secondary bus. The input is externally pulled up through a resistor to VDD.
S1_GNT#[7:0], S2_GNT#[7:0]	C11, B12, B13, A14, D14, B16, D16, B18 U1, P4, R1, N4, M3, L4, L1, K2	PO	Secondary Grant (Active LOW). PI7C7100 asserts this pin to access the secondary bus. PI7C7100 de-asserts this pin for at least 2 PCI clock cycles before asserting it again. During idle and S1_GNT# or S2_GNT# asserted, PI7C7100 will drive S1_AD, S1_CBE and S1_PAR or S2_AD, S2_CBE and S2_PAR to valid logic levels.
S1_RESET#, S2_RESET#	B10, T4	PO	Secondary RESET (Active LOW). Asserted when any of the following conditions are met: 1. Signal P_RESET# is asserted. 2. Secondary reset bit in bridge control register in configuration space is set. When asserted, all control signals are 3-stated and zeros are driven on S1_AD, S1_CBE, and S1_PAR or S2_AD, S2_CBE, and S2_PAR.
S1_EN, S2_EN	W3, W4	PIU	Secondary Enable (Active HIGH). When S1_EN or S2_EN is inactive, secondary PCI S1 or S2 bus will be asynchronously 3-stated.
S_M66EN	D7	–	Reserved for Future Use. Must be tied to ground.
S_CFN#	Y2	CIU	Secondary Bus Central Function Control Pin. When tied LOW, it enables the internal arbiter. When tied HIGH, an external arbiter must be used. S1_REQ0# or S2_REQ0# is reconfigured to be the secondary bus grant input, and S1_GNT0# or S2_GNT0# is reconfigured to be the secondary bus request output.

3.2.3 Clock Signals

Name	Pin #	Type	Description
P_CLK	V6	PI	Primary Clock Input. Provides timing for all transaction on primary interface.
S_CLKOUT [15:0]	T3, T1, P3, N3, M4, L3, L2, J1, A11, C12, A13, B14, B15, C16, A18, A19	PTS	Secondary Clock Output. Provides secondary clocks phase synchronous with the P_CLK.

3.2.4 Miscellaneous Signals

Name	Pin #	Type	Description
BYPASS	Y4	–	Reserved for Future Use. Must be tied HIGH.
PLL_TM	Y3	–	Reserved for Future Use. Must be tied LOW.
S_CLKIN	V5	PI	Secondary Test Clock Input. It should be tied to LOW in normal mode. It also may be a secondary clock input for the secondary buses if both SCAN_TM# and SCAN_EN are connected to logic "1".
SCAN_TM#	V4	CI	Full-scan Test Mode enable (Active LOW). When SCAN_TM# is active, the twelve scan chains will be enabled. The scan clock is P_CLK. The scan inputs and outputs are as follows: S1_REQ[7], S1_REQ[6], S1_REQ[5], S1_REQ[4], S1_REQ[3], S1_REQ[2], S2_REQ[7], S2_REQ[6], S2_REQ[5], S2_REQ[4], S2_REQ[3], S2_REQ[2] and S1_GNT[7], S1_GNT[6], S1_GNT[5], S1_GNT[4], S1_GNT[3], S1_GNT[2], S2_GNT[7], S2_GNT[6], S2_GNT[5], S2_GNT[4], S2_GNT[3], S2_GNT[2] respectively
SCAN_EN	U5	CIU	Full-scan Enable Control. When SCAN_EN is LOW, full-scan is in shift operation if SCAN_TM# is active. When SCAN_EN is HIGH, full-scan is in parallel operation if SCAN_TM# is active. SCAN_EN should be tied LOW in normal mode. If SCAN_TM# and SCAN_EN are connected to logic "1", S_CLKIN is the clock source for the internal secondary clock. If SCAN_TM# is connected to logic "1" and SCAN_EN is connected to logic "0", P_CLK is the clock source for the internal secondary clock. Note: During power-up, SCAN_EN is the reset signal for the on-chip PLL.
CMPO1	U6	–	Reserved for Future Use.
Reserved	R4		Reserved

3.2.5 JTAG Boundary Scan Signals

Name	Pin #	Type	Description
TCK	V2	CIU	Test Clock. Used to clock state information and data into and out of the PI7C7100 during boundary scan.
TMS	W1	CIU	Test Mode Select. Used to control the state of the Test Access Port controller.
TDO	V3	CTO	Test Data Output. When SCANEN is HIGH it is used (in conjunction with TCK) to shift data out of the Test Access Port (TAP) in a serial bit stream.
TDI	W2	CIU	Test Data Input. When SCANEN is HIGH it is used (in conjunction with TCK) to shift data and instructions into the Test Access Port (TAP) a serial bit stream.
TRST#	U3	CIU	Test Reset. Active LOW signal to reset the Test Access Port (TAP) controller into an initialized state.



3.2.6 Power and Ground

Name	Pin #	Type	Description
VDD	B8, C14, D5, D11, D15, E2, F18, J3, L17, N2, P19, U10, V1, V7, V15, W20		+3.3V Digital Power
VSS	A3, A5, A8, A10, A15, A17, A20, C2, D12, D18, E3, G2, G17, H17, J2, K4, K19, M18, N1, P18, R2, T18, U2, U9, U14, U17 V17 W11 Y6 Y13		Digital Ground
AVCC	Y1		Analog 3.3V for PLL
AGND	U4		Analog Ground for PLL

3.3 PI7C7100 PBGA Pin List

Pin No.	Name	Type	Pin No.	Name	Type
A1	S2_CBE[2]	PB	A2	S2_TRDY#	PSTS
A3	VSS	–	A4	S2_CBE[1]	PB
A5	VSS	–	A6	S2_AD[10]	PB
A7	S2_CBE[0]	PB	A8	VSS	–
A9	S2_AD[2]	PB	A10	VSS	–
A11	S_CLKOUT[7]	PTS	A12	S1_REQ#[6]	PIU
A13	S_CLKOUT[5]	PTS	A14	S1_GNT#[6]	PO
A15	VSS	–	A16	S1_REQ#[2]	PIU
A17	VSS	–	A18	S_CLKOUT[1]	PTS
A19	S_CLKOUT[0]	PTS	A20	VSS	–
B1	S2_AD[16]	PB	B2	S2_IRDY#	PSTS
B3	S2_LOCK#	PSTS	B4	S2_PAR	PB
B5	S2_AD[14]	PB	B6	S2_AD[11]	PB
B7	S2_AD[8]	PB	B8	VDD	–
B9	S2_AD[3]	PB	B10	S1_RESET#	PO
B11	S1_REQ#[7]	PIU	B12	S1_GNT#[6]	PO
B13	S1_GNT#[7]	PO	B14	S_CLKOUT[4]	PTS
B15	S_CLKOUT[3]	PTS	B16	S1_GNT#[2]	PO
B17	S1_REQ#[0]	PIU	B18	S1_GNT#[0]	PO
B19	S1_AD[30]	PB	B20	S1_AD[31]	PB
C1	S2_AD[17]	PB	C2	VSS	–
C3	S2_STOP#	PSTS	C4	S2_SER#	PI
C5	S2_AD[15]	PB	C6	S2_AD[12]	PB
C7	S2_AD[9]	PB	C8	S2_AD[6]	PB
C9	S2_AD[4]	PB	C10	S2_AD[0]	PB
C11	S1_GNT#[7]	PO	C12	S_CLKOUT[6]	PTS
C13	S1_REQ#[4]	PIU	C14	VDD	–
C15	S1_REQ#[3]	PIU	C16	S_CLKOUT[2]	PTS



3.3 PI7C7100 PBGA Pin List (continued)

Pin No.	Name	Type	Pin No.	Name	Type
C17	S1_REQ#[1]	PIU	C18	S1_AD[27]	PB
C19	S1_AD[28]	PB	C20	S1_AD[29]	PB
D1	S2_AD[18]	PB	D2	S2_FRAME#	PSTS
D3	S2_DEVSEL#	PSTS	D4	S2_PERR#	PSTS
D5	VDD	–	D6	S2_AD[13]	PB
D7	S_M66EN	–	D8	S2_AD[7]	PB
D9	S2_AD[5]	PB	D10	S2_AD[1]	PB
D11	VDD	–	D12	VSS	–
D13	S1_REQ#[5]	PIU	D14	S1_GNT#[3]	PO
D15	VDD	–	D16	S1_GNT#[1]	PO
D17	S1_AD[24]	PB	D18	VSS	–
D19	S1_AD[25]	PB	D20	S1_AD[26]	PB
E1	S2_AD[20]	PB	E2	VDD	–
E3	VSS	–	E4	S2_AD[19]	PB
E17	S1_AD[21]	PB	E18	S1_AD[22]	PB
E19	S1_AD[23]	PB	E20	S1_CBE[3]	PB
F1	S2_CBE[3]	PB	F2	S2_AD[23]	PB
F3	S2_AD[22]	PB	F4	S2_AD[21]	PB
F17	S1_AD[18]	PB	F18	VDD	–
F19	S1_AD[19]	PB	F20	S1_AD[20]	PB
G1	S2_AD[26]	PB	G2	VSS	–
G3	S2_AD[25]	PB	G4	S2_AD[24]	PB
G17	VSS	–	G18	S1_CBE[2]	PB
G19	S1_AD[16]	PB	G20	S1_AD[17]	PB
H1	S2_AD[30]	PB	H2	S2_AD[29]	PB
H3	S2_AD[28]	PB	H4	S2_AD[27]	PB
H17	VSS	–	H18	S1_TRDY#	PSTS
H19	S1_IRDY#	PSTS	H20	S1_FRAME#	PSTS
J1	S_CLKOUT[8]	PTS	J2	VSS	–
J3	VDD	–	J4	S2_AD[31]	PB
J17	S1_PERR#	PSTS	J18	S1_LOCK#	PSTS
J19	S1_STOP#	PSTS	J20	S1_DEVSEL#	PSTS



3.3 PI7C7100 PBGA Pin List (continued)

Pin No.	Name	Type	Pin No.	Name	Type
K1	S2_REQ#[1]	PIU	K2	S2_GNT#[0]	PO
K3	S2_REQ#[0]	PIU	K4	VSS	–
K17	S1_CBE[1]	PB	K18	S1_PAR	PB
K19	VSS	–	K20	S1_SERR#	PI
L1	S2_GNT#[1]	PO	L2	S_CLKOUT[9]	PTS
L3	S_CLKOUT[10]	PTS	L4	S2_GNT#[2]	PO
L17	VDD	–	L18	S1_AD[13]	PB
L19	S1_AD[14]	PB	L20	S1_AD[15]	PB
M1	S2_REQ#[2]	PIU	M2	S2_REQ#[3]	PIU
M3	S2_GNT#[3]	PO	M4	S_CLKOUT[11]	PTS
M17	S1_AD[10]	PB	M18	VSS	–
M19	S1_AD[11]	PB	M20	S1_AD[12]	PB
N1	VSS	–	N2	VDD	–
N3	S_CLKOUT[12]	PTS	N4	S2_GNT#[4]	PO
N17	S1_AD[6]	PB	N18	S1_AD[7]	PB
N19	S1_AD[8]	PB	N20	S1_AD[9]	PB
P1	S2_REQ#[4]	PIU	P2	S2_REQ#[5]	PIU
P3	S_CLKOUT[13]	PTS	P4	S2_GNT#[6]	PO
P17	S1_AD[5]	PB	P18	VSS	–
P19	VDD	–	P20	S1_CBE[0]	PB
R1	S2_GNT#[5]	PO	R2	VSS	–
R3	S2_REQ#[6]	PIU	R4	Reserved	–
R17	P_AD[0]	PB	R18	S1_AD[2]	PB
R19	S1_AD[3]	PB	R20	S1_AD[4]	PB
T1	S_CLKOUT[14]	PTS	T2	S2_REQ#[7]	PIU
T3	S_CLKOUT[15]	PTS	T4	S2_RESET#	PO
T17	P_AD[1]	PB	T18	VSS	–
T19	S1_AD[0]	PB	T20	S1_AD[1]	PB
U1	S2_GNT#[7]	PO	U2	VSS	–
U3	TRST#	CIU	U4	AGND	–
U5	SCAN_EN	CIU	U6	CMPO1	–
U7	P_GNT#	PI	U8	P_AD[26]	PB



3.3 PI7C7100 PBGA Pin List (continued)

Pin No.	Name	Type	Pin No.	Name	Type
U9	VSS	–	U10	VDD	–
U11	P_AD[19]	PB	U12	P_CBE[2]	
U13	P_TRDY#	PB	U14	VSS	–
U15	P_PAR	PB	U16	P_CBE[1]	PB
U17	VSS	–	U18	P_AD[10]	PB
U19	P_AD[7]	PB	U20	P_AD[4]	PB
V1	VDD	–	V2	TCK	CIU
V3	TDO	CTO	V4	SCAN_TM#	CI
V5	S_CLKIN	PI	V6	P_CLK	PI
V7	VDD	–	V8	P_AD[27]	PB
V9	P_CBE[3]	PB	V10	P_AD[22]	PB
V11	P_AD[20]	PB	V12	P_AD[16]	PB
V13	P_IRDY#	PB	V14	P_LOCK#	PSTS
V15	VDD	–	V16	P_AD[15]	PB
V17	VSS	–	V18	P_M66EN	–
V19	P_CBE[0]	PB	V20	P_AD[3]	PB
W1	TMS	CIU	W2	TDI	CIU
W3	S1_EN	PIU	W4	S2_EN	PIU
W5	P_FLUSH#	PI	W6	P_REQ#	PTS
W7	P_AD[30]	PB	W8	P_AD[28]	PB
W9	P_AD[24]	PB	W10	P_AD[23]	PB
W11	VSS	–	W12	P_AD[17]	PB
W13	P_FRAME#	PB	W14	P_STOP#	PSTS
W15	P_SERR#	POD	W16	P_AD[14]	PB
W17	P_AD[12]	PB	W18	P_AD[9]	PB
W19	P_AD[6]	PB	W20	VDD	–
Y1	AVCC	–	Y2	S_CFN#	CIU
Y3	PLL_TM	–	Y4	BYPASS	–
Y5	P_RESET#	PI	Y6	VSS	–
Y7	P_AD[31]	PB	Y8	P_AD[29]	PB
Y9	P_AD[25]	PB	Y10	P_IDSEL	PI
Y11	P_AD[21]	PB	Y12	P_AD[18]	PB
Y13	VSS	–	Y14	P_DEVSEL#	PSTS
Y15	P_PERR#	PSTS	Y16	P_AD[13]	PB
Y17	P_AD[11]	PB	Y18	P_AD[8]	PB
Y19	P_AD[5]	PB	Y20	P_AD[2]	PB

4. PCI Bus Operation

This chapter offers information about PCI transactions, transaction forwarding across PI7C7100, and transaction termination. The PI7C7100 has three 128-byte buffers for buffering of upstream and downstream transactions. These hold addresses, data, commands, and byte enables and are used for both read and write transactions.

4.1 Types of Transactions

This section provides a summary of PCI transactions performed by PI7C7100. Table 4–1 lists the command code and name of each PCI transaction. The Master and Target columns indicate support for each transaction when PI7C7100 initiates transactions as a master, on the primary (P) and secondary (S1, S2) buses, and when PI7C7100 responds to transactions as a target, on the primary (P) and secondary (S1, S2) buses.

Table 4-1. PCI Transactions

Type of Transactions		Initiates as Master		Responds as Target	
		Primary	Secondary	Primary	Secondary
0000	Interrupt acknowledge	N	N	N	N
0001	Special cycle	Y	Y	N	N
0010	I/O read	Y	Y	Y	Y
0011	I/O write	Y	Y	Y	Y
0100	Reserved	N	N	N	N
0101	Reserved	N	N	N	N
0110	Memory read	Y	Y	Y	Y
0111	Memory write	Y	Y	Y	Y
1000	Reserved	N	N	N	N
1001	Reserved	N	N	N	N
1010	Configuration read	N	Y	Y	N
1011	Configuration write	Y (Type 1 only)	Y	Y	Y (Type 1 only)
1100	Memory read multiple	Y	Y	Y	Y
1101	Dual address cycle	N	N	N	N
1110	Memory read line	Y	Y	Y	Y
1111	Memory write and invalidate	N	N	Y	Y

As indicated in Table 4–1, the following PCI commands are not supported by PI7C7100:

- PI7C7100 never initiates a PCI transaction with a reserved command code and, as a target, PI7C7100 ignores reserved command codes.
- PI7C7100 does not generate interrupt acknowledge transactions. PI7C7100 ignores interrupt acknowledge transactions as a target.
- PI7C7100 does not respond to special cycle transactions. PI7C7100 cannot guarantee delivery of a special cycle transaction to downstream buses because of the broadcast nature of the special cycle command and the inability to control the transaction as a target. To generate special cycle transactions on other PCI buses, either upstream or downstream, Type 1 configuration write must be used.
- PI7C7100 neither generates Type 0 configuration transactions on the primary PCI bus nor responds to Type 0 configuration transactions on the secondary PCI buses.
- PI7C7100 does not support DAC (Dual Address Cycle) transactions.

4.2 Single Address Phase

A 32-bit address uses a single address phase. This address is driven on P_AD[31:0], and the bus command is driven on P_CBE[3:0]. PI7C7100 supports the linear increment address mode only, which is indicated when the lowest two address bits are equal to zero. If either of the lowest two address bits is nonzero, PI7C7100 automatically disconnects the transaction after the first data transfer.

4.3 Device Select (DEVSEL#) Generation

PI7C7100 always performs positive address decoding (medium decode) when accepting transactions on either the primary or secondary buses. PI7C7100 never does subtractive decode.

4.4 Data Phase

The address phase of a PCI transaction is followed by one or more data phases. A data phase is completed when IRDY# and either TRDY# or STOP# are asserted. A transfer of data occurs only when both IRDY# and TRDY# are asserted during the same PCI clock cycle. The last data phase of a transaction is indicated when FRAME# is de-asserted and both TRDY# and IRDY# are asserted, or when IRDY# and STOP# are asserted. See Section 4.8 for further discussion of transaction termination.

Depending on the command type, PI7C7100 can support multiple data phase PCI transactions. For a detailed description of how PI7C7100 imposes disconnect boundaries, see Section 4.5.4 for write address boundaries and Section 4.6.3 read address boundaries.

4.5 Write Transactions

Write transactions are treated as either posted write or delayed write transactions. Table 4-2 shows the method of forwarding used for each type of write operation.

Table 4-2. Write Transaction Forwarding

Type of Transaction	Type of Forwarding
Memory write	Posted (except VGA memory)
Memory write and invalidate	Posted
I/O write	Delayed
Type 1 configuration write	Delayed

For timing diagrams, see Figures 15-22 and 27-30 in Appendix A

4.5.1 Posted Write Transactions

Posted write forwarding is used for “Memory Write” and “Memory Write and Invalidate” transactions.

When PI7C7100 determines that a memory write transaction is to be forwarded across the bridge, PI7C7100 asserts DEVSEL# with medium timing and TRDY# in the next cycle, provided that enough buffer space is available in the posted memory write queue for the address and at least one DWORD of data. Under this condition, PI7C7100 accepts write data without obtaining access to the target bus. The PI7C7100 can accept one DWORD of write data every PCI clock cycle. That is, no target wait state is inserted. The write data is stored in an internal posted write buffers and is subsequently delivered to the target.

The PI7C7100 continues to accept write data until one of the following events occurs:

- The initiator terminates the transaction by de-asserting FRAME# and IRDY#.
- An internal write address boundary is reached, such as a cache line boundary or an aligned 4KB boundary, depending on the transaction type.
- The posted write data buffer fills up.



When one of the last two events occurs, the PI7C7100 returns a target disconnect to the requesting initiator on this data phase to terminate the transaction.

Once the posted write data moves to the head of the posted data queue, PI7C7100 asserts its request on the target bus. This can occur while PI7C7100 is still receiving data on the initiator bus. When the grant for the target bus is received and the target bus is detected in the idle condition, PI7C7100 asserts FRAME# and drives the stored write address out on the target bus. On the following cycle, PI7C7100 drives the first DWORD of write data and continues to transfer write data until all write data corresponding to that transaction is delivered, or until a target termination is received. As long as write data exists in the queue, PI7C7100 can drive one DWORD of write data each PCI clock cycle; that is, no master wait states are inserted. If write data is flowing through PI7C7100 and the initiator stalls, PI7C7100 will signal the last data phase for the current transaction at the target bus if the queue empties. PI7C7100 will restart the follow-on transactions if the queue has new data.

PI7C7100 ends the transaction on the target bus when one of the following conditions is met:

- All posted write data has been delivered to the target.
- The target returns a target disconnect or target retry (PI7C7100 starts another transaction to deliver the rest of write data).
- The target returns a target abort (PI7C7100 discards remaining write data).
- The master latency timer expires, and PI7C7100 no longer has the target bus grant (PI7C7100 starts another transaction to deliver remaining write data).

Section 4.8.3.2 provides detailed information about how PI7C7100 responds to target termination during posted write transactions.

4.5.2 Memory Write and Invalidate Transactions

Posted write forwarding is used for Memory Write and Invalidate transactions.

PI7C7100 always converts Memory Write and Invalidate transactions to Memory Write transactions.

The PI7C7100 disconnects Memory Write and Invalidate commands at aligned cache line boundaries. The cache line size value in the cache line size register gives the number of DWORD in a cache line.

If the value in the cache line size register does not meet the memory write and invalidate conditions, the PI7C7100 returns a target disconnect to the initiator either on a cache line boundary or when the posted write buffer fills.

When the Memory Write and Invalidate transaction is disconnected before a cache line boundary is reached, typically because the posted write buffer fills, the transaction is converted to Memory Write transaction.

4.5.3 Delayed Write Transactions

Delayed write forwarding is used for I/O write transactions and Type 1 configuration write transactions.

A delayed write transaction guarantees that the actual target response is returned back to the initiator without holding the initiating bus in wait states. A delayed write transaction is limited to a single DWORD data transfer.

When a write transaction is first detected on the initiator bus, and PI7C7100 forwards it as a delayed transaction, PI7C7100 claims the access by asserting DEVSEL# and returns a target retry to the initiator. During the address phase, PI7C7100 samples the bus command, address, and address parity one cycle later. After IRDY# is asserted, PI7C7100 also samples the first data DWORD, byte enable bits, and data parity. This information is placed into the delayed transaction queue. The transaction is queued only if no other existing delayed transactions have the same address and command, and if the delayed transaction queue is not full. When the delayed write transaction moves to the head of the delayed transaction queue and all ordering constraints with posted data are satisfied. The PI7C7100 initiates the transaction on the target bus. PI7C7100 transfers the write data to the target. If PI7C7100 receives a target retry in response to the write transaction on the target bus, it continues to repeat the write transaction until the data transfer is completed, or until an error condition is encountered.

If PI7C7100 is unable to deliver write data after 2²⁴ (default) or 2³² (maximum) attempts, PI7C7100 will report a system error. PI7C7100 also asserts P_SERR# if the primary SERR# enable bit is set in the command register. See Section 7.4 for information on the assertion of P_SERR#. When the initiator repeats the same write transaction (same command, address, byte enable bits, and data), and the completed delayed transaction is at the head of the queue, the PI7C7100



claims the access by asserting DEVSEL# and returns TRDY# to the initiator, to indicate that the write data was transferred. If the initiator requests multiple DWORD, PI7C7100 also asserts STOP# in conjunction with TRDY# to signal a target disconnect. Note that only those bytes of write data with valid byte enable bits are compared. If any of the byte enable bits are turned off (driven HIGH), the corresponding byte of write data is not compared.

If the initiator repeats the write transaction before the data has been transferred to the target, PI7C7100 returns a target retry to the initiator. PI7C7100 continues to return a target retry to the initiator until write data is delivered to the target, or until an error condition is encountered. When the write transaction is repeated, PI7C7100 does not make a new entry into the delayed transaction queue. Section 4.8.3.1 provides detailed information about how PI7C7100 responds to target termination during delayed write transactions.

PI7C7100 implements a discard timer that starts counting when the delayed write completion is at the head of the delayed transaction queue. The initial value of this timer can be set to the retry counter register offset 78h. If the initiator does not repeat the delayed write transaction before the discard timer expires, PI7C7100 discards the delayed write completion from the delayed transaction queue. PI7C7100 also conditionally asserts P_SERR# (see Section 7.4).

4.5.4 Write Transaction Address Boundaries

PI7C7100 imposes internal address boundaries when accepting write data. The aligned address boundaries are used to prevent PI7C7100 from continuing a transaction over a device address boundary and to provide an upper limit on maximum latency. PI7C7100 returns a target disconnect to the initiator when it reaches the aligned address boundaries under conditions shown in Table 4-3.

Table 4-3. Write Transaction Disconnect Address Boundaries

Type of Transaction	Condition	Aligned Address Boundary
Delayed write	All	Disconnects after one data transfer
Posted memory write	Cache line size not equal to 1, 2, 4, 8, 16	4KB aligned address boundary
Posted memory write	Cache line size = 1, 2, 4, 8, 16	Disconnects at cache line boundary
Posted memory write and invalidate	Cache line size not equal to 1, 2, 4, 8, 16	4KB aligned address boundary
Posted memory write and invalidate	Cache line size = 1, 2, 4, 8, 16	Cache line boundary,

Note 1. Memory-write-disconnect-control bit is bit 1 of the chip control register at offset 40h in configuration space.

4.5.5 Buffering Multiple Write Transactions

PI7C7100 continues to accept posted memory write transactions as long as space for at least one DWORD of data in the posted write data buffer remains. If the posted write data buffer fills before the initiator terminates the write transaction, PI7C7100 returns a target disconnect to the initiator.

Delayed write transactions are posted as long as at least one open entry in the delayed transaction queue exists. Therefore, several posted and delayed write transactions can exist in data buffers at the same time. See Chapter 6 for information about how multiple posted and delayed write transactions are ordered.

4.5.6 Fast Back-to-Back Write Transactions

PI7C7100 can recognize and post fast back-to-back write transactions. When PI7C7100 cannot accept the second transaction because of buffer space limitations, it returns a target retry to the initiator.

4.6 Read Transactions

Delayed read forwarding is used for all read transactions crossing PI7C7100. Delayed read transactions are treated as either prefetchable or non-prefetchable. Table 4-4 shows the read behavior, prefetchable or non-prefetchable, for each type of read operation. For Timing diagrams, see Figures 11-14 and 23-26 in Appendix A

4.6.1 Prefetchable Read Transactions

A prefetchable read transaction is a read transaction where PI7C7100 performs speculative DWORD reads, transferring data from the target before it is requested from the initiator. This behavior allows a prefetchable read transaction to consist of multiple data transfers. However, byte enable bits cannot be forwarded for all data phases as is done for the single data phase of the non-prefetchable read transaction. For prefetchable read transactions, PI7C7100 forces all byte enable bits to be turned on for all data phases.

Prefetchable behavior is used for memory read line and memory read multiple transactions, as well as for memory read transactions that fall into prefetchable memory space.

The amount of data that is pre-fetched depends on the type of transaction. The amount of pre-fetching may also be affected by the amount of free buffer space available in PI7C7100, and by any read address boundaries encountered.

Pre-fetching should not be used for those read transactions that have side effects in the target device, that is, control and status registers, FIFOs, and so on. The target device's base address register or registers indicate if a memory address region is prefetchable.

4.6.2 Non-prefetchable Read Transactions

A non-prefetchable read transaction is a read transaction where PI7C7100 requests one and only one DWORD from the target and disconnects the initiator after delivery of the first DWORD of read data. Unlike prefetchable read transactions, PI7C7100 forwards the read byte enable information for the data phase.

Non-prefetchable behavior is used for I/O and configuration read transactions, as well as for memory read transactions that fall into non-prefetchable memory space.

If extra read transactions could have side effects, for example, when accessing a FIFO, use non-prefetchable read transactions to those locations. Accordingly, if it is important to retain the value of the byte enable bits during the data phase, use non-prefetchable read transactions. If these locations are mapped in memory space, use the memory read command and map the target into non-prefetchable (memory-mapped I/O) memory space to use non-prefetching behavior.

4.6.3 Read Pre-fetch Address Boundaries

PI7C7100 imposes internal read address boundaries on read pre-fetched data. When a read transaction reaches one of these aligned address boundaries, the PI7C7100 stops pre-fetched data, unless the target signals a target disconnect before the read pre-fetched boundary is reached. When PI7C7100 finishes transferring this read data to the initiator, it returns a target disconnect with the last data transfer, unless the initiator completes the transaction before all pre-fetched read data is delivered. Any leftover pre-fetched data is discarded.

Prefetchable read transactions in flow-through mode pre-fetch to the nearest aligned 4KB address boundary, or until the initiator de-asserts FRAME#. Section 4.6.6 describes flow-through mode during read operations.

Table 4-5 shows the read pre-fetch address boundaries for read transactions during non-flow-through mode.

Table 4-4. Read Pre-fetch Address Boundaries

Type of Transaction	Address Space	Cache Line Size (CLS)	Pre-fetch Aligned Address Boundary
Config read	-	-	One DWORD (no pre-fetch)
I/O read	-	-	One DWORD (no pre-fetch)
Memory read	Non-prefetchable	-	One DWORD (no pre-fetch)
Memory read	Prefetchable	CLS not equal to 1, 2, 4, 8	16-DWORD aligned address boundary
Memory read	Prefetchable	CLS = 1, 2, 4, 8	Cache line address boundary
Memory read line	-	CLS not equal to 1, 2, 4, 8	16-DWORD aligned address boundary
Memory read line	-	CLS = 1, 2, 4, 8	Cache line boundary
Memory read multiple	-	CLS not equal to 1, 2, 4, 8	32-DWORD aligned address boundary
Memory read multiple	-	CLS = 1, 2, 4, 8	2 times of cache line boundary

Table 4-5. Read Transaction Pre-Fetching

Type of Transaction	Read Behavior
I/O read	Pre-fetching never done
Configuration read	Pre-fetching never done
Memory read	Downstream: pre-fetching used if address in prefetchable space
	Upstream: pre-fetching used
Memory read line	Pre-fetching always used
Memory read multiple	Pre-fetching always used

See Section 5.3 for detailed information about prefetchable and non-prefetchable address spaces.

4.6.4 Delayed Read Requests

PI7C7100 treats all read transactions as delayed read transactions, which means that the read request from the initiator is posted into a delayed transaction queue. Read data from the target is placed in the read data queue directed toward the initiator bus interface and is transferred to the initiator when the initiator repeats the read transaction.

When PI7C7100 accepts a delayed read request, it first samples the read address, read bus command, and address parity. When IRDY# is asserted, PI7C7100 then samples the byte enable bits for the first data phase. This information is entered into the delayed transaction queue. PI7C7100 terminates the transaction by signaling a target retry to the initiator. Upon reception of the target retry, the initiator is required to continue to repeat the same read transaction until at least one data transfer is completed, or until a target response (target abort or master abort) other than a target retry is received.

4.6.5 Delayed Read Completion with Target

When delayed read request reaches the head of the delayed transaction queue, PI7C7100 arbitrates for the target bus and initiates the read transaction only if all previously queued posted write transactions have been delivered. PI7C7100 uses the exact read address and read command captured from the initiator during the initial delayed read request to initiate the read transaction. If the read transaction is a non-prefetchable read, PI7C7100 drives the captured byte enable bits during the next cycle. If the transaction is a prefetchable read transaction, it drives all byte enable bits to zero for all data phases. If PI7C7100 receives a target retry in response to the read transaction on the target bus, it continues to repeat the read transaction until at least one data transfer is completed, or until an error condition is encountered. If the transaction is terminated via normal master termination or target disconnect after at least one data transfer has been completed, PI7C7100 does not initiate any further attempts to read more data.

If PI7C7100 is unable to obtain read data from the target after 2²⁴(default) or 2³²(maximum) attempts, PI7C7100 will report system error. The number of attempts is programmable. PI7C7100 also asserts P_SERR# if the primary SERR# enable bit is set in the command register. See Section 7.4 for information on the assertion of P_SERR#.

Once PI7C7100 receives DEVSEL# and TRDY# from the target, it transfers the data read to the opposite direction read data queue, pointing toward the opposite interface, before terminating the transaction. For example, read data in response to a downstream read transaction initiated on the primary bus is placed in the upstream read data queue. The PI7C7100 can accept one DWORD of read data each PCI clock cycle; that is, no master wait states are inserted. The number of DWORD transferred during a delayed read transaction depends on the conditions given in Table 4-5 (assuming no disconnect is received from the target).

4.6.6 Delayed Read Completion on Initiator Bus

When the transaction has been completed on the target bus, and the delayed read data is at the head of the read data queue, and all ordering constraints with posted write transactions have been satisfied, the PI7C7100 transfers the data to the initiator when the initiator repeats the transaction. For memory read transactions, PI7C7100 aliases the memory read, memory read line, and memory read multiple bus commands when matching the bus command of the transaction to the bus command in the delayed transaction queue. PI7C7100 returns a target disconnect along with the transfer of the last DWORD of read data to the initiator. If PI7C7100 initiator terminates the transaction before all read data has been transferred, the remaining read data left in data buffers is discarded.



When the master repeats the transaction and starts transferring prefetchable read data from data buffers while the read transaction on the target bus is still in progress and before a read boundary is reached on the target bus, the read transaction starts operating in flow-through mode. Because data is flowing through the data buffers from the target to the initiator, long read bursts can then be sustained. In this case, the read transaction is allowed to continue until the initiator terminates the transaction, or until an aligned 4KB address boundary is reached, or until the buffer fills, whichever comes first. When the buffer empties, PI7C7100 reflects the stalled condition to the initiator by de-asserting TRDY# until more read data is available; otherwise, PI7C7100 does not insert any target wait states. When the initiator terminates the transaction, PI7C7100 de-assertion of FRAME# on the initiator bus is forwarded to the target bus. Any remaining read data is discarded.

PI7C7100 implements a discard timer that starts counting when the delayed read completion is at the head of the delayed transaction queue, and the read data is at the head of the read data queue. The initial value of this timer is programmable through configuration register. If the initiator does not repeat the read transaction and before the discard timer expires (2^{15} default), PI7C7100 discards the read transaction and read data from its queues. PI7C7100 also conditionally asserts P_SERR# (see Section 7.4).

PI7C7100 has the capability to post multiple delayed read requests, up to a maximum of four in each direction. If an initiator starts a read transaction that matches the address and read command of a read transaction that is already queued, the current read command is not posted as it is already contained in the delayed transaction queue.

See Section 6 for a discussion of how delayed read transactions are ordered when crossing PI7C7100.

4.7 Configuration Transactions

Configuration transactions are used to initialize a PCI system. Every PCI device has a configuration space that is accessed by configuration commands. All registers are accessible in configuration space only.

In addition to accepting configuration transactions for initialization of its own configuration space, the PI7C7100 also forwards configuration transactions for device initialization in hierarchical PCI systems, as well as for special cycle generation.

To support hierarchical PCI bus systems, two types of configuration transactions are specified: Type 0 and Type 1.

Type 0 configuration transactions are issued when the intended target resides on the same PCI bus as the initiator. A Type 0 configuration transaction is identified by the configuration command and the lowest two bits of the address set to 00b.

Type 1 configuration transactions are issued when the intended target resides on another PCI bus, or when a special cycle is to be generated on another PCI bus. A Type 1 configuration command is identified by the configuration command and the lowest two address bits set to 01b.

The register number is found in both Type 0 and Type 1 formats and gives the DWORD address of the configuration register to be accessed. The function number is also included in both Type 0 and Type 1 formats and indicates which function of a multifunction device is to be accessed. For single-function devices, this value is not decoded. The addresses of Type 1 configuration transaction include a 5-bit field designating the device number that identifies the device on the target PCI bus that is to be accessed. In addition, the bus number in Type 1 transactions specifies the PCI bus to which the transaction is targeted. For timing diagrams, see Figures 1-8 in Appendix A.

4.7.1 Type 0 Access to PI7C7100

The configuration space is accessed by a Type 0 configuration transaction on the primary interface. The configuration space cannot be accessed from the secondary bus. The PI7C7100 responds to a Type 0 configuration transaction by asserting P_DEVSEL# when the following conditions are met during the address phase:

- The bus command is a configuration read or configuration write transaction.
- Lowest two address bits P_AD[1:0] must be 00b.
- Signal P_IDSEL must be asserted.

Function code is either 0 for configuration space of S1, or 1 for configuration space of S2 as PI7C7100 is a multi-function device.

PI7C7100 limits all configuration access to a single DWORD data transfer and returns target-disconnect with the first data transfer if additional data phases are requested. Because read transactions to configuration space do not have side effects, all bytes in the requested DWORD are returned, regardless of the value of the byte enable bits.



Type 0 configuration write and read transactions do not use data buffers; that is, these transactions are completed immediately, regardless of the state of the data buffers. The PI7C7100 ignores all Type 0 transactions initiated on the secondary interface.

4.7.2 Type 1 to Type 0 Conversion

Type 1 configuration transactions are used specifically for device configuration in a hierarchical PCI bus system. A PCI-to-PCI bridge is the only type of device that should respond to a Type 1 configuration command. Type 1 configuration commands are used when the configuration access is intended for a PCI device that resides on a PCI bus other than the one where the Type 1 transaction is generated.

PI7C7100 performs a Type 1 to Type 0 translation when the Type 1 transaction is generated on the primary bus and is intended for a device attached directly to the secondary bus. PI7C7100 must convert the configuration command to a Type 0 format so that the secondary bus device can respond to it. Type 1 to Type 0 translations are performed only in the downstream direction; that is, PI7C7100 generates a Type 0 transaction only on the secondary bus, and never on the primary bus.

PI7C7100 responds to a Type 1 configuration transaction and translates it into a Type 0 transaction on the secondary bus when the following conditions are met during the address phase:

- The lowest two address bits on P_AD[1:0] are 01b.
- The bus number in address field P_AD[23:16] is equal to the value in the secondary bus number register in configuration space.
- The bus command on P_CBE[3:0] is a configuration read or configuration write transaction.
- When PI7C7100 translates the Type 1 transaction to a Type 0 transaction on the secondary interface, it performs the following translations to the address:
 - Sets the lowest two address bits on S1_AD[1:0] or S2_AD[1:0] to 00b.
 - Decodes the device number and drives the bit pattern specified in Table 4–6 on S1_AD[31:16] or S2_AD[31:16] for the purpose of asserting the device's IDSEL signal.
 - Sets S1_AD[15:11] or S2_AD[15:11] to 0.
 - Leaves unchanged the function number and register number fields.

PI7C7100 asserts a unique address line based on the device number. These address lines may be used as secondary bus IDSEL signals. The mapping of the address lines depends on the device number in the Type 1 address bits P_AD[15:11]. Table 4–6 presents the mapping that PI7C7100 uses



Table 4–6. Device Number to IDSEL S1_AD or S2_AD Pin Mapping

Device Number	P_AD<15:11>	Secondary IDSEL S1_AD[31:16] or S2_AD[31:16]	S1_AD or S2_AD Bit
0h	00000	0000 0000 0000 0001	16
1h	00001	0000 0000 0000 0010	17
2h	00010	0000 0000 0000 0100	18
3h	00011	0000 0000 0000 1000	19
4h	00100	0000 0000 0001 0000	20
5h	00101	0000 0000 0010 0000	21
6h	0110	0000 0000 0100 0000	22
7h	00111	0000 0000 1000 0000	23
8h	01000	0000 0001 0000 0000	24
9h	01001	0000 0010 0000 0000	25
Ah	01010	0000 0100 0000 0000	26
Bh	01011	0000 1000 0000 0000	27
Ch	01100	0001 0000 0000 0000	28
Dh	01101	0010 0000 0000 0000	29
Eh	01110	0100 0000 0000 0000	30
Fh	01111	1000 0000 0000 0000	31
10h-1Eh	10000-11110	0000 0000 0000 0000	-
1Fh	11111	Generate special cycle (P_AD[7:2] = 00h) 0000 0000 0000 0000 (P_AD[7:2] = 00h)	-

PI7C7100 can assert up to 16 unique address lines to be used as IDSEL signals for up to 16 devices on the secondary bus, for device numbers ranging from 0 through 15. Because of electrical loading constraints of the PCI bus, more than 16 IDSEL signals should not be necessary. However, if device numbers greater than 15 are desired, some external method of generating IDSEL lines must be used, and no upper address bits are then asserted. The configuration transaction is still translated and passed from the primary bus to the secondary bus. If no IDSEL pin is asserted to a secondary device, the transaction ends in a master abort.

PI7C7100 forwards Type 1 to Type 0 configuration read or write transactions as delayed transactions. Type 1 to Type 0 configuration read or write transactions are limited to a single 32-bit data transfer.

4.7.3 Type 1 to Type 1 Forwarding

Type 1 to Type 1 transaction forwarding provides a hierarchical configuration mechanism when two or more levels of PCI-to-PCI bridges are used.

When PI7C7100 detects a Type 1 configuration transaction intended for a PCI bus downstream from the secondary bus, PI7C7100 forwards the transaction unchanged to the secondary bus. Ultimately, this transaction is translated to a Type 0 configuration command or to a special cycle transaction by a downstream PCI-to-PCI bridge. Downstream Type 1 to Type 1 forwarding occurs when the following conditions are met during the address phase:

- The lowest two address bits are equal to 01b.
- The bus number falls in the range defined by the lower limit (exclusive) in the secondary bus number register and the upper limit (inclusive) in the subordinate bus number register.
- The bus command is a configuration read or write transaction.

PI7C7100 also supports Type 1 to Type 1 forwarding of configuration write transactions upstream to support upstream special cycle generation. A Type 1 configuration command is forwarded upstream when the following conditions are met:

- The lowest two address bits are equal to 01b.
- The bus number falls outside the range defined by the lower limit (inclusive) in the secondary bus number register and the upper limit (inclusive) in the subordinate bus number register.
- The device number in address bits AD[15:11] is equal to 11111b.
- The function number in address bits AD[10:8] is equal to 111b.
- The bus command is a configuration write transaction.

The PI7C7100 forwards Type 1 to Type 1 configuration write transactions as delayed transactions. Type 1 to Type 1 configuration write transactions are limited to a single data transfer.

4.7.4 Special Cycles

The Type 1 configuration mechanism is used to generate special cycle transactions in hierarchical PCI systems. Special cycle transactions are ignored by acting as a target and are not forwarded across the bridge. Special cycle transactions can be generated from Type 1 configuration write transactions in either the upstream or the downstream direction.

PI7C7100 initiates a special cycle on the target bus when a Type 1 configuration write transaction is being detected on the initiating bus and the following conditions are met during the address phase:

- The lowest two address bits on AD[1:0] are equal to 01b.
- The device number in address bits AD[15:11] is equal to 11111b.
- The function number in address bits AD[10:8] is equal to 111b.
- The register number in address bits AD[7:2] is equal to 000000b.
- The bus number is equal to the value in the secondary bus number register in configuration space for downstream forwarding or equal to the value in the primary bus number register in configuration space for upstream forwarding.
- The bus command on CBE# is a configuration write command.

When PI7C7100 initiates the transaction on the target interface, the bus command is changed from configuration write to special cycle. The address and data are forwarded unchanged. Devices that use special cycles ignore the address and decode only the bus command. The data phase contains the special cycle message. The transaction is forwarded as a delayed transaction, but in this case the target response is not forwarded back (because special cycles result in a master abort). Once the transaction is completed on the target bus, through detection of the master abort condition, PI7C7100 responds with TRDY# to the next attempt of the configuration transaction from the initiator. If more than one data transfer is requested, PI7C7100 responds with a target disconnect operation during the first data phase.

4.8 Transaction Termination

This section describes how PI7C7100 returns transaction termination conditions back to the initiator.

The initiator can terminate transactions with one of the following types of termination:

- **Normal termination**

Normal termination occurs when the initiator de-asserts FRAME# at the beginning of the last data phase, and de-asserts IRDY# at the end of the last data phase in conjunction with either TRDY# or STOP# assertion from the target.

- **Master abort**

A master abort occurs when no target response is detected. When the initiator does not detect a DEVSEL# from the target within five clock cycles after asserting FRAME#, the initiator terminates the transaction with a master abort. If FRAME# is still asserted, the initiator de-asserts FRAME# on the next cycle, and then de-asserts IRDY# on the following cycle. IRDY# must be asserted in the same cycle in which FRAME# de-asserts. If FRAME# is already de-asserted, IRDY# can be de-asserted on the next clock cycle following detection of the master abort condition.



The target can terminate transactions with one of the following types of termination:

- **Normal termination**—TRDY# and DEVSEL# asserted in conjunction with FRAME# de-asserted and IRDY# asserted.
- **Target retry**—STOP# and DEVSEL# asserted with TRDY# de-asserted during the first data phase. No data transfers occur during the transaction. This transaction must be repeated.
- **Target disconnect with data transfer**—STOP#, DEVSEL# and TRDY# asserted. It signals that this is the last data transfer of the transaction.
- **Target disconnect without data transfer**—STOP# and DEVSEL# asserted with TRDY# de-asserted after previous data transfers have been made. Indicates that no more data transfers will be made during this transaction.
- **Target abort**—STOP# asserted with DEVSEL# and TRDY# de-asserted.

Indicates that target will never be able to complete this transaction. DEVSEL# must be asserted for at least one cycle during the transaction before the target abort is signaled.

4.8.1 Master Termination Initiated by PI7C7100

PI7C7100, as an initiator, uses normal termination if DEVSEL# is returned by target within five clock cycles of PI7C7100's assertion of FRAME# on the target bus. As an initiator, PI7C7100 terminates a transaction when the following conditions are met:

- During a delayed write transaction, a single DWORD is delivered.
- During a non-prefetchable read transaction, a single DWORD is transferred from the target.
- During a prefetchable read transaction, a pre-fetch boundary is reached.
- For a posted write transaction, all write data for the transaction is transferred from data buffers to the target.
- For burst transfer, with the exception of "Memory Write and Invalidate" transactions, the master latency timer expires and the PI7C7100's bus grant is de-asserted.
- The target terminates the transaction with a retry, disconnect, or target abort.

If PI7C7100 is delivering posted write data when it terminates the transaction because the master latency timer expires, it initiates another transaction to deliver the remaining write data. The address of the transaction is updated to reflect the address of the current DWORD to be delivered.

If PI7C7100 is pre-fetching read data when it terminates the transaction because the master latency timer expires, it does not repeat the transaction to obtain more data.

4.8.2 Master Abort Received by PI7C7100

If the initiator initiates a transaction on the target bus and does not detect DEVSEL# returned by the target within five clock cycles of the assertion of FRAME#, PI7C7100 terminates the transaction with a master abort. This sets the received-master-abort bit in the status register corresponding to the target bus.

For delayed read and write transactions, PI7C7100 is able to reflect the master abort condition back to the initiator. When PI7C7100 detects a master abort in response to a delayed transaction, and when the initiator repeats the transaction, PI7C7100 does not respond to the transaction with DEVSEL# which induces the master abort condition back to the initiator. The transaction is then removed from the delayed transaction queue. When a master abort is received in response to a posted write transaction, PI7C7100 discards the posted write data and makes no more attempt to deliver the data. PI7C7100 sets the received-master-abort bit in the status register when the master abort is received on the primary bus, or it sets the received master abort bit in the secondary status register when the master abort is received on the secondary interface. When master abort is detected in posted write transaction with both master-abort-mode bit (bit 5 of bridge control register) and the SERR# enable bit (bit 8 of command register for secondary bus S1 or S2) are set, PI7C7100 asserts P_SERR# if the master-abort-on-posted-write is not set. The master-abort-on-posted-write bit is bit 4 of the P_SERR# event disable register (offset 64h).

Note: When PI7C7100 performs a Type 1 to special cycle conversion, a master abort is the expected termination for the special cycle on the target bus. In this case, the master abort received bit is not set, and the Type 1 configuration transaction is disconnected after the first data phase.

4.8.3 Target Termination Received by PI7C7100

When PI7C7100 initiates a transaction on the target bus and the target responds with DEVSEL#, the target can end the transaction with one of the following types of termination:

- Normal termination (upon de-assertion of FRAME#)
- Target retry
- Target disconnect
- Target abort

PI7C7100 handles these terminations in different ways, depending on the type of transaction being performed.

4.8.3.1 Delayed Write Target Termination Response

When PI7C7100 initiates a delayed write transaction, the type of target termination received from the target can be passed back to the initiator. Table 4–7 shows the response to each type of target termination that occurs during a delayed write transaction.

PI7C7100 repeats a delayed write transaction until one of the following conditions is met:

- PI7C7100 completes at least one data transfer.
- PI7C7100 receives a master abort.
- PI7C7100 receives a target abort.

PI7C7100 makes 2²⁴(default) or 2³²(maximum) write attempts resulting in a response of target retry.

Table 4-7. Delayed Write Target Termination Response

Target Termination	Response
Normal	Returning disconnect to initiator with first data transfer only if multiple data phases requested.
Target retry	Returning target retry to initiator. Continue write attempts to target.
Target disconnect	Returning disconnect to initiator with first data transfer only if multiple data phases requested.
Target abort	Returning target abort to initiator. Set received target abort bit in target interface status register. Set signaled target abort bit in initiator interface status register.

After the PI7C7100 makes 2²⁴(default) attempts of the same delayed write transaction on the target bus, PI7C7100 asserts P_SERR# if the SERR# enable bit (bit 8 of command register for secondary bus S1 or S2) is set and the delayed-write-non-delivery bit is not set. The delayed-write-non-delivery bit is bit 5 of P_SERR# event disable register (offset 64h). PI7C7100 will report system error. See Section 7.4 for a description of system error conditions.

4.8.3.2 Posted Write Target Termination Response

When PI7C7100 initiates a posted write transaction, the target termination cannot be passed back to the initiator. Table 4–8 shows the response to each type of target termination that occurs during a posted write transaction.

Table 4-8. Responses to Posted Write Target Termination

Target Termination	Response
Normal	No additional action.
Target retry	Repeating write transaction to target.
Target disconnect	Initiate write transaction for delivering remaining posted write data.
Target abort	Set received-target-abort bit in the target interface status register. Assert P_SERR# if enabled, and set the signaled-system-error bit in primary status register.

Note that when a target retry or target disconnect is returned and posted write data associated with that transaction remains in the write buffers, PI7C7100 initiates another write transaction to attempt to deliver the rest of the write data. If there is a target retry, the exact same address will be driven as for the initial write transaction attempt. If a target disconnect is received, the address that is driven on a subsequent write transaction attempt will be updated to reflect the address of the current DWORD. If the initial write transaction is Memory-Write-and-Invalidate transaction, and a partial delivery of write data to the target is performed before a target disconnect is received, PI7C7100 will use the memory write command to deliver the rest of the write data. It is because an incomplete cache line will be transferred in the subsequent write transaction attempt.

After the PI7C7100 makes 2²⁴(default) write transaction attempts and fails to deliver all posted write data associated with that transaction, PI7C7100 asserts P_SERR# if the primary SERR# enable bit is set (bit 8 of command register for secondary bus S1 or S2) and posted-write-non-delivery bit is not set. The posted-write-non-delivery bit is the bit 2 of P_SERR# event disable register (offset 64h). PI7C7100 will report system error. See Section 7.4 for a discussion of system error conditions.

4.8.3.3 Delayed Read Target Termination Response

When PI7C7100 initiates a delayed read transaction, the abnormal target responses can be passed back to the initiator. Other target responses depend on how much data the initiator requests. Table 4–9 shows the response to each type of target termination that occurs during a delayed read transaction.

PI7C7100 repeats a delayed read transaction until one of the following conditions is met:

- PI7C7100 completes at least one data transfer.
- PI7C7100 receives a master abort.
- PI7C7100 receives a target abort.
- PI7C7100 makes 2²⁴(default) read attempts resulting in a response of target retry.

Table 4-9. Responses to Delayed Read Target Termination

Target Termination	Response
Normal	If prefetchable, target disconnect only if initiator requests more data than read from target. If non-prefetchable, target disconnect on first data phase.
Target retry	Reinitiate read transaction to target.
Target disconnect	If initiator requests more data than read from target, return target disconnect to initiator.
Target abort	Return target abort to initiator. Set received target abort bit in the target interface status register. Set signaled target abort bit in the initiator interface status register.



After PI7C7100 makes 2^{24} (default) attempts of the same delayed read transaction on the target bus, PI7C7100 asserts P_SERR# if the primary SERR# enable bit is set (bit 8 of command register for secondary bus S1 or S2) and the delayed-write-non-delivery bit is not set. The delayed-write-non-delivery bit is bit 5 of P_SERR# event disable register (offset 64h). PI7C7100 will report system error. See Section 7.4 for a description of system error conditions.

4.8.4 Target Termination Initiated by PI7C7100

PI7C7100 can return a target retry, target disconnect, or target abort to an initiator for reasons other than detection of that condition at the target interface.

4.8.4.1 Target Retry

PI7C7100 returns a target retry to the initiator when it cannot accept write data or return read data as a result of internal conditions. PI7C7100 returns a target retry to an initiator when any of the following conditions is met:

For delayed write transactions:

- The transaction is being entered into the delayed transaction queue.
- Transaction has already been entered into delayed transaction queue, but target response has not yet been received.
- Target response has been received but has not progressed to the head of the return queue.
- The delayed transaction queue is full, and the transaction cannot be queued.
- A transaction with the same address and command has been queued.
- A locked sequence is being propagated across PI7C7100, and the write transaction is not a locked transaction.
- The target bus is locked and the write transaction is a locked transaction.
- Use more than 16 clocks to accept this transaction.

For delayed read transactions:

- The transaction is being entered into the delayed transaction queue.
- The read request has already been queued, but read data is not yet available.
- Data has been read from target, but it is not yet at head of the read data queue, or a posted write transaction precedes it.
- The delayed transaction queue is full, and the transaction cannot be queued.
- A delayed read request with the same address and bus command has already been queued.
- A locked sequence is being propagated across PI7C7100, and the read transaction is not a locked transaction.
- PI7C7100 is currently discarding previously pre-fetched read data.
- The target bus is locked and the write transaction is a locked transaction.
- Use more than 16 clocks to accept this transaction.

For posted write transactions:

- The posted write data buffer does not have enough space for address and at least one DWORD of write data.
- A locked sequence is being propagated across PI7C7100, and the write transaction is not a locked transaction.

When a target retry is returned to the initiator of a delayed transaction, the initiator must repeat the transaction with the same address and bus command as well as the data if it is a write transaction, within the time frame specified by the master timeout value. Otherwise, the transaction is discarded from the buffers.

4.8.4.2 Target Disconnect

PI7C7100 returns a target disconnect to an initiator when one of the following conditions is met:

- PI7C7100 hits an internal address boundary.
- PI7C7100 cannot accept any more write data.
- PI7C7100 has no more read data to deliver.

See Section 4.5.4 for a description of write address boundaries, and Section 4.6.3 for a description of read address boundaries.

4.8.4.3 Target Abort

PI7C7100 returns a target abort to an initiator when one of the following conditions is met:

- PI7C7100 is returning a target abort from the intended target.

When PI7C7100 returns a target abort to the initiator, it sets the signaled target abort bit in the status register corresponding to the initiator interface.

4.9 Concurrent Mode Operation

The Bridge can be configured to run in concurrent operation. Concurrent operation is defined as cycles going from one device on one secondary bus to another device on the same or other secondary bus. This off-loads traffic from the primary bus, allowing other traffic to run on the primary bus concurrently.

The Bridge is already configured to handle concurrent operation. However, the devices themselves need to be configured to do so. Meaning, device drivers for the specific device used will have to be configured to perform the operation. Please contact Pericom for more information.

5. Address Decoding

PI7C7100 uses three address ranges that control I/O and memory transaction forwarding. These address ranges are defined by base and limit address registers in the configuration space. This chapter describes these address ranges, as well as ISA-mode and VGA-addressing support.

5.1 Address Ranges

PI7C7100 uses the following address ranges that determine which I/O and memory transactions are forwarded from the primary PCI bus to the secondary PCI bus, and from the secondary bus to the primary bus:

- Two 32-bit I/O address ranges
- Two 32-bit memory-mapped I/O (non-prefetchable memory) ranges
- Two 32-bit prefetchable memory address ranges

Transactions falling within these ranges are forwarded downstream from the primary PCI bus to the two secondary PCI buses. Transactions falling outside these ranges are forwarded upstream from the two secondary PCI buses to the primary PCI bus.

No address translation is required in PI7C7100. The addresses that are not marked for downstream are always forwarded upstream. However, if an address of a transaction initiated from S1 bus is located in the marked address range for downstream in S2 bus and not in the marked address range for downstream in S1 bus, the transaction will be forwarded to S2 bus instead of primary bus. By the same token, if an address of a transaction initiated from S2 bus is located in the marked address range for downstream in S1 bus and not in the marked address range for downstream in S2 bus, the transaction will be forwarded to S1 bus instead of primary bus.

5.2 I/O Address Decoding

PI7C7100 uses the following mechanisms that are defined in the configuration space to specify the I/O address space for downstream and upstream forwarding:

- I/O base and limit address registers
- The ISA enable bit
- The VGA mode bit
- The VGA snoop bit

This section provides information on the I/O address registers and ISA mode.

Section 5.4 provides information on the VGA modes.

To enable downstream forwarding of I/O transactions, the I/O enable bit must be set in the command register in configuration space. All I/O transactions initiated on the primary bus will be ignored if the I/O enable bit is not set. To enable upstream forwarding of I/O transactions, the master enable bit must be set in the command register. If the master-enable bit is not set, PI7C7100 ignores all I/O and memory transactions initiated on the secondary bus. The master-enable bit also allows upstream forwarding of memory transactions if it is set.

CAUTION

If any configuration state affecting I/O transaction forwarding is changed by a configuration write operation on the primary bus at the same time that I/O transactions are ongoing on the secondary bus, PI7C7100 response to the secondary bus I/O transactions is not predictable. Configure the I/O base and limit address registers, ISA enable bit, VGA mode bit, and VGA snoop bit before setting I/O enable and master enable bits, and change them subsequently only when the primary and secondary PCI buses are idle.

5.2.1 I/O Base and Limit Address Registers

PI7C7100 implements one set of I/O base and limit address registers in configuration space that define an I/O address range per port downstream forwarding. PI7C7100 supports 32-bit I/O addressing, which allows I/O addresses downstream of PI7C7100 to be mapped anywhere in a 4GB I/O address space.



I/O transactions with addresses that fall inside the range defined by the I/O base and limit registers are forwarded downstream from the primary PCI bus to the secondary PCI bus. I/O transactions with addresses that fall outside this range are forwarded upstream from the secondary PCI bus to the primary PCI bus.

The I/O range can be turned off by setting the I/O base address to a value greater than that of the I/O limit address. When the I/O range is turned off, all I/O transactions are forwarded upstream, and no I/O transactions are forwarded downstream. The I/O range has a minimum granularity of 4KB and is aligned on a 4KB boundary. The maximum I/O range is 4GB in size. The I/O base register consists of an 8-bit field at configuration address 1Ch, and a 16-bit field at address 30h. The top 4 bits of the 8-bit field define bits [15:12] of the I/O base address. The bottom 4 bits read only as 1h to indicate that PI7C7100 supports 32-bit I/O addressing. Bits [11:0] of the base address are assumed to be 0, which naturally aligns the base address to a 4KB boundary. The 16 bits contained in the I/O base upper 16 bits register at configuration offset 30h define AD[31:16] of the I/O base address. All 16 bits are read/write. After primary bus reset or chip reset, the value of the I/O base address is initialized to 0000 0000h.

The I/O limit register consists of an 8-bit field at configuration offset 1Dh and a 16-bit field at offset 32h. The top 4 bits of the 8-bit field define bits [15:12] of the I/O limit address. The bottom 4 bits read only as 1h to indicate that 32-bit I/O addressing is supported. Bits [11:0] of the limit address are assumed to be FFFh, which naturally aligns the limit address to the top of a 4KB I/O address block. The 16 bits contained in the I/O limit upper 16 bits register at configuration offset 32h define AD[31:16] of the I/O limit address. All 16 bits are read/write. After primary bus reset or chip reset, the value of the I/O limit address is reset to 0000 0FFFh.

Note: The initial states of the I/O base and I/O limit address registers define an I/O range of 0000 0000h to 0000 0FFFh, which is the bottom 4KB of I/O space. Write these registers with their appropriate values before setting either the I/O enable bit or the master enable bit in the command register in configuration space.

5.2.2 ISA Mode

PI7C7100 supports ISA mode by providing an ISA enable bit in the bridge control register in configuration space. ISA mode modifies the response of PI7C7100 inside the I/O address range in order to support mapping of I/O space in the presence of an ISA bus in the system. This bit only affects the response of PI7C7100 when the transaction falls inside the address range defined by the I/O base and limit address registers, and only when this address also falls inside the first 64KB of I/O space (address bits [31:16] are 0000h).

When the ISA enable bit is set, PI7C7100 does not forward downstream any I/O transactions addressing the top 768 bytes of each aligned 1KB block. Only those transactions addressing the bottom 256 bytes of an aligned 1KB block inside the base and limit I/O address range are forwarded downstream. Transactions above the 64KB I/O address boundary are forwarded as defined by the address range defined by the I/O base and limit registers.

Accordingly, if the ISA enable bit is set, PI7C7100 forwards upstream those I/O transactions addressing the top 768 bytes of each aligned 1KB block within the first 64KB of I/O space. The master enable bit in the command configuration register must also be set to enable upstream forwarding. All other I/O transactions initiated on the secondary bus are forwarded upstream only if they fall outside the I/O address range.

When the ISA enable bit is set, devices downstream of PI7C7100 can have I/O space mapped into the first 256 bytes of each 1KB chunk below the 64KB boundary, or anywhere in I/O space above the 64KB boundary.

5.3 Memory Address Decoding

PI7C7100 has three mechanisms for defining memory address ranges for forwarding of memory transactions:

- Memory-mapped I/O base and limit address registers
- Prefetchable memory base and limit address registers
- VGA mode

This section describes the first two mechanisms. Section 5.4.1 describes VGA mode.

To enable downstream forwarding of memory transactions, the memory enable bit must be set in the command register in configuration space. To enable upstream forwarding of memory transactions, the master-enable bit must be set in the command register. The master-enable bit also allows upstream forwarding of I/O transactions if it is set.

CAUTION

If any configuration state affecting memory transaction forwarding is changed by a configuration write operation on the primary bus at the same time that memory transactions are ongoing on the secondary bus, response to the secondary bus memory transactions is not predictable. Configure the memory-mapped I/O base and limit address registers, prefetchable memory base and limit address registers, and VGA mode bit before setting the memory enable and master enable bits, and change them subsequently only when the primary and secondary PCI buses are idle.

5.3.1 Memory-Mapped I/O Base and Limit Address Registers

Memory-mapped I/O is also referred to as non-prefetchable memory. Memory addresses that cannot automatically be pre-fetched but that can be conditionally pre-fetched based on command type should be mapped into this space. Read transactions to non-prefetchable space may exhibit side effects; this space may have non-memory-like behavior. PI7C7100 pre-fetches in this space only if the memory read line or memory read multiple commands are used; transactions using the memory read command are limited to a single data transfer.

The memory-mapped I/O base address and memory-mapped I/O limit address registers define an address range that PI7C7100 uses to determine when to forward memory commands. PI7C7100 forwards a memory transaction from the primary to the secondary interface if the transaction address falls within the memory-mapped I/O address range. PI7C7100 ignores memory transactions initiated on the secondary interface that fall into this address range. Any transactions that fall outside this address range are ignored on the primary interface and are forwarded upstream from the secondary interface (provided that they do not fall into the prefetchable memory range or are not forwarded downstream by the VGA mechanism).

The memory-mapped I/O range supports 32-bit addressing only. The PCI-to-PCI Bridge Architecture Specification does not provide for 64-bit addressing in the memory-mapped I/O space. The memory-mapped I/O address range has a granularity and alignment of 1MB. The maximum memory-mapped I/O address range is 4GB.

The memory-mapped I/O address range is defined by a 16-bit memory-mapped I/O base address register at configuration offset 20h and by a 16-bit memory-mapped I/O limit address register at offset 22h. The top 12 bits of each of these registers correspond to bits [31:20] of the memory address. The low 4 bits are hardwired to 0. The lowest 20 bits of the memory-mapped I/O base address are assumed to be 0 0000h, which results in a natural alignment to a 1MB boundary. The lowest 20 bits of the memory-mapped I/O limit address are assumed to be F FFFFh, which results in an alignment to the top of a 1MB block.

Note: The initial state of the memory-mapped I/O base address register is 0000 0000h. The initial state of the memory-mapped I/O limit address register is 000F FFFFh. Note that the initial states of these registers define a memory-mapped I/O range at the bottom 1MB block of memory. Write these registers with their appropriate values before setting either the memory enable bit or the master enable bit in the command register in configuration space.

To turn off the memory-mapped I/O address range, write the memory-mapped I/O base address register with a value greater than that of the memory-mapped I/O limit address register.

5.3.2 Prefetchable Memory Base and Limit Address Registers

Locations accessed in the prefetchable memory address range must have true memory-like behavior and must not exhibit side effects when read. This means that extra reads to a prefetchable memory location must have no side effects. PI7C7100 pre-fetches for all types of memory read commands in this address space.

The prefetchable memory base address and prefetchable memory limit address registers define an address range that PI7C7100 uses to determine when to forward memory commands. PI7C7100 forwards a memory transaction from the primary to the secondary interface if the transaction address falls within the prefetchable memory address range. PI7C7100 ignores memory transactions initiated on the secondary interface that fall into this address range. PI7C7100 does not respond to any transactions that fall outside this address range on the primary interface and forwards those transactions upstream from the secondary interface (provided that they do not fall into the memory-mapped I/O range or are not forwarded by the VGA mechanism).

The prefetchable memory range supports 64-bit addressing and provides additional registers to define the upper 32 bits of the memory address range, the prefetchable memory base address upper 32 bits register, and the prefetchable memory limit address upper 32 bits register. For address comparison, a single address cycle (32-bit address) prefetchable memory transaction is treated like a 64-bit address transaction where the upper 32 bits of the address are equal to 0. This upper



32-bit value of 0 is compared to the prefetchable memory base address upper 32 bits register and the prefetchable memory limit address upper 32 bits register. The prefetchable memory base address upper 32 bits register must be 0 to pass any single address cycle transactions downstream.

Prefetchable memory address range has a granularity and alignment of 1MB. Maximum memory address range is 4GB when 32-bit addressing is being used.

Prefetchable memory address range is defined by a 16-bit prefetchable memory base address register at configuration offset 24h and by a 16-bit prefetchable memory limit address register at offset 26h. The top 12 bits of each of these registers correspond to bits [31:20] of the memory address. The lowest 4 bits are hardwired to 1h. The lowest 20 bits of the prefetchable memory base address are assumed to be 0 0000h, which results in a natural alignment to a 1MB boundary. The lowest 20 bits of the prefetchable memory limit address are assumed to be FFFFh, which results in an alignment to the top of a 1MB block.

Note: The initial state of the prefetchable memory base address register is 0000 0000h. The initial state of the prefetchable memory limit address register is 000F FFFFh. Note that the initial states of these registers define a prefetchable memory range at the bottom 1MB block of memory. Write these registers with their appropriate values before setting either the memory enable bit or the master enable bit in the command register in configuration space.

To turn off the prefetchable memory address range, write the prefetchable memory base address register with a value greater than that of the prefetchable memory limit address register. The entire base value must be greater than the entire limit value, meaning that the upper 32 bits must be considered. Therefore, to disable the address range, the upper 32 bits registers can both be set to the same value, while the lower base register is set greater than the lower limit register. Otherwise, the upper 32-bit base must be greater than the upper 32-bit limit.

5.4 VGA Support

PI7C7100 provides two modes for VGA support:

- VGA mode, supporting VGA-compatible addressing
- VGA snoop mode, supporting VGA palette forwarding

5.4.1 VGA Mode

When a VGA-compatible device exists downstream from PI7C7100, set the VGA mode bit in the bridge control register in configuration space to enable VGA mode. When PI7C7100 is operating in VGA mode, it forwards downstream those transactions addressing the VGA frame buffer memory and VGA I/O registers, regardless of the values of the base and limit address registers. PI7C7100 ignores transactions initiated on the secondary interface addressing these locations.

The VGA frame buffer consists of the following memory address range:

000A 0000h–000B FFFFh

Read transactions to frame buffer memory are treated as non-prefetchable. PI7C7100 requests only a single data transfer from the target, and read byte enable bits are forwarded to the target bus.

The VGA I/O addresses are in the range of 3B0h–3BBh and 3C0h–3DFh I/O. These I/O addresses are aliases every 1KB throughout the first 64KB of I/O space. This means that address bits <15:10> are not decoded and can be any value, while address bits [31:16] must be all 0s. VGA BIOS addresses starting at C0000h are not decoded in VGA mode.

5.4.2 VGA Snoop Mode

PI7C7100 provides VGA snoop mode, allowing for VGA palette write transactions to be forwarded downstream. This mode is used when a graphics device downstream from PI7C7100 needs to snoop or respond to VGA palette write transactions. To enable the mode, set the VGA snoop bit in the command register in configuration space. Note that PI7C7100 claims VGA palette write transactions by asserting DEVSEL# in VGA snoop mode.

When VGA snoop bit is set, PI7C7100 forwards downstream transactions within the 3C6h, 3C8h and 3C9h I/O addresses space. Note that these addresses are also forwarded as part of the VGA compatibility mode previously described. Again, address bits <15:10> are not decoded, while address bits <31:16> must be equal to 0, which means that these addresses are aliases every 1KB throughout the first 64KB of I/O space.

Note: If both the VGA mode bit and the VGA snoop bit are set, PI7C7100 behaves in the same way as if only the VGA mode bit were set.

6. Transaction Ordering

To maintain data coherency and consistency, PI7C7100 complies with the ordering rules set forth in the PCI Local Bus Specification, Revision 2.1, for transactions crossing the bridge. This chapter describes the ordering rules that control transaction forwarding across PI7C7100.

6.1 Transactions Governed by Ordering Rules

Ordering relationships are established for the following classes of transactions crossing PI7C7100:

- **Posted write transactions, comprised of memory write and memory write and invalidate transactions.**
Posted write transactions complete at the source before they complete at the destination; that is, data is written into intermediate data buffers before it reaches the target.
- **Delayed write request transactions, comprised of I/O write and configuration write transactions.**
Delayed write requests are terminated by target retry on the initiator bus and are queued in the delayed transaction queue. A delayed write transaction must complete on the target bus before it completes on the initiator bus.
- **Delayed write completion transactions, comprised of I/O write and configuration write transactions.**
Delayed write completion transactions complete on the target bus, and the target response is queued in the buffers. A delayed write completion transaction proceeds in the direction opposite that of the original delayed write request; that is, a delayed write completion transaction proceeds from the target bus to the initiator bus.
- **Delayed read request transactions, comprised of all memory read, I/O read, and configuration read transactions.**
Delayed read requests are terminated by target retry on the initiator bus and are queued in the delayed transaction queue.
- **Delayed read completion transactions, comprised of all memory read, I/O read, & configuration read transactions.**
Delayed read completion transactions complete on the target bus, and the read data is queued in the read data buffers. A delayed read completion transaction proceeds in the direction opposite that of the original delayed read request; that is, a delayed read completion transaction proceeds from the target bus to the initiator bus.

PI7C7100 does not combine or merge write transactions:

- PI7C7100 does not combine separate write transactions into a single write transaction—this optimization is best implemented in the originating master.
- PI7C7100 does not merge bytes on separate masked write transactions to the same DWORD address—this optimization is also best implemented in the originating master.
- PI7C7100 does not collapse sequential write transactions to the same address into a single write transaction—the PCI Local Bus Specification does not permit this combining of transactions.

6.2 General Ordering Guidelines

Independent transactions on primary and secondary buses have a relationship only when those transactions cross PI7C7100.

The following general ordering guidelines govern transactions crossing PI7C7100:

- The ordering relationship of a transaction with respect to other transactions is determined when the transaction completes, that is, when a transaction ends with a termination other than target retry.
- Requests terminated with target retry can be accepted and completed in any order with respect to other transactions that have been terminated with target retry. If the order of completion of delayed requests is important, the initiator should not start a second delayed transaction until the first one has been completed. If more than one delayed transaction is initiated, the initiator should repeat all delayed transaction requests, using some fairness algorithm. Repeating a delayed transaction cannot be contingent on completion of another delayed transaction. Otherwise, a deadlock can occur.



- Write transactions flowing in one direction have no ordering requirements with respect to write transactions flowing in the other direction. PI7C7100 can accept posted write transactions on both interfaces at the same time, as well as initiate posted write transactions on both interfaces at the same time.
- The acceptance of a posted memory write transaction as a target can never be contingent on the completion of a non-locked, non-posted transaction as a master. This is true for PI7C7100 and must also be true for other bus agents. Otherwise, a deadlock can occur.
- PI7C7100 accepts posted write transactions, regardless of the state of completion of any delayed transactions being forwarded across PI7C7100.

6.3 Ordering Rules

Table 6–1 shows the ordering relationships of all the transactions and refers by number to the ordering rules that follow.

Table 6-1. Summary of Transaction Ordering

Pass	Posted Write	Delayed Read Request	Delayed Write Request	Delayed Read Completion	Delayed Write Completion
Posted write	N ¹	Y ⁵	Y ⁵	Y ⁵	Y ⁵
Delayed read request	N ²	N	N	Y	Y
Delayed write request	N ⁴	N	N	Y	Y
Delayed read completion	N ³	Y	Y	N	N
Delayed write completion	Y	Y	Y	N	N

Note: The superscript accompanying some of the table entries refers to any applicable ordering rule listed in this section. Many entries are not governed by these ordering rules; therefore, the implementation can choose whether or not the transactions pass each other.

The entries without superscripts reflect the PI7C7100's implementation choices.

The following ordering rules describe the transaction relationships. Each ordering rule is followed by an explanation, and the ordering rules are referred to by number in Table 6–1. These ordering rules apply to posted write transactions, delayed write and read requests, and delayed write and read completion transactions crossing PI7C7100 in the same direction. Note that delayed completion transactions cross PI7C7100 in the direction opposite that of the corresponding delayed requests.

1. Posted write transactions must complete on the target bus in the order in which they were received on the initiator bus. The subsequent posted write transaction can be setting a flag that covers the data in the first posted write transaction; if the second transaction were to complete before the first transaction, a device checking the flag could subsequently consume stale data.
2. A delayed read request traveling in the same direction as a previously queued posted write transaction must push the posted write data ahead of it. The posted write transaction must complete on the target bus before the delayed read request can be attempted on the target bus. The read transaction can be to the same location as the write data, so if the read transaction were to pass the write transaction, it would return stale data.
3. A delayed read completion must “pull” ahead of previously queued posted write data traveling in the same direction. In this case, the read data is traveling in the same direction as the write data, and the initiator of the read transaction is on the same side of PI7C7100 as the target of the write transaction. The posted write transaction must complete to the target before the read data is returned to the initiator. The read transaction can be a reading to a status register of the initiator of the posted write data and therefore should not complete until the write transaction is complete.
4. Delayed write requests cannot pass previously queued posted write data. For posted memory write transactions, the delayed write transaction can set a flag that covers the data in the posted write transaction. If the delayed write request were to complete before the earlier posted write transaction, a device checking the flag could subsequently consume stale data.



5. Posted write transactions must be given opportunities to pass delayed read and write requests and completions. Otherwise, deadlocks may occur when some bridges which support delayed transactions and other bridges which do not support delayed transactions are being used in the same system. A fairness algorithm is used to arbitrate between the posted write queue and the delayed transaction queue.

6.4 Data Synchronization

Data synchronization refers to the relationship between interrupt signaling and data delivery. The PCI Local Bus Specification, Revision 2.1, provides the following alternative methods for synchronizing data and interrupts:

- The device signaling the interrupt performs a read of the data just written (software).
- The device driver performs a read operation to any register in the interrupting device before accessing data written by the device (software).
- System hardware guarantees that write buffers are flushed before interrupts are forwarded.

PI7C7100 does not have a hardware mechanism to guarantee data synchronization for posted write transactions. Therefore, all posted write transactions must be followed by a read operation, either from the device to the location just written (or some other location along the same path), or from the device driver to one of the device registers.

7. Error Handling

PI7C7100 checks, forwards, and generates parity on both the primary and secondary interfaces. To maintain transparency, PI7C7100 always tries to forward the existing parity condition on one bus to the other bus, along with address and data. PI7C7100 always attempts to be transparent when reporting errors, but this is not always possible, given the presence of posted data and delayed transactions.

To support error reporting on the PCI bus, PI7C7100 implements the following:

- PERR# and SERR# signals on both the primary and secondary interfaces
- Primary status and secondary status registers
- The device-specific P_SERR# event disable register

This chapter provides detailed information about how PI7C7100 handles errors. It also describes error status reporting and error operation disabling.

7.1 Address Parity Errors

PI7C7100 checks address parity for all transactions on both buses, for all address and all bus commands. When PI7C7100 detects an address parity error on the primary interface, the following events occur:

- If the parity error response bit is set in the command register, PI7C7100 does not claim the transaction with P_DEVSEL#; this may allow the transaction to terminate in a master abort. If parity error response bit is not set, PI7C7100 proceeds normally and accepts the transaction if it is directed to or across PI7C7100.
- PI7C7100 sets the detected parity error bit in the status register.
- PI7C7100 asserts P_SERR# and sets signaled system error bit in the status register, if both the following conditions are met:
 - The SERR# enable bit is set in the command register.
 - The parity error response bit is set in the command register.

When PI7C7100 detects an address parity error on the secondary interface, the following events occur:

- If the parity error response bit is set in the bridge control register, PI7C7100 does not claim the transaction with S1_DEVSEL# or S2_DEVSEL#; this may allow the transaction to terminate in a master abort. If parity error response bit is not set, PI7C7100 proceeds normally and accepts transaction if it is directed to or across PI7C7100.
- PI7C7100 sets the detected parity error bit in the secondary status register.
- PI7C7100 asserts P_SERR# and sets signaled system error bit in status register, if both of the following conditions are met:
 - The SERR# enable bit is set in the command register.
 - The parity error response bit is set in the bridge control register.

7.2 Data Parity Errors

When forwarding transactions, PI7C7100 attempts to pass the data parity condition from one interface to the other unchanged, whenever possible, to allow the master and target devices to handle the error condition.

The following sections describe, for each type of transaction, the sequence of events that occurs when a parity error is detected and the way in which the parity condition is forwarded across PI7C7100.

7.2.1 Configuration Write Transactions to Configuration Space

When PI7C7100 detects a data parity error during a Type 0 configuration write transaction to PI7C7100 configuration space, the following events occur:

- If the parity error response bit is set in the command register, PI7C7100 asserts P_TRDY# and writes the data to the configuration register. PI7C7100 also asserts P_PERR#. If the parity error response bit is not set, PI7C7100 does not assert P_PERR#.
- PI7C7100 sets the detected parity error bit in the status register, regardless of the state of the parity error response bit.



7.2.2 Read Transactions

When PI7C7100 detects a parity error during a read transaction, the target drives data and data parity, and the initiator checks parity and conditionally asserts PERR#.

For downstream transactions, when PI7C7100 detects a read data parity error on the secondary bus, the following events occur:

- PI7C7100 asserts S_PERR# two cycles following the data transfer, if the secondary interface parity error response bit is set in the bridge control register.
- PI7C7100 sets the detected parity error bit in the secondary status register.
- PI7C7100 sets the data parity detected bit in the secondary status register, if the secondary interface parity error response bit is set in the bridge control register.
- PI7C7100 forwards the bad parity with the data back to the initiator on the primary bus.
If the data with the bad parity is pre-fetched and is not read by the initiator on the primary bus, the data is discarded and the data with bad parity is not returned to the initiator.
- PI7C7100 completes the transaction normally.

For upstream transactions, when PI7C7100 detects a read data parity error on the primary bus, the following events occur:

- PI7C7100 asserts P_PERR# two cycles following the data transfer, if the primary interface parity error response bit is set in the command register.
- PI7C7100 sets the detected parity error bit in the primary status register.
- PI7C7100 sets the data parity detected bit in the primary status register, if the primary interface parity-error-response bit is set in the command register.
- PI7C7100 forwards the bad parity with the data back to the initiator on the secondary bus.
If the data with the bad parity is pre-fetched and is not read by the initiator on the secondary bus, the data is discarded and the data with bad parity is not returned to the initiator.
- PI7C7100 completes the transaction normally.
PI7C7100 returns to the initiator the data and parity that was received from the target. When the initiator detects a parity error on this read data and is enabled to report it, the initiator asserts PERR# two cycles after the data transfer occurs. It is assumed that the initiator takes responsibility for handling a parity error condition; therefore, when PI7C7100 detects PERR# asserted while returning read data to the initiator, PI7C7100 does not take any further action and completes the transaction normally.

7.2.3 Delayed Write Transactions

When PI7C7100 detects a data parity error during a delayed write transaction, the initiator drives data and data parity, and the target checks parity and conditionally asserts PERR#.

For delayed write transactions, a parity error can occur at the following times:

- During the original delayed write request transaction
- When the initiator repeats the delayed write request transaction
- When PI7C7100 completes the delayed write transaction to the target

When a delayed write transaction is normally queued, the address, command, address parity, data, byte enable bits, and data parity are all captured and a target retry is returned to the initiator. When PI7C7100 detects a parity error on the write data for the initial delayed write request transaction, the following events occur:

- If the parity-error-response bit corresponding to the initiator bus is set, PI7C7100 asserts TRDY# to the initiator and the transaction is not queued. If multiple data phases are requested, STOP# is also asserted to cause a target disconnect. Two cycles after the data transfer, PI7C7100 also asserts PERR#.
If the parity-error-response bit is not set, PI7C7100 returns a target retry. It queues the transaction as usual. PI7C7100 does not assert PERR#. In this case, the initiator repeats the transaction.
- PI7C7100 sets the detected-parity-error bit in the status register corresponding to the initiator bus, regardless of the state of the parity-error-response bit.



Note: If parity checking is turned off and data parity errors have occurred for queued or subsequent delayed write transactions on the initiator bus, it is possible that the initiator's re-attempts of the write transaction may not match the original queued delayed write information contained in the delayed transaction queue. In this case, a master timeout condition may occur, possibly resulting in a system error (P_SERR# assertion).

For downstream transactions, when PI7C7100 is delivering data to the target on the secondary bus and S_PERR# is asserted by the target, the following events occur:

- PI7C7100 sets the secondary interface data parity detected bit in the secondary status register, if the secondary parity error response bit is set in the bridge control register.
- PI7C7100 captures the parity error condition to forward it back to the initiator on the primary bus.

Similarly, for upstream transactions, when PI7C7100 is delivering data to the target on the primary bus and P_PERR# is asserted by the target, the following events occur:

- PI7C7100 sets the primary interface data-parity-detected bit in the status register, if the primary parity-error-response bit is set in the command register.
- PI7C7100 captures the parity error condition to forward it back to the initiator on the secondary bus.

A delayed write transaction is completed on the initiator bus when the initiator repeats the write transaction with the same address, command, data, and byte enable bits as the delayed write command that is at the head of the posted data queue. Note that the parity bit is not compared when determining whether the transaction matches those in the delayed transaction queues.

Two cases must be considered:

- When parity error is detected on the initiator bus on a subsequent re-attempt of the transaction and was not detected on the target bus
- When parity error is forwarded back from the target bus

For downstream delayed write transactions, when the parity error is detected on the initiator bus and PI7C7100 has write status to return, the following events occur:

- PI7C7100 first asserts P_TRDY# and then asserts P_PERR# two cycles later, if the primary interface parity-error-response bit is set in the command register.
- PI7C7100 sets the primary interface parity-error-detected bit in the status register.
- Because there was not an exact data and parity match, the write status is not returned and the transaction remains in the queue.

Similarly, for upstream delayed write transactions, when the parity error is detected on the initiator bus and PI7C7100 has write status to return, the following events occur:

- PI7C7100 first asserts S1_TRDY# or S2_TRDY# and then asserts S_PERR# two cycles later, if the secondary interface parity-error-response bit is set in the bridge control register (offset 3Ch).
- PI7C7100 sets the secondary interface parity-error-detected bit in the secondary status register.
- Because there was not an exact data and parity match, the write status is not returned and the transaction remains in the queue.

For downstream transactions, where the parity error is being passed back from the target bus and the parity error condition was not originally detected on the initiator bus, the following events occur:

- PI7C7100 asserts P_PERR# two cycles after the data transfer, if the following are both true:
 - The parity-error-response bit is set in the command register of the primary interface.
 - The parity-error-response bit is set in the bridge control register of the secondary interface.
- PI7C7100 completes the transaction normally.

For upstream transactions, when the parity error is being passed back from the target bus and the parity error condition was not originally detected on the initiator bus, the following events occur:

- PI7C7100 asserts S_PERR# two cycles after the data transfer, if the following are both true:
 - The parity error response bit is set in the command register of the primary interface.
 - The parity error response bit is set in the bridge control register of the secondary interface.
- PI7C7100 completes the transaction normally.

7.2.4 Posted Write Transactions

During downstream posted write transactions, when PI7C7100 responds as a target, it detects a data parity error on the initiator (primary) bus, the following events occur:

- PI7C7100 asserts P_PERR# two cycles after the data transfer, if the parity error response bit is set in the command register of primary interface.
- PI7C7100 sets the parity error detected bit in the status register of the primary interface.
- PI7C7100 captures and forwards the bad parity condition to the secondary bus.
- PI7C7100 completes the transaction normally.

Similarly, during upstream posted write transactions, when PI7C7100 responds as a target, it detects a data parity error on the initiator (secondary) bus, the following events occur:

- PI7C7100 asserts S_PERR# two cycles after the data transfer, if the parity error response bit is set in the bridge control register of the secondary interface.
- PI7C7100 sets the parity error detected bit in the status register of the secondary interface.
- PI7C7100 captures and forwards the bad parity condition to the primary bus.
- PI7C7100 completes the transaction normally.

During downstream write transactions, when a data parity error is reported on the target (secondary) bus by the target's assertion of S_PERR#, the following events occur:

- PI7C7100 sets the data parity detected bit in the status register of secondary interface, if the parity error response bit is set in the bridge control register of the secondary interface.
- PI7C7100 asserts P_SERR# and sets the signaled system error bit in the status register, if all the following conditions are met:
 - The SERR# enable bit is set in the command register.
 - The posted write parity error bit of P_SERR# event disable register is not set.
 - The parity error response bit is set in the bridge control register of the secondary interface.
 - The parity error response bit is set in the command register of the primary interface.
 - PI7C7100 has not detected the parity error on the primary (initiator) bus which the parity error is not forwarded from the primary bus to the secondary bus.

During upstream write transactions, when a data parity error is reported on the target (primary) bus by the target's assertion of P_PERR#, the following events occur:

- PI7C7100 sets the data parity detected bit in the status register, if the parity error response bit is set in the command register of the primary interface.
- PI7C7100 asserts P_SERR# and sets the signaled system error bit in the status register, if all the following conditions are met:
 - The SERR# enable bit is set in the command register.
 - The parity error response bit is set in the bridge control register of the secondary interface.
 - The parity error response bit is set in the command register of the primary interface.
 - PI7C7100 has not detected the parity error on the secondary (initiator) bus which the parity error is not forwarded from the secondary bus to the primary bus.

Assertion of P_SERR# is used to signal the parity error condition when the initiator does not know that the error occurred.



Because the data has already been delivered with no errors, there is no other way to signal this information back to the initiator.

If the parity error has forwarded from the initiating bus to the target bus, P_SERR# will not be asserted.

7.3 Data Parity Error Reporting Summary

In the previous sections, the responses of PI7C7100 to data parity errors are presented according to the type of transaction in progress. This section organizes the responses of PI7C7100 to data parity errors according to the status bits that PI7C7100 sets and the signals that it asserts.

Table 7–1 shows setting the detected parity error bit in the status register, corresponding to the primary interface. This bit is set when PI7C7100 detects a parity error on the primary interface.

Table 7–1 Setting the Primary Interface Detected Parity Error Bit

Primary detected parity error bit	Transaction Type	Direction	Bus where error was detected	Primary/Secondary parity error response bits
0	Read	Downstream	Primary	x/x ¹
0	Read	Downstream	Secondary	x/x
1	Read	Upstream	Primary	x/x
0	Read	Upstream	Secondary	x/x
1	Posted write	Downstream	Primary	x/x
0	Posted write	Downstream	Secondary	x/x
0	Posted write	Upstream	Primary	x/x
0	Posted write	Upstream	Secondary	x/x
1	Delayed write	Downstream	Primary	x/x
0	Delayed write	Downstream	Secondary	x/x
0	Delayed write	Upstream	Primary	x/x
0	Delayed write	Upstream	Secondary	x/x

¹x =don't care

Table 7–2 shows setting the detected parity error bit in the secondary status register, corresponding to the secondary interface. This bit is set when PI7C7100 detects a parity error on the secondary interface.

Table 7–2. Setting Secondary Interface Detected Parity Error Bit

Secondary detected parity error bit	Transaction Type	Direction	Bus where error was detected	Primary/Secondary parity error response bits
0	Read	Downstream	Primary	x/x ¹
1	Read	Downstream	Secondary	x/x
0	Read	Upstream	Primary	x/x
0	Read	Upstream	Secondary	x/x
0	Posted write	Downstream	Primary	x/x
0	Posted write	Downstream	Secondary	x/x
0	Posted write	Upstream	Primary	x/x
1	Posted write	Upstream	Secondary	x/x
0	Delayed write	Downstream	Primary	x/x
0	Delayed write	Downstream	Secondary	x/x
0	Delayed write	Upstream	Primary	x/x
1	Delayed write	Upstream	Secondary	x/x

Table 7–3 shows setting data parity detected bit in the primary interface’s status register. This bit is set under the following conditions:

- PI7C7100 must be a master on the primary bus.
- The parity error response bit in the command register, corresponding to the primary interface, must be set.
- The P_PERR# signal is detected asserted or a parity error is detected on the primary bus.

Table 7–3. Setting Primary Interface Data Parity Detected Bit

Primary data parity bit	Transaction Type	Direction	Bus where error was detected	Primary/Secondary parity error response bits
0	Read	Downstream	Primary	x/x ¹
0	Read	Downstream	Secondary	x/x
1	Read	Upstream	Primary	1/x
0	Read	Upstream	Secondary	x/x
0	Posted write	Downstream	Primary	x/x
0	Posted write	Downstream	Secondary	x/x
1	Posted write	Upstream	Primary	1/x
0	Posted write	Upstream	Secondary	x/x
0	Delayed write	Downstream	Primary	x/x
0	Delayed write	Downstream	Secondary	x/x
1	Delayed write	Upstream	Primary	1/x
0	Delayed write	Upstream	Secondary	x/x

¹x =don't care



Table 7–4 shows setting the data parity detected bit in the status register of secondary interface. This bit is set under the following conditions:

- The PI7C7100 must be a master on the secondary bus.
- The parity error response bit must be set in the bridge control register of secondary interface.
- The S_PERR# signal is detected asserted or a parity error is detected on the secondary bus.

Table 7–4. Setting Secondary Interface Data Parity Detected Bit

Secondary data parity detected bit	Transaction Type	Direction	Bus where error was detected	Primary/Secondary parity error response bits
0	Read	Downstream	Primary	x/x ¹
1	Read	Downstream	Secondary	x/1
0	Read	Upstream	Primary	x/x
0	Read	Upstream	Secondary	x/x
0	Posted write	Downstream	Primary	x/x
1	Posted write	Downstream	Secondary	x/1
0	Posted write	Upstream	Primary	x/x
0	Posted write	Upstream	Secondary	x/x
0	Delayed write	Downstream	Primary	x/x
1	Delayed write	Downstream	Secondary	x/1
0	Delayed write	Upstream	Primary	x/x
0	Delayed write	Upstream	Secondary	x/x

¹x =don't care



Table 7–5 shows assertion of P_PERR#. This signal is set under the following conditions:

- PI7C7100 is either the target of a write transaction or the initiator of a read transaction on the primary bus.
- The parity-error-response bit must be set in the command register of primary interface.
- PI7C7100 detects a data parity error on the primary bus or detects S_PERR# asserted during the completion phase of a downstream delayed write transaction on the target (secondary) bus.

Table 7–5. Assertion of P_PERR#

P_PERR#	Transaction Type	Direction	Bus where error was detected	Primary/Secondary parity error response bits
1 (de-asserted)	Read	Downstream	Primary	x/x ¹
1	Read	Downstream	Secondary	x/x
0 (asserted)	Read	Upstream	Primary	1/x
1	Read	Upstream	Secondary	x/x
0	Posted write	Downstream	Primary	1/x
1	Posted write	Downstream	Secondary	x/x
1	Posted write	Upstream	Primary	x/x
1	Posted write	Upstream	Secondary	x/x
0	Delayed write	Downstream	Primary	1/x
0 ²	Delayed write	Downstream	Secondary	1/1
1	Delayed write	Upstream	Primary	x/x
1	Delayed write	Upstream	Secondary	x/x

¹x =don't care

²The parity error was detected on the target (secondary) bus but not on the initiator (primary) bus.



ADVANCE INFORMATION

**PI7C7100
3-Port PCI Bridge**

Table 7–6 shows assertion of S_PERR# that is set under the following conditions:

- PI7C7100 is either the target of a write transaction or the initiator of a read transaction on the secondary bus.
- The parity error response bit must be set in the bridge control register of secondary interface.
- PI7C7100 detects a data parity error on the secondary bus or detects P_PERR# asserted during the completion phase of an upstream delayed write transaction on the target (primary) bus.

Table 7–6. Assertion of S_PERR#

S_PERR#	Transaction Type	Direction	Bus where error was detected	Primary/Secondary parity error response bits
1 (de-asserted)	Read	Downstream	Primary	x/x ¹
0 (asserted)	Read	Downstream	Secondary	x/1
1	Read	Upstream	Primary	x/x
1	Read	Upstream	Secondary	x/x
1	Posted write	Downstream	Primary	x/x
1	Posted write	Downstream	Secondary	x/x
1	Posted write	Upstream	Primary	x/x
0	Posted write	Upstream	Secondary	x/1
1	Delayed write	Downstream	Primary	x/x
1	Delayed write	Downstream	Secondary	x/x
0 ²	Delayed write	Upstream	Primary	1/1
0	Delayed write	Upstream	Secondary	x/1

¹x =don't care

²The parity error was detected on the target (secondary) bus but not on the initiator (primary) bus.



Table 7–7 shows assertion of P_SERR#. This signal is set under the following conditions:

- PI7C7100 has detected P_PERR# asserted on an upstream posted write transaction or S_PERR# asserted on a downstream posted write transaction.
- PI7C7100 did not detect the parity error as a target of the posted write transaction.
- The parity error response bit on the command register and the parity error response bit on the bridge control register must both be set.
- The SERR# enable bit must be set in the command register.

Table 7–7. Assertion of P_SERR# for Data Parity Errors

P_SERR#	Transaction Type	Direction	Bus where error was detected	Primary/Secondary parity error response bits
1 (de-asserted)	Read	Downstream	Primary	x/x ¹
1	Read	Downstream	Secondary	x/x
1	Read	Upstream	Primary	x/x
1	Read	Upstream	Secondary	x/x
1	Posted write	Downstream	Primary	x/x
0 ² (asserted)	Posted write	Downstream	Secondary	1/1
0 ³	Posted write	Upstream	Primary	1/1
1	Posted write	Upstream	Secondary	x/x
1	Delayed write	Downstream	Primary	x/x
1	Delayed write	Downstream	Secondary	x/x
1	Delayed write	Upstream	Primary	x/x
1	Delayed write	Upstream	Secondary	x/x

¹x =don't care

²The parity error was detected on the target (secondary) bus but not on the initiator (primary) bus.

³The parity error was detected on the target (primary) bus but not on the initiator (secondary) bus.



7.4 System Error (SERR#) Reporting

PI7C7100 uses the P_SERR# signal to report conditionally a number of system error conditions in addition to the special case parity error conditions described in Section 7.2.3.

Whenever assertion of P_SERR# is discussed in this document, it is assumed that the following conditions apply:

- For PI7C7100 to assert P_SERR# for any reason, the SERR# enable bit must be set in the command register.
- Whenever PI7C7100 asserts P_SERR#, PI7C7100 must also set the signaled system error bit in the status register.

In compliance with the PCI-to-PCI Bridge Architecture Specification, PI7C7100 asserts P_SERR# when it detects the secondary SERR# input, S_SERR#, asserted and the SERR# forward enable bit is set in the bridge control register. In addition, PI7C7100 also sets the received system error bit in the secondary status register.

PI7C7100 also conditionally asserts P_SERR# for any of the following reasons:

- Target abort detected during posted write transaction
- Master abort detected during posted write transaction
- Posted write data discarded after 2^{24} (default) attempts to deliver (2^{24} target retries received)
- Parity error reported on target bus during posted write transaction (see previous section)
- Delayed write data discarded after 2^{24} (default) attempts to deliver (2^{24} target retries received)
- Delayed read data cannot be transferred from target after 2^{24} (default) attempts (2^{24} target retries received)
- Master timeout on delayed transaction

The device-specific P_SERR# status register reports the reason for the assertion of P_SERR#.

Most of these events have additional device-specific disable bits in the P_SERR# event disable register that make it possible to mask out P_SERR# assertion for specific events. The master timeout condition has a SERR# enable bit for that event in the bridge control register and therefore does not have a device-specific disable bit.

8. Exclusive Access

This chapter describes the use of the LOCK# signal to implement exclusive access to a target for transactions that cross PI7C7100.

8.1 Concurrent Locks

The primary and secondary bus lock mechanisms operate concurrently except when a locked transaction crosses PI7C7100. A primary master can lock a primary target without affecting the status of the lock on the secondary bus, and vice versa. This means that a primary master can lock a primary target at the same time that a secondary master locks a secondary target.

8.2 Acquiring Exclusive Access across PI7C7100

For any PCI bus, before acquiring access to the LOCK# signal and starting a series of locked transactions, the initiator must first check that both of the following conditions are met:

- The PCI bus must be idle.
- The LOCK# signal must be de-asserted.

The initiator leaves the LOCK# signal de-asserted during the address phase and asserts LOCK# one clock cycle later. Once a data transfer is completed from the target, the target lock has been achieved.

Locked transactions can cross PI7C7100 in the downstream and upstream directions, from the primary bus to the secondary bus and vice versa.

When the target resides on another PCI bus, the master must acquire not only the lock on its own PCI bus but also the lock on every bus between its bus and the target's bus. When PI7C7100 detects on the primary bus, an initial locked transaction intended for a target on the secondary bus, PI7C7100 samples the address, transaction type, byte enable bits, and parity, as described in Section 4.6.4. It also samples the lock signal. If there is a lock established between 2 ports or the target bus is already locked by another master, then the current lock cycle is retried without forward. Because a target retry is signaled to the initiator, the initiator must relinquish the lock on the primary bus, and therefore the lock is not yet established.

The first locked transaction must be a read transaction. Subsequent locked transactions can be read or write transactions. Posted memory write transactions that are a part of the locked transaction sequence are still posted. Memory read transactions that are a part of the locked transaction sequence are not pre-fetched.

When the locked delayed read request is queued, PI7C7100 does not queue any more transactions until the locked sequence is finished. PI7C7100 signals a target retry to all transactions initiated subsequent to the locked read transaction that are intended for targets on the other side of PI7C7100. PI7C7100 allows any transactions queued before the locked transaction to complete before initiating the locked transaction.

When the locked delayed read request transaction moves to the head of the delayed transaction queue, PI7C7100 initiates the transaction as a locked read transaction by de-asserting LOCK# on the target bus during the first address phase, and by asserting LOCK# one cycle later. If LOCK# is already asserted (used by another initiator), PI7C7100 waits to request access to the secondary bus until LOCK# is de-asserted when the target bus is idle. Note that the existing lock on the target bus could not have crossed PI7C7100. Otherwise, the pending queued locked transaction would not have been queued. When PI7C7100 is able to complete a data transfer with the locked read transaction, the lock is established on the secondary bus.

When the initiator repeats the locked read transaction on the primary bus with the same address, transaction type, and byte enable bits, PI7C7100 transfers the read data back to the initiator, and the lock is then also established on the primary bus.

For PI7C7100 to recognize and respond to the initiator, the initiator's subsequent attempts of the read transaction must use the locked transaction sequence (de-assert LOCK# during address phase, and assert LOCK# one cycle later). If the LOCK# sequence is not used in subsequent attempts, a master timeout condition may result. When a master timeout condition occurs, SERR# is conditionally asserted (see Section 7.4), the read data and queued read transaction are discarded, and the LOCK# signal is de-asserted on the target bus.



Once the intended target has been locked, any subsequent locked transactions initiated on the initiator bus that are forwarded by PI7C7100 are driven as locked transactions on the target bus.

When PI7C7100 receives a target abort or a master abort in response to the delayed locked read transaction, this status is passed back to the initiator, and no locks are established on either the target or the initiator bus. PI7C7100 resumes forwarding unlocked transactions in both directions.

8.3 Ending Exclusive Access

After the lock has been acquired on both initiator and target buses, PI7C7100 must maintain the lock on the target bus for any subsequent locked transactions until the initiator relinquishes the lock.

The only time a target-retry causes the lock to be relinquished is on the first transaction of a locked sequence. On subsequent transactions in the sequence, the target retry has no effect on the status of the lock signal.

An established target lock is maintained until the initiator relinquishes the lock. PI7C7100 does not know whether the current transaction is the last one in a sequence of locked transactions until the initiator de-asserts the LOCK# signal at end of the transaction.

When the last locked transaction is a delayed transaction, PI7C7100 has already completed the transaction on the secondary bus. In this example, as soon as PI7C7100 detects that the initiator has relinquished the LOCK# signal by sampling it in the de-asserted state while FRAME# is de-asserted, PI7C7100 de-asserts the LOCK# signal on the target bus as soon as possible. Because of this behavior, LOCK# may not be de-asserted until several cycles after the last locked transaction has been completed on the target bus. As soon as PI7C7100 has de-asserted LOCK# to indicate the end of a sequence of locked transactions, it resumes forwarding unlocked transactions.

When the last locked transaction is a posted write transaction, PI7C7100 de-asserts LOCK# on the target bus at the end of the transaction because the lock was relinquished at the end of the write transaction on the initiator bus.

When PI7C7100 receives a target abort or a master abort in response to a locked delayed transaction, PI7C7100 returns a target abort or a master abort when the initiator repeats the locked transaction. The initiator must then de-assert LOCK# at the end of the transaction. PI7C7100 sets the appropriate status bits, flagging the abnormal target termination condition (see Section 4.8). Normal forwarding of unlocked posted and delayed transactions is resumed.

When PI7C7100 receives a target abort or a master abort in response to a locked posted write transaction, PI7C7100 cannot pass back that status to the initiator. PI7C7100 asserts SERR# on the initiator bus when a target abort or a master abort is received during a locked posted write transaction, if the SERR# enable bit is set in the command register. Signal SERR# is asserted for the master abort condition if the master abort mode bit is set in the bridge control register (see Section 7.4).

9. PCI Bus Arbitration

PI7C7100 must arbitrate for use of the primary bus when forwarding upstream transactions. Also, it must arbitrate for use of the secondary bus when forwarding downstream transactions. The arbiter for the primary bus resides external to PI7C7100, typically on the motherboard. For the secondary PCI bus, PI7C7100 implements an internal arbiter. This arbiter can be disabled, and an external arbiter can be used instead. This chapter describes primary and secondary bus arbitration.

9.1 Primary PCI Bus Arbitration

PI7C7100 implements a request output pin, P_REQ#, and a grant input pin, P_GNT#, for primary PCI bus arbitration. PI7C7100 asserts P_REQ# when forwarding transactions upstream; that is, it acts as initiator on the primary PCI bus. As long as at least one pending transaction resides in the queues in the upstream direction, either posted write data or delayed transaction requests, PI7C7100 keeps P_REQ# asserted. However, if a target retry, target disconnect, or a target abort is received in response to a transaction initiated by PI7C7100 on the primary PCI bus, PI7C7100 de-asserts P_REQ# for two PCI clock cycles.

For all cycles through the bridge, P_REQ# is not asserted until the transaction request has been completely queued. When P_GNT# is asserted LOW by the primary bus arbiter after PI7C7100 has asserted P_REQ#, PI7C7100 initiates a transaction on the primary bus during the next PCI clock cycle. When P_GNT# is asserted to PI7C7100 when P_REQ# is not asserted, PI7C7100 parks P_AD, P_CBE, and P_PAR by driving them to valid logic levels. When the primary bus is parked at PI7C7100 and PI7C7100 has a transaction to initiate on the primary bus, PI7C7100 starts the transaction if P_GNT# was asserted during the previous cycle.

9.2 Secondary PCI Bus Arbitration

PI7C7100 implements an internal secondary PCI bus arbiter. This arbiter supports two sets of eight external masters in addition to PI7C7100. The internal arbiter can be disabled, and an external arbiter can be used instead for secondary bus arbitration.

9.2.1 Secondary Bus Arbitration Using the Internal Arbiter

To use the internal arbiter, the secondary bus arbiter enable pin, S_CFN#, must be tied LOW. PI7C7100 has two sets of eight secondary bus request input pins, S1_REQ#[7:0], S2_REQ#[7:0], and two sets of eight secondary bus output grant pins, S1_GNT#[7:0], S2_GNT#[7:0], to support external secondary bus masters. The secondary bus request and grant signals are connected internally to the arbiter and are not brought out to external pins when S_CFN# is HIGH.

The secondary arbiter supports a 2-sets programmable 2-level rotating algorithm with each set taking care of 8 requests/grants. Each set of masters can be assigned to a high priority group and a low priority group. The low priority group as a whole represents one entry in the high priority group; that is, if the high priority group consists of n masters, then in at least every n+1 transactions the highest priority is assigned to the low priority group. Priority rotates evenly among the low priority group. Therefore, members of the high priority group can be serviced n transactions out of n+1, while one member of the low priority group is serviced once every n+1 transactions. Figure 9–1 shows an example of an internal arbiter where four masters, including PI7C7100, are in the high priority group, and five masters are in the low priority group. Using this example, if all requests are always asserted, the highest priority rotates among the masters in the following fashion (high priority members are given in *italics*, low priority members, in **boldface** type):

B, m0, m1, m2, m3, **B, m0, m1, m2, m4**, *B, m0, m1, m2, m5*, **B, m0, m1, m2, m6**, *B, m0, m1, m2, m7* and so on.

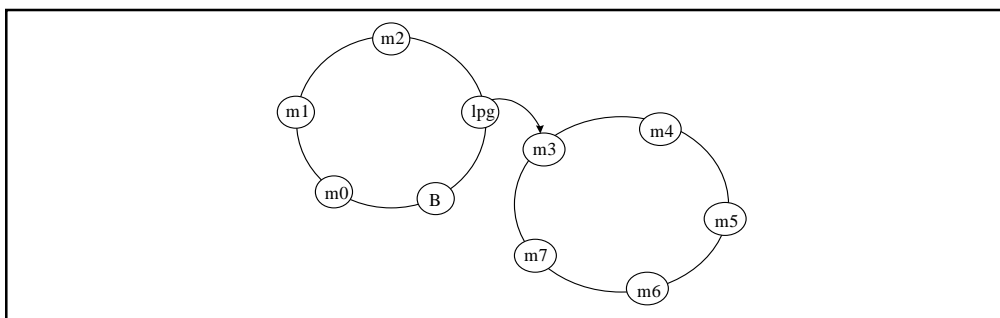

Figure 9-1. Secondary Arbiter Example



Each bus master, including PI7C7100, can be configured to be in either the low priority group or the high priority group by setting the corresponding priority bit in the arbiter-control register. The arbiter-control register is located at offset 40h. Each master has a corresponding bit. If the bit is set to 1, the master is assigned to the high priority group. If the bit is set to 0, the master is assigned to the low priority group. If all the masters are assigned to one group, the algorithm defaults to a straight rotating priority among all the masters. After reset, all external masters are assigned to the low priority group, and PI7C7100 is assigned to the high priority group. PI7C7100 receives highest priority on the target bus every other transaction, and priority rotates evenly among the other masters.

Priorities are re-evaluated every time S1_FRAME# or S2_FRAME# is asserted at the start of each new transaction on the secondary PCI bus. From this point until the time that the next transaction starts, the arbiter asserts the grant signal corresponding to the highest priority request that is asserted. If a grant for a particular request is asserted, and a higher priority request subsequently asserts, the arbiter de-asserts the asserted grant signal and asserts the grant corresponding to the new higher priority request on the next PCI clock cycle. When priorities are re-evaluated, the highest priority is assigned to the next highest priority master relative to the master that initiated the previous transaction. The master that initiated the last transaction now has the lowest priority in its group.

If PI7C7100 detects that an initiator has failed to assert S1_FRAME# or S2_FRAME# after 16 cycles of both grant assertion and a secondary idle bus condition, the arbiter de-asserts the grant. That master does not receive any more grants until it de-asserts its request for at least one PCI clock cycle.

To prevent bus contention, if the secondary PCI bus is idle, the arbiter never asserts one grant signal in the same PCI cycle in which it de-asserts another. It de-asserts one grant and asserts the next grant, no earlier than one PCI clock cycle later. If the secondary PCI bus is busy, that is, either S1_FRAME# (S2_FRAME#) or S1_IRDY# (S2_IRDY#) is asserted, the arbiter can de-assert one grant and assert another grant during the same PCI clock cycle.

9.2.2 Secondary Bus Arbitration Using an External Arbiter

The internal arbiter is disabled when the secondary bus central function control pin, S_CFN#, is tied high. An external arbiter must then be used.

When S_CFN# is tied high, PI7C7100 reconfigures four pins (two per port) to be external request and grant pins. The S1_GNT#[0] and S2_GNT#[0] pins are reconfigured to be the external request pins because they are output. The S1_REQ#[0] and S2_REQ#[0] pins are reconfigured to be the external grant pins because they are input. When an external arbiter is used, PI7C7100 uses the S1_GNT#[0] or S2_GNT#[0] pin to request the secondary bus. When the reconfigured S1_REQ#[0] or S2_REQ#[0] pin is asserted low after PI7C7100 has asserted S1_GNT#[0] or S2_GNT#[0], PI7C7100 initiates a transaction on the secondary bus one cycle later. If grant is asserted and PI7C7100 has not asserted the request, PI7C7100 parks AD, CBE and PAR pins by driving them to valid logic levels.

The unused secondary bus grant outputs, S1_GNT#[7:1] and S2_GNT#[7:1] are driven high. The unused secondary bus request inputs, S1_REQ#[7:1] and S2_REQ#[7:1], should be pulled high.

9.2.3 Bus Parking

Bus parking refers to driving the AD[31:0], CBE[3:0]#, and PAR lines to a known value while the bus is idle. In general, the device implementing the bus arbiter is responsible for parking the bus or assigning another device to park the bus. A device parks the bus when the bus is idle, its bus grant is asserted, and the device's request is not asserted. The AD and CBE signals should be driven first, with the PAR signal driven one cycle later.

PI7C7100 parks the primary bus only when P_GNT# is asserted, P_REQ# is de-asserted, and the primary PCI bus is idle. When P_GNT# is de-asserted, PI7C7100 3-states the P_AD, P_CBE, and P_PAR signals on the next PCI clock cycle. If PI7C7100 is parking the primary PCI bus and wants to initiate a transaction on that bus, then PI7C7100 can start the transaction on the next PCI clock cycle by asserting P_FRAME# if P_GNT# is still asserted.

If the internal secondary bus arbiter is enabled, the secondary bus is always parked at the last master that used the PCI bus. That is, PI7C7100 keeps the secondary bus grant asserted to a particular master until a new secondary bus request comes along. After reset, PI7C7100 parks the secondary bus at itself until transactions start occurring on the secondary bus. If the internal arbiter is disabled, PI7C7100 parks the secondary bus only when the reconfigured grant signal, S_REQ#<0>, is asserted and the secondary bus is idle.

10. Clocks

This chapter provides information about the clocks.

10.1 Primary Clock Inputs

PI7C7100 implements a primary clock input for the PCI interface. The primary interface is synchronized to the primary clock input, P_CLK, and the secondary interface is synchronized to the secondary clock. The secondary clock is derived internally from the primary clock, P_CLK, through an internal PLL.

PI7C7100 operates at a maximum frequency of 33 MHz.

10.2 Secondary Clock Outputs

PI7C7100 has 16 secondary clock outputs, S_CLKOUT[15:0] that can be used as clock inputs for up to sixteen external secondary bus devices. The S_CLKOUT[15:0] outputs are derived from P_CLK. The secondary clock edges are delayed from P_CLK edges by a minimum of 0ns.

This is the rule for using secondary clocks:

- Each secondary clock output is limited to no more than one load.

11. Reset

This chapter describes the primary interface, secondary interface, and chip reset mechanisms.

11.1 Primary Interface Reset

PI7C7100 has a reset input, P_RESET#. When P_RESET# is asserted, the following events occur:

- PI7C7100 immediately 3-states all primary and secondary PCI interface signals.
- PI7C7100 performs a chip reset.
- Registers that have default values are reset.

P_RESET# asserting and de-asserting edges can be asynchronous to P_CLK and S_CLK.

11.2 Secondary Interface Reset

PI7C7100 is responsible for driving the secondary bus reset signals, S1_RESET# and S2_RESET#.

PI7C7100 asserts S1_RESET# or S2_RESET# when any of the following conditions is met:

- Signal P_RESET# is asserted.
Signal S1_RESET# or S2_RESET# remains asserted as long as P_RESET# is asserted and does not de-assert until P_RESET# is de-asserted.
- The secondary reset bit in the bridge control register is set.
Signal S1_RESET# or S2_RESET# remains asserted until a configuration write operation clears the secondary reset bit.
- S1_RESET# or S2_RESET# pin is asserted.
When S1_RESET# or S2_RESET# is asserted, the following events occur:
PI7C7100 immediately 3-states all the secondary PCI interface signals associated with the Secondary S1 or S2 port.
The S1_RESET# or S2_RESET# in asserting and de-asserting edges can be asynchronous to P_CLK.
- The chip reset bit in the diagnostic control register is set.
Signal S1_RESET# or S2_RESET# remains asserted until a configuration write operation clears the secondary reset bit and the secondary clock serial mask has been shifted in.

When S1_RESET# or S2_RESET# is asserted, all secondary PCI interface control signals, including the secondary grant outputs, are immediately 3-stated. Signals S1_AD, S1_CBE[3:0]#, S1_PAR (S2_AD, S2_CBE[3:0]#, S2_PAR) are driven low for the duration of S1_RESET# (S2_RESET#) assertion. All posted write and delayed transaction data buffers are reset. Therefore, any transactions residing inside the buffers at the time of secondary reset are discarded.

When S1_RESET# or S2_RESET# is asserted by means of the secondary reset bit, PI7C7100 remains accessible during secondary interface reset and continues to respond to accesses to its configuration space from the primary interface.

11.3 Chip Reset

The chip reset bit in the diagnostic control register can be used to reset PI7C7100 and the secondary buses. All registers, and chip state machines are reset and all signals are 3-stated when the chip reset is set. In addition, S1_RESET# or S2_RESET# is asserted, and the secondary reset bit is automatically set. Signal S1_RESET# or S2_RESET# remains asserted until a configuration write operation clears the secondary reset bit.

As soon as chip reset completes, within 20 PCI clock cycles after completion of the configuration write operation that sets the chip reset bit, the chip reset bit automatically clears and the chip is ready for configuration.

During chip reset, PI7C7100 is inaccessible.



12. Supported Commands

The PCI command set is given below for the primary and secondary interfaces.

12.1 Primary Interface

P_CBE[3:0]#	Command	Action
0000	Interrupt Acknowledge	Ignore.
0001	Special Cycle	Do not claim. Ignore.
0010	I/O Read	<ol style="list-style-type: none"> 1. If address is within pass through I/O range: claim and pass through. 2. If address points to I/O mapped bridge internal register: claim and permit access to register, do not pass through. 3. Otherwise, do not pass through and do not claim for internal access.
0011	I/O Write	Same as I/O read.
0100	Reserved	-----
0101	Reserved	-----
0110	Memory Read	<ol style="list-style-type: none"> 1. If address is within pass through memory range: claim and pass through. 2. If address is within pass through memory mapped I/O range: claim and pass through. 3. If address points to memory mapped bridge internal register: claim and permit access to register, do not pass through. 4. Otherwise, do not pass through and do not claim for internal access.
0111	Memory Write	Same as Memory Read
1000	Reserved	-----
1001	Reserved	-----
1010	Configuration Read	<p>I. Type 0 configuration read: If the bridge's IDSEL line is asserted, perform function decode and claim if target function is implemented, otherwise, ignore. If claimed, permit access to target function's configuration registers. Do not pass through under any circumstances.</p> <p>II. Type 1 configuration read:</p> <ol style="list-style-type: none"> 1. If the target bus is the bridge's secondary bus: claim and pass through as a type 0 configuration read. 2. If the target bus is a subordinate bus that exists behind the bridge (but not equal to the secondary bus): claim and pass through as a type 1 configuration read. 3. Otherwise, ignore.



12.1 Primary Interface (continued)

P_CBE[3:0]#	Command	Action
1011	Configuration Write	<p>I. Type 0 configuration write: same as configuration read.</p> <p>II. Type 1 configuration write(not special cycle request):</p> <ol style="list-style-type: none"> 1. If the target bus is the bridge's secondary bus: claim and pass through as a type 0 configuration write 2. If the target bus is a subordinate bus that exists behind the bridge (but not equal to the secondary bus): claim and pass through unchanged as a type 1 configuration write. 3. Otherwise, ignore. <p>III. Configuration write as special cycle request (device = 1Fh, function = 7h):</p> <ol style="list-style-type: none"> 1. If the target bus is the bridge's secondary bus: claim and pass through as a special cycle 2. If the target bus is a subordinate bus that exists behind the bridge (but not equal to the secondary bus): claim and pass through unchanged as a type 1 configuration write. 3. Otherwise, ignore
1100	Memory Read Multiple	Same as Memory Read
1101	Dual Address Cycle	Not Supported
1110	Memory Read Line	Same as Memory Read
1111	Memory Write & Invalidate	Same as Memory Read



12.2 Secondary Interface

S1_CBE[3:0]# S2_CBE[3:0]#	Command	Action
0000	Interrupt Acknowledge	Ignore.
0001	Special Cycle	Do not claim. Ignore.
0010	I/O Read	Same as primary interface.
0011	I/O Write	Same as I/O read.
0100	Reserved	-----
0101	Reserved	-----
0110	Memory Read	Same as primary interface.
0111	Memory Write	Same as Memory Read.
1000	Reserved	-----
1001	Reserved	-----
1010	Configuration Read	Ignore.
1011	Configuration Write	<p>I. Type 0 configuration write: Ignore.</p> <p>II. Type 1 configuration write (not special cycle request): Ignore.</p> <p>III. Configuration write as special cycle request (device = 1Fh, function = 7h):</p> <ol style="list-style-type: none"> 1. If the target bus is the bridge's primary bus: claim and pass through as a special cycle. 2. If the target bus is neither the primary bus nor is it in range of buses defined by the bridge's secondary and subordinate bus registers: claim and pass through unchanged as a type 1 configuration write. 3. If the target bus is not the bridge's primary bus: but is in range of buses defined by the bridge's secondary and subordinate bus registers: Ignore.
1100	Memory Read Multiple	Same as Memory Read
1101	Dual Address Cycle	Not Supported
1110	Memory Read Line	Same as Memory Read
1111	Memory Write & Invalidate	Same as Memory Read



13. Configuration Registers

As PI7C7100 supports two secondary interfaces, it has two sets of configuration registers which are almost identical and accessed through different function numbers. The description below is for one set only.

PCI configuration defines a 64-byte space (configuration header) to define various attributes of the PCI-to-PCI Bridge as shown below. All of the registers in bold type are required by the PCI specification and are implemented in this bridge. The others are available for use as control registers for the device. There are two configuration registers: Configuration Register 1 and Configuration Register 2 corresponding to Secondary bus 1 and Secondary bus 2 interfaces respectively. Also, the configuration for the primary interface is implemented through the Configuration Register 1.

13.1 Configuration Register 1

31-24	23-16	15-8	7-0	Address
Device ID		Vendor ID		00h
Status		Command		04h
Class Code			Revision ID	08h
Reserved	Header Type	Primary Latency Timer	Cache Line Size	0Ch
Reserved				10h-14h
Secondary Latency Timer	Subordinate Bus Number	Secondary Bus Number	Primary Bus Number	18h
Secondary Status		I/O Limit	I/O Base	1Ch
Memory Limit		Memory Base		20h
Prefetchable Memory Limit		Prefetchable Memory Base		24h
Reserved				28h-2Ch
I/O Limit Upper 16 Bits		I/O Base Upper 16 Bits		30h
Subsystem ID		Subsystem Vendor ID		34h
Reserved				38h
Bridge Control		Interrupt Pin	Reserved	3Ch
Arbiter Control		Diagnostic Control	Chip Control	40h
Primary Prefetchable Memory Limit		Primary Prefetchable Memory Base		44h
Reserved				48h-60h
Reserved			P_SERR# Event Disable	64h
Reserved	Reserved	Secondary Clock Control		68h
Reserved				6Ch
Non-Posted Memory Limit		Non-Posted Memory Base		70h
Master Timeout Counter		Port Option		74h
Retry Counter				78h
Sampling Timer				7Ch
Secondary Successful I/O read count				80h
Secondary Successful I/O write count				84h
Secondary Successful memory read count				88h
Secondary Successful memory write count				8Ch
Primary Successful I/O read count				90h
Primary Successful I/O write count				94h
Primary Successful memory read count				98h
Primary Successful memory write count				9Ch
Reserved				A0h-FFh



13.2 Configuration Register 2

31-24	23-16	15-8	7-0	Address
Device ID		Vendor ID		00h
Status		Command		04h
Class Code			Revision ID	08h
Reserved	Header Type	Primary Latency Timer	Cache Line Size	0Ch
Reserved				10h-14h
Secondary Latency Timer	Subordinate Bus Number	Secondary Bus Number	Primary Bus Number	18h
Secondary Status		I/O Limit	I/O Base	1Ch
Memory Limit		Memory Base		20h
Prefetchable Memory Limit		Prefetchable Memory Base		24h
Reserved				28h-2Ch
I/O Limit Upper 16 Bits		I/O Base Upper 16 Bits		30h
Subsystem ID		Subsystem Vendor ID		34h
Reserved				38h
Bridge Control		Interrupt Pin	Reserved	3Ch
Arbiter Control		Diagnostic Control	Chip Control	40h
Primary Prefetchable Memory Limit		Primary Prefetchable Memory Base		44h
Reserved				48h-60h
Reserved				64h
Reserved	Reserved	Secondary Clock Control		68h
Reserved				6Ch
Non-Posted Memory Limit		Non-Posted Memory Base		70h
Reserved		Reserved		74h
Reserved				78h
Sampling Timer				7Ch
Secondary Successful I/O read count				80h
Secondary Successful I/O write count				84h
Secondary Successful memory read count				88h
Secondary Successful memory write count				8Ch
Reserved				90h
Reserved				94h
Reserved				98h
Reserved				9Ch
Reserved				A0h-FFh



13.2.1 Config Register 1 or 2: Vendor ID Register (read only, bit 15-0; offset 00h)

Pericom ID is 12D8h.

13.2.2 Config Register 1: Device ID Register (read only, bit 31-16; offset 00h)

Hardwired to 1B59h (S1)

13.2.3 Config Register 2: Device ID Register (read only, bit 31-16; offset 00h)

Hardwired to 1B5Ah (S2)

13.2.4 Configuration Register 1: Command Register (bit 15-0; offset 04h)

Bit	Function	Type	Description
15-10	Reserved	R/O	Reset to '000000'
9	Fast Back to Back Enable	R/W	Controls bridge's ability to generate fast back-to-back transactions to different devices on the primary interface. 0 = no fast back to back transaction 1 = enable fast back to back transaction Reset to 0
8	SERR# Enable	R/W	Controls the enable for the P_SERR# pin. 0=disable the P_SERR# driver 1 = enable the P_SERR# driver Reset to 0
7	Wait Cycle Control	R/O	No data stepping supported. Reset to 0
6	Parity Error Enable	R/W	Controls bridge's response to parity errors. 0 = ignore any parity errors 1 = normal parity checking performed Reset to 0
5	VGA Palette Snoop Enable	R/W	Controls bridge's response to VGA compatible palette accesses. 0 = ignore VGA palette accesses on the primary interface 1 = enable response to VGA palette writes on the primary interface (I/O address AD[9:0] = 3C6h, 3C8h and 3C9h) Reset to 0
4	Memory Write and Invalidate Enable	R/O	Memory Write and Invalidate not supported Reset to 0
3	Special Cycle Enable	R/O	No special cycle implementation Reset to 0
2	Bus Master Enable	R/W	Controls bridge's ability to operate as a master on the primary interface. 0 = do not initiate transaction on the primary interface and disable response to memory or I/O transactions on secondary interface 1 = enable the bridge to operate as a master on the primary interface Reset to 0
1	Memory Space Enable	R/W	Controls bridge's response to memory accesses on the primary interface. 0 = ignore all memory transaction 1 = enable response to memory transaction Reset to 0
0	I/O Space Enable	R/W	Controls bridge's response to I/O accesses on the primary interface. 0 = ignore I/O transaction 1 = enable response to I/O transaction Reset to 0

Note: R/W - Read/Write, R/O - Read Only, R/WC - Read/ Write 1 to clear



13.2.5 Configuration Register 2: Command Register (bit 15-0; offset 04h)

Bit	Function	Type	Description
15-10	Reserved	R/O	Reset to '000000'
9	Reserved	R/W	Reset to 0
8	Reserved	R/W	Reset to 0
7	Wait Cycle Control	R/O	No data stepping supported. Reset to 0
6	Reserved	R/W	Reset to 0
5	VGA Palette Snoop Enable	R/W	Controls bridge's response to VGA compatible palette accesses. 0 = ignore VGA palette accesses on the primary interface 1 = enable response to VGA palette writes on the primary interface (I/O address AD[9:0] = 3C6h, 3C8h and 3C9h) Reset to 0
4	Memory Write and Invalidate Enable	R/O	Memory Write and Invalidate not supported. Reset to 0
3	Special Cycle Enable	R/O	No special cycle implementation. Reset to 0
2	Bus Master Enable	R/W	Controls bridge's ability to operate as a master on the primary interface. 0 = do not initiate transaction on the primary interface and disable response to memory or I/O transactions on secondary interface 1 = enable the bridge to operate as a master on the primary interface Reset to 0
1	Memory Space Enable	R/W	Controls bridge's response to memory accesses on the primary interface. 0 = ignore all memory transaction 1 = enable response to memory transaction Reset to 0
0	I/O Space Enable	R/W	Controls bridge's response to I/O accesses on the primary interface. 0 = ignore I/O transaction 1 = enable response to I/O transaction Reset to 0

Note: R/W - Read/Write, R/O - Read Only, R/WC - Read/ Write 1 to clear



13.2.6 Configuration Register 1 or 2: Status Register (for primary bus, bits 31-16; offset 04h)

Bit	Function	Type	Description
31	Detected Parity Error	R/WC	Should be set whenever a parity error is detected regardless of the state of bit 6 of the command register. Reset to 0
30	Signaled System Error	R/WC	Should be set whenever P_SERR# is asserted. Reset to 0
29	Received Master Abort	R/WC	Set to '1' (by a master) when transactions are terminated with Master Abort. Reset to 0
28	Received Target Abort	R/WC	Set to '1' (by a master device) when transactions are terminated with Target Abort. Reset to 0
27	Signaled Target Abort	R/WC	Should be set (by a target device) whenever a Target Abort cycle occurs. Reset to 0
26-25	DEVSEL Timing	R/O	Medium DEVSEL# timing. Reset to '01'
24	Data Parity Error Detected	R/WC	It is set when the following conditions are met: 1. P_PERR# is asserted 2. Bit 6 of Command Register is set Reset to 0
23	Fast Back to Back Capable	R/O	Fast back-to-back write capable on primary side. Reset to 1
22	Reserved	R/O	Reset to 0
21	Reserved	R/O	Reset to 1
20	Capabilities List	R/O	Capabilities List is not supported. Reset to 0
19-16	Reserved	R/O	Reset to 0

Note: R/W - Read/Write; R/O - Read Only; R/WC - Read/Write1 to clear.

**13.2.7 Config Register 1 or 2: Revision ID Register (read only, bit 7-0; offset 08h)**

Hardwired to 01h

13.2.8 Config Register 1 or 2: Class Code Register (read only, bit 31-8; offset 08h)

Hardwired to 060400h

13.2.9 Config Register 1 or 2: Cache Line Size Register (read/write, bit 7-0; offset 0Ch)

This register is used when terminating memory write and invalidate transactions and when pre-fetching.

Only cache line sizes (in units of 4-byte) which are power of two are valid (only one bit can be set in this register; only 00h, 01h, 02h, 04h, 08h, 10h are valid values). Reset to 00h

13.2.10 Config Register 1: Primary Latency Timer Register (read/write, bit 15-8; offset 0Ch)

This register sets the value for Master Latency Timer which starts counting when master asserts FRAME#. Reset to 00h

13.2.11 Config Register 2: Primary Latency Timer Register (read/write, bit 15-8; offset 0Ch)

This register is implemented but not being used internally. Reset to 00h

13.2.12 Config Register 1: Header Type Register (read only, bit 23-16; offset 0Ch)

Hardwired to 81h for function 0 (multiple function PCI-to-PCI bridge, for secondary bus S1)

13.2.13 Config Register 2: Header Type Register (read only, bit 23-16; offset 0Ch)

Hardwired to 01h for function 1 (single function PCI-to-PCI bridge, for secondary bus S2)

13.2.14 Config Register 1: Primary Bus Number Register (read/write, bit 7-0; offset 18h)

Programmed with the number of the PCI bus to which the primary bridge interface is connected.

This value is set by software during configuration. Reset to 00h

13.2.15 Config Register 2: Primary Bus Number Register (read/write, bit 7-0; offset 18h)

This register is implemented but not being used internally. Reset to 00h

13.2.16 Config Register 1 or 2: Secondary Bus Number Register (read/write, bit 15-8; offset 18h)

Programmed with the number of the PCI bridge secondary bus interface. This value is set by software during configuration. Reset to 00h

13.2.17 Config Register 1 or 2: Subordinate Bus Number Register (read/write, bit 23-16; offset 18h)

Programmed with the number of the PCI bus with the highest number that is subordinate to the bridge.

This value is set by software during configuration. Reset to 00h

13.2.18 Config Register 1 or 2: Secondary Latency Timer (read/write, bit 31-24; offset 18h)

This register is programmed in units of PCI bus clocks. The latency timer checks for master accesses on the secondary bus interfaces that remain unclaimed by any target. Reset to 00h

13.2.19 Config Register 1 or 2: I/O Base Register (read/write, bit 7-0; offset 1Ch)

This register defines the bottom address of the I/O address range for the bridge. The upper four bits define the bottom address range used by the chip to determine when to forward I/O transactions from one interface to the other. These 4 bits correspond to address bits [15:12] and are write-able. The upper 16 bits corresponding to address bits [31:16] are defined in the I/O base upper 16 bits address register. The address bits [11:0] are assumed to be 000h. The lower four bits (3:0) of this register set to '0001' (read-only) to indicate 32-bit I/O addressing. Reset to 00h

13.2.20 Config Register 1 or 2: I/O Limit Register (read/write, bit 15-8; offset 1Ch)

This register defines the top address of the I/O address range for the bridge. The upper four bits define the top address range used by the chip to determine when to forward I/O transactions from one interface to the other. These 4 bits correspond to address bits [15:12] and are write-able. The upper 16 bits corresponding to address bits [31:16] are defined in the I/O limit upper 16 bits address register. The address bits [11:0] are assumed to be FFFh. The lower four bits (3:0) of this register set to '0001' (read-only) to indicate 32-bit I/O addressing. Reset to 00h.



13.2.21 Configuration Register 1 or 2: Secondary Status Register (bits 31-16; offset 1Ch)

Bit	Function	Type	Description
31	Detected Parity Error	R/WC	Should be set whenever a parity error is detected regardless of the state of bit 6 of the command register. Reset to 0
30	Signaled System Error	R/WC	Should be set whenever S1_SERR# or S2_SERR# is detected. Should be a '0' after reset. Reset to 0
29	Received Master Abort	R/WC	Set to '1' (by a master) when transactions are terminated with Master Abort. Reset to 0
28	Received Target Abort	R/WC	Set to '1' (by a master device) when transactions are terminated with Target Abort. Reset to 0
27	Signaled Target Abort	R/WC	Should be set (by a target device) whenever a Target Abort cycle occurs. Should be '0' after reset. Reset to 0
26-25	DEVSEL timing	R/O	Medium DEVSEL# timing. Reset to '01'
24	Data Parity Error Detected	R/WC	It is set when the following conditions are met: 1. S1_PERR# or S2_PERR# is asserted 2. Bit 6 of Command Register is set Reset to 0
23	Fast Back-to-Back Capable	R/O	Fast back-to-back write capable on secondary buses. Reset to 1
22	Reserved	R/O	Reset to 0
21	Reserved	R/O	Reset to 0
20-16	Reserved	R/O	Reset to '00000'

Note: R/W - Read/Write, R/O - Read Only, R/WC - Read/ Write 1 to clear

13.2.22 Config Register 1 or 2: Memory Base Register (read/write, bit 15-0; offset 20h)

This register defines the base address of the memory-mapped address range for forwarding the cycle through the bridge. The upper twelve bits corresponding to address bits [31:20] are read/write. The twelve bits are reset to 000h. The lower 20 address bits (19:0) are assumed to be 00000h.

13.2.23 Config Register 1 or 2: Memory Limit Register (read/write, bit 31-16; offset 20h)

This register defines the upper limit address of the memory-mapped address range for forwarding the cycle through the bridge. Upper twelve bits corresponding to address bit [31:20] are read/write. Upper twelve bits are reset to 0000h. Lower 20 address bits (19:0) are assumed to be FFFFFh.

13.2.24 Config Register 1 or 2: Prefetchable Memory Base Register (read/write, bit 15-0; offset 24h)

This register defines the base address of the prefetchable memory-mapped address range for forwarding the cycle through the bridge. The upper twelve bits corresponding to address bits [31:20] are read/write. The upper twelve bits are reset to 000h. The lower four bits are read only and are set to 0. The lower 20 address bits (19:0) are assumed to be 00000h.

13.2.25 Config Register 1 or 2: Prefetchable Memory Limit Register (read/write, bit 31-16; offset 24h)

This register defines the upper limit address of the memory-mapped address range for forwarding the cycle through the bridge. The upper twelve bits correspond to address bit [31:20] are read/write. The upper twelve bits are reset to 000h. The lower four bits are read only and are set to 0. The lower 20 address bits (19:0) are assumed to be FFFFFh.

13.2.26 Config Register 1 or 2: I/O Base Address Upper 16 Bits Register (read/write, bit 15-0; offset 30h)

This register defines the upper 16 bits of a 32-bit base I/O address range used for forwarding the cycle through the bridge.

Reset to 0000h.

13.2.27 Config Register 1 or 2: I/O Limit Address Upper 16 Bits Register (read/write, bit 31-16; offset 30h)

This register defines the upper 16 bits of a 32-bit limit I/O address range used for forwarding the cycle through the bridge.

Reset to 0000h.

13.2.28 Config Register 1 or 2: Subsystem Vendor ID (read/write, bit 15-0; offset 34h)

A 16-bit register for add-on cards to distinguish from one another. Reset to 0000h.

13.2.29 Config Register 1 or 2: Subsystem ID (read/write, bit 31-16; offset 34h)

A 16-bit register for add-on cards to distinguish from one another. Reset to 0000h.

13.2.30 Config Register 1 or 2: Interrupt Pin Register (read only, bit 15-8; offset 3Ch)

The register reads as 00h to indicate that PI7C7100 does not use any interrupt pins.

13.2.31 Configuration Register 1 or 2: Bridge Control Register (bits 31-16; offset 3Ch)

Bit	Function	Type	Description
31-28	Reserved	R/O	Reset to '0000'
27	Reserved	R/W	Reset to 0
26	Master Timeout Status	R/WC	Set to '1' when either primary master or secondary master timeout. Reset to 0
25	Reserved	R/W	Reset to 0
24	Reserved	R/W	Reset to 0
23	Fast Back-to-Back Enable	R/W	Controls bridge's ability to generate fast back-to-back transactions to different devices on the secondary interface. 0 = no fast back-to-back transaction 1 = enable fast back-to-back transaction Reset to 0
22	Secondary Interface Reset	R/W	Forces the assertion of S1_RESET# or S2_RESET# signal pin on the secondary interface. 0 = do not force the assertion of S1_RESET# or S2_RESET# pin 1 = force the assertion of S1_RESET# or S2_RESET# pin Reset to 0
21	Master Abort Mode	R/W	Controls bridge's behavior responding to master aborts on secondary interface. 0 = do not report master aborts (return FFFF_FFFFh on read and discard data on write) 1 = report master aborts by signaling target abort if possible by the assertion of P_SERR# if enabled Reset to 0
20	Reserved	R/O	Reset to 0
19	VGA Enable	R/W	Controls the bridge's response to VGA compatible addresses. 0 = do not forward VGA compatible memory and I/O addresses from primary to secondary 1 = forward VGA compatible memory and I/O address from primary to secondary regardless of other settings Reset to 0
18	ISA Enable	R/W	Controls bridge's response to ISA I/O address which is limited to the first 64K. 0 = forward all I/O addresses in the range defined by the I/O Base and I/O Limit registers, 1 = block forwarding of ISA I/O addresses in the range defined by the I/O Base and I/O Limit registers that are in the first 64K of I/O space that address the last 768 bytes in each 1 Kbytes block. Secondary I/O transactions are forwarded upstream if the address falls within the last 768 bytes in each 1 Kbyte block Reset to 0
17	S1_SERR# or S2_SERR# Enable		Controls the forwarding of S1_SERR# or S2_SERR# to the primary interface. 0 = disable the forwarding S1_SERR# or S2_SERR# to primary 1 = enable the forwarding of S1_SERR# or S2_SERR# to primary interface. Reset to 0
16	Parity Error Response Enable		Controls the bridge's response to parity errors on the secondary interface. 0 = ignore address and data parity errors on the secondary interface. 1 = enable parity error reporting and detection on the secondary interface. Reset to 0

Note: R/W - Read/Write, R/O - Read Only, R/WC - Read/ Write 1 to clear.

13.2.32 Configuration Register 1 or 2: Diagnostic/Chip Control Register (bit 15-0, offset 40h)

Bit	Function	Type	Description
15-11	Reserved	R/O	Reset to '00000'
10-9	Test Mode	R/W	Controls testability of chip's internal counters. When 00, all bits of counter are exercised. When 01, byte 1 of counter is exercised. When 10, byte 2 of counter is exercised. When 11, byte 3 of counter is exercised. Reset to 0
8-5	Reserved	R/O	Reset to '0000'
4	Reserved	R/W	Reset to 0
3-2	Reserved	R/O	Reset to '00'
1	Reserved	R/W	Reset to 0
0	Reserved	R/O	Reset to 0

13.2.33 Configuration Register 1 or 2: Arbiter Control Register (bit 31-16, offset 40h)

Bit	Function	Type	Description
31-28	Reserved	R/O	Reset to '0000'
27	Hybrid	R/W	Mixed arbitration for masters from secondary bus 1 and 2. 0 = separate arbitration for S1_REQ[7:0]# and S2_REQ[7:0]# 1 = S1_REQ[3:0]# are mixed with S2_REQ[3:0]# for arbitration. Only one arbiter is used. Reset to 0
26	Reserved	R/W	Reset to 0
25	Priority of Secondary Port	R/W	Defines whether the secondary port of PI7C7100 is in high priority group or the low priority group. 0 = low priority group 1 = high priority group Reset to 1
24	Reserved	R/O	Reset to 0
23-16	Arbiter Control	R/W	Each bit controls whether a secondary-bus master is assigned to the high priority group or the low priority group. Bit [7:0] correspond to request inputs S1_REQ[7:0]# or S2_REQ[7:0]#. Reset to '00000000'

Note: R/W - Read/Write, R/O - Read Only, R/WC - Read/ Write 1 to clear.



13.2.34 Config Register 1: Primary Prefetchable Memory Base Register (Read/Write, bit 15-0; offset 44h)

This register is implemented but not being used internally. This register defines the base address of the primary prefetchable memory-mapped address range for forwarding the cycle through the bridge. The upper twelve bits corresponding to address bits [31:20] are read/write. The upper twelve bits are reset to 0000h. The lower four bits are read only and are set to 0h. The lower 20 address bits (19:0) are assumed to be 00000h.

13.2.35 Config Register 2: Primary Prefetchable Memory Base Register (Read/Write, bit 15-0; offset 44h)

This register is implemented but not being used internally. The upper twelve bits corresponding to address bits [31:20] are read/write. The upper twelve bits are reset to 0000h. The lower four bits are read only and are set to 0h.

13.2.36 Config Register 1: Primary Prefetchable Memory Limit Register (Read/Write, bit 31-16; offset 44h)

This register is implemented but not being used internally. This register defines the upper limit address of the primary prefetchable memory-mapped address range for forwarding the cycle through the bridge. The upper twelve bits corresponding to address bits [31:20] are read/write. The upper twelve bits are reset to 0000h. The lower four bits are read only and are set to 0h. The lower 20 address bits (19:0) are assumed to be FFFFFh.

13.2.37 Config Register 2: Primary Prefetchable Memory Limit Register (Read/Write, bit 31-16; offset 44h)

This register is implemented but not being used internally. The upper twelve bits corresponding to address bits [31:20] are read/write. The upper twelve bits are reset to 0000h. The lower four bits are read only and are set to 0h.

13.2.38 Config Register 1 or 2: P_SERR# Event Disable Register (bit 7-0; offset 64h)

Bit	Function	Type	Description
7	Reserved	R/O	Reset to 0
6	Delayed read - no data from target	R/W	Controls ability of PI7C7100 to assert P_SERR# when it is unable to transfer any read data from the target after 2 ²⁴ attempts. P_SERR# is asserted if this event occurs when this bit is 0 and SERR# enable bit in the command register is set. Reset to 0
5	Delayed write nondeliver	R/W	Controls ability of PI7C7100 to assert P_SERR# when it is unable to transfer delayed write data after 2 ²⁴ attempts. P_SERR# is asserted if this event occurs when this bit is 0 and SERR# enable bit in the command register is set. Reset to 0
4	Master abort on posted write	R/W	Controls ability of PI7C7100 to assert P_SERR# when it receives a master abort when attempting to deliver posted write data. P_SERR# is asserted if this event occurs when this bit is 0 and SERR# enable bit in the command register is set. Reset to 0
3	Target abort during posted write	R/W	Controls ability of PI7C7100 to assert P_SERR# when it receives a target abort when attempting to deliver posted write data. P_SERR# is asserted if this event occurs when this bit is 0 and SERR# enable bit in the command register is set. Reset to 0
2	Posted write non-delivery	R/W	Controls ability of PI7C7100 to assert P_SERR# when it is unable to deliver posted write data after 2 ²⁴ attempts. P_SERR# is asserted if this event occurs when this bit is 0 and SERR# enable bit in the command register is set. Reset to 0
1	Posted write parity error	R/W	Controls ability of PI7C7100 to assert P_SERR# when a parity error is detected on the target bus during a posted write transaction. P_SERR# is asserted if this event occurs when this bit is 0 and SERR# enable bit in the command register is set. Reset to 0
0	Reserved	R/O	Reset to 0

Note: R/W - Read/Write, R/O - Read Only, R/WC - Read/ Write 1 to clear.

13.2.39 Configuration Register 1: Secondary Clock Control Register (bit 15-0; offset 68h)

Bit	Function	Type	Description
15-14	Clock 7 Disable	R/W	If either bit is 0, S_CLKOUT[7] is enabled When both bits are 1, S_CLKOUT[7] is disabled
13-12	Clock 6 Disable		If either bit is 0, S_CLKOUT[6] is enabled When both bits are 1, S_CLKOUT[6] is disabled
11-10	Clock 5 Disable		If either bit is 0, S_CLKOUT[5] is enabled When both bits are 1, S_CLKOUT[5] is disabled
9-8	Clock 4 Disable		If either bit is 0, S_CLKOUT[4] is enabled When both bits are 1, S_CLKOUT[4] is disabled
7-6	Clock 3 Disable		If either bit is 0, S_CLKOUT[3] is enabled When both bits are 1, S_CLKOUT[3] is disabled
5-4	Clock 2 Disable		If either bit is 0, S_CLKOUT[2] is enabled When both bits are 1, S_CLKOUT[2] is disabled
3-2	Clock 1 Disable		If either bit is 0, S_CLKOUT[1] is enabled When both bits are 1, S_CLKOUT[1] is disabled
1-0	Clock 0 Disable		If either bit is 0, S_CLKOUT[0] is enabled When both bits are 1, S_CLKOUT[0] is disabled

13.2.40 Configuration Register 2: Secondary Clock Control Register (bit 15-0; offset 68h)

Bit	Function	Type	Description
15-14	Clock 7 Disable	R/W	If either bit is 0, S_CLKOUT[15] is enabled When both bits are 1, S_CLKOUT[15] is disabled
13-12	Clock 6 Disable		If either bit is 0, S_CLKOUT[14] is enabled When both bits are 1, S_CLKOUT[14] is disabled
11-10	Clock 5 Disable		If either bit is 0, S_CLKOUT[13] is enabled When both bits are 1, S_CLKOUT[13] is disabled
9-8	Clock 4 Disable		If either bit is 0, S_CLKOUT[12] is enabled When both bits are 1, S_CLKOUT[12] is disabled
7-6	Clock 3 Disable		If either bit is 0, S_CLKOUT[11] is enabled When both bits are 1, S_CLKOUT[11] is disabled
5-4	Clock 2 Disable		If either bit is 0, S_CLKOUT[10] is enabled When both bits are 1, S_CLKOUT[10] is disabled
3-2	Clock 1 Disable		If either bit is 0, S_CLKOUT[9] is enabled When both bits are 1, S_CLKOUT[9] is disabled
1-0	Clock 0 Disable		If either bit is 0, S_CLKOUT[8] is enabled When both bits are 1, S_CLKOUT[8] is disabled

Note: R/W - Read/Write.



13.2.41 Config Register 1 or 2: Non-Posted Memory Base Register (read/write, bit 15-0; offset 70h)

This register defines the base address of the non-posted memory-mapped address range for forwarding the cycle through the bridge. Upper twelve bits corresponding to address bits [31:20] are read/write. Lower 20 bits (19:0) are assumed to be 00000h.

13.2.42 Config Register 1 or 2: Non-Posted Memory Limit Register (read/write, bit 31-16; offset 70h)

This register defines the upper limit address of the non-posted memory-mapped address range for forwarding the cycle through the bridge. Upper twelve bits corresponding to address bits [31:20] are read/write. Lower 20 bits (19:0) are assumed to be FFFFFFFh.

13.2.43 Configuration Register 1: Port Option Register (bit 15-0; offset 74h)

Bit	Function	Type	Description
15-13	Reserved	R/O	Reset to '000'
12	Primary Pre Read	R/W	Enable 1 more read for MEMR command on primary 1 = Enable 0 = No change
11-10	Reserved	R/O	Reset to '00'
9	Enable Long Request	R/W	Enable Long request for lock cycle 0 = No change 1 = Enable
8	Reset DTQUEUE	R/W	Reset Secondary Delayed Transaction Queue 0 = No change 1 = Reset
7-6	Reserved	R/O	Reset to '00'
5	ID Write Enable	R/W	Allow write to Vendor ID, Device ID, Subsystem Vendor ID and Subsystem ID in the configuration space. 0 = Write protect 1 = Write enable Reset to 0
4	Secondary MEMW Command Alias Enable	R/W	Controls the bridge's detection mechanism for matching non-posted memory write retry cycle from initiator on secondary interface. 0 = Command has to be exact 1 = MEMW is equivalent to MEMWI Reset to 0
3	Secondary MEMR Command Alias Enable	R/W	Controls the bridge's detection mechanism for matching memory read retry cycle from initiator on secondary interface. 0=Command has to be exact 1=MEMR is equivalent to MEMRL or MEMRM Reset to 0
2	Primary MEMW Command Alias Enable	R/W	Controls the bridge's detection mechanism for matching non-posted memory write retry cycle from initiator on primary interface. 0 = Command has to be exact 1 = MEMW is equivalent to MEMWI Reset to 0
1	Primary MEMR Command Alias Enable	R/W	Controls the bridge's detection mechanism for matching memory read retry cycle from initiator on primary interface. 0 = Command has to be exact 1 = MEMR is equivalent to MEMRL or MEMRM Reset to 0
0	Secondary Pre Read	R/W	Enable 1 more read for MEMR command on secondary. 0 = disable 1 = enable Reset to 0



13.2.44 Configuration Register 2: Port Option Register (bit 15-0; offset74h)

Bit	Function	Type	Description
15-13	Reserved	R/O	Reset to '000'
12	Reserved	R/W	Reset to 0
11-10	Reserved	R/O	Reset to '00'
9-8	Reserved	R/W	Reset to '00'
7-6	Reserved	R/O	Reset to '00'
5	ID Write Enable	R/W	Allow write to Vendor ID, Device ID, Subsystem Vendor ID, and Subsystem ID in the configuration space. 0 = Write protect 1 = Write enable Reset to 0
4	Secondary MEMW Command Alias Enable	R/W	Controls the bridge's detection mechanism for matching non-posted memory write retry cycle from initiator on secondary interface. 0 = Command has to be exact 1 = MEMW is equivalent to MEMWI Reset to 0
3	Secondary MEMR Command Alias Enable	R/W	Controls the bridge's detection mechanism for matching memory read retry cycle from initiator on secondary interface. 0=Command has to be exact 1=MEMR is equivalent to MEMRL or MEMRM Reset to 0
2	Reserved	R/W	Reset to 0
1	Reserved	R/W	Reset to 0
0	Secondary Pre Read	R/W	Enable 1 more read for MEMR command on secondary. 0 = disable 1 = enable Reset to 0

**13.2.45 Config Register 1 or 2: Master Timeout Counter Register (read/write, bit 31-16; offset 74h)**

This register holds the maximum number of PCI clocks that PI7C7100 will wait for initiator to retry the same cycle before reporting timeout. Default is 8000h.

13.2.46 Config Register 1 or 2: Retry Counter Register (read/write, bit 31-0; offset 78h)

This register holds the maximum number of attempts that PI7C7100 will try before reporting retry timeout. Default is 0100_0000h.

13.2.47 Config Register 1 or 2: Sampling Timer Register (read/write, bit 31-0; offset 7Ch)

This register set the duration (in PCI clocks) during which PI7C7100 will record the number of successful transactions for performance evaluation. The recording will start right after this register is programmed and will be cleared after the timer expires. The maximum period is 128 seconds. Reset to 0000_0000h.

13.2.48 Config Register 1 or 2: Successful I/O Read Count Register (read/write, bit 31-0; offset 80h)

This register stores the successful I/O read count on the secondary interface which will be updated when the sampling timer is active. Reset to 0000_0000h.

13.2.49 Config Register 1 or 2: Successful I/O Write Count Register (read/write, bit 31-0; offset 84h)

This register stores the successful I/O write count on the secondary interface which will be updated when the sampling timer is active. Reset to 0000_0000h.

13.2.50 Config Register 1 or 2: Successful Memory Read Count Register (read/write, bit 31-0; offset 88h)

This register stores the successful memory read count on the secondary interface which will be updated when the sampling timer is active. Reset to 0000_0000h.

13.2.51 Config Register 1 or 2: Successful Memory Write Count Register (read/write, bit 31-0; offset 8Ch)

This register stores the successful memory write count on the secondary interface which will be updated when the sampling timer is active. Reset to 0000_0000h.

13.2.52 Config Register 1: Primary Successful I/O Read Count Register (read/write, bit 31-0; offset 90h)

This register stores the successful I/O read count on the primary interface which will be updated when the sampling timer is active. Reset to 0000_0000h.

13.2.53 Config Register 1: Primary Successful I/O Write Count Register (read/write, bit 31-0; offset 94h)

This register stores the successful I/O write count on the primary interface which will be updated when the sampling timer is active. Reset to 0000_0000h.

13.2.54 Config Register 1: Primary Successful Memory Read Count Register (read/write, bit 31-0; offset 98h)

This register stores the successful memory read count on the primary interface which will be updated when the sampling timer is active. Reset to 0000_0000h.

13.2.55 Config Register 1: Primary Successful Memory Write Count Register (read/write, bit 31-0; offset 9Ch)

This register stores the successful memory write count on the primary interface which will be updated when the sampling timer is active. Reset to 0000_0000h.

14. Bridge Behavior

A PCI cycle is initiated by asserting the FRAME# signal. In a bridge, there are a number of possibilities. Those possibilities are summarized in the table below:

14.1 Bridge Actions for Various Cycle Types

Initiator	Target	Response
Master on primary	Target on Primary	PI7C7100 does not respond. It detects this situation by decoding the address as well as monitoring the P_DEVSEL# for other fast and medium devices on the primary port.
Master on primary	Target on secondary	PI7C7100 asserts P_DEVSEL#, terminates the cycle normally if it is able to be posted, otherwise returns with a retry. It then passes the cycle to the appropriate port. When the cycle is complete on the target port, it will wait for the initiator to repeat the same cycle and end with normal termination.
Master on primary	Target not on primary nor secondary port	PI7C7100 does not respond and the cycle will terminate as master abort.
Master on secondary	Target on the same secondary port	PI7C7100 does not respond.
Master on secondary	Target on primary or the other secondary port	PI7C7100 asserts S1_DEVSEL# or S2_DEVSEL#, terminates the cycle normally if it is able to be posted, otherwise returns with a retry. It then passes the cycle to the appropriate port. When cycle is complete on the target port, it will wait for the initiator to repeat the same cycle and end with normal termination.
Master on secondary	Target not on primary nor the other secondary	PI7C7100 does not respond.

A target then has up to three cycles to respond before subtractive decoding is initiated. If the target detects an address hit, it should assert its DEVSEL# signal in the cycle corresponding to the values of bits 9 and 10 in the Configuration Status Register.

Termination of a PCI cycle can occur in a number of ways. Normal termination begins by the initiator (master) de-asserting FRAME# with IRDY# being asserted (or remaining asserted) on the same cycle. The cycle completes when TRDY# and IRDY# are both asserted simultaneously. The target should de-assert TRDY# for one cycle following final assertion (sustained 3-state signal).

14.2 Transaction Ordering

To maintain data coherency and consistency, PI7C7100 complies with the ordering rules put forth in the PCI Local Bus Specification, Rev 2.1. The following table summarizes the ordering relationship of all the transactions through the bridge.

- PMW - Posted write (either memory write or memory write & invalidate)
- DRR - Delayed read request (all memory read, I/O read & configuration read)
- DWR - Delayed write request (I/O write & configuration write)
- DRC - Delayed read completion (all memory read, I/O read & configuration read)
- DWC - Delayed write completion (I/O write & configuration write)



Cycle type shown on each row is the subsequent cycle after the previous shown on the column.

Can Row pass Column?	PMW Column 1	DRR Column 2	DWR Column 3	DRC Column 4	DWC Column 5
PMW (Row 1)	No	Yes	Yes	Yes	Yes
DRR (Row 2)	No	No	No	Yes	Yes
DWR (Row 3)	No	No	No	Yes	Yes
DRC (Row 4)	No	Yes	Yes	No	No
DWC (Row 5)	Yes	Yes	Yes	No	No

In Row 1 Column 1, PMW cannot pass the previous PMW and that means they must complete on the target bus in the order in which they were received in the initiator bus.

In Row 2 Column 1, DRR cannot pass the previous PMW and that means the previous PMW heading to the same direction must be completed before the DRR can be attempted on the target bus.

In Row 1 Column 2, PMW can pass the previous DRR as long as the DRR reaches the head of the delayed transaction queue.

14.3 Abnormal Termination (Initiated by Bridge Master)

14.3.1 Master Abort

Master abort indicates that when PI7C7100 acts as a master and receives no response (i.e., no target asserts P_DEVSEL# or S1_DEVSEL# or S2_DEVSEL#) from a target, the bridge de-asserts FRAME# and then de-asserts IRDY#.

14.3.2 Parity and Error Reporting

Parity must be checked for all addresses and write data. Parity is defined on the P_PAR, S1_PAR, and S2_PAR signals. Parity should be even (i.e. an even number of '1's) across AD, CBE, and PAR. Parity information on PAR is valid the cycle after AD and CBE are valid. For reads, even parity must be generated using the initiators CBE signals combined with the read data. Again, the PAR signal corresponds to read data from the previous data phase cycle.

14.3.3 Reporting Parity Errors

For all address phases, if a parity error is detected, the error should be reported on the P_SERR# signal by asserting P_SERR# for one cycle and then 3-stating two cycles after the bad address. P_SERR# can only be asserted if bit 6 and 8 in the Command Register are both set to 1. For write data phases, a parity error should be reported by asserting the P_PERR# signal two cycles after the data phase and should remain asserted for one cycle when bit 8 in the Command register is set to a 1. The target reports any type of data parity errors during write cycles, while the master reports data parity errors during read cycles.

Detection of an address parity error will cause the PCI-to-PCI Bridge target to not claim the bus (P_DEVSEL# remains inactive) and the cycle will then terminate with a Master Abort. When the bridge is acting as master, a data parity error during a read cycle results in the bridge master initiating a Master Abort.

14.3.4 Secondary IDSEL mapping

When PI7C7100 detects a Type 1 configuration transaction for a device connected to the secondary, it translates the Type 1 transaction to Type 0 transaction on the downstream interface. Type 1 configuration format uses a 5-bit field at P_AD[15:11] as a device number. This is translated to S1_AD[31:16] or S2_AD[31:16] by PI7C7100.

15. IEEE 1149.1 Compatible JTAG Controller

An IEEE 1149.1 compatible Test Access Port (TAP) controller and associated TAP pins are provided to support boundary scan in PI7C7100 for board-level continuity test and diagnostics. The TAP pins assigned are TCK, TDI, TDO, TMS and TRST#. All digital input, output, input/output pins are tested except TAP pins and clock pin.

The IEEE 1149.1 Test Logic consists of a TAP controller, an instruction register, and a group of test data registers including Bypass, Device Identification and Boundary Scan registers. The TAP controller is a synchronous 16 state machine driven by the Test Clock (TCK) and the Test Mode Select (TMS) pins. An independent power on reset circuit is provided to ensure the machine is in TEST_LOGIC_RESET state at power-up. The JTAG signal lines are not active when the PCI resource is operating PCI bus cycles.

PI7C7100 implements 3 basic instructions: BYPASS, SAMPLE/PRELOAD, EXTEST.

15.1 Boundary Scan Architecture

Boundary-scan test logic consists of a boundary-scan register and support logic. These are accessed through a Test Access Port (TAP). The TAP provides a simple serial interface that allows all processor signal pins to be driven and/or sampled, thereby providing direct control and monitoring of processor pins at the system level.

This mode of operation is valuable for design debugging and fault diagnosis since it permits examination of connections not normally accessible to the test system. The following subsections describe the boundary-scan test logic elements: TAP pins, instruction register, test data registers and TAP controller. Figure 15-1 illustrates how these pieces fit together to form the JTAG unit.

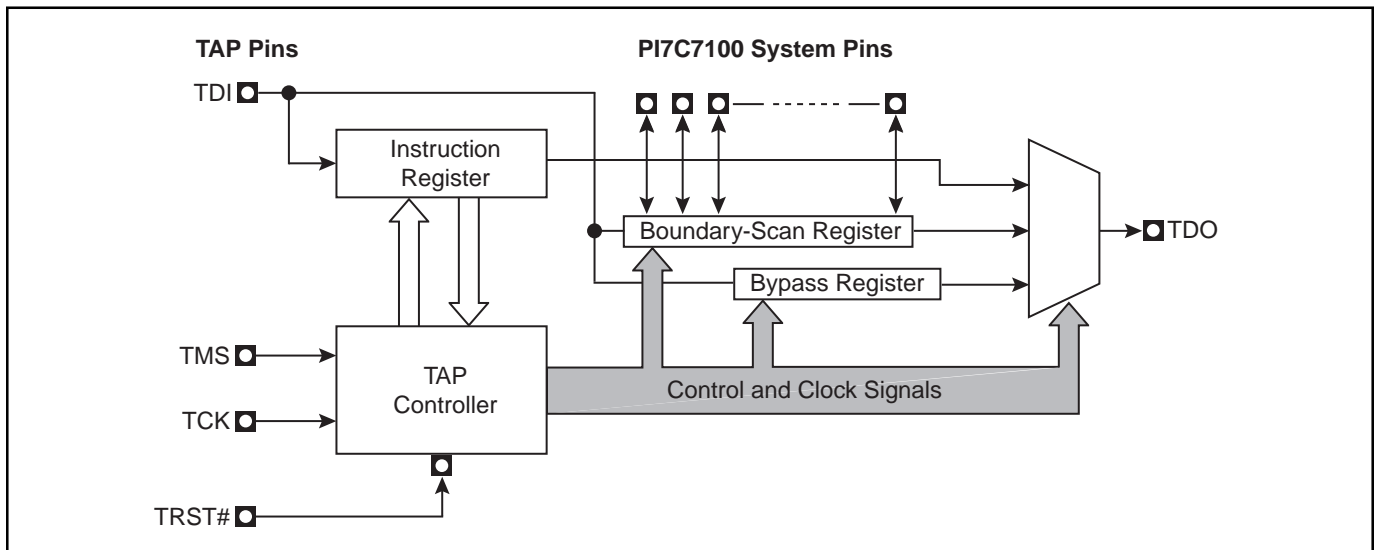

Figure 15-1. Test Access Port Block Diagram

15.1.1 TAP Pins

The PI7C7100's TAP pins form a serial port composed of four input connections (TMS, TCK, TRST# and TDI) and one output connection (TDO). These pins are described in Table 15-1. The TAP pins provide access to the instruction register and the test data registers.

15.1.2 Instruction Register

The Instruction Register (IR) holds instruction codes. These codes are shifted in through the Test Data Input (TDI) pin. The instruction codes are used to select the specific test operation to be performed and the test data register to be accessed.

The instruction register is a parallel-loadable, master/slave-configured 2-bit wide, serial-shift register with latched outputs. Data is shifted into and out of the IR serially through the TDI pin clocked by the rising edge of TCK. The shifted-in instruction becomes active upon latching from the master stage to the slave stage. At that time the IR outputs along with the TAP finite state machine outputs are decoded to select and control the test data register selected by that instruction. Upon latching, all actions caused by any previous instructions terminate.



The instruction determines the test to be performed, the test data register to be accessed, or both. The IR is two bits wide. When the IR is selected, the most significant bit is connected to TDI, and the least significant bit is connected to TDO. The value presented on the TDI pin is shifted into the IR on each rising edge of TCK. The TAP controller captures fixed parallel data (01 binary). When a new instruction is shifted in through TDI, the value 01 (binary) is always shifted out through TDO, least significant bit first. This helps identify instructions in a long chain of serial data from several devices.

Upon activation of the TRST# reset pin, the latched instruction asynchronously changes to the idcode instruction. When the TAP controller moves into the test state other than by reset activation, the opcode changes as TDI shifts, and becomes active on the falling edge of TCK.

15.2 Boundary-Scan Instruction Set

The PI7C7100 supports three mandatory boundary-scan instructions (bypass, sample/preload and extest). The table shown below lists the PI7C7100's boundary-scan instruction codes. The "reserved" code should not be used.

Instruction Code (binary)	Instruction Name	Instruction Code (binary)	Instruction Name
00	extest	10	reserved
01	sample/preload	11	bypass

Table 15-1. TAP Pins

Instruction / Requisite	Opcode (binary)	Description
extest IEEE 1149.1 Required	00	Extest initiates testing of external circuitry, typically board-level interconnects and off chip circuitry. extest connects the boundary-scan register between TDI and TDO. When Extest is selected, all output signal pin values are driven by values shifted into the boundary-scan register and may change only on the falling edge of TCK. Also, when extest is selected, all system input pin states must be loaded into the boundary-scan register on the rising-edge of TCK.
sample/ preload IEEE 1149.1 Required	01	Sample/preload performs two functions: A snapshot of the sample instruction is captured on the rising edge of TCK without interfering with normal operation. The instruction causes boundary-scan register cells associated with outputs to sample the value being driven. • On the falling edge of TCK the data held in the boundary-scan cells is transferred to the slave register cells. Typically the slave latched data is applied to the system outputs via the extest instruction.
idcode IEEE 1149.1 Optional	10	Reserved
bypass IEEE 1149.1 Required	11	Bypass instruction selects the one-bit bypass register between TDI and TDO pins. 0 (binary) is the only instruction that accesses the bypass register. While this instruction is in effect, all other test data registers have no effect on system operation. Test data registers with both test and system functionality perform their system functions when this instruction is selected.

15.3 TAP Test Data Registers

The PI7C7100 contains two test data registers (bypass and boundary-scan). Each test data register selected by the TAP controller is connected serially between TDI and TDO. TDI is connected to the test data register's most significant bit. TDO is connected to the least significant bit. Data is shifted one bit position within the register towards TDO on each rising edge of TCK. While any register is selected, data is transferred from TDI to TDO without inversion. The following sections describe each of the test data registers.

15.4 Bypass Register

The required bypass register, a one-bit shift register, provides the shortest path between TDI and TDO when a bypass instruction is in effect. This allows rapid movement of test data to and from other components on the board. This path can be selected when no test operation is being performed on the PI7C7100.

15.5 Boundary-Scan Register

The boundary-scan register contains a cell for each pin as well as control cells for I/O and the high-impedance pin.

Table 15-2 shows the bit order of the PI7C7100 boundary-scan register. All table cells that contain "Control" select the direction of bidirectional pins or high-impedance output pins. When a "0" is loaded into the control cell, the associated pin(s) are high-impedance or selected as input.

The boundary-scan register is a required set of serial-shiftable register cells, configured in master/slave stages and connected between each of the PI7C7100's pins and on-chip system logic. The VDD, GND, PLL, AGND, AVDD and JTAG pins are NOT in the boundary-scan chain.

The boundary-scan register cells are dedicated logic and do not have any system function. Data may be loaded into the boundary-scan register master cells from the device input pins and output pin-drivers in parallel by the mandatory sample/preload and extest instructions. Parallel loading takes place on the rising edge of TCK.

Data may be scanned into the boundary-scan register serially via the TDI serial input pin, clocked by the rising edge of TCK. When the required data has been loaded into the master-cell stages, it can be driven into the system logic at input pins or onto the output pins on the falling edge of TCK state. Data may also be shifted out of the boundary-scan register by means of the TDO serial output pin at the falling edge of TCK.

15.6 TAP Controller

The TAP (Test Access Port) controller is a 4-state synchronous finite state machine that controls the sequence of test logic operations. The TAP can be controlled via a bus master. The bus master can be either automatic test equipment or a component (i.e., PLD) that interfaces to the TAP. The TAP controller changes state only in response to a rising edge of TCK. The value of the test mode state (TMS) input signal at a rising edge of TCK controls the sequence of state changes. The TAP controller is initialized after power-up by applying a low to the TRST# pin. In addition, the TAP controller can be initialized by applying a high signal level on the TMS input for a minimum of five TCK periods.

For greater detail on the behavior of the TAP controller, test logic in each controller state and the state machine and public instructions, refer to the IEEE 1149.1 Standard Test Access Port and Boundary-Scan Architecture document (available from the IEEE).



ADVANCE INFORMATION

PI7C7100
3-Port PCI Bridge

Table 15-2. JTAG Boundary Register Order

Order	Pin Names	Type
1	S2_AD[20-31]	control enable
2	S2_AD[21]	output
3	S2_AD[21]	input
4	S2_PERR#	control enable
5	S2_PERR#	output
6	S2_PERR#	input
7	S2_AD[8-19]	control enable
8	S2_AD[16]	output
9	S2_AD[16]	input
10	S2_FRAME#	control enable
11	S2_FRAME#	output
12	S2_FRAME#	input
13	S2_DEVSEL#/S2_TRDY#	control enable
14	S2_DEVSEL#	output
15	S2_DEVSEL#	input
16	S2_AD[19]	output
17	S2_AD[19]	input
18	S2_AD[17]	output
19	S2_AD[17]	input
20	S2_AD[18]	output
21	S2_AD[18]	input
22	S2_AD[20]	output
23	S2_AD[20]	input
24	S2_AD[22]	output
25	S2_AD[22]	input
26	S2_AD[24]	output
27	S2_AD[24]	input
28	S2_AD[23]	output
29	S2_AD[23]	input
30	S2_CBE[0-3]	control enable
31	S2_CBE[3]	output
32	S2_CBE[3]	input
33	S2_AD[25]	output
34	S2_AD[25]	input
35	S2_AD[26]	output

Order	Pin Names	Type
36	S2_AD[26]	input
37	S2_AD[28]	output
38	S2_AD[28]	input
39	S2_AD[27]	output
40	S2_AD[27]	input
41	S2_AD[29]	output
42	S2_AD[29]	input
43	S2_AD[30]	output
44	S2_AD[30]	input
45	S2_AD[31]	output
46	S2_AD[31]	input
47	S2_GNT[0]#	control enable
48	S2_GNT[0]#	output
49	S2_REQ[0]#	input
50	S2_REQ[1]#	input
51	S2_GNT[1]#	output
52	S2_GNT[2]#	output
53	S2_REQ[2]#	input
54	S2_REQ[3]#	input
55	S2_GNT[3]#	output
56	S2_GNT[4]#	output
57	S2_REQ[4]#	input
58	S2_REQ[5]#	input
59	S2_GNT[5]#	output
60	S2_GNT[6]#	output
61	S2_REQ[6]#	input
62	S2_REQ[7]#	input
63	S2_GNT[7]#	output
64	S2_RESET#	output
65	S_CFN#	input
66	S1_EN#	input
67	S2_EN#	input
68	SCAN_TM#	input
69	SCAN_EN	input
70	PLL_TM	input

Order	Pin Names	Type
71	BYPASS	input
72	FLUSH#	input
73	P_RESET#	input
74	P_GNT#	input
75	P_REQ#	control enable
76	P_REQ#	output
77	P_AD[20-31]	control enable
78	P_AD[30]	output
79	P_AD[30]	input
80	P_AD[31]	output
81	P_AD[31]	input
82	P_AD[27]	output
83	P_AD[27]	input
84	P_AD[26]	output
85	P_AD[26]	input
86	P_AD[28]	output
87	P_AD[28]	input
88	P_AD[29]	output
89	P_AD[29]	input
90	P_CBE[0-3]	control enable
91	P_CBE[3]	output
92	P_CBE[3]	input
93	P_AD[24]	output
94	P_AD[24]	input
95	P_AD[25]	output
96	P_AD[25]	input
97	P_AD[23]	output
98	P_AD[23]	input
99	P_AD[22]	output
100	P_AD[22]	input
101	P_IDSEL	input
102	P_AD[21]	output
103	P_AD[21]	input
104	P_AD[20]	output
105	P_AD[20]	input



ADVANCE INFORMATION

PI7C7100
3-Port PCI Bridge

Table 15-2. JTAG Boundary Register Order (continued)

Order	Pin Names	Type
106	P_AD[8-19]	control enable
107	P_AD[19]	output
108	P_AD[19]	input
109	P_AD[18]	output
110	P_AD[18]	input
111	P_AD[17]	output
112	P_AD[17]	input
113	P_AD[16]	output
114	P_AD[16]	input
115	P_CBE[2]	output
116	P_CBE[2]	input
117	P_FRAME#	control enable
118	P_FRAME#	output
119	P_FRAME#	input
120	P_IRDY#	control enable
121	P_IRDY#	output
122	P_IRDY#	input
123	P_DEVSEL/P_TRDY#	control enable
124	P_TRDY#	output
125	P_TRDY#	input
126	P_DEVSEL#	output
127	P_DEVSEL#	input
128	P_STOP#	control enable
129	P_STOP#	output
130	P_STOP#	input
131	P_PERR#	control enable
132	P_PERR#	output
133	P_PERR#	input
134	P_LOCK#	control enable
135	P_LOCK#	output
136	P_LOCK#	input
137	P_SERR#	control enable
138	P_SERR#	output
139	P_AD[13]	output
140	P_AD[13]	input

Order	Pin Names	Type
141	P_AD[14]	output
142	P_AD[14]	input
143	P_AD[11]	output
144	P_AD[11]	input
145	P_AD[15]	output
146	P_AD[15]	input
147	P_AD[12]	output
148	P_AD[12]	input
149	P_AD[8]	output
150	P_AD[8]	input
151	P_CBE[1]	output
152	P_CBE[1]	input
153	P_AD[9]	output
154	P_AD[9]	input
155	P_AD[0-7]	control enable
156	P_AD[5]	output
157	P_AD[5]	input
158	P_M66EN	input
159	P_AD[6]	output
160	P_AD[6]	input
161	P_AD[2]	output
162	P_AD[2]	input
163	P_PAR	control enable
164	P_PAR	output
165	P_PAR	input
166	P_AD[0]	output
167	P_AD[0]	input
168	P_CBE[0]	output
169	P_CBE[0]	input
170	P_AD[7]	output
171	P_AD[7]	input
172	P_AD[10]	output
173	P_AD[10]	input
174	P_AD[1]	output
175	P_AD[1]	input

Order	Pin Names	Type
176	P_AD[3]	output
177	P_AD[3]	input
178	P_AD[4]	output
179	P_AD[4]	input
180	S1_AD[0-7]	control enable
181	S1_AD[0]	output
182	S1_AD[0]	input
183	S1_AD[1]	output
184	S1_AD[1]	input
185	S1_AD[2]	output
186	S1_AD[2]	input
187	S1_AD[5]	output
188	S1_AD[5]	input
189	S1_AD[3]	output
190	S1_AD[3]	input
191	S1_AD[4]	output
192	S1_AD[4]	input
193	S1_CBE[0-3]	control enable
194	S1_CBE[0]	output
195	S1_CBE[0]	input
196	S1_AD[7]	output
197	S1_AD[7]	input
198	S1_AD[6]	output
199	S1_AD[6]	input
200	S1_AD[8-19]	control enable
201	S1_AD[8]	output
202	S1_AD[8]	input
203	S1_AD[9]	output
204	S1_AD[9]	input
205	S1_AD[10]	output
206	S1_AD[10]	input
207	S1_AD[11]	output
208	S1_AD[11]	input
209	S1_AD[12]	output
210	S1_AD[12]	input



Table 15-2. JTAG Boundary Register Order (continued)

Order	Pin Names	Type
211	S1_AD[14]	output
212	S1_AD[14]	input
213	S1_AD[13]	output
214	S1_AD[13]	input
215	S1_AD[15]	output
216	S1_AD[15]	input
217	S1_SERR#	input
218	S1_PAR	control enable
219	S1_PAR	output
220	S1_PAR	input
221	S1_CBE[1]	output
222	S1_CBE[1]	input
223	S1_DEVSEL#/S1_TRDY#	control enable
224	S1_DEVSEL#	output
225	S1_DEVSEL#	input
226	S1_STOP#	control enable
227	S1_STOP#	output
228	S1_STOP#	input
229	S1_LOCK#	control enable
230	S1_LOCK#	output
231	S1_LOCK#	input
232	S1_PERR#	control enable
233	S1_PERR#	output
234	S1_PERR#	input
235	S1_FRAME#	control enable
236	S1_FRAME#	output
237	S1_FRAME#	input
238	S1_IRDY#	control enable
239	S1_IRDY#	output
240	S1_IRDY#	input
241	S1_TRDY#	output
242	S1_TRDY#	input
243	S1_AD[17]#	output
244	S1_AD[17]#	input
245	S1_AD[16]#	output

Order	Pin Names	Type
246	S1_AD[16]#	input
247	S1_AD[20-31]	control enable
248	S1_AD[20]	output
249	S1_AD[20]	input
250	S1_CBE[2]	output
251	S1_CBE[2]	input
252	S1_AD[19]	output
253	S1_AD[19]	input
254	S1_CBE[3]	output
255	S1_CBE[3]	input
256	S1_AD[23]	output
257	S1_AD[23]	input
258	S1_AD[26]	output
259	S1_AD[26]	input
260	S1_AD[22]	output
261	S1_AD[22]	input
262	S1_AD[25]	output
263	S1_AD[25]	input
264	S1_AD[29]	output
265	S1_AD[29]	input
266	S1_AD[21]	output
267	S1_AD[21]	input
268	S1_AD[28]	output
269	S1_AD[28]	input
270	S1_AD[30]	output
271	S1_AD[30]	input
272	S1_AD[31]	output
273	S1_AD[31]	input
274	S1_AD[27]	output
275	S1_AD[27]	input
276	S1_AD[24]	output
277	S1_AD[24]	input
278	S1_AD[18]	output
279	S1_AD[18]	input
280	S1_GNT[0]#	control enable

Order	Pin Names	Type
281	S1_GNT[0]#	output
282	S1_REQ[0]#	input
283	S1_REQ[1]#	input
284	S1_GNT[1]#	output
285	S1_GNT[2]#	output
286	S1_REQ[2]#	input
287	S1_REQ[3]#	input
288	S1_GNT[3]#	output
289	S1_GNT[4]#	output
290	S1_REQ[4]#	input
291	S1_REQ[5]#	input
292	S1_GNT[5]#	output
293	S1_GNT[6]#	output
294	S1_REQ[6]#	input
295	S1_REQ[7]#	input
296	S1_GNT[7]#	output
297	S1_RESET#	output
298	S2_AD[0-7]	control enable
299	S2_AD[0]	output
300	S2_AD[0]	input
301	S2_AD[1]	output
302	S2_AD[1]	input
303	S2_AD[2]	output
304	S2_AD[2]	input
305	S2_AD[3]	output
306	S2_AD[3]	input
307	S2_AD[4]	output
308	S2_AD[4]	input
309	S2_AD[5]	output
310	S2_AD[5]	input
311	S2_AD[6]	output
312	S2_AD[6]	input
313	S2_AD[7]	output
314	S2_AD[7]	input
315	S2_CBE[0]	output



Table 15-2. JTAG Boundary Register Order (continued)

Order	Pin Names	Type
316	S2_CBE[0]	input
317	S2_AD[8]	output
318	S2_AD[8]	input
319	S2_AD[10]	output
320	S2_AD[10]	input
321	S2_AD[9]	output
322	S2_AD[9]	input
323	S2_AD[11]	output
324	S2_AD[11]	input
325	S_M66EN	input
326	S2_AD[12]	output
327	S2_AD[12]	input
328	S2_AD[14]	output
329	S2_AD[14]	input
330	S2_CBE[1]	output
331	S2_CBE[1]	input
332	S2_AD[15]	output
333	S2_AD[15]	input
334	S2_PAR	control enable

Order	Pin Names	Type
335	S2_PAR	output
336	S2_PAR	input
337	S2_SERR#	input
338	S2_LOCK#	control enable
339	S2_LOCK#	output
340	S2_LOCK#	input
341	S2_TRDY#	output
342	S2_TRDY#	input
343	S2_STOP#	control enable
344	S2_STOP#	output
345	S2_STOP#	input
346	S2_IRDY#	control enable
347	S2_IRDY#	output
348	S2_IRDY#	input
349	S2_CBE[2]	output
350	S2_CBE[2]	input
351	S2_AD[13]	output
352	S2_AD[13]	input



16. Electrical and Timing Specifications

16.1 Maximum Ratings

(Above which the useful life may be impaired. For user guidelines, not tested).

Storage Temperature	-65°C to +150°C
Ambient Temperature with Power applied	0°C to +70°C
Supply Voltage to Ground Potentials (Inputs & AV _{CC} , V _{DD} only)	-0.3V to +3.6V
DC Input Voltage	-0.5V to +3.6V

Note:

Stresses greater than those listed under MAXIMUM RATINGS may cause permanent damage to the device. This is a stress rating only and functional operation of the device at these or any conditions above those indicated in the operational sections of this specification is not implied. Exposure to absolute maximum rating conditions for extended periods of time may affect reliability.

16.2 3.3V DC Specifications

Symbol	Parameter	Condition	Min.	Max.	Units	Notes
V _{DD} , AV _{CC}	Supply Voltage		3	3.6	V	3
V _{ih}	Input HIGH Voltage		0.5 V _{DD}	V _{DD} + 0.5		
V _{il}	Input LOW Voltage		-0.5	0.3 V _{DD}		
V _{ih}	CMOS Input HIGH Voltage		0.7 V _{DD}	V _{DD} + 0.5		
V _{il}	CMOS Input LOW Voltage		-0.5	0.3 V _{DD}		
V _{ipu}	Input Pull-up Voltage		0.7 V _{DD}		μA	3
I _{ij}	Input Leakage Current	0 < V _{in} < V _{DD}		±10		
V _{oh}	Output HIGH Voltage	I _{out} = -500μA	0.9 V _{DD}			
V _{ol}	Output LOW Voltage	I _{out} = 1500μA		0.1 V _{DD}		
V _{oh}	CMOS Output HIGH Voltage	I _{out} = -500μA	V _{DD} -0.5		V	2
V _{ol}	CMOS Output LOW Voltage	I _{out} = 1500μA		0.5		
C _{in}	Input Pin Capacitance			10	pF	3
C _{clk}	CLK Pin Capacitance		5	12		
C _{IDSEL}	IDSEL Pin Capacitance			8		
L _{pin}	Pin Inductance			20		
					nH	

Notes:

1. CMOS Input pins: S_CFN#, TCK, TMS, TDI, TRST#, SCAN_EN, SCAN_TM#
2. CMOS Output pin: TDO
3. PCI pins: P_AD[31:0], P_CBE[3:0], P_PAR, P_FRAME#, P_IRDY#, P_TRDY#, P_DEVSEL#, P_STOP#, P_LOCK#, PIDSEL#, P_PERR#, P_SERR#, P_REQ#, P_GNT#, P_RESET#, S1_AD[31:0], S2_AD[31:0], S1_CBE[3:0], S2_CBE[3:0], S1_PAR, S2_PAR, S1_FRAME#, S2_FRAME#, S1_IRDY#, S2_IRDY#, S1_TRDY#, S2_TRDY#, S1_DEVSEL#, S2_DEVSEL#, S1_STOP#, S2_STOP#, S1_LOCK#, S2_LOCK#, S1_PERR#, S2_PERR#, S1_SERR#, S2_SERR#, S1_REQ[7:0]#, S2_REQ[7:0]#, S1_GNT[7:0]#, S2_GNT[7:0], S1_RESET#, S2_RESET#, S1_EN, S2_EN, P_FLUSH#.

16.3 3.3V AC Specifications

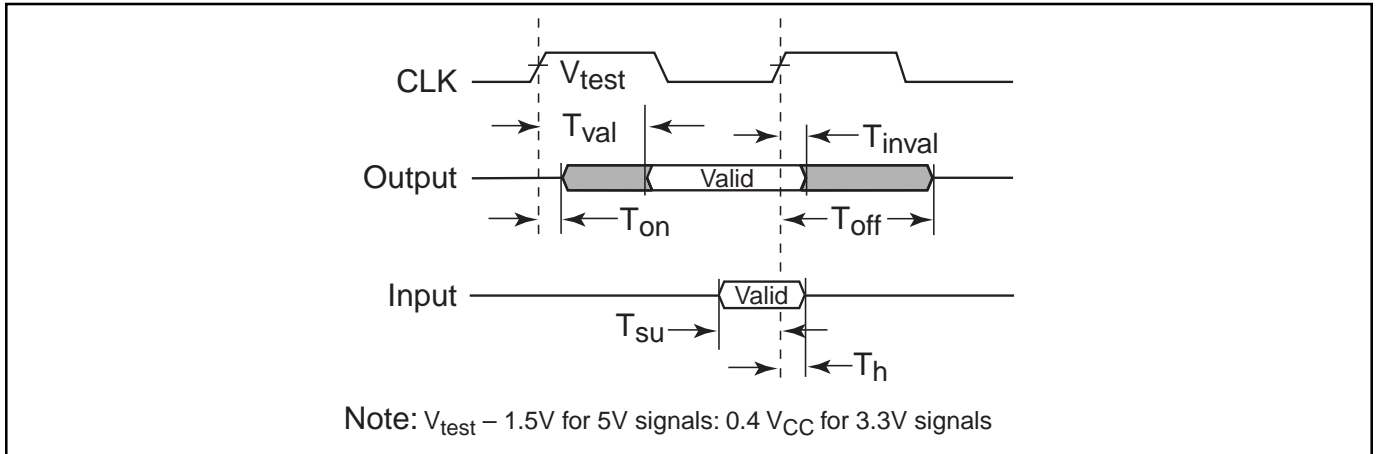

Figure 16-1. PCI Signal Timing Measurement Conditions

Symbol	Parameter	Min.	Max.	Units
T_{su}	Input setup time to CLK - based signals ^{1,2,3}	7	–	ns
$T_{su(ptp)}$	Input setup time to CLK - point-to-point ^{1,2,3}	10, 12	–	
T_h	Input signal hold time from CLK ^{1,2}	0	–	
T_{val}	CLK to signal valid delay - based signals ^{1,2,3}	2	11	
$T_{val(ptp)}$	CLK to signal valid delay - point-to-point ^{1,2,3}	2	12	
T_{on}	Float to active delay ^{1,2}	2	–	
T_{off}	Active to float delay ^{1,2}	–	28	

- See Figure 16-1 PCI Signal Timing Measurement Conditions.
- All primary interface signals are synchronized to P_CLK. All secondary interface signals are synchronized to S_CLKOUT.
- Point-to-point signals are p_req#, s1_req#<7:0>, s2_req#<7:0>, p_gnt#, s1_gnt#<7:0>, and s2_gnt#<7:0>. Based signals are p_ad, p_cbe#, p_par, p_perr#, p_serr#, p_frame#, p_irdy#, p_trdy#, p_lock#, p_devsel#, p_stop#, p_idsel, s1_ad, s1_cbe#, s1_par, s1_perr#, s1_serr#, s1_frame#, s1_irdy#, s1_trdy#, s1_lock#, s1_devsel#, s1_stop#, s2_ad, s2_cbe#, s3_par, s2_perr#, s2_serr#, s2_frame#, s2_irdy#, s2_trdy#, s2_lock#, s2_devsel#, and s2_stop#.

16.4 Primary and Secondary Buses at 33 MHz Clock Timing

Symbol	Parameter	Condition	Min.	Max.	Units
T_{SKEW}	SKEW among S_CLKOUT[15:0]		0	1.0	ns
T_{DELAY}	DELAY between PCLK and S_CLKOUT[15:0]	20pF load	7	10	
T_{CYCLE}	PCLK, S_CLKOUT[15:0] cycle time		30		
T_{HIGH}	PCLK, S_CLKOUT[15:0] HIGH time		11		
T_{LOW}	PCLK, S_CLKOUT[15:0] LOW time		11		

16.5 Power Consumption

Parameter	Typical	Units
Power Consumption	600	mW
Supply Current, I_{CC}	182	mA

17. 256-Pin PBGA Package

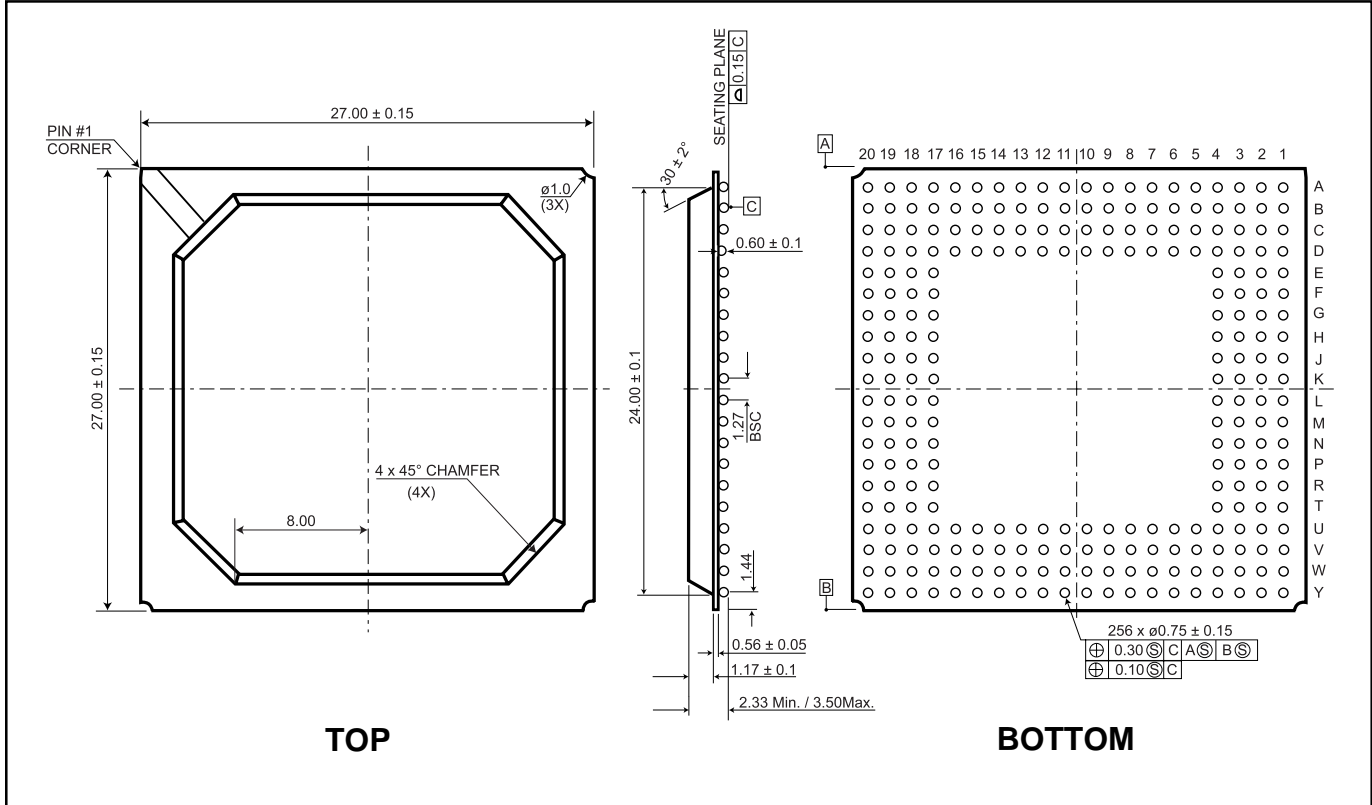

Figure 17-1. 256-Pin PBGA Package

17.1 Part Number Ordering Information

Part	Pin - Package	Temperature
PI7C7100CNA	256 - PBGA	0°C to $+70^\circ\text{C}$



ADVANCE INFORMATION

PI7C7100
3-Port PCI Bridge



PI7C7100 3-Port PCI Bridge

Appendix A

Timing Diagrams



ADVANCE INFORMATION

Appendix A
PI7C7100
3-Port PCI Bridge



Figure 1. Configuration Read Transaction

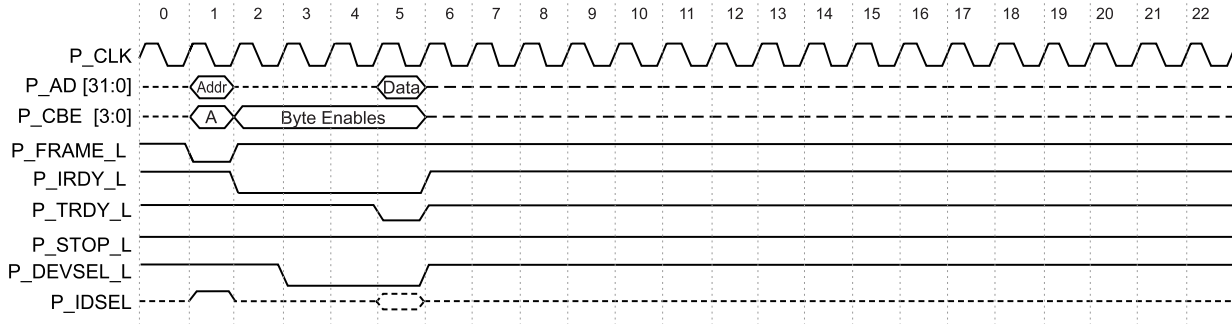

Figure 2. Configuration Write Transaction

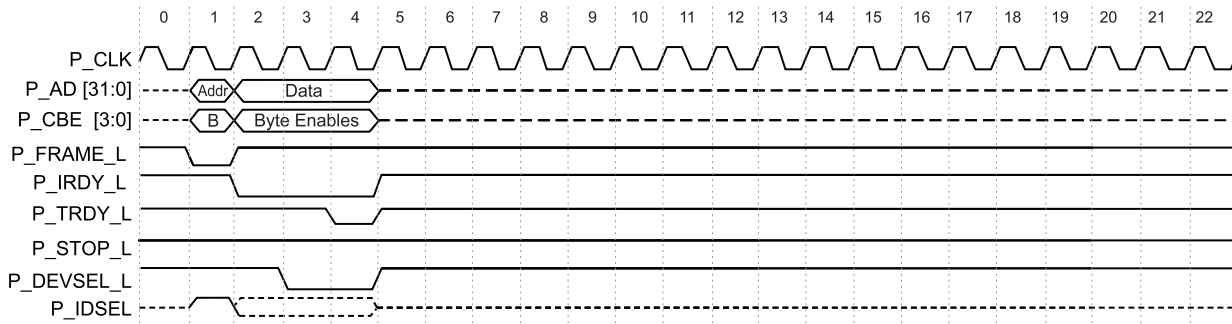

Figure 3. Type 1 to Type 0 Configuration Read Transaction (P --> S)

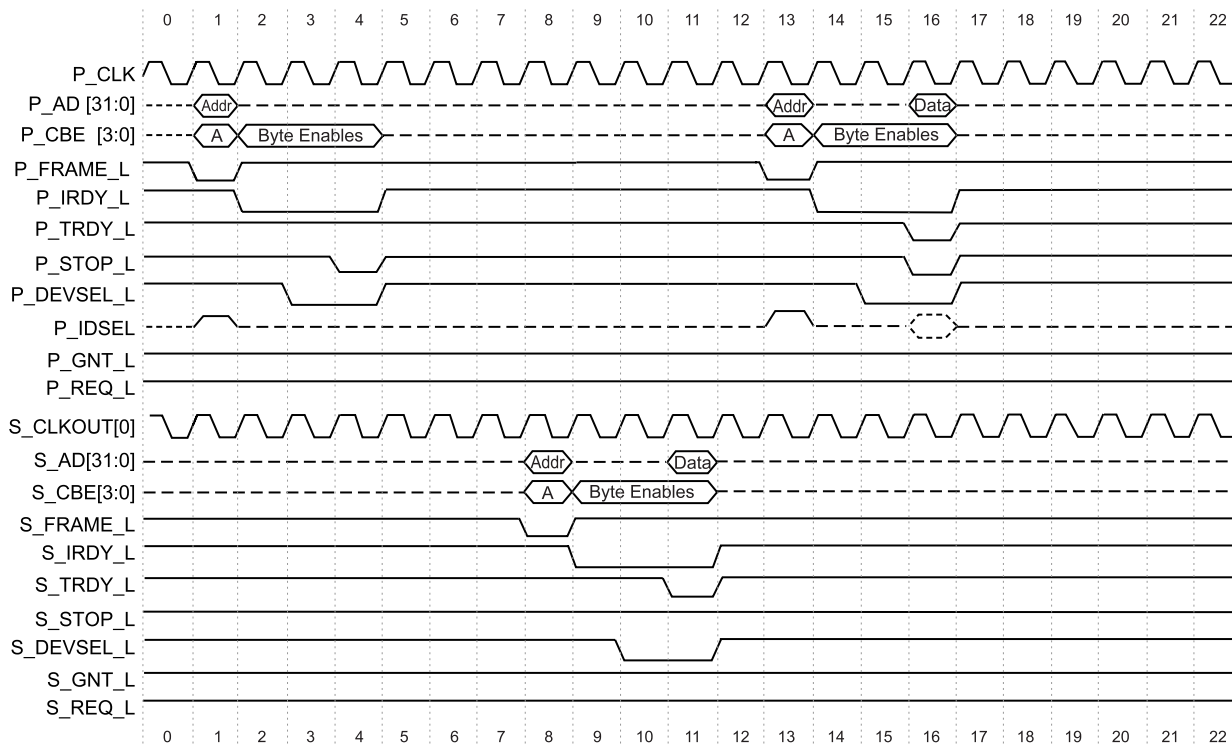

Figure 4. Type 1 to Type 0 Configuration Write Transaction (P --> S)

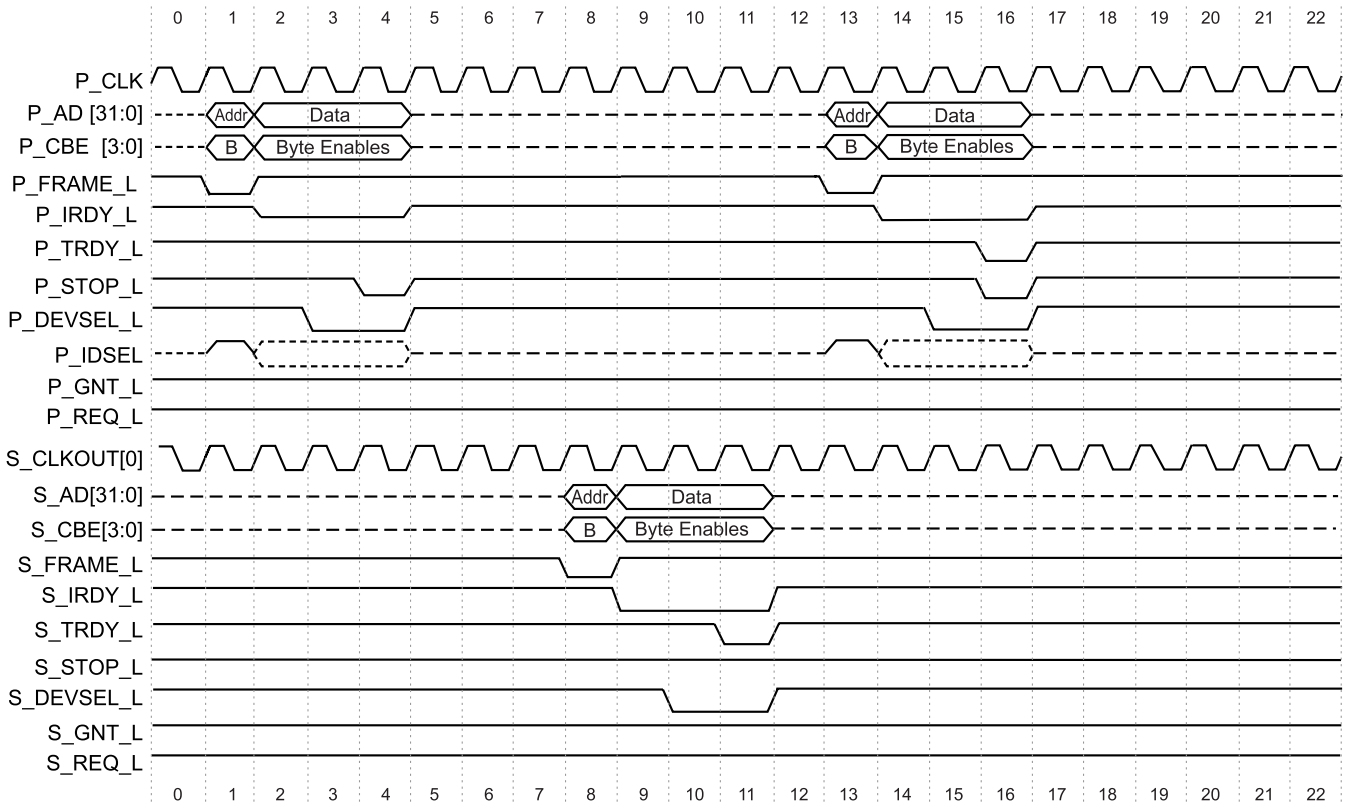

Figure 5. Upstream Type 1 to Special Cycle Transaction (S --> P)

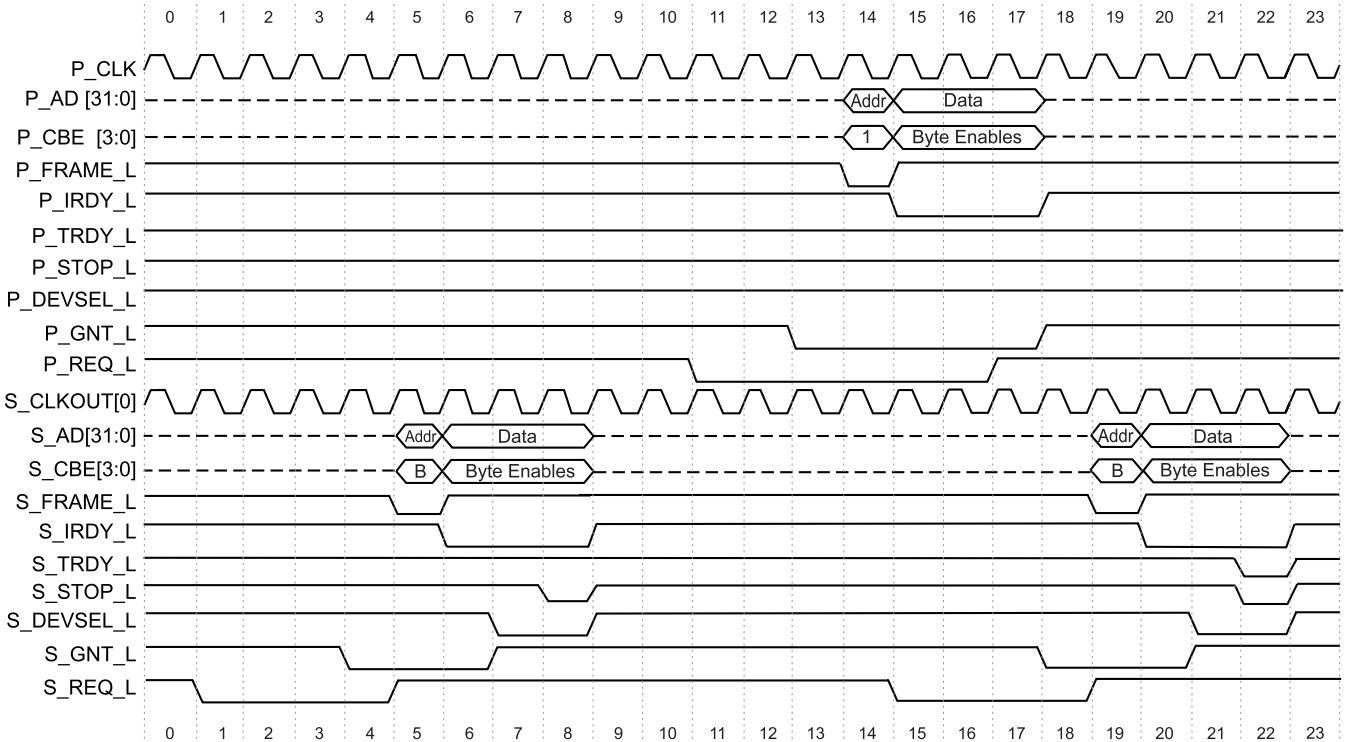

Figure 6. Downstream Type 1 to Special Cycle Transaction (P --> S)

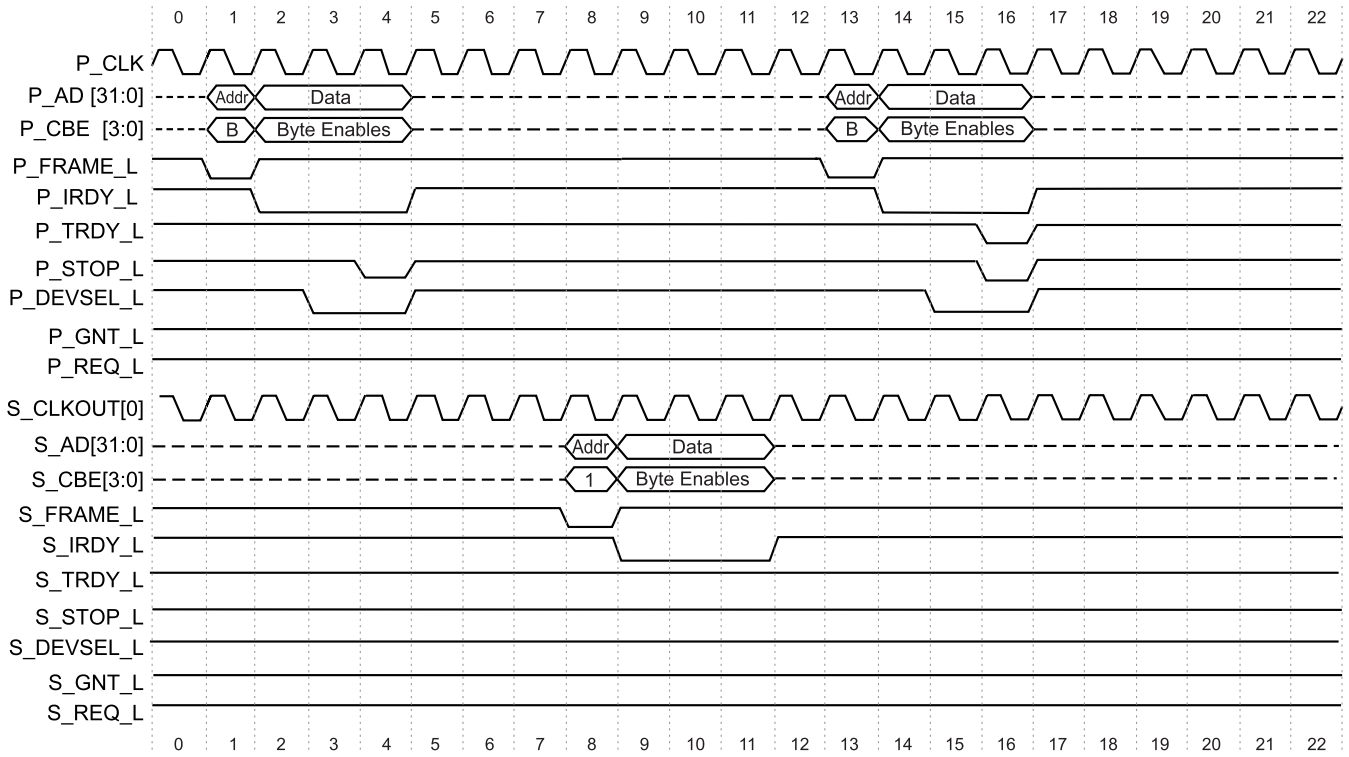
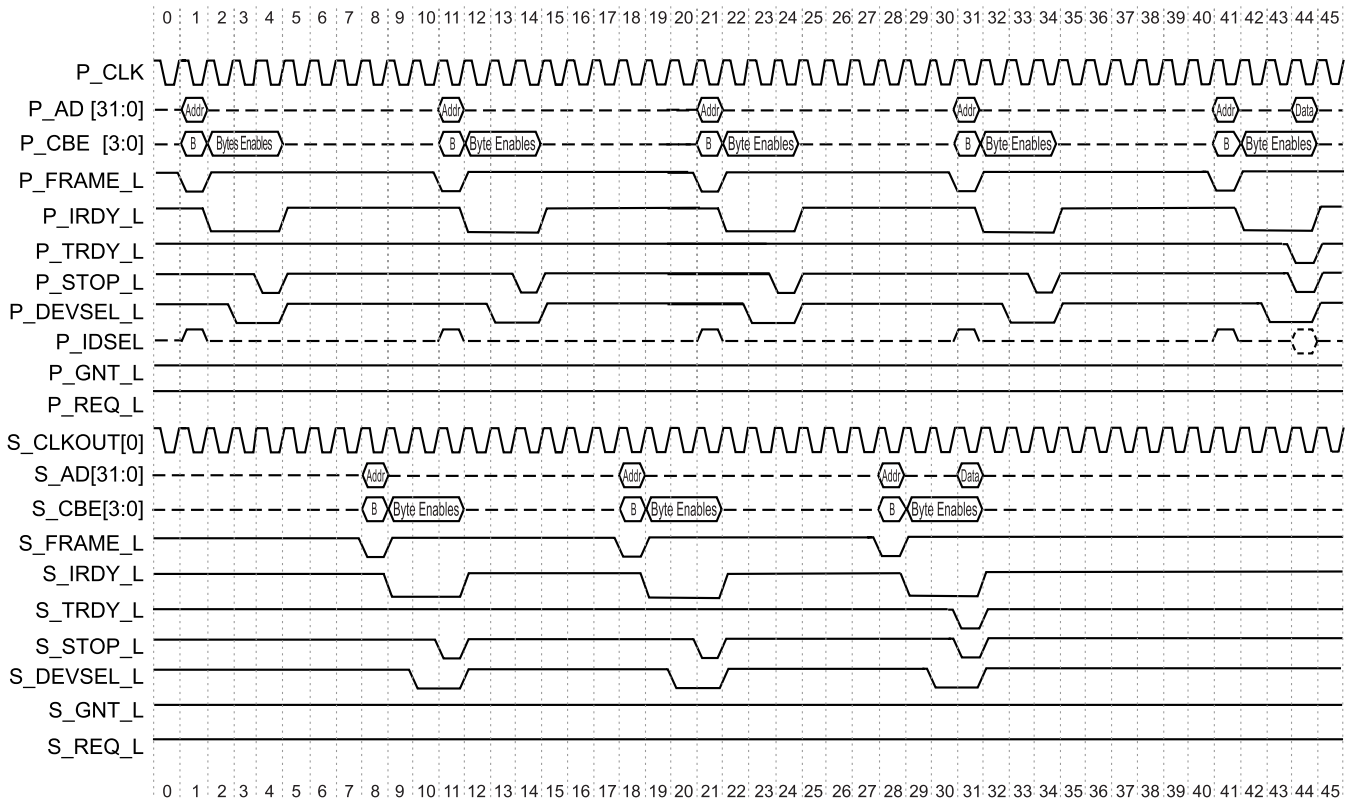

Figure 7. Downstream Type1 to Type1 Configuration Read Transaction (P --> S)





ADVANCE INFORMATION

Appendix A PI7C7100 3-Port PCI Bridge

Figure 8. Downstream Type1 to Type1 Configuration Write Transaction (P --> S)

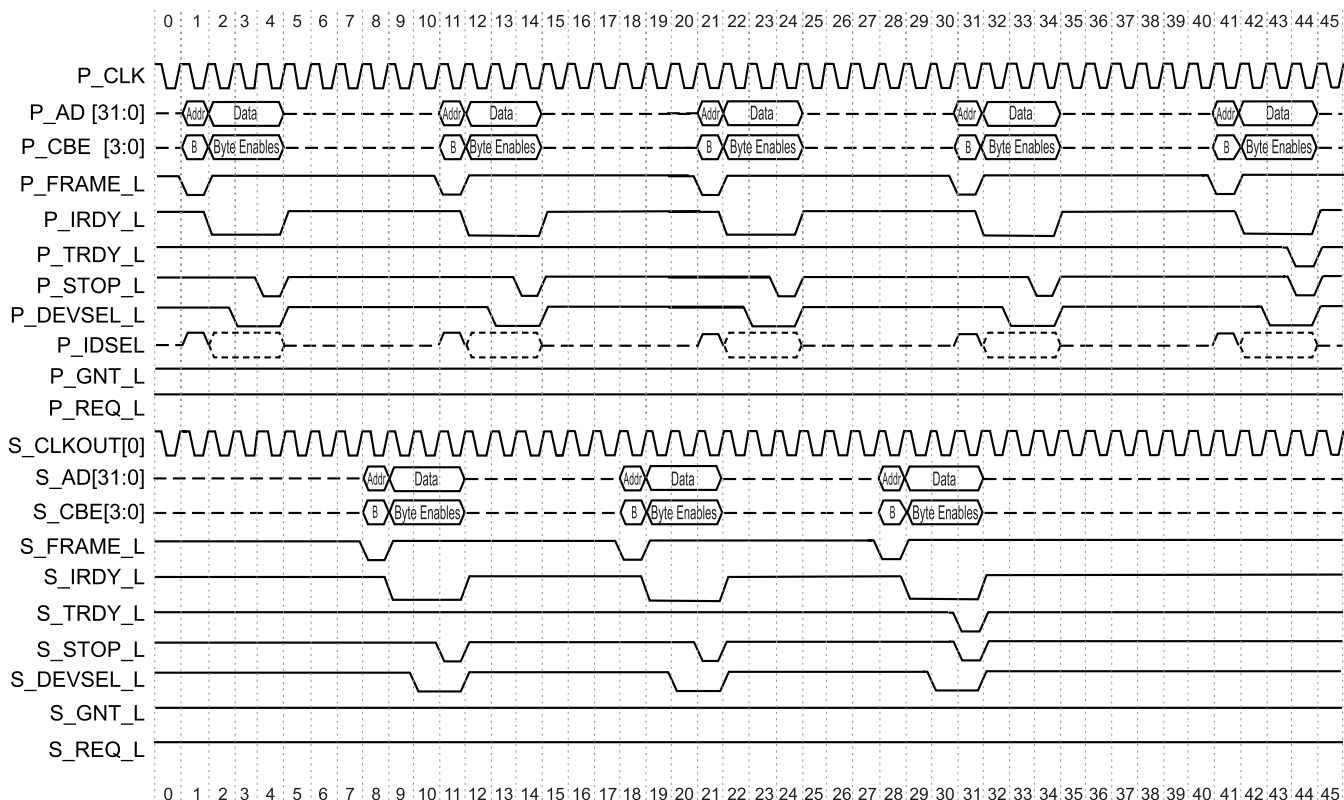

Figure 9. Upstream Delayed Burst Memory Read Transaction (S --> P)

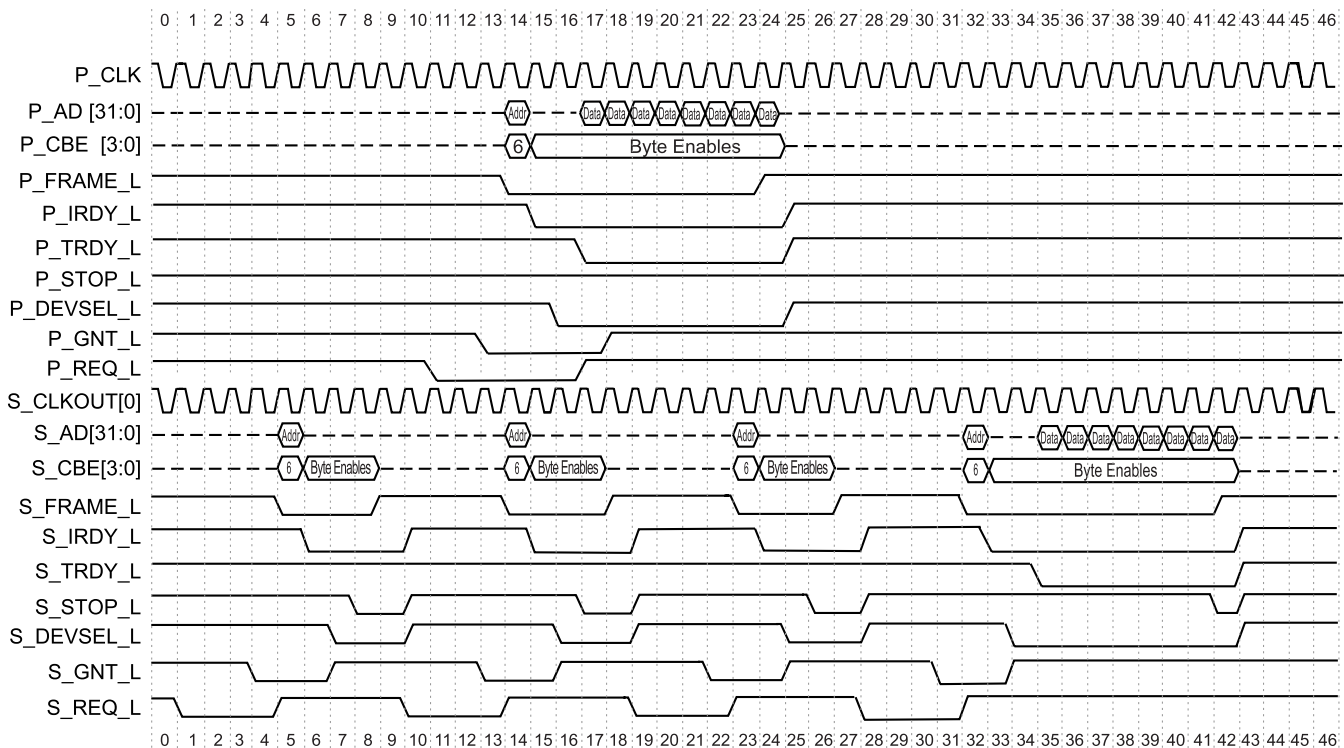

Figure 10. Downstream Delayed Burst Memory Read Transaction (P --> S)

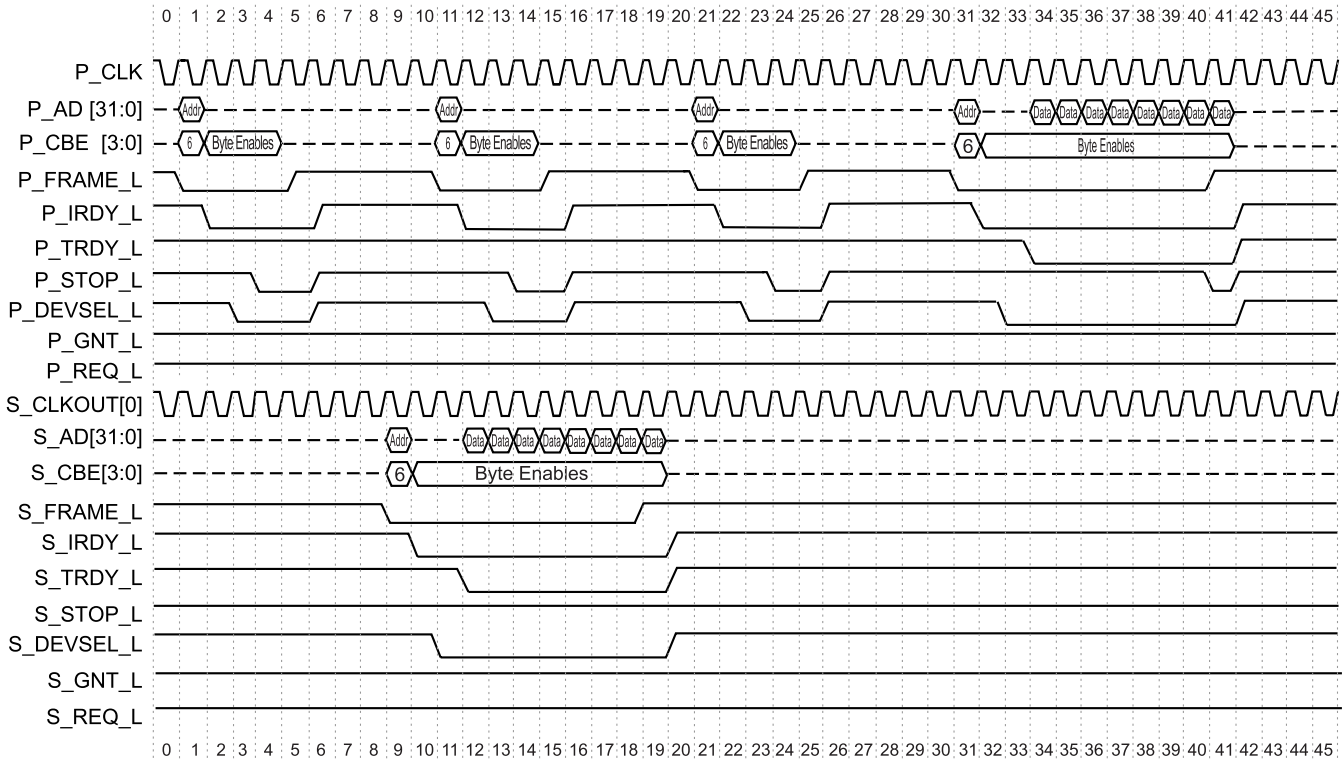
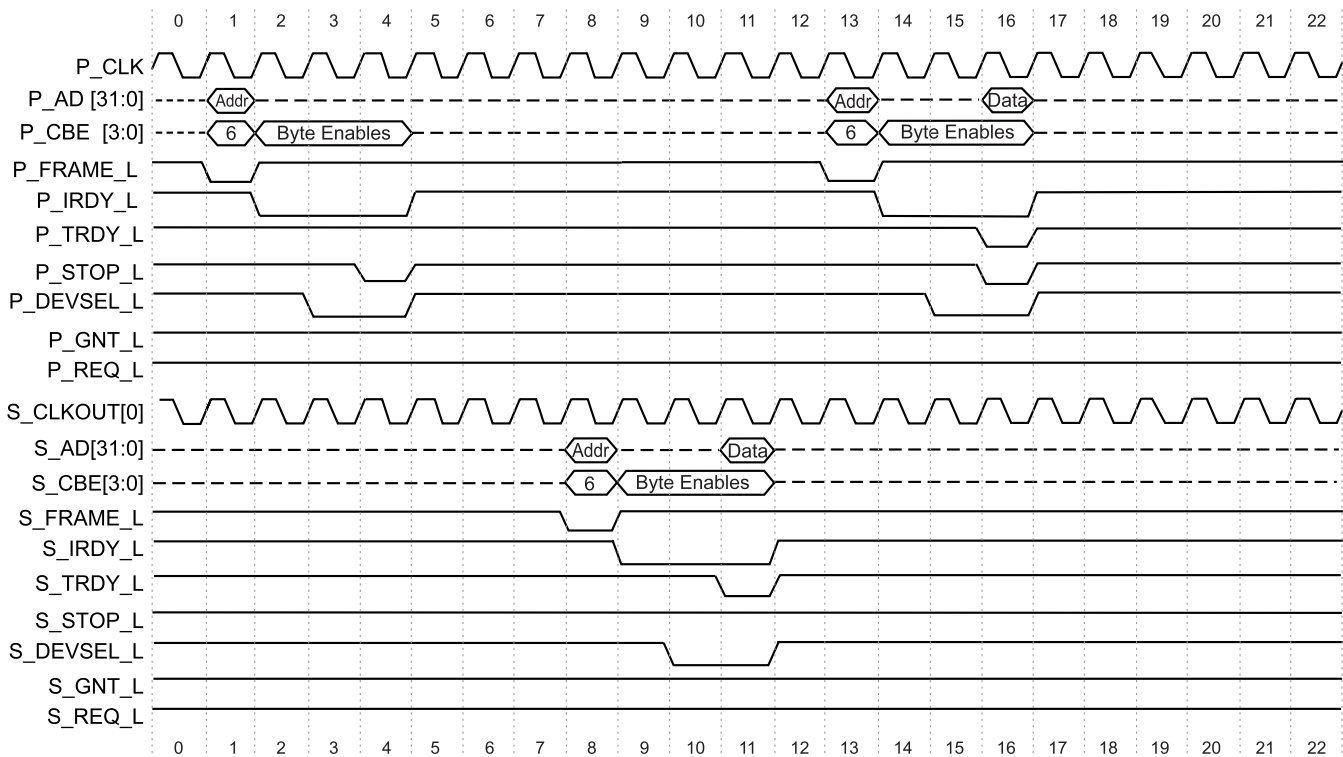

Figure 11. Downstream Delayed Memory Read Transaction (P/33MHz-->S/33MHz)





ADVANCE INFORMATION

Appendix A
PI7C7100
3-Port PCI Bridge

Figure 12. Downstream Delayed Memory Read Transaction (S2/33MHz-->S1/33MHz)

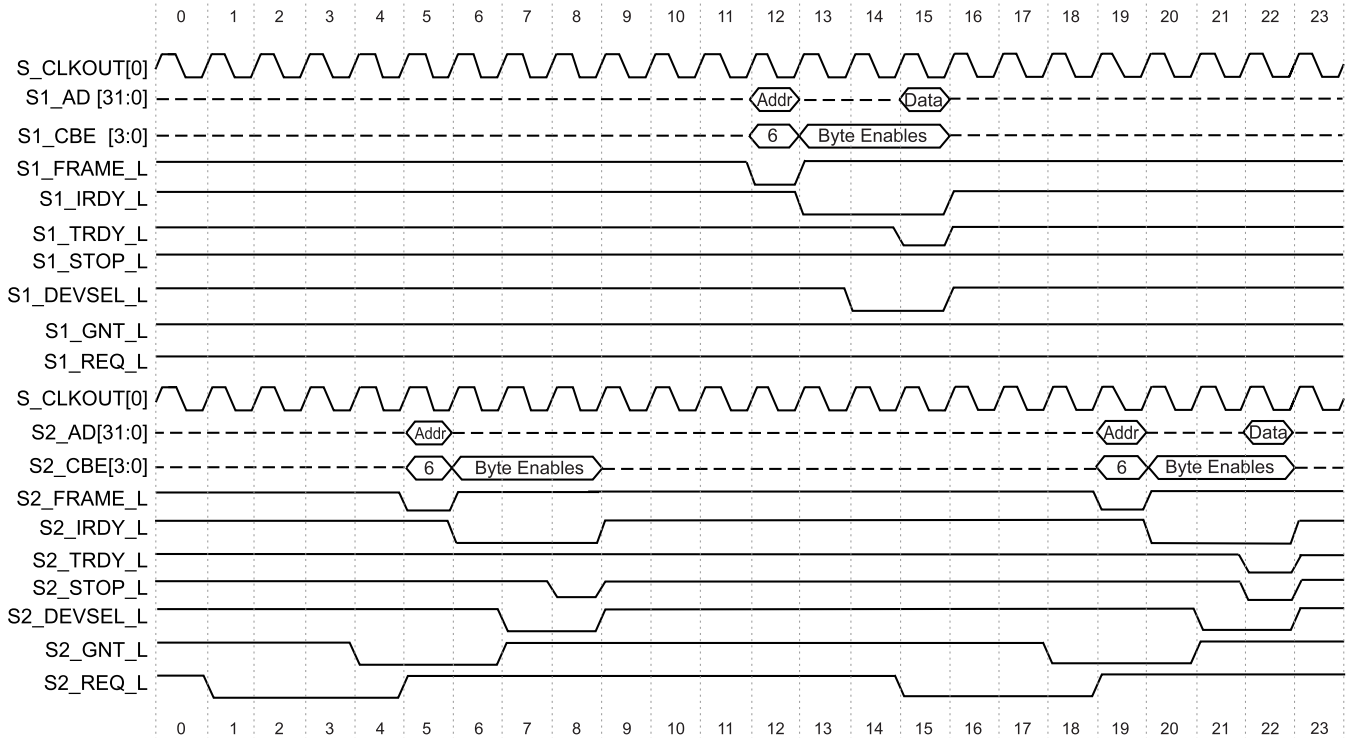

Figure 13. Downstream Delayed Memory Read Transaction (S1/33MHz-->S2/33MHz)

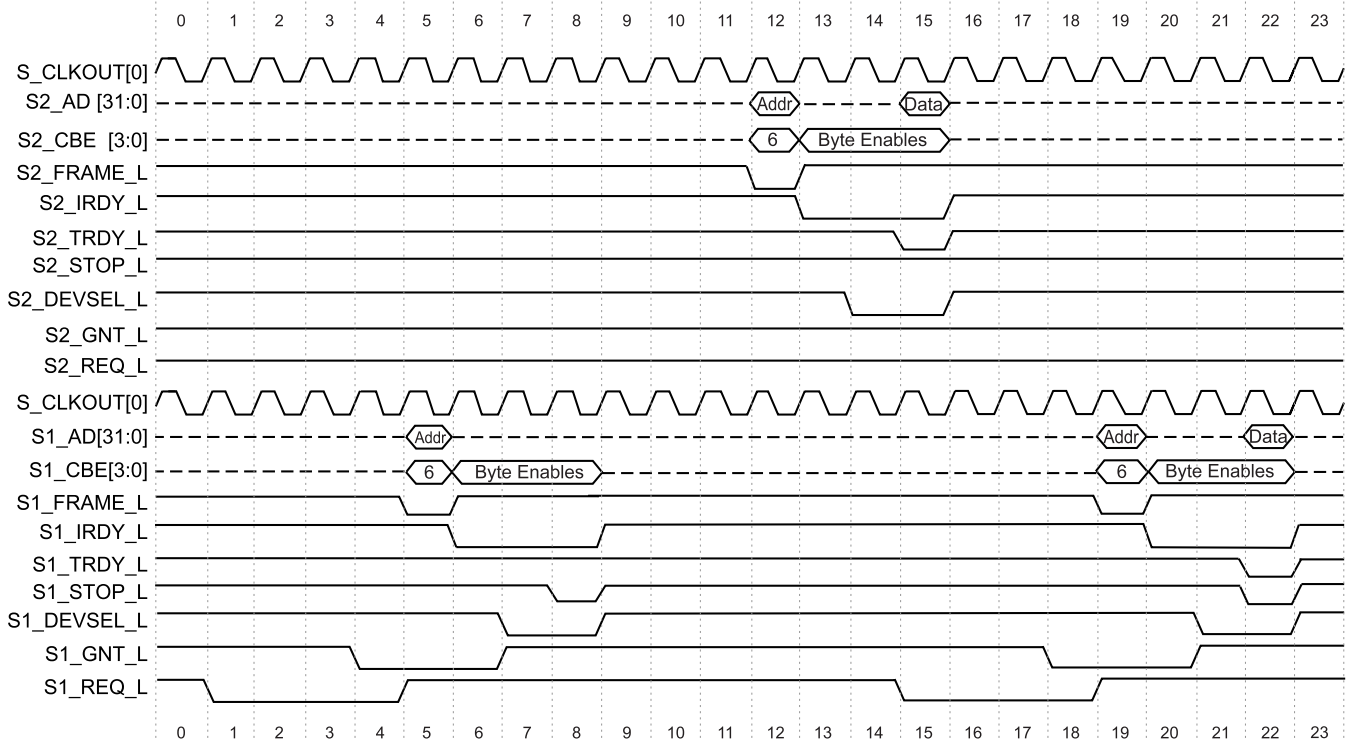

Figure 14. Upstream Delayed Memory Read Transaction (S/33MHz-->P/33MHz)

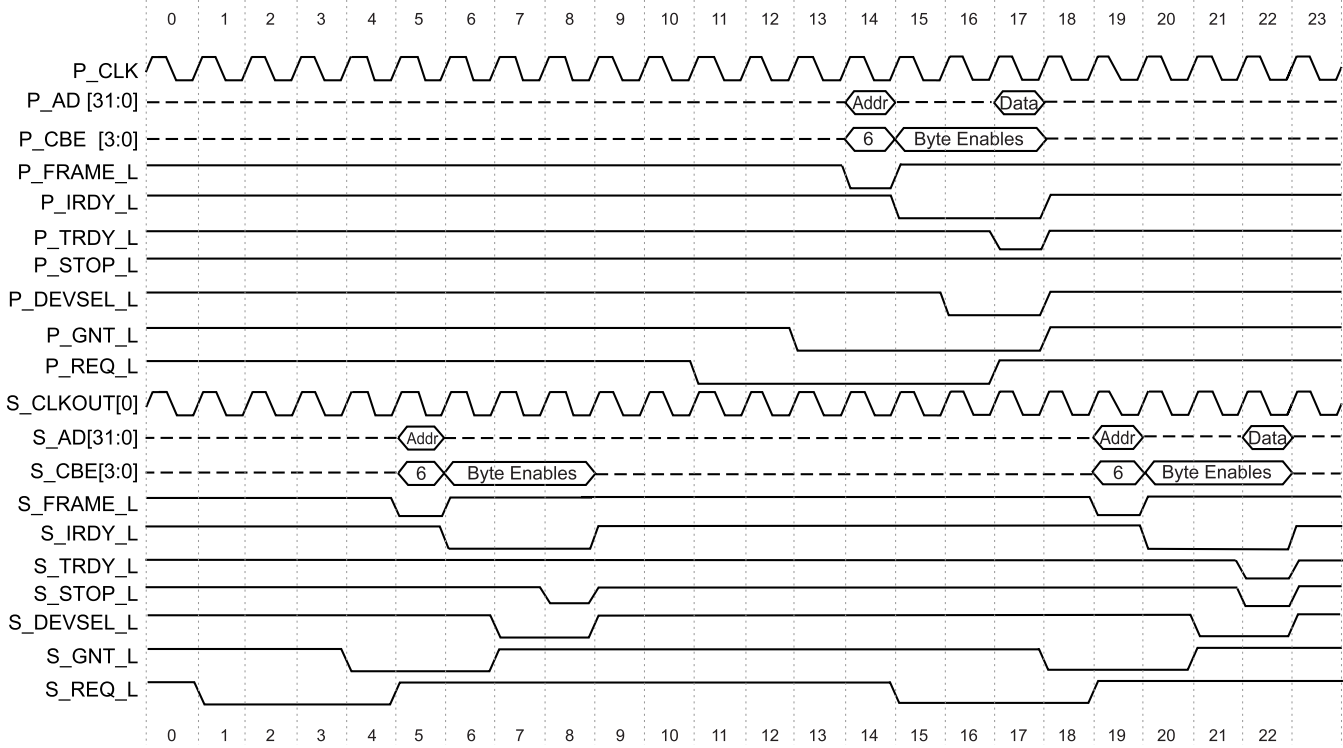
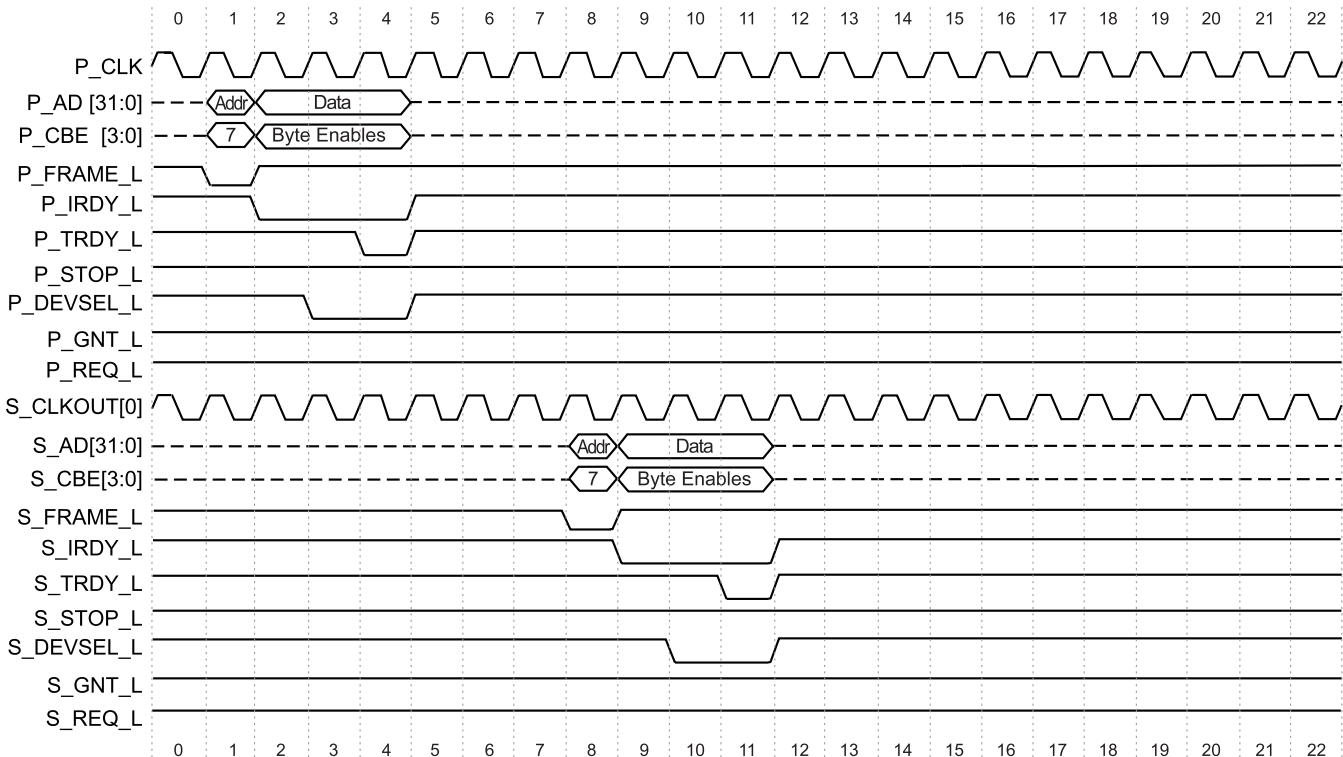

Figure 15. Downstream Posted Memory Write Transaction (P/33MHz-->S/33MHz)





ADVANCE INFORMATION

Figure 16. Downstream Posted Memory Write Transaction (S2/33MHz-->S1/33MHz)

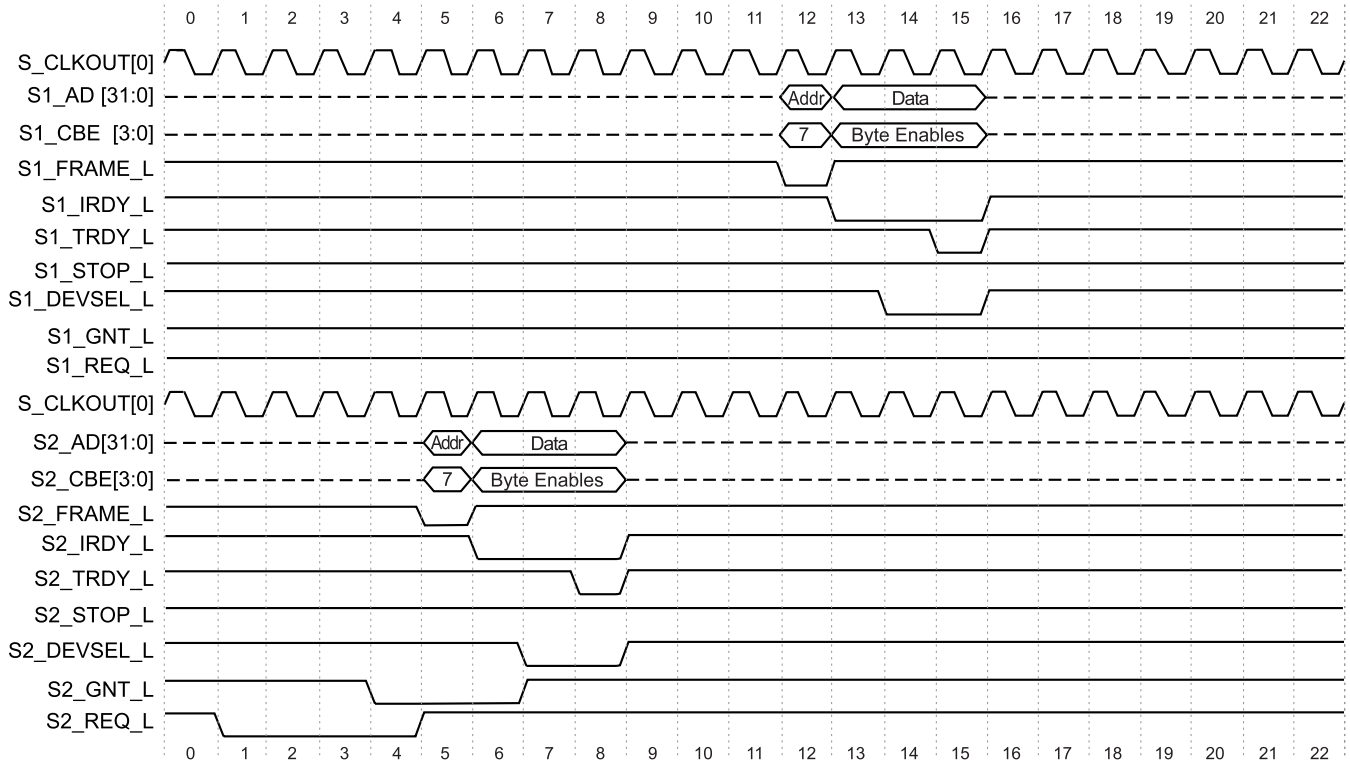

Figure 17. Downstream Posted Memory Write Transaction (S1/33MHz-->S2/33MHz)

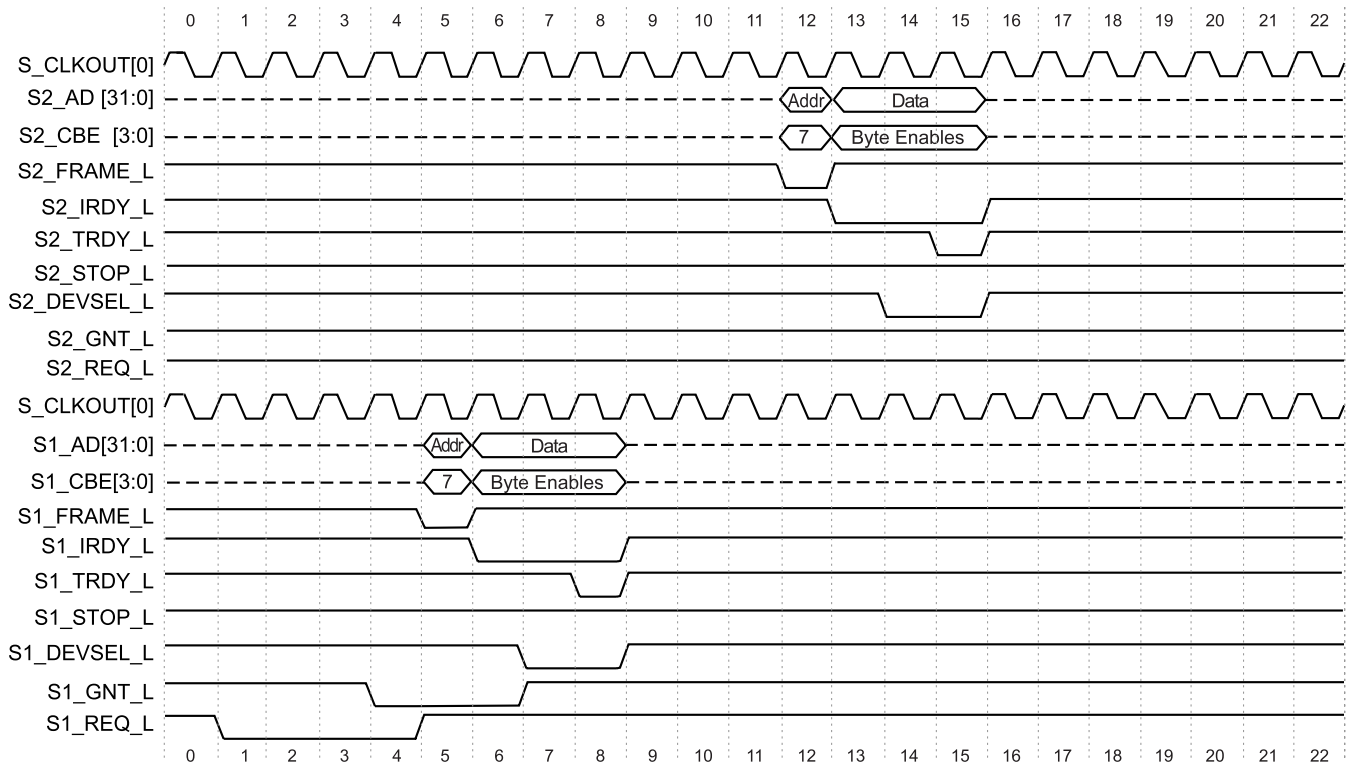

Figure 18. Upstream Posted Memory Write Transaction (S/33MHz-->P/33MHz)

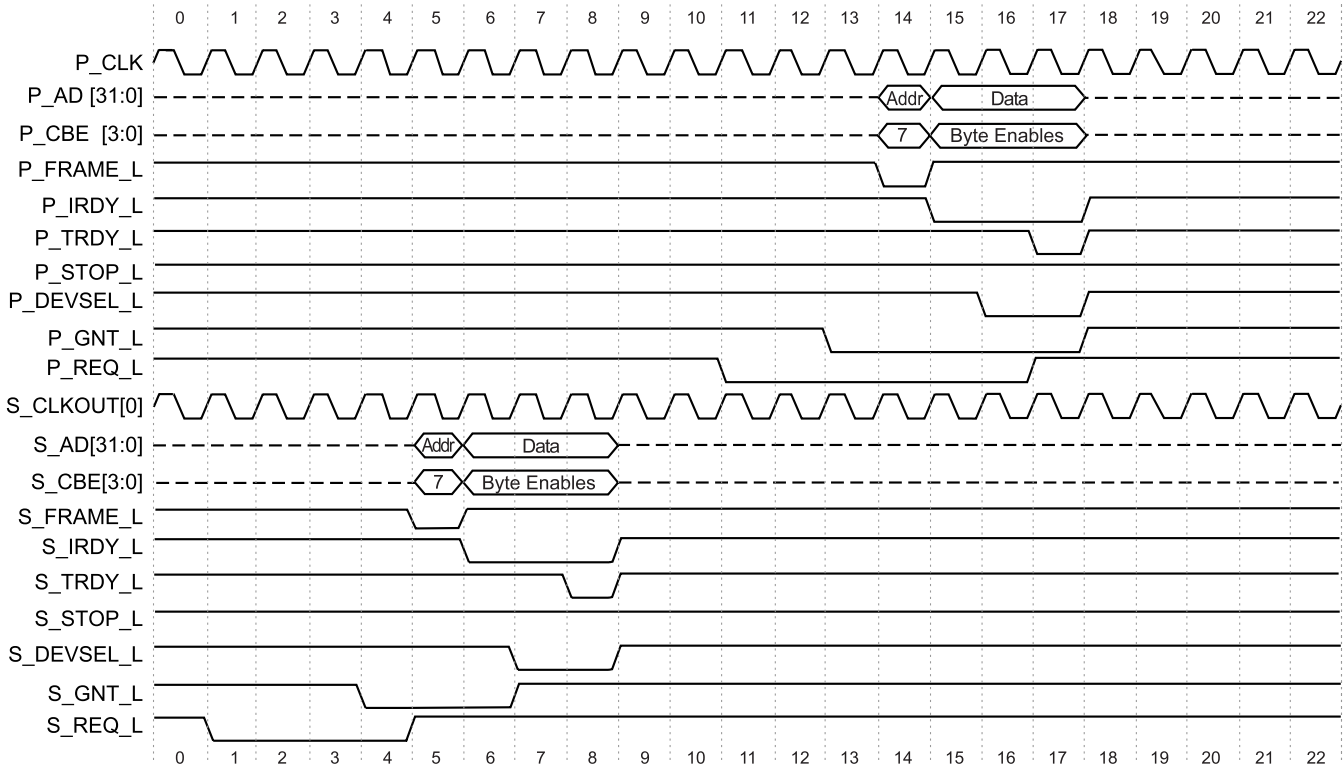
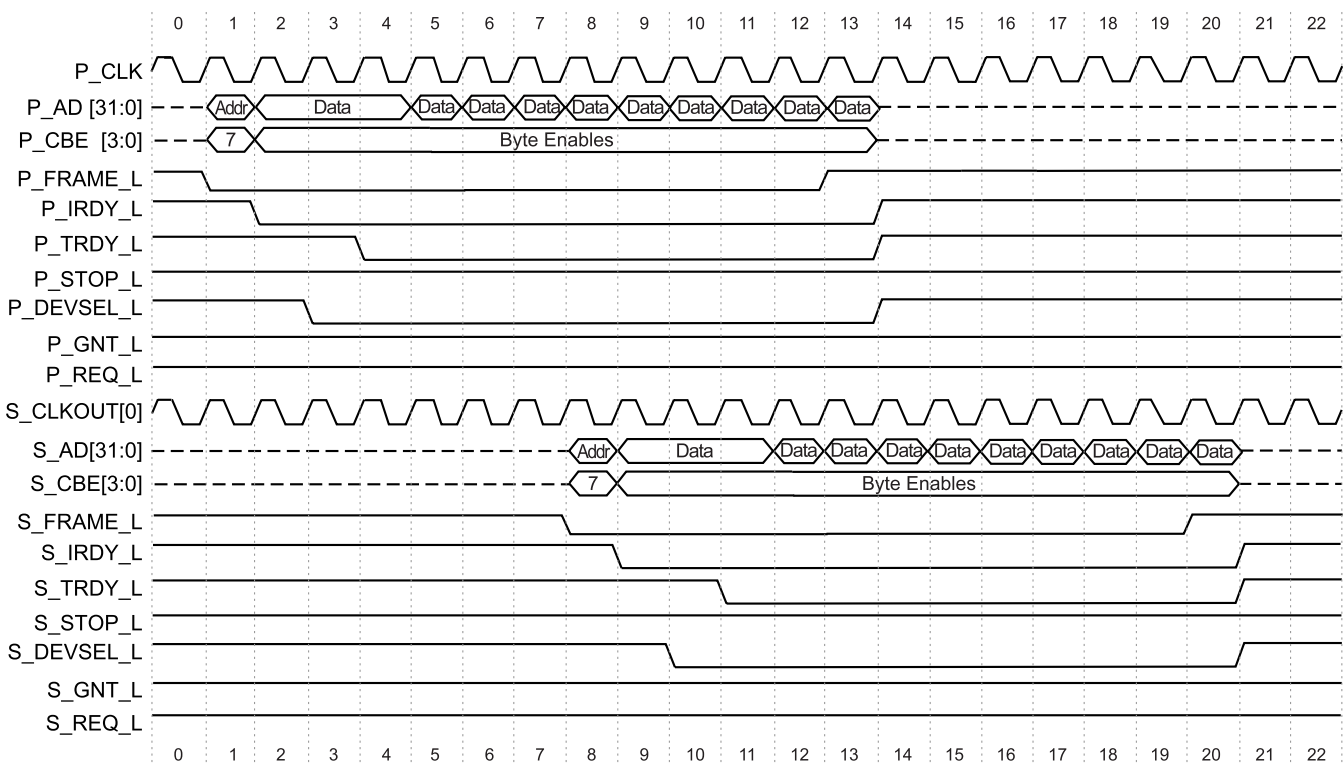

Figure 19. Downstream Flow-Through Posted Memory Write Transaction (P/33MHz-->S/33MHz)





ADVANCE INFORMATION

Appendix A PI7C7100 3-Port PCI Bridge

Figure 20. Downstream Flow-Through Posted Memory Write Transaction (S2/33MHz-->S1/33MHz)

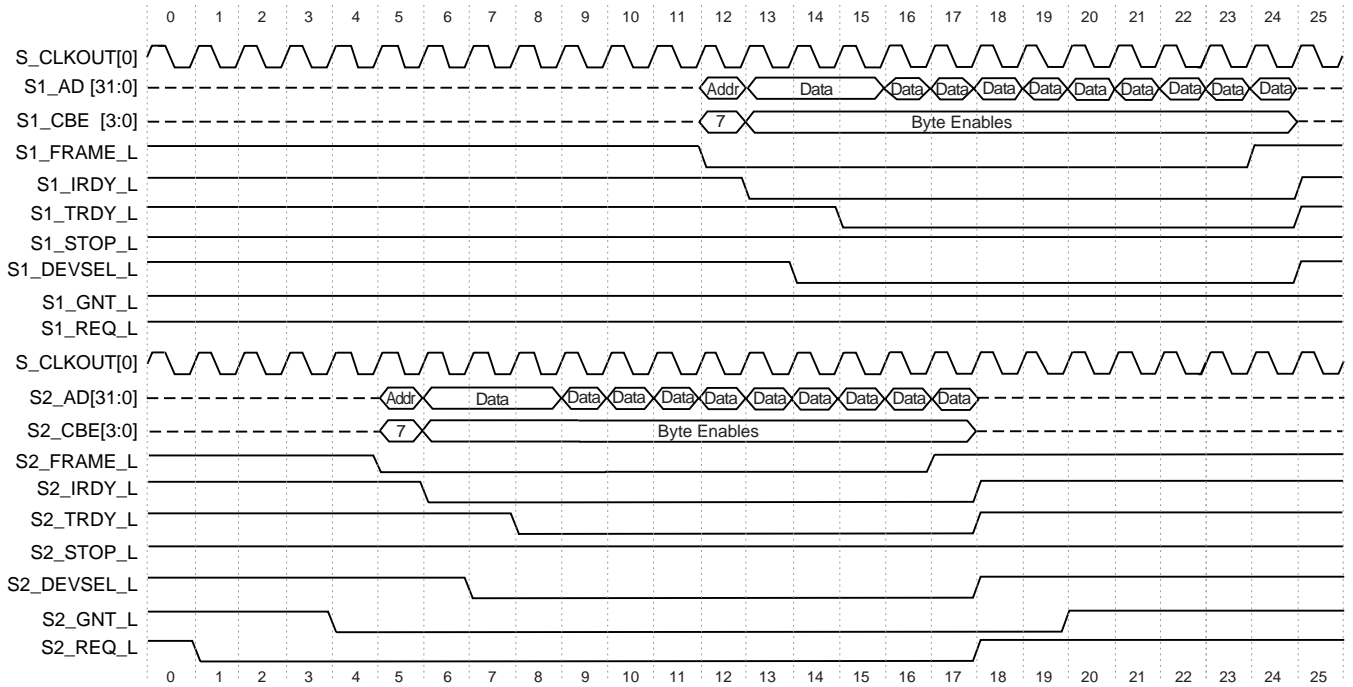
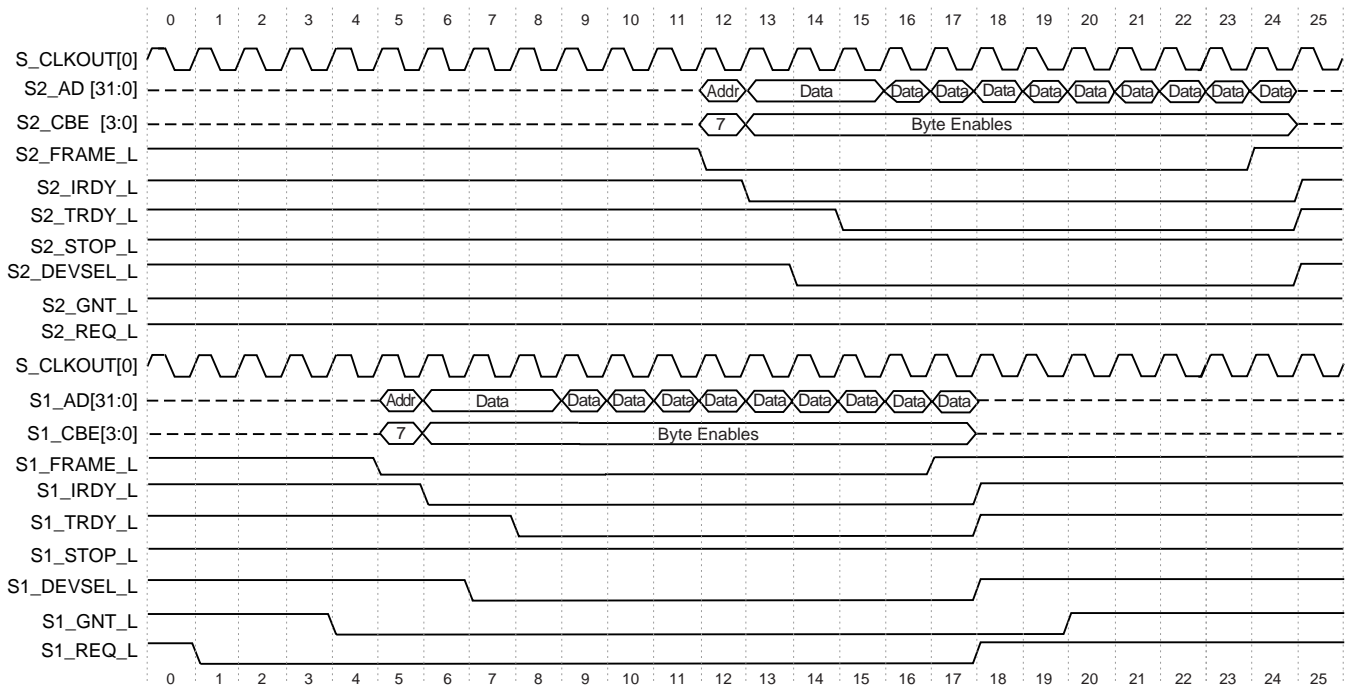

Figure 21. Downstream Flow-Through Posted Memory Write Transaction (S1/33MHz-->S2/33MHz)





ADVANCE INFORMATION

Appendix A PI7C7100 3-Port PCI Bridge

Figure 22. Upstream Flow-Through Posted Memory Write Transaction (S/33MHz-->P/33MHz)

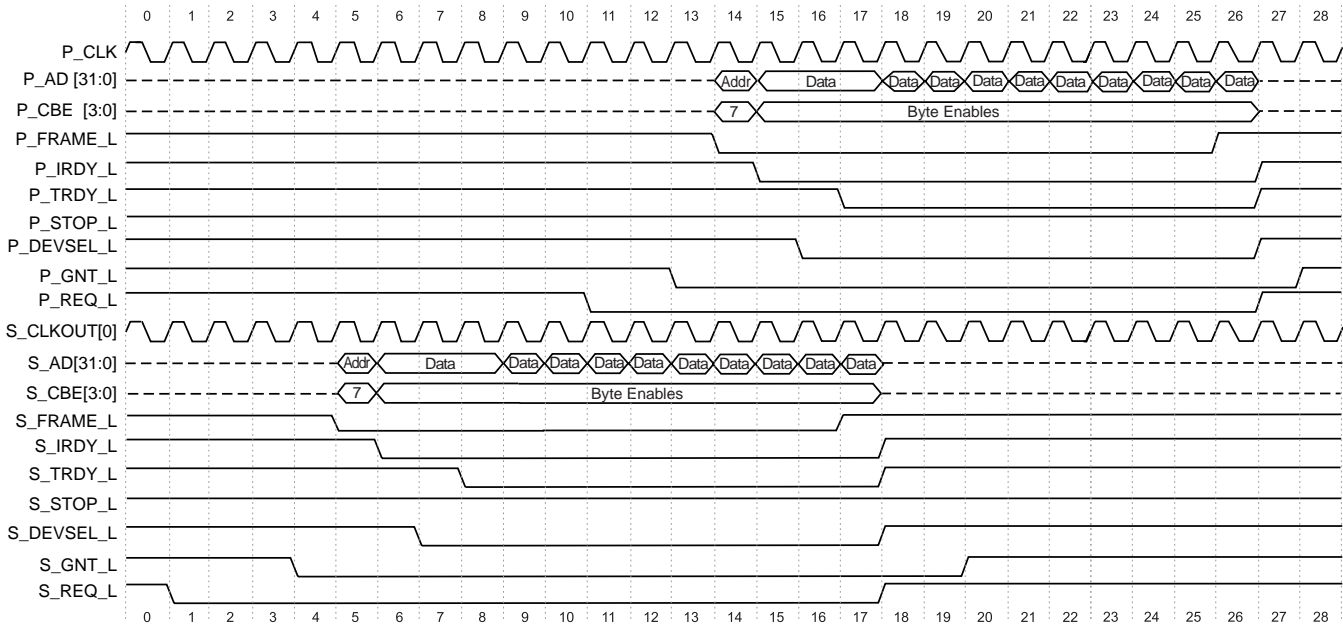

Figure 23. Downstream Delayed I/O Read Transaction (P --> S)

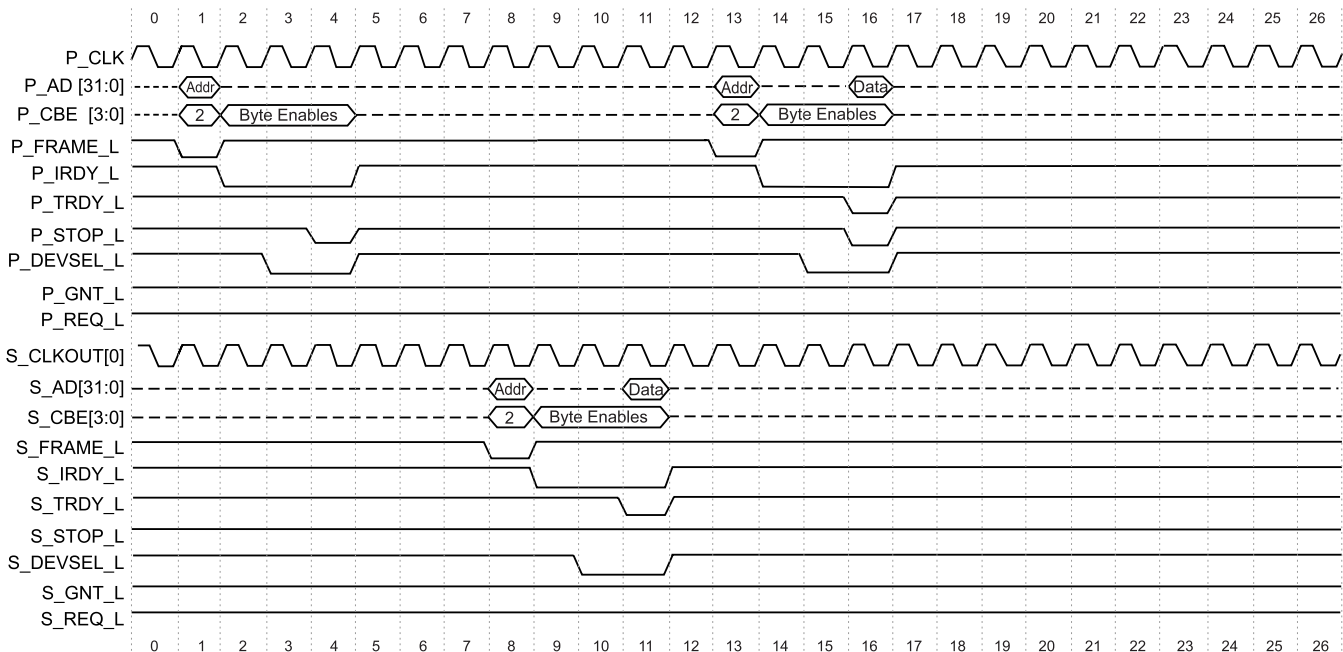

Figure 24. Downstream Delayed I/O Read Transaction (S2/33MHz-->S1/33MHz)

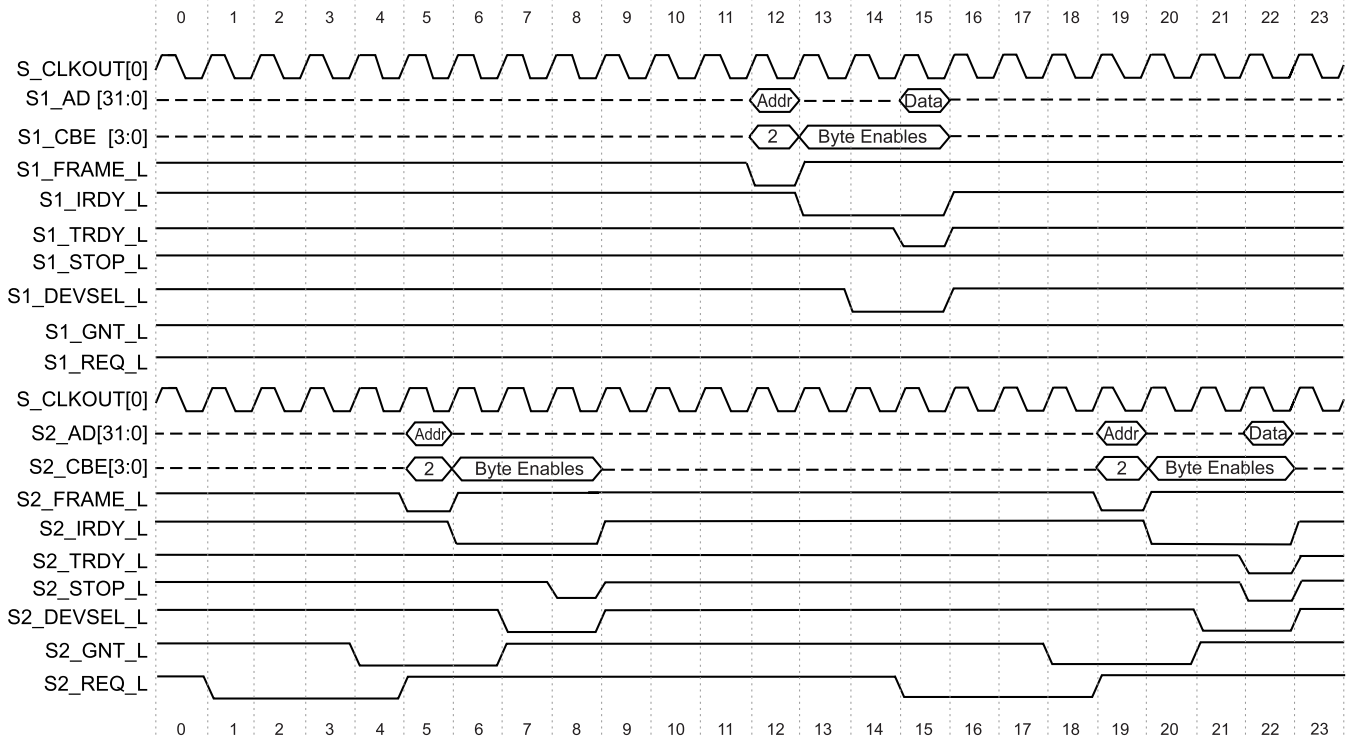

Figure 25. Downstream Delayed I/O Read Transaction (S1/33MHz-->S2/33MHz)

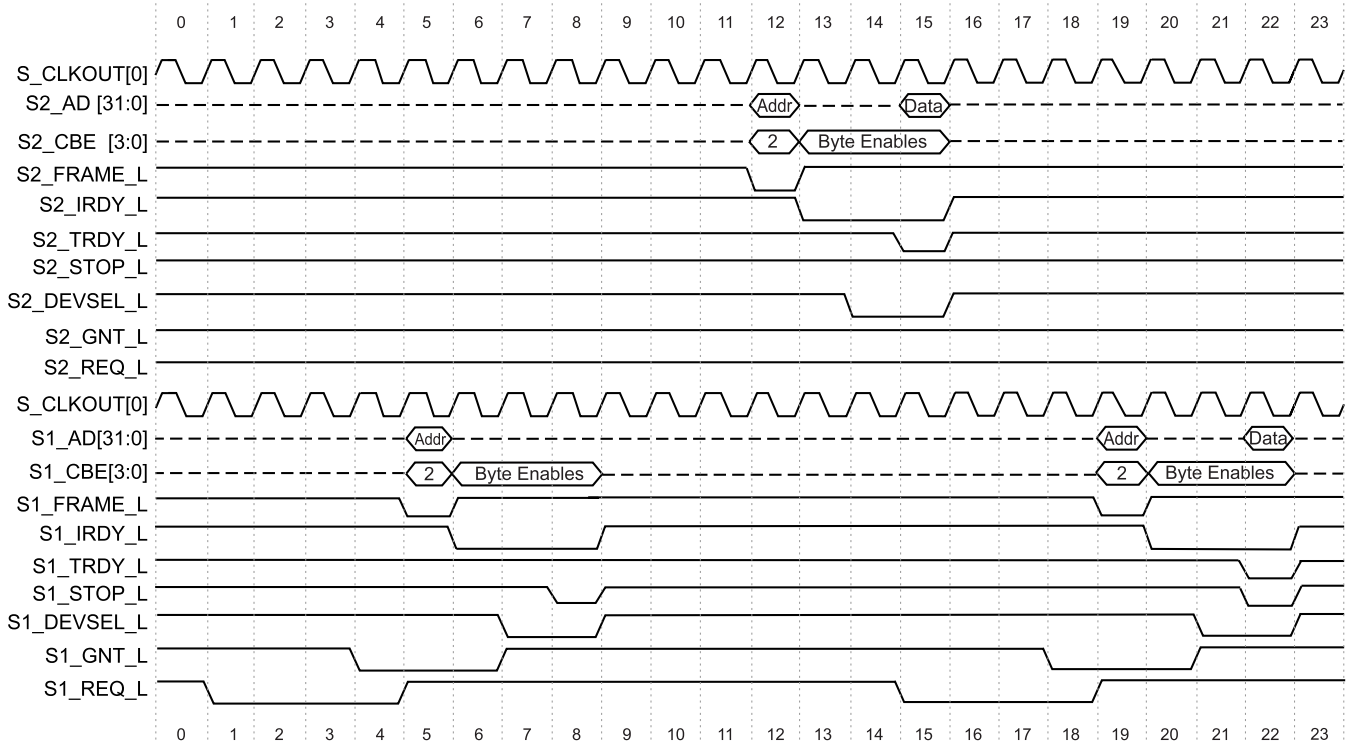

Figure 26. Upstream Delayed I/O Read Transaction (S/33MHz-->P/33MHz)

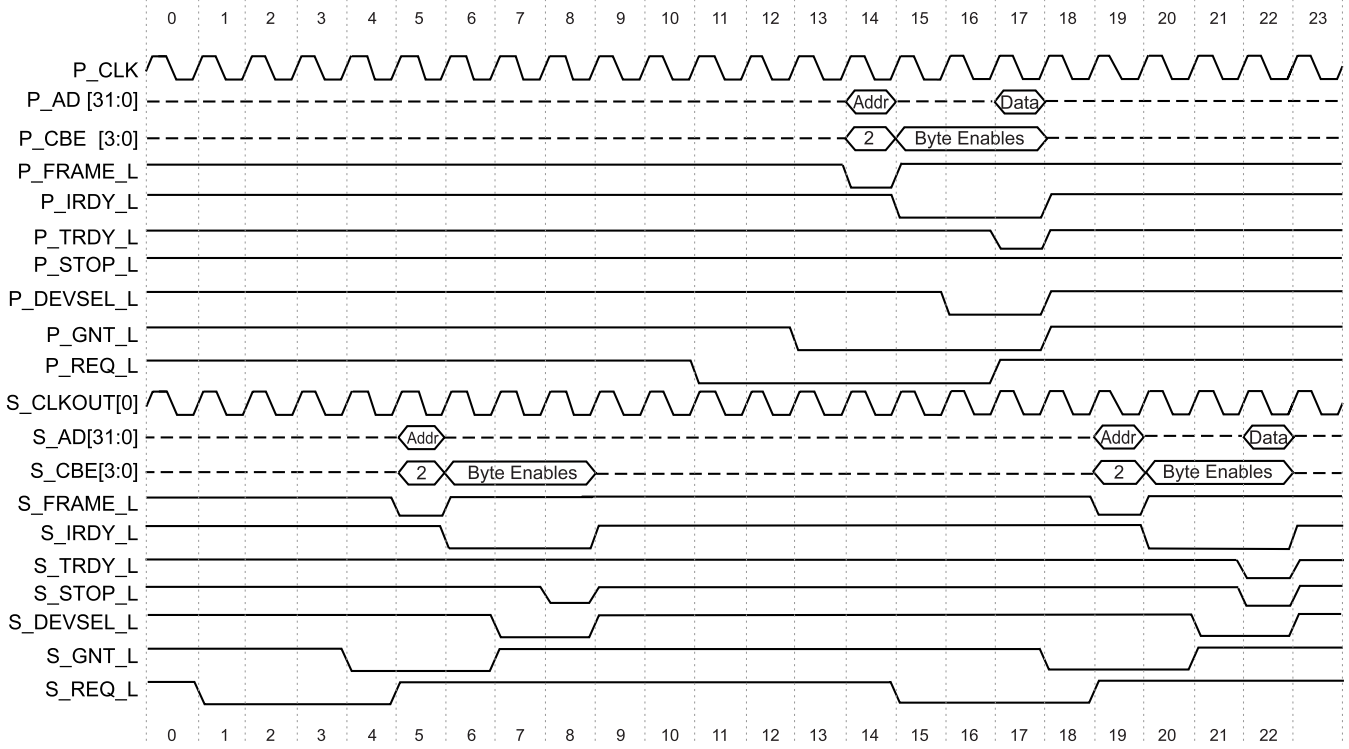

Figure 27. Downstream Delayed I/O Write Transaction (P --> S)

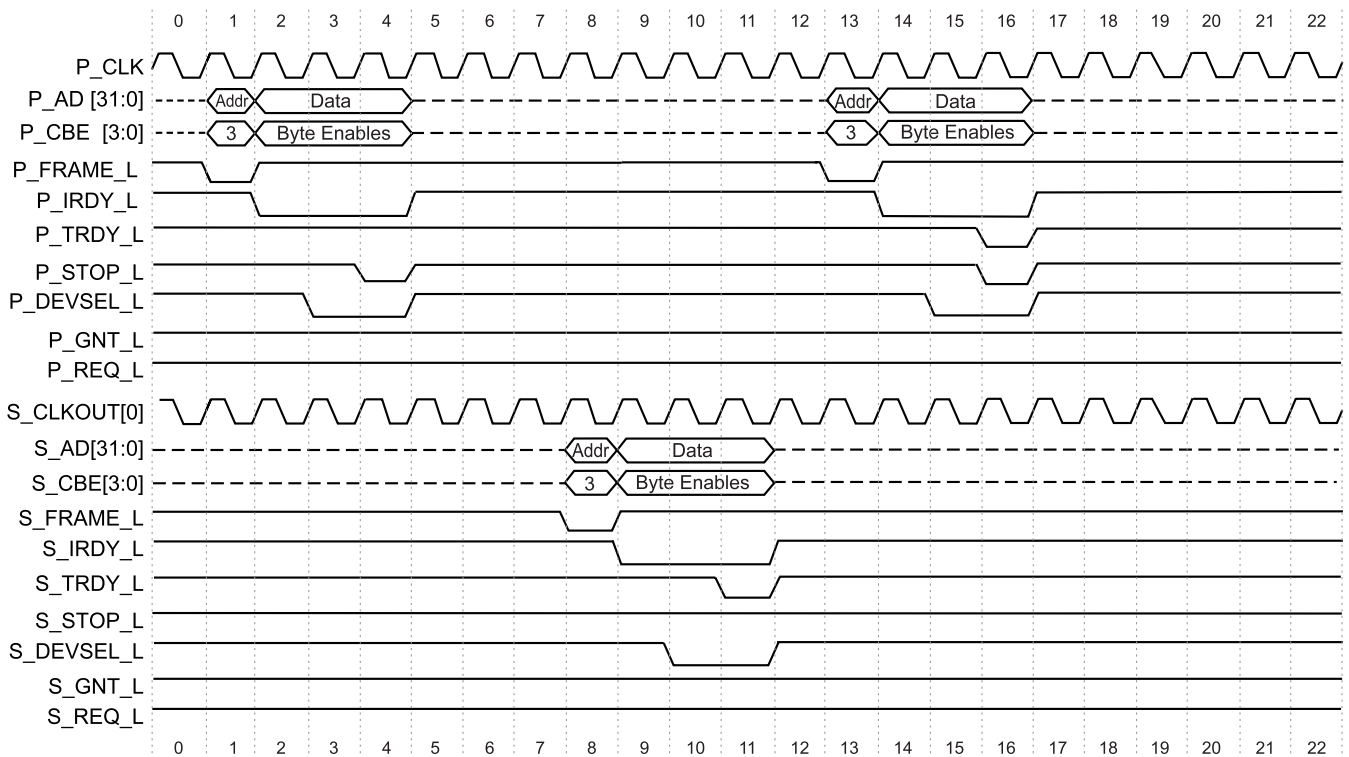

Figure 28. Downstream Delayed I/O Write Transaction (S2/33MHz-->S1/33MHz)

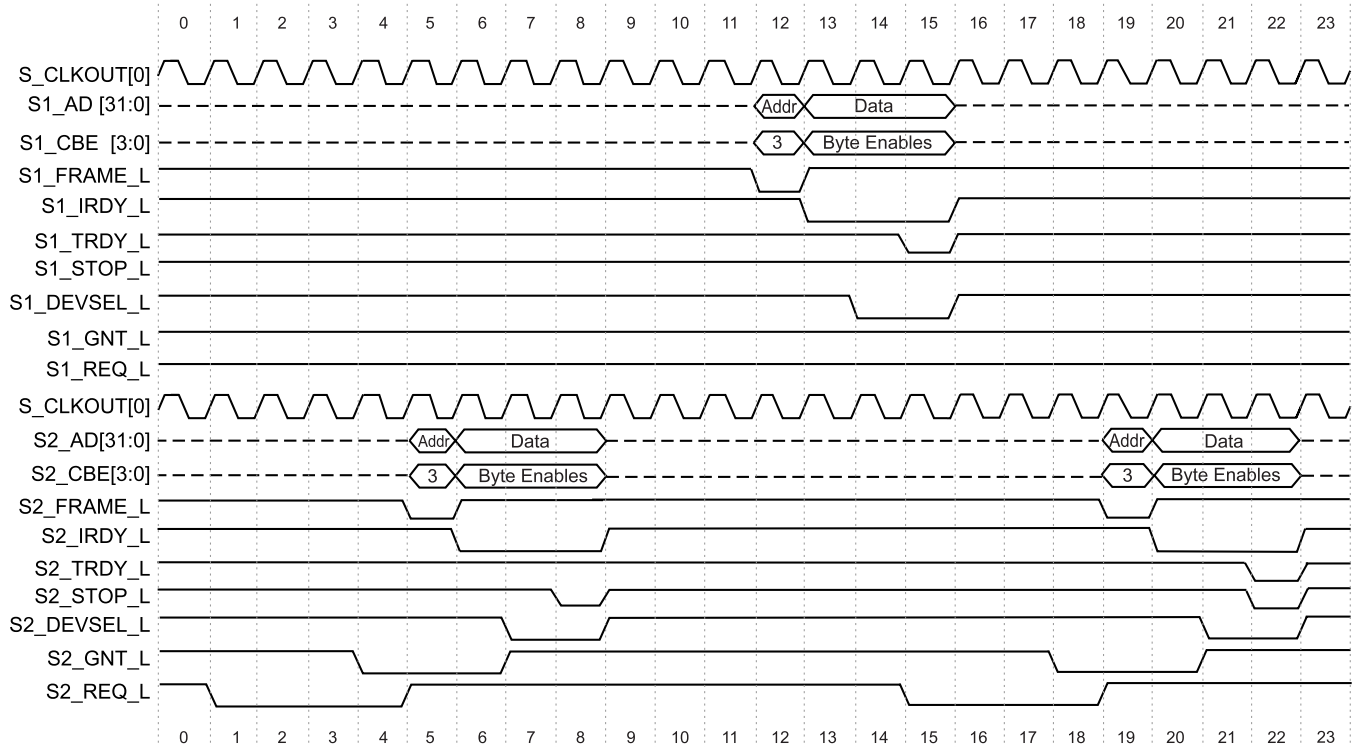
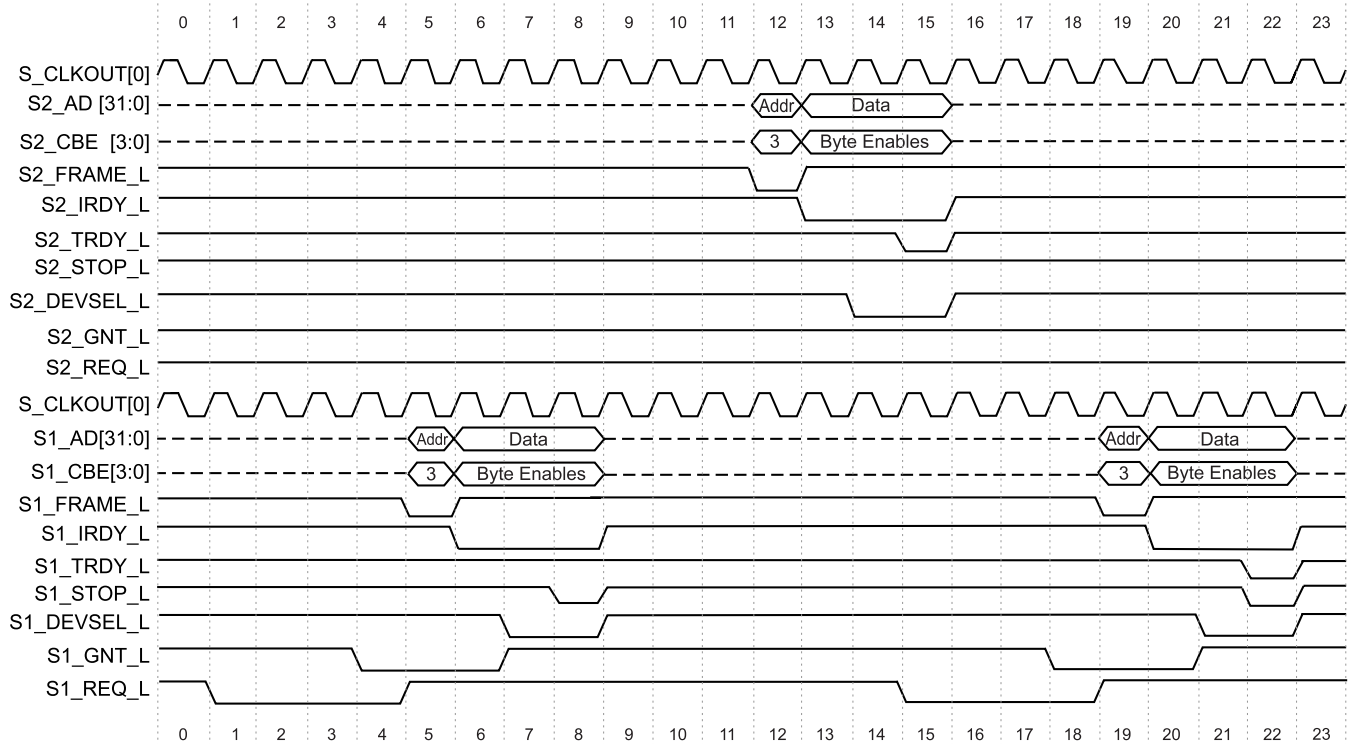

Figure 29. Downstream Delayed I/O Write Transaction (S1/33MHz-->S2/33MHz)





ADVANCE INFORMATION

Appendix A
PI7C7100
3-Port PCI Bridge

Figure 30. Upstream Delayed I/O Write Transaction (S --> P)

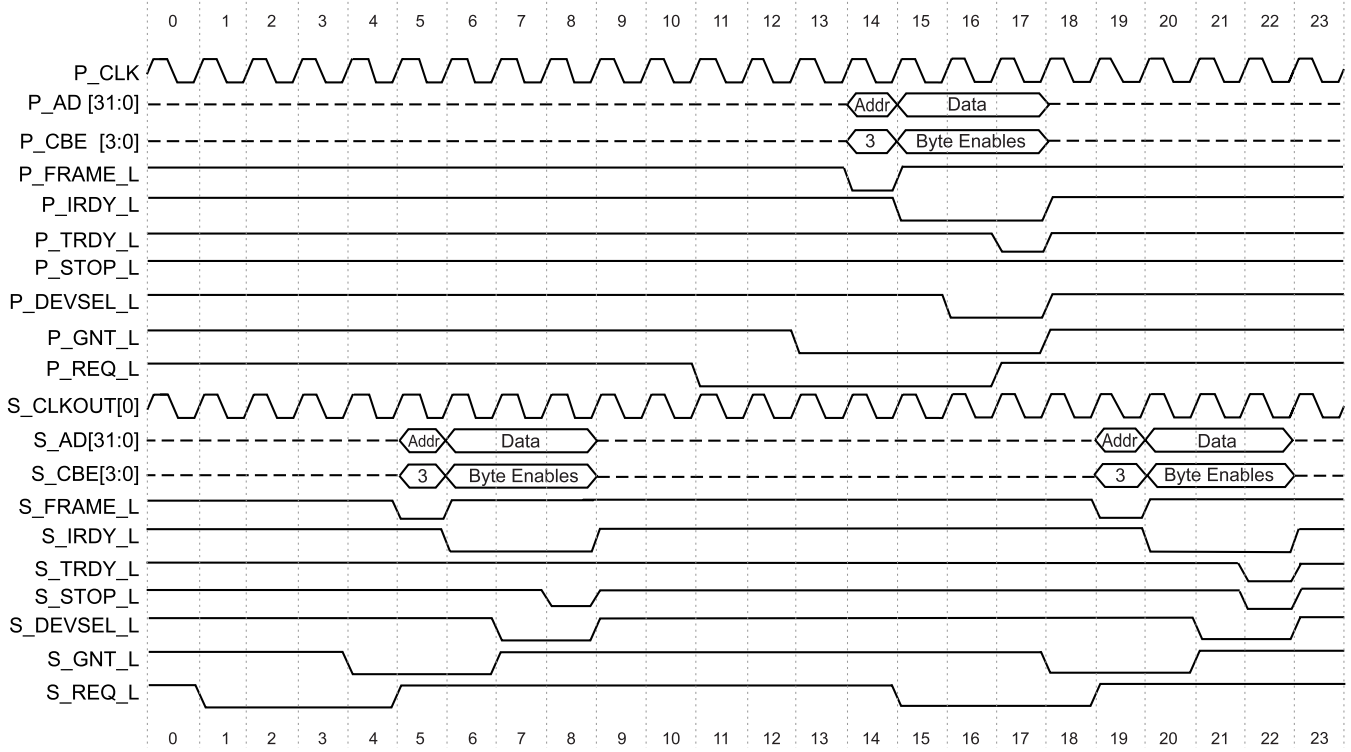



ADVANCE INFORMATION

Appendix A
PI7C7100
3-Port PCI Bridge



PI7C7100 3-Port PCI Bridge

Appendix B

**Evaluation
Board**

User's Manual



ADVANCE INFORMATION

Appendix B
PI7C7100
3-Port PCI Bridge



PI7C7100 Evaluation Board User's Manual

General Information

1. Please make sure you have included with your PI7C7100 evaluation board, the five-page schematic and the preliminary specification for the PI7C7100.
2. Check all jumpers for proper settings:

Pin Name	Jumper	Function	Position
S_CFN#	JP4	Internal arbiter enable	1-2 (0)
S1_EN	JP5	S1 bus enable	2-3 (1)
S2_EN	JP6	S2 bus enable	2-3 (1)
SCAN_EN	JP7	SCAN control	1-2 (0)
SCAN_EN	JP7	SCLK_IN as clock input	2-3 (1)
PLL_TM	JP8	PLL test mode disable	1-2 (0)
BYPASS	JP9	PLL disable	2-3 (1)
P_FLUSH#	JP10	Primary FIFO flush disable	2-3 (1)

3. Check and make sure there are no shorts between power (3.3V, 5V, 12V, and -12V) and ground.
4. Plug evaluation board in any PCI slot on your system. Make sure your system is powered off before doing so.
5. Connect any PCI devices on the secondary slots of the evaluation board. Be careful that the orientation of the card is correct (see Diagram A).

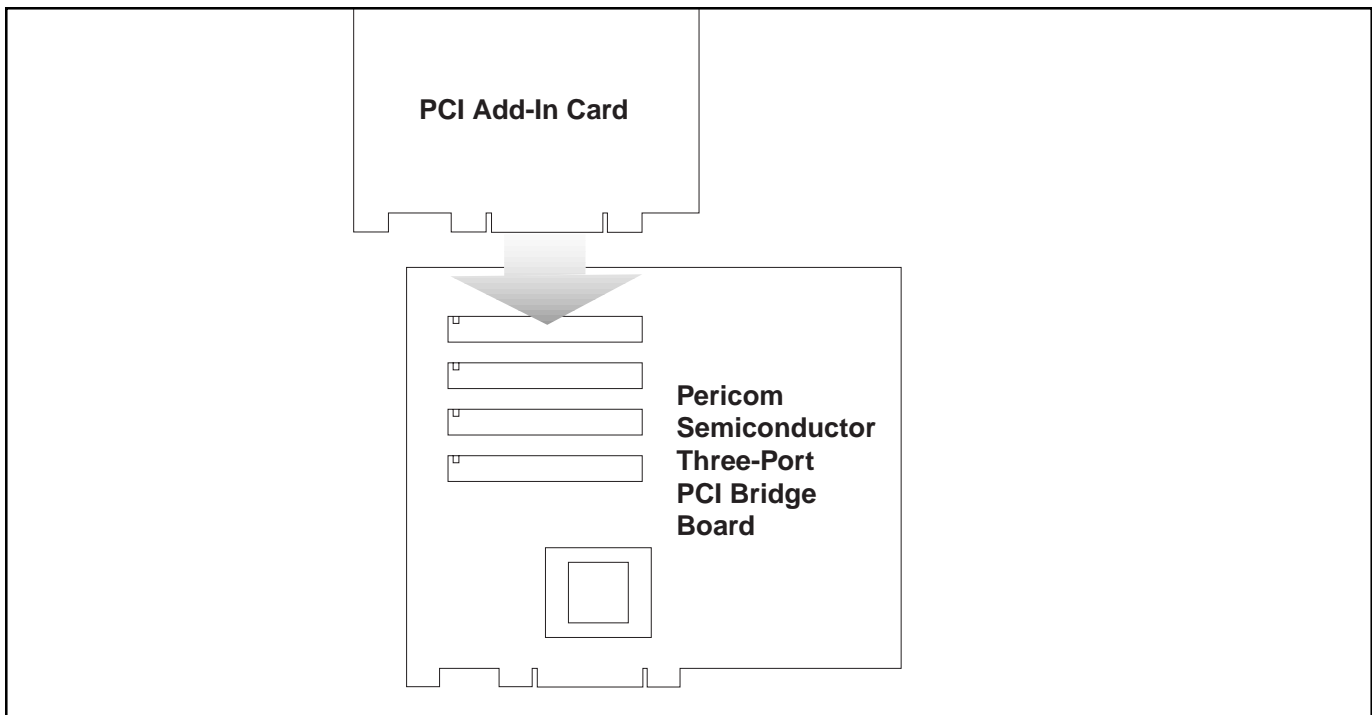

Diagram A



ADVANCE INFORMATION

Appendix B
PI7C7100
3-Port PCI Bridge

General Information *(continued)*

6. Turn on the power for the system. Your OS should already have drivers for the PI7C7100 evaluation board. In Win9X, Plug and Play should detect the device as a PCI-to-PCI bridge. The system may prompt you for the Win9X CD for the drivers. The OS will detect two PCI-to-PCI bridges as the PI7C7100 has two secondary PCI buses. In Win NT, you should not have to install drivers.
7. Install drivers for any PCI devices you have attached to the evaluation board.
8. If any of the steps are unclear or were unsuccessful, please contact your Pericom support person at 408-435-0800.
9. Thank you for evaluating Pericom Semiconductor Corporation's products.

Frequently Asked Questions

1. What is the function of SCAN_EN?

SCAN_EN is for a full scan test or S_CLKIN select. During SCAN mode, SCAN_EN will be driven to logic “0” or “logic “1” depending on functionality. During normal mode, if SCAN_EN is connected to logic “0” (JP7 in the 1-2 position), S_CLKIN will be used for PLL test only when PL_TM is active. If SCAN_EN is connected to logic “1” (JP7 in the 2-3 position), S_CLKIN will be the clock input for the secondary buses. All secondary clock outputs, S_CLKOUT [15:0], are still derived from P_CLK with 0-10ns delay. The S_CLKOUT [15:0] should be disabled by programming the bits [15:0] in both configuration registers 1 and 2 at offset 68h.

2. What is the function of SCAN_TM#?

SCAN_TM# is for full scan test and power on reset for the PLL. SCAN_TM# should be connected to logic “1” or to an RC path (R1 and C13) during normal operation.

3. How do you use the external arbiter?

- Disable the on chip arbiter by connecting S_CFN to logic “1” (JP4 in the 2-3 position).
- Use S1_REQ0# as GRANT and S1_GNT0# as REQUEST on the S1 bus.
- Use S2_REQ0# as GRANT and S2_GNT0# as REQUEST on the S2 bus.

4. What is the purpose of having JP1, JP2, and JP3?

JP1, JP2, and JP3 are designed for easy access to the primary bus signals. You may connect any of these pins to an oscilloscope or a logic analyzer for observation. No connection is required for normal operation. The following table indicates which bus signals correspond to which pins.

	1	2	3	4	5	6	7	8	9	10	11	12	13	14	15	16
JP2	REQ	AD29	AD26	CBE3	AD21	AD18	CBE2	IRDY	LOCK	PAR	AD14	AD11	CBE0	AD6	AD5	AD0
JP3	AD31	AD28	AD25	AD23	AD20	AD17	FRAME	DVSEL	PERR	CBE1	AD13	AD10	AD8	AD4	AD2	GND
JP1	GNT	AD30	AD27	AD24	AD22	AD19	AD16	IRDY	STOP	SERR	AD15	AD12	AD9	AD7	AD3	AD1

5. What is the purpose for having U17, U19, and U20?

U17, U19, and U20 are designed for easy access to the digital ground planes for observation.

6. How is the evaluation board constructed?

The evaluation board is a six-layer PCB. The top and bottom layers (1 and 6) are for signals, power, and ground routing. Layer 2 and layer 5 are ground planes. Layer 3 is a digital 3.3V power plane. Layer 4 is a digital 5V power plane with an island of analog 3.3V power.

7. What is the function of S_CLKIN?

The S_CLKIN pin is a test pin for the on chip PLL when PLL_TM is set to logic “1”. During normal operation, if PLL_TM is set to logic “0”, SCAN_TM# is set to logic “1”, and SCAN_EN is set to logic “1”, then S_CLKIN will be the clock input for both the secondary buses. However, the S_CLKOUT [15:0] are still derived by programming bits [15:0] in both configuration registers 1 and 2 at offset 68h.

8. What clock frequency combinations does the PI7C7100 support?

Primary Bus	Secondary (1 and 2) Buses
33MHz	33MHz

9. How are the JTAG signals being connected?

The JTAG signals consist of TRST#, TCK, TMS, TDI, and TDO. All the mentioned signals have weak internal pull-up connections. Therefore, no connection is needed if you want the JTAG circuit to be disabled. If you want to activate the JTAG circuit, you need to connect all five signals according to the JTAG specification (IEEE 1149).



ADVANCE INFORMATION

Appendix B
PI7C7100
3-Port PCI Bridge



PI7C7100 3-Port PCI Bridge

Appendix C

Schematics



ADVANCE INFORMATION

Appendix C
PI7C7100
3-Port PCI Bridge





ADVANCE INFORMATION

Appendix C PI7C7100 3-Port PCI Bridge

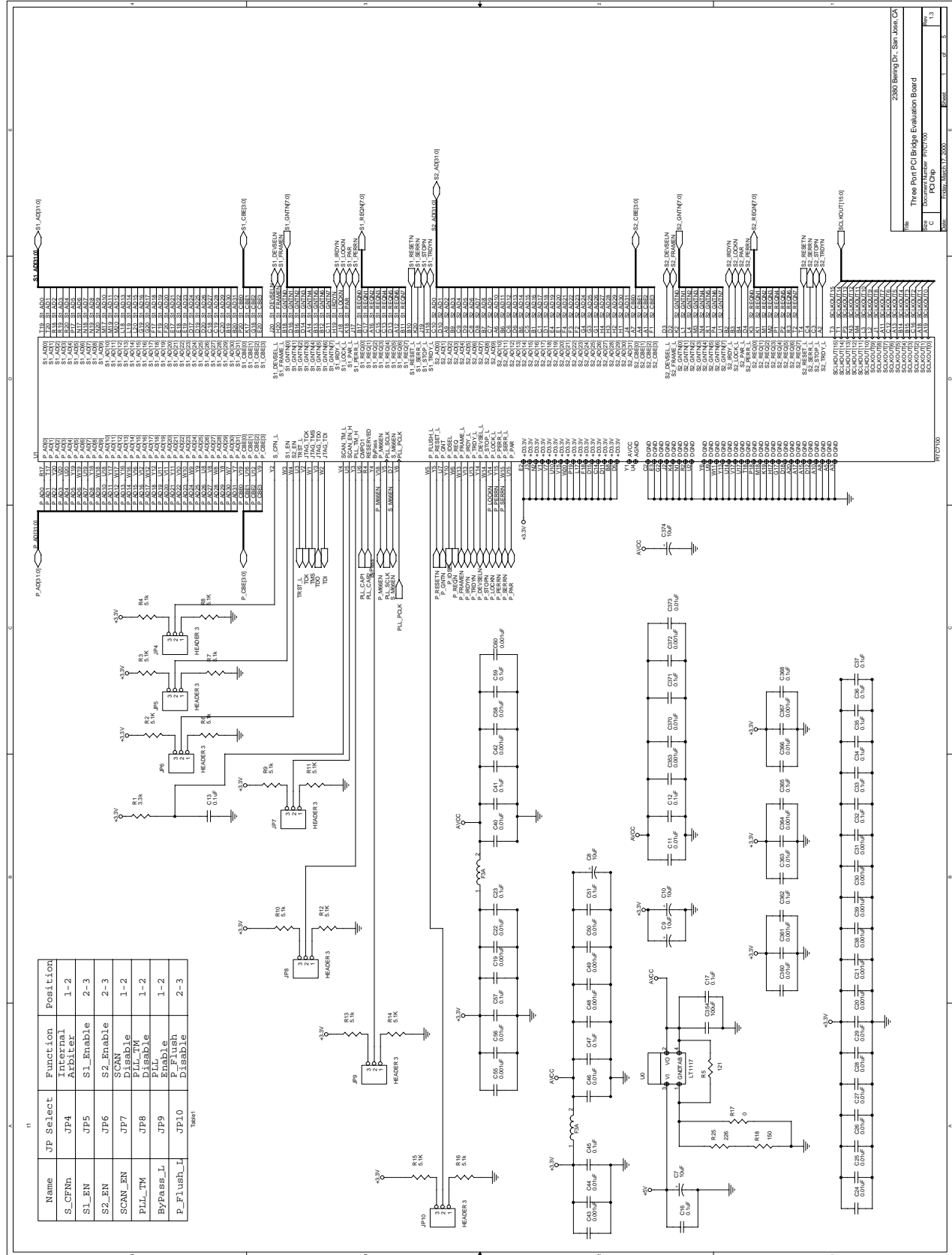

2500 Bering Dr., San Jose, CA
 Three Port PCI Bridge Evaluation Board
 PI7C7100
 Rev. 1.5

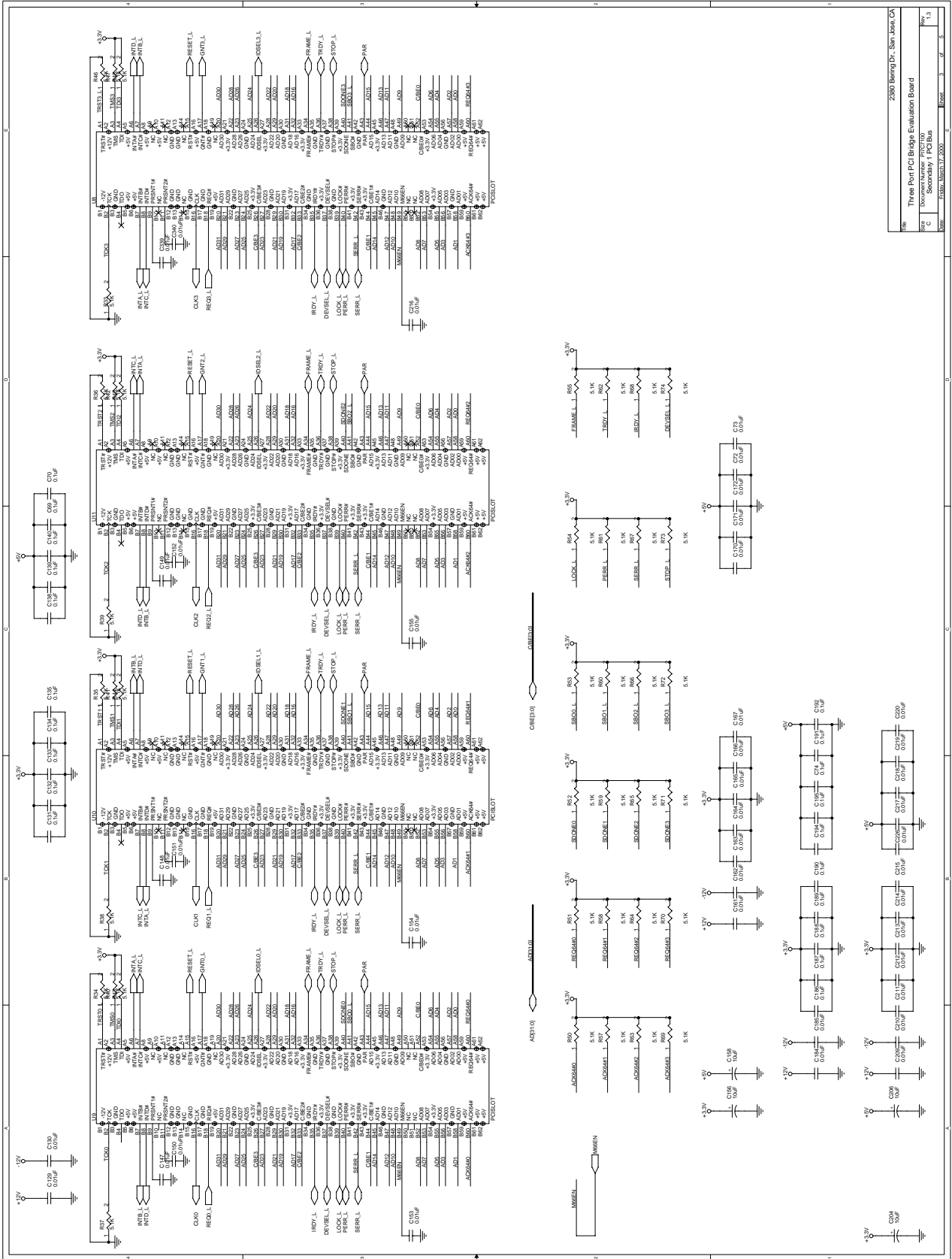

File	2500 Bering Dr., San Jose, CA
Title	Three Port PCI Bridge Evaluation Board
Size	80,000 Bytes
Doc Number	PI7C7100
Rev	Secondary 1 PCI Bus
Sheet	1 of 5

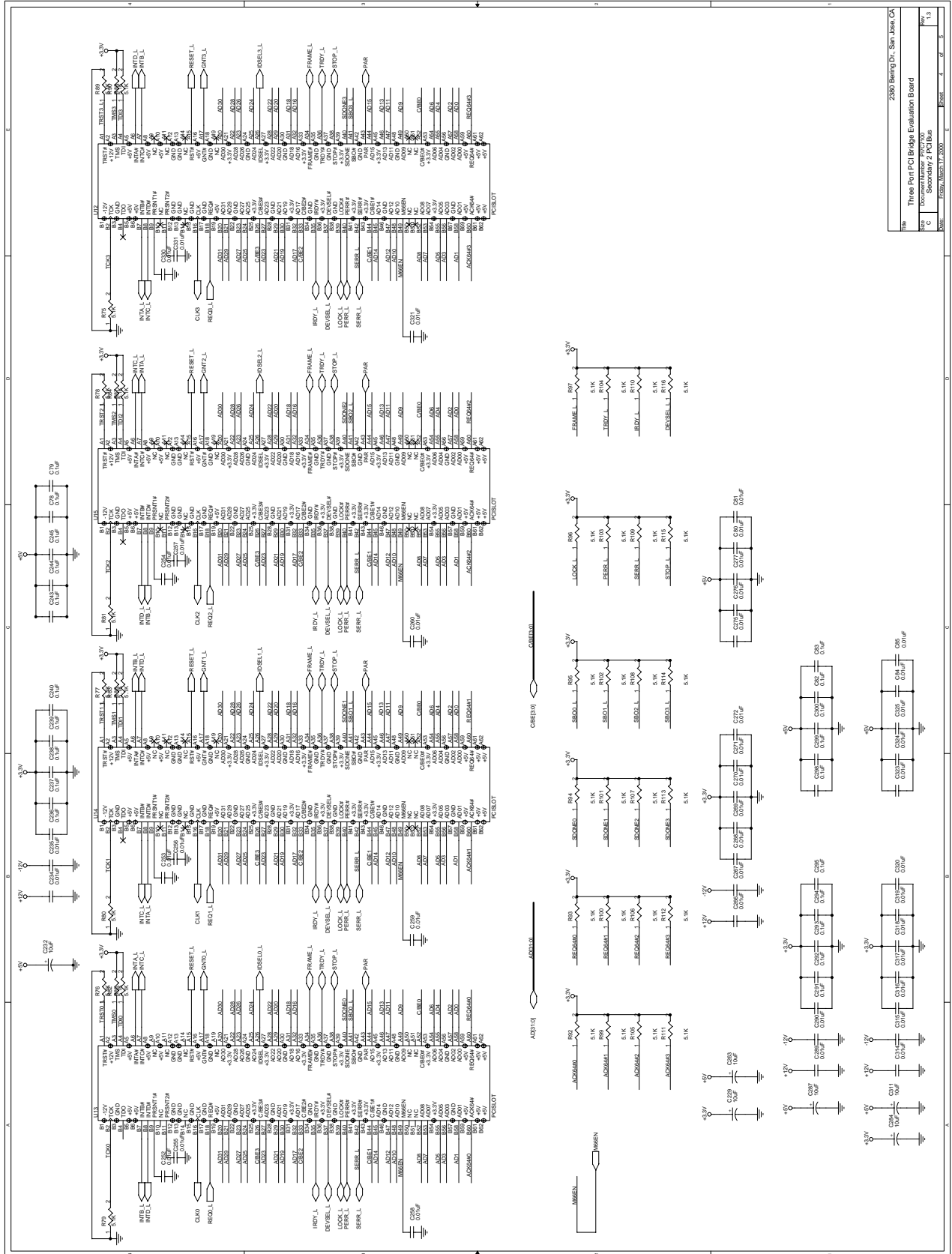

File	2800 Bering Dr., San Jose, CA			
Doc	Three Port PCI Bridge Evaluation Board			
Rev	Secondary 2 PCI Bus			
Page	1	2	3	4

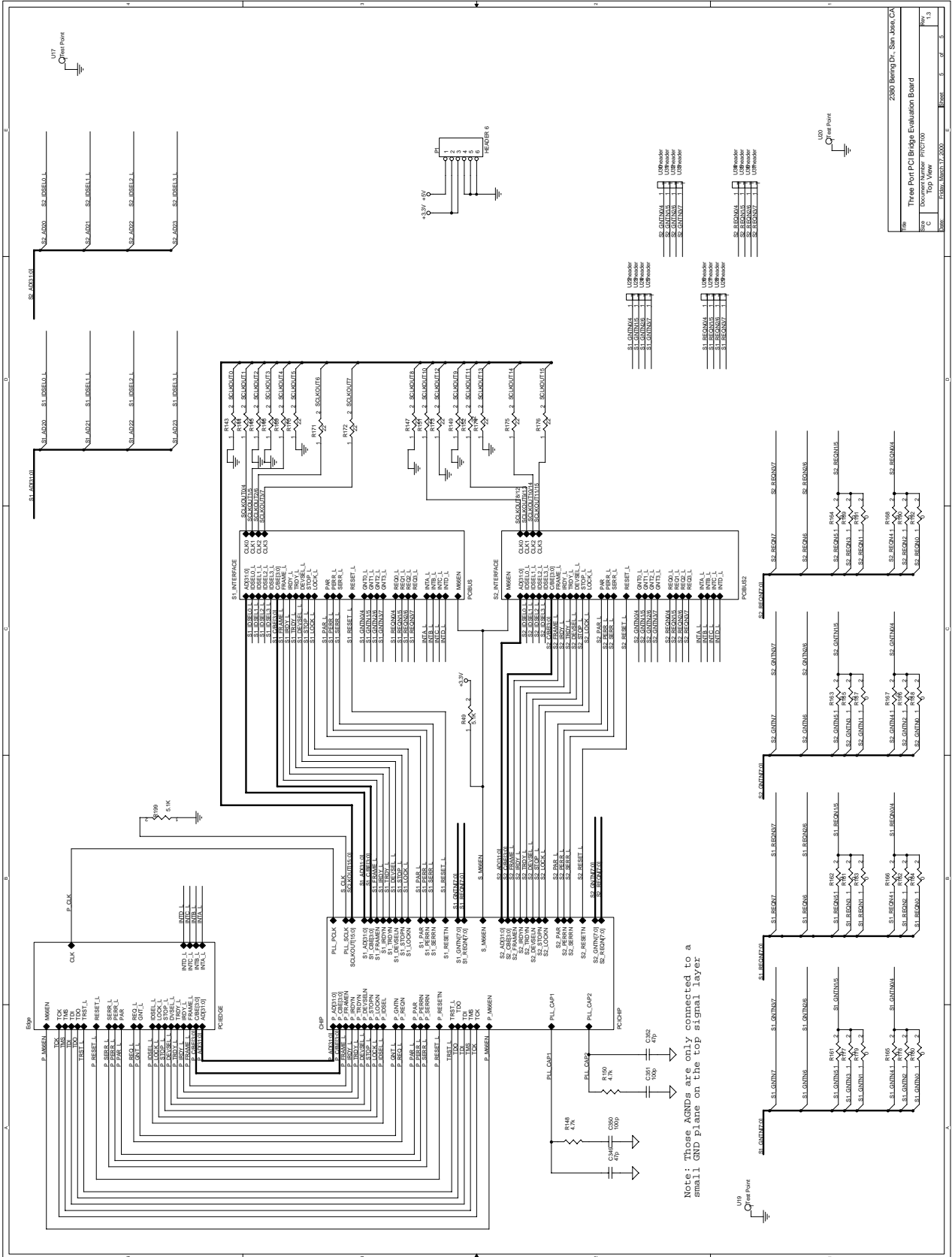

Note: These AGNDs are only connected to a small GND plane on the top signal layer



ADVANCE INFORMATION

Appendix C
PI7C7100
3-Port PCI Bridge



PI7C7100 3-Port PCI Bridge

Appendix D

Representatives & Distributors

**Pericom Corporate Offices****Corporate Headquarters**

Pericom Semiconductor Corp.
2380 Bering Drive,
San Jose, CA 95131-USA
1-800 435-2336
408 435-0800
408 435 1100 Fax
nolimits@pericom.com

Northern California, Western USA & British Columbia

Pericom Semiconductor Corp.
2380 Bering Drive,
San Jose, CA 95131-USA
1-800 435-2336
408 435-0800
408 435 1100 Fax
rgorshe@pericom.com

Southern California-USA

Pericom Semiconductor Corp.
3455 Lebon Street, Suite 1536
San Diego, CA 92212-USA
858 558-6975
858 558 6685 Fax
ns00@pericom.com

North Central & South Central USA

Pericom Semiconductor Corp.
5068 West Plano Parkway, Suite 300
Plano, TX 75093-USA
972 381-4209
972 381 4208
mmorse@pericom.com

Mid Atlantic and South East USA

Pericom Semiconductor Corp.
1143-B Executive Circle
Cary, NC 27511-USA
919 460-3177
919 460 3179 Fax
mward@pericom.com

North East and Mid and Eastern Canada

Pericom Semiconductor Corp.
Radnor Station Building #2
290 King of Prussia Road, Suite 104
Radnor, PA 19087
610.293.7400
610.293.7410 Fax
gfrancisco@pericom.com

Europe

Pericom Semiconductor Corp.
The Enterprise Center
1-2 Davy Road
Gorse Lane Industrial Center
Clacton On Sea, Essex, UK CO15 4XD
44 1255 479994
44 1255 223676 Fax
johara@pericom.com

China - Peoples Republic of China

Pericom Technology Inc.
481 Gui Ping Road 3F, Building 20
Shanghai, 200233
86 21 6485 0576
86 21 6485 2181 Fax
afock@pericom.com

Hong Kong

Pericom Technology Inc.
8 Wang Hoi Road, Unit 1517
Chevalier Commercial Center
Kowloon Bay, Hong Kong
852 2243 3660
852 2243 3667 Fax
qshuai@pti.com.cn

Taiwan R.O.C.

Pericom Semiconductor Corp.
11F, No. 18, Alley 1, Lane 768, Sec 4 Pa Te Road
Taipei, Taiwan - R.O.C.
886 2 2651 5159
886 2 2653 0041 Fax
mchiang@pericom.com

Singapore

Pericom Semiconductor Corp.
42 Mactaggart Road #04-01 Mactaggart Building
Singapore 368086
65 287 9705
65 287 9706 Fax
tctee@postone.com

Japan

Pericom Semiconductor Corp.
Yamamasa Daiichi Building 5, 2-11-3 Kobuchi
Sagamihara-shi, Kanagawa 229-0004-Japan
81 427 86 7266
81 427 86 7267 Fax
ksato@pericom.com



ADVANCE INFORMATION

PI7C7100
3-Port PCI Bridge

North America Distributors

Company Name	Street Address	City	State	Zip Code	Country	Telephone	Fax Number
All American	4950 Corporate Drive, Suite 115D	Huntsville	AL	35805	USA	800 382-5303	256-837-7733
Future	6767 Old Madison Pike, Suite 400A	Huntsville	AL	35806	USA	256-971-2010	256-922-0004
Nu Horizons	4825 University Square, Suite 8	Huntsville	AL	35816	USA	256-722-9330	256-722-9348
Pioneer-Standard Electronics	4910 University Square, Suite 7	Huntsville	AL	35816	USA	256-837-9300	256-837-9385
FAI	11219 Financial Centre Parkway, Financial Park Place, Ste 311	Little Rock	AR	72211	USA	501-219-1707	501-219-1747
All American	4636 East University Drive, Suite 155	Phoenix	AZ	85034	USA	480-966-0006	480-966-0007
Bell Microproducts	4926 East McDowell Road, Suite 102	Phoenix	AZ	85008	USA	602-267-9551	602-267-8911
FAI	4636 East University Drive, Suite 145	Phoenix	AZ	85034	USA	480-731-4661	480-731-9866
Future	4636 East University Drive, Suite 245	Phoenix	AZ	85034	USA	602-968-7140	602-968-0334
Nu Horizons	1295 West Washington Street, Suite 212	Tempe	AZ	85281	USA	602-685-9000	602-685-9004
Pioneer-Standard Electronics	4908 East McDowell Road, Suite 103	Phoenix	AZ	85008	USA	602-231-6400	602-321-8877
Aegis Electronics Group	1015 Chestnut Avenue, Suite G2	Charlottesville	VA	92208	USA	760-729-2026	
All American	10805 Holder Street, Suite 100	Cypress	CA	90630	USA	714-229-8600	714-229-8603
All American	14192 Chambers Road	Tustin	CA	92680	USA	714-573-5000	714-573-5047
All American	1545 East Acequia, Suite A	Visalia	CA	93292	USA	209-734-8861	
All American	230 Devcon Drive	San Jose	CA	95112	USA	800-222-6001	408-437-8970
All American	26010 Mureau Road, Suite 120	Calabasas	CA	91302	USA	818-878-0555	818-878-0533
All American	6390 Greenwich Drive, Suite 170	San Diego	CA	92122	USA	800-382-3441	619-598-0201
Bell Microproducts	1921 Ringwood Avenue	San Jose	CA	95131-1721	USA	408-451-9400	408-467-2734
Bell Microproducts	30 Fairbanks, Suite 114	Irvine	CA	92618	USA	949-470-2900	949-470-2929
Bell Microproducts	5090 Shoreham Place, Suite 206	San Diego	CA	92121	USA	858-597-3010	858-597-3015
Bell Microproducts	29800 West Agoura Road, Suite 150	Agoura Hills	CA	91301	USA	818-865-0266	818-865-0215
FAI	354 Bel Marin Keys Blvd., Suite D	Novato	CA	94949	USA	415-883-9446	415-883-8336
FAI	525 South Douglas Street	El Segundo	CA	90245	USA	310-727-1754	310-727-1796
FAI	2220 O Toole Ave.	San Jose	CA	95131	USA	408-434-0369	408-433-9599
FAI	6256 Greenwich Drive, Suite 200	San Diego	CA	92122	USA	858-623-5859	858-623-5860
FAI	25B Technology Drive, Suite 200	Irvine	CA	92618	USA	949-753-4778	949-753-4778
FAI	26570 Agoura Road	Calabasas	CA	91302	USA	818-871-1700	818-871-1726
FAI	3009 Douglas Blvd., Suite 215	Roseville	CA	95661	USA	916-782-7882	916-782-9388
FAI	1370 Valley Vista Drive, Suite 265	Diamond Bar	CA	91765	USA	909-612-0667	909-612-0167
FAI	2121 41st Avenue	Capitola	CA	95010	USA	831-465-7373	831-465-7299
Future	2220 O Toole Ave.	San Jose	CA	95131	USA	408-434-1122	408-433-0822
Future	26570 Agoura Road	Calabasas	CA	91302	USA	818-871-1740	818-871-1764
Future	25B Technology Drive, Suite 200	Irvine	CA	92618	USA	949-453-1515	949-453-1226
Future	27489 West Agoura Road, Suite 300	Agoura Hills	CA	91301	USA	818-865-0040	
Future	3009 Douglas Blvd., Suite 210	Roseville	CA	95661	USA	916-783-7877	916-783-7988
Future	5990 Stoneridge Drive	Pleasanton	CA	94588	USA	925-225-0294	925-225-9745
Future	6256 Greenwich Drive, Suite 200	San Diego	CA	92122	USA	858-625-2800	858-625-2810
Nu Horizons	1220 Melody Lane, Suite 110	Roseville	CA	95678	USA	916-783-5500	916-783-3066
Nu Horizons	13900 Alton Parkway, Suite 123	Irvine	CA	92718	USA	949-470-1011	949-470-1104
Nu Horizons	2070 Ringwood Avenue	San Jose	CA	95131	USA	408-434-0800	408-434-0935
Nu Horizons	4360 View Ridge Avenue, Suite B	San Diego	CA	92123	USA	619-576-0088	619-576-0990
Nu Horizons	850 Hampshire Road, Suite R	Thousand Oaks	CA	91361	USA	805-370-1515	805-370-1525
Pioneer-Standard Electronics	217 Technology Drive, Suite 110	Irvine	CA	92618	USA	949-753-5090	949-753-5074
Pioneer-Standard Electronics	333 River Oaks Pkwy.	San Jose	CA	95134	USA	408-954-9100	
Pioneer-Standard Electronics	5126 Claretton Drive, Suite 100	Agoura Hills	CA	91301	USA	818-865-5800	818-865-5814
Pioneer-Standard Electronics	9449 Balboa Ave., Suite 114	San Diego	CA	92123	USA	858-514-7700	858-514-7799
Pioneer-Standard Electronics	431 Dixon Landing Road	Milpitas	CA	95035	USA	408-586-5600	408-586-5785
All American	7577 West 103rd Avenue, Suite 204	Westminster	CO	80021	USA	303-222-0100	303-222-0110
All American	4090 Youngfield Street	Wheat Ridge	CO	80033	USA	303-422-1701	
Bell Microproducts	4600 South Ulster Street, Suite 240	Denver	CO	80237	USA	303-846-3065	303-846-3064
Future	1819 Denver West Drive, Bldg. 26, Suite 350	Golden	CO	80401	USA	303-277-0023	303-277-0722
Pioneer-Standard Electronics	5600 Greenwood Plaza Blvd. Suite 200	Englewood	CO	80111	USA	303-773-8090	303-773-8194
All American	100 Mill Plain Road, Suite 360	Danbury	CT	06811	USA	203-791-3818	
All American	83 Papermill Road	Woodbury	CT	6798	USA	203-266-0486	same
Future	700 West Johnson Avenue, Westgate Office Center	Cheshire	CT	06410	USA	203-250-0083	203-250-0081
Pioneer-Standard Electronics	Two Trap Falls Road, Suite 100	Shelton	CT	06484	USA	203-929-5600	203-929-9791
All American	600 Fairway Drive, Suite 101	Deerfield Beach	FL	33441	USA	954-429-2800	954-429-0391
All American	528 South North Lake Blvd., Suite 1040	Altamonte Springs	FL	32701	USA	407-261-1304	407-261-1330
All American	14450 46th Street North, Suite 116	Clearwater	FL	33762	USA	813-532-9800	813-538-5567
All American	16115 NW 52nd Avenue	Miami	FL	33014	USA	305-621-8282	305-620-7831
Bell Microproducts	17431 SW 18th Street	Miramar	FL	33029	USA	954-450-1850	954-450-0223
Bell Microproducts	1110 Douglas Avenue, Suite 1018	Altamonte Springs	FL	32714	USA	407-682-1199	407-682-1286
Bell Microproducts	1761 West Hillsboro Blvd., Suite 208	Deerfield Beach	FL	33442	USA	954-429-1001	
Edge Electronics	100 Second Avenue South, Suite 200	St. Petersburg	FL	33701	USA	727-894-3343	727-823-9030
FAI	525 Technology Park, Suites 125/126	Lake Mary	FL	32746	USA	407-333-3177	407-333-3277
FAI	348 SW Miracle Strip Pkwy., Suite 33	Fort Walton Beach	FL	32548	USA	850-301-0766	850-301-0773
FAI	2200 Tall Pines Drive, Suite 109	Largo	FL	34641	USA	727-530-1665	727-530-7609
Future	1400 East Newport Center Drive, Suite 200	Deerfield Beach	FL	33442	USA	954-428-9494	954-428-9477
Future	237 South Westmonte Drive, Suite 307	Altamonte Springs	FL	32714	USA	407-444-6302	407-444-6303
Future	2200 Tall Pines Drive, Suite 108	Largo	FL	33771	USA	727-530-1222	727-538-9598
Nu Horizons	3421 N.W. 55th Street	Ft. Lauderdale	FL	33309	USA	954-735-2555	954-735-2880
Nu Horizons	4500 140th Avenue North, Suites 214/215	Clearwater	FL	33762	USA	727-536-5700	727-536-7799
Nu Horizons	600 South North Lake Blvd., Suite 210	Altamonte Springs	FL	32701	USA	407-831-8008	407-931-8862
Pioneer-Standard Electronics	337 South North Lake, Suite 1000	Altamonte Springs	FL	32701	USA	407-834-9090	407-834-0865
Pioneer-Standard Electronics	674 South Military Trail	Deerfield Beach	FL	33442	USA	954-428-8877	954-481-2950



ADVANCE INFORMATION

PI7C7100 3-Port PCI Bridge



North America Distributors (continued)

Company Name	Street Address	City	State	Zip Code	Country	Telephone	Fax Number
All American	6875 Jimmy Carter Blvd., Suite 3100	Norcross	GA	30071	USA	770-441-7500	770-441-3660
Bell Microproducts	1950 Spectrum Circle, Suite 400	Marietta	GA	30067	USA	770-980-4922	770-857-4399
Future	44000 River Green Parkway, Suite 220	Duluth	GA	30096	USA	770-476-3900	770-476-8662
Future	3150 Hocomb Bridge Rd. Holcolm Place, Suite 130	Norcross	GA	30071	USA	770-441-7676	
Nu Horizons	100 Pinnacle Way, Suite 155	Norcross	GA	30071	USA	770-416-8666	770-416-9060
Pioneer-Standard Electronics	4250-C Rivergreen Pkwy.	Duluth	GA	30096	USA	770-623-1003	770-623-0665
FAI	12438 West Bridger Street, Suite 110	Boise	ID	83713	USA	208-376-8080	208-376-6186
All American	1930 North Thoreau Drive, Suite 200	Schaumburg	IL	60173	USA	847-303-1995	847-303-1996
Bell Microproducts	953 Plum Grove Road, Suite B	Schaumburg	IL	60173	USA	847-413-8530	847-413-8541
FAI	3100 West Higgins Road, Suite 115	Hoffman Estates	IL	60195	USA	847-843-0034	847-843-1163
Future	3100 West Higgins Road, Suite 100	Hoffman Estates	IL	60195	USA	847-882-1255	847-490-9290
Nu Horizons	Baswood Office Center, 500 East Remington Road, Suite 104	Schaumburg	IL	60173	USA	847-519-0700	847-519-7710
Pioneer-Standard Electronics	2171 Executive Drive Suite 200	Addison	IL	60101	USA	630-495-9680	630-495-9831
Future	8520 Allison Pointe Blvd., Suite 310	Indianapolis	IN	46250	USA	317-913-1355	317-913-1375
Future	8425 Woodfield Crossing, Suite 170	Indianapolis	IN	46240	USA	317-469-0447	317-49-0448
Pioneer-Standard Electronics	237 Airport N. Office Park	Fort Wayne	IN	46285	USA	219-489-0283	
Pioneer-Standard Electronics	9350 N. Priority Way W. Drive	Indianapolis	IN	46240	USA	317-573-0880	
All American	7201 West 129th Street, Suite 150	Overland Park	KS	66213	USA	913-851-5900	913-851-5905
FAI	10977 Granada Lane, Suite 210	Overland Park	KS	66211	USA	913-338-4400	913-338-3412
Pioneer-Standard Electronics	8500 College Blvd., Suite 128	Overland	KS	66210	USA	913-338-7164	913-338-7185
All American	19-A Crosby Drive	Bedford	MA	01730	USA	781-275-8888	617-275-1982
Bell Microproducts	2A Gill Street	Woburn	MA	1730	USA	781-933-9010	781-933-8336
Future	41 Main Street	Bolton	MA	01740	USA	978-779-3000	978-779-3050
Interface Electronics	124 Grove Street, Suite 300	Franklin	MA	2038	USA	508-553-4200	508-553-9575
Interface Electronics	228 South Street	Hopkinton	MA	1748	USA	508-435-0100	
Nu Horizons	2 Corporation Way, Suite 240	Peabody	MA	01960	USA	978-532-7666	978-532-7667
Pioneer-Standard Electronics	299 Callardvale Street	Wilmington	MA	01887	USA	978-988-6600	978-988-6620
All American	8310 Guilford Road, Suite A	Columbia	MD	21046	USA	410-309-6262	410-309-6272
Bell Microproducts	6925 R. Oakland Mills Road	Columbia	MD	21045	USA	410-720-5100	410-381-2172
Future	857 Elkridge Landing Road, International Tower	Linthicum	MD	21090	USA	410-314-1111	410-314-1110
Future	6716 Alexander Bell Drive, Suite 220	Columbia	MD	21046	USA	410-290-0600	
Nu Horizons	8965 Guilford Road, Suite 100	Columbia	MD	21046	USA	310-995-6330	310-995-6332
Pioneer-Standard Electronics	9100 Gaither Road	Gaithersburg	MD	20877	USA	301-921-0660	301-670-6746
All American	39201 Schoolcraft Road, Suite B-2	Livonia	MI	48150	USA	734-464-2202	734-464-2433
Future	39340 Country Club Drive, Suite 100	Farmington Hills	MI	48331	USA	248-489-1179	248-489-1030
Future	4595 Broadmoor SE., Suite 280	Grand Rapids	MI	49512	USA	616-534-3510	616-698-6821
Pioneer-Standard Electronics	44190 Plymouth Oaks Blvd.	Plymouth	MI	48170	USA	734-416-2157	734-416-2415
Pioneer-Standard Electronics	44776 Byron Center Road SW	Grand Rapids	MI	49509	USA	616-534-3145	616-534-3922
All American	6608 Flying Cloud Drive	Eden Prairie	MN	55344	USA	612-944-2151	612-944-9803
Bell Microproducts	Primetech Center 1, 6442 City West Parkway, Suite 200	Eden Prairie	MN	55344	USA	612-943-1122	612-943-1110
Future	18882 Lake Drive East	Chanhassen	MN	55317	USA	612-934-9100	612-934-6700
Future	10025 Valley View Road, Suite 196	Eden Prairie	MN	55344	USA	612-944-2200	
Nu Horizons	10907 Valley View Road	Eden Prairie	MN	55344	USA	612-942-9030	612-942-9144
Pioneer-Standard Electronics	7625 Golden Triangle Drive, Suite G	Eden Prairie	MN	55344	USA	612-944-3794	612-829-2229
FAI	12125 Woodcrest Executive Drive, Suite 208	St. Louis	MO	63141	USA	314-542-9922	314-542-9655
Future	12125 Woodcrest Executive Drive, Suite 206	St. Louis	MO	63141	USA	314-469-6805	314-469-7226
Pioneer-Standard Electronics	4227 Earth City Expressway	Earth City	MO	63045	USA	314-209-3000	314-209-3054
All American	1121 Situs Court, Suite 370	Raleigh	NC	27606	USA	919-851-6566	919-851-8734
FAI	5225 Capital Blvd., 1 North Commerce Center	Raleigh	NC	27616	USA	919-790-7111	919-790-9022
FAI	2800 Sumner Blvd., Suite 154	Raleigh	NC	27616	USA	919-876-0088	919-876-8597
Future	8401 University Executive Parkway, Suite 108	Charlotte	NC	28262	USA	704-548-9503	704-548-9469
Interface Electronics	4601 Six Forks Road, Suite 133	Raleigh	NC	27609	USA	919-787-8744	919-787-9192
Nu Horizons	2920 Highwood Boulevard, Suite 125	Raleigh	NC	27604	USA	919-954-0500	919-954-0545
Pioneer-Standard Electronics	5510 Six Forks Road, Suite 310	Raleigh	NC	27609	USA	919-845-5100	919-845-5055
All American	8 East Stow Road, Suite 100	Marlton	NJ	8053	USA	609-596-6666	609-797-1700
Bell Microproducts	55 U.S. Highway 46 East, Suite 403	Pine Brook	NJ	07058	USA	973-244-9668	973-244-9667
Bell Microproducts	23 Sebago Street	Clifton	NJ	7013	USA	201-777-4100	
FAI	2000 Crawford Place, Suite 900	Mt. Laurel	NJ	08054	USA	856-787-1000	856-787-9626
Future	12 East Stow Road, Suite 200	Marlton	NJ	08053	USA	609-596-4080	
Future	1259 Route 46 East	Parisippny	NJ	07054	USA	973-299-0400	973-299-1377
Interface Electronics	20000 Horizon Way, Suite 300	Mt. Laurel	NJ	8054	USA	609-439-0750	609-439-0519
Interface Electronics	1 Green Tree, Suite 201	Marlton	NJ	8053	USA	609-988-5448	
Nu Horizons	18000 Horizon Way, Suite 200	Mt. Laurel	NJ	08054	USA	609-231-0900	609-231-9510
Nu Horizons	39 U.S. Route 46	Pine Brook	NJ	07058	USA	973-882-8300	973-882-8398
Pioneer-Standard Electronics	271 Route 46W, Suite D206	Fairfield	NJ	07004	USA	973-227-7760	973-227-3305
Pioneer-Standard Electronics	14A Madison Road	Fairfield	NJ	7004	USA	201-575-3510	
FAI	5250 Neil Road, Suite 106	Reno	NV	89502	USA	715-826-2500	715-826-2664
All American	275B Marcus Blvd.	Hauppauge	NY	11788	USA	516-434-9000	516-434-9394
All American	333 Metro Park	Rochester	NY	14623	USA	716-292-6700	716-292-6755
Bell Microproducts	1056 West Jericho Turnpike	Smithtown	NY	11787	USA	516-543-2000	516-543-2030
Edge Electronics	2271-7 Fifth Avenue	Ronkonkoma	NY	11779	USA	631-471-3343	631-471-3405
FAI	6245 Sheridan Drive, Suite 216	Williamsville	NY	14221	USA	716-633-7188	716-633-7178
FAI	251 Salina Meadows Parkway, Suite 230	Syracuse	NY	13212	USA	315-451-4405	315-451-2621
Future	251 Salina Meadows Parkway, Suite 210	Syracuse	NY	13212	USA	315-451-2371	315-451-7258
Future	300 Linden Oaks	Rochester	NY	14625	USA	716-387-9600	716-387-9596
Future	3033 Express Drive North	Hauppauge	NY	11788	USA	516-234-4000	516-234-6183



ADVANCE INFORMATION

PI7C7100
3-Port PCI Bridge

North America Distributors (continued)

Company Name	Street Address	City	State	Zip Code	Country	Telephone	Fax Number
Nu Horizons	333 Metro Park	Rochester	NY	14623	USA	716 292-0777	716-292-0750
Nu Horizons	70 Maxess Road	Mellville	NY	11747	USA	516 396-5000	516-396-5050
Pioneer-Standard Electronics	3125 Veterans Memorial Highway, Meridian Plaza III	Ronkonkoma	NY	11719	USA	516 738-1700	516-738-1790
Pioneer-Standard Electronics	1249 UpperFront, Suite 201	Binghamton	NY	13901	USA	607 722-9300	607-722-9562
Pioneer-Standard Electronics	1250 Pittsford/Victor Road, Bldg. 200	Pittsford	NY	14534	USA	716 389-8200	716 389-8240
Pioneer-Standard Electronics	60 Crossways Park West	Woodbury	NY	11797	USA	516 921-8700	
All American	26650 Renaissance Parkway	Warrenville Heights	OH	44128	USA	216 514-0625	216-514-0822
Bell Microproducts	13971 Placid Cove	Strongsville	OH	44136	USA	212 846-9156	212 846-9599
FAI	6009-I Landerhaven Drive	Mayfield Heights	OH	44124	USA	440 446-0061	440-446-0062
Future	1430 Oak Court, Suite 203	Beavercreek	OH	45430	USA	937 426-0090	937-426-8490
Future	6009-E Landerhaven Drive	Mayfield Heights	OH	44124	USA	440 449-6996	440-449-8987
Future	6565 Davis Industrial Parkway, Unit AA	Solon	OH	45430	USA	937 426-0090	937-426-8490
Nu Horizons	2208 Enterprise E. Parkway	Townsburg	OH	44087	USA	330 963-9933	330 963-9944
Pioneer-Standard Electronics	8741 Gander Creek Drive	Miamisburg	OH	45342	USA	937 428-6900	937-428-6995
Pioneer-Standard Electronics	6065 Parkland Boulevard	Mayfield Heights	OH	44124	USA	440 720 8500	440 720 8501
Pioneer-Standard Electronics	6675 Parkland Blvd.	Solon	OH	44139	USA	440 519-6200	440-519-6250
FAI	7030 South Yale, Suite 606	Tulsa	OK	74136	USA	918 492-1500	918-492-4848
Pioneer-Standard Electronics	9717 East 42nd Street, Suite 105	Tulsa	OK	74146	USA	918 665-7840	918-665-1891
All American	1815 NW 169th Place, Suite 1040	Beaverton	OR	97006	USA	503 531-3333	503-531-3695
Bell Microproducts	14780 SW Osprey Drive, Suite 240	Beaverton	OR	97007	USA	503-524-0787	503-524-1075
FAI	7204 SW Durham Road, Suite 900	Portland	OR	97224	USA	503 603-0866	503-603-0960
Future	7204 SW Durham Road, Suite 800	Portland	OR	97224	USA	503 603-0956	503-603-0859
Nu Horizons	15455 NW Greenbrier Parkway, Suite 135	Beaverton	OR	97006	USA	503-439-1200	503-439-6286
Pioneer-Standard Electronics	5665 SW Meadows Road, Suite 150	Lake Oswego	OR	97035	USA	503-968-6565	503-598-2555
Future	103 Bradford Road, Suite 100, Stonewood Commons II	Wexford	PA	15090	USA	724 935-9600	724-935-9695
Pioneer-Standard Electronics	500 Enterprise Road, Kuth Valley Business Center	Horsham	PA	19044	USA	215 674-4000	215 674-3107
Pioneer-Standard Electronics	259 Kappa Drive	Pittsburgh	PA	15238	USA	412 782-2300	412-963-8255
All American	13706 Research Blvd., Suite 103	Austin	TX	78750	USA	512 335-2280	512 335-2282
All American	1771 International Parkway, Suite 101	Richardson	TX	75081	USA	972 231-5300	972 437-0353
Bell Microproducts	12701 Research Blvd., Suite 360	Austin	TX	78759	USA	512 258-0725	512-258-6517
Bell Microproducts	833 East Arapho Road, Suite 205	Richardson	TX	75081	USA	972 783-4191	972-783-4192
Bell Microproducts	2900 Wilcrest, Suite 138	Houston	TX	77042	USA	713 917-0663	713-917-0615
Edge Electronics	1411 LeMay Drive, Suite 204	Carrollton	TX	75007	USA	972 323 7977	972-323-8530
FAI	The Courtyard, 7500 Viscount, Suite C75	El Paso	TX	79925	USA	915 779-7484	
Future	7200 North Mopac, Suite 310	Austin	TX	78731	USA	512-346-6426	512-346-6781
Future	2201 West Plano Parkway, Suite 150	Plano	TX	75075	USA	469 467-0070	469-467-0071
Future	10737 Gateway West, Suite 330	El Paso	TX	79955	USA	915-592-3563	915-592-3818
Future	10333 Richmond Avenue, Suite 970	Houston	TX	77042	USA	713-952-7088	713-952-7098
Future	7500 Viscount, Suite C75	El Paso	TX	79925	USA	915 595-1000	
Future	800 East Campbell Road, Suite 130	Richardson	TX	75081	USA	972 437-2437	
Nu Horizons	1313 Valwood Parkway, Suite 200	Carrollton	TX	75006	USA	972 488-2255	972-488-2265
Nu Horizons	2404 Rutland Drive, Suite 100	Austin	TX	78758	USA	512 873-9300	512-873-9800
Pioneer-Standard Electronics	10707 Corporate Drive, Suite 106	Stafford	TX	77477	USA	281-240-4882	281-240-7897
Pioneer-Standard Electronics	13765 Beta Road	Dallas	TX	75244	USA	972-419-5500	972-490-6419
Pioneer-Standard Electronics	4030 West Breaker Lane, Suite 175	Austin	TX	78759	USA	512 340-9500	512-340-9552
Pioneer-Standard Electronics	959 East Collins Blvd., Suite 102	Richardson	TX	75081	USA	972-808-1900	972-808-1940
All American	6955 South Union Park Center, Suite 110	Midvale	UT	84047	USA	801-565-8300	801-565-9983
Bell Microproducts	384 North Main Street	Centerville	UT	84014	USA	801-295-3900	801-295-3377
Future	3450 South Highland Drive, Suite 303	Salt Lake City	UT	84106	USA	801 467-9696	801-467-9755
Pioneer-Standard Electronics	6925 Union Park Center, Suite 600-24	Midvale	UT	84047	USA	801-566-8692	801-566-8719
Bell Microproducts	1039 Sterling Road, Suite 204	Herndon	VA	20170	USA	703 834-3696	703-834-3698
FAI	660 Hunters Place, Suite 202	Charlottesville	VA	22911	USA	804 984-5022	
All American	11807 North Creek Pkwy South, Suite 112	Bothell	WA	98011	USA	425-806-4800	425-806-9900
FAI	12100 NE 195th Street, Suite 150	Bothell	WA	98011	USA	425-485-6616	425-483-6109
Future	19102 North Creek Parkway, Suite 118	Bothell	WA	98011	USA	425 489-3400	425-489-3411
Nu Horizons	8417 154th Avenue NE	Redmond	WA	98052	USA	425-861-9200	425-861-9800
Pioneer-Standard Electronics	2800 156th Avenue SE, Suite 205	Bellevue	WA	98007	USA	425-644-7500	425-644-7300
All American	18000 Sarah Lane, Suite 145	Brookfield	WI	53045	USA	414 792-0438	414-792-9733
FAI	175 North Corporate Drive, Suite 150	Brookfield	WI	53045	USA	414-792-9778	414-792-9779
Future	250 N. Patrick Blvd., Suite 170	Brookfield	WI	53045	USA	414 879-0244	
Pioneer-Standard Electronics	120 Bishops Way, Suite 163	Brookfield	WI	53005	USA	414-780-3600	414-780-3613



ADVANCE INFORMATION

PI7C7100
3-Port PCI Bridge

North America Representatives

Company Name	Street Address	City	State	Zip Code	Country	Telephone	Fax Number
BITS, Inc.	2705 Artie St., Suite 29	Huntsville	AL	35805	USA	256534-4020	256534-0410
Neutronics Components Ltd.	2062723-37th Avenue NE	Calgary	Alberta	T1Y 5R8	CANADA	4032914994	403291-4717
Scheffler-Kahn Company, Inc.	21639 North 12th Avenue, Suite 105	Phoenix	AZ	85027	USA	623581-0884	623581-3522
DynaRep	2985 E. Hillcrest Drive, Suite 201	Thousand Oaks	CA	91362	USA	8057771185	805777-9266
DynaRep	3002 Dow Avenue, Suite 226	Tustin	CA	92780	USA	7145731223	714573-0778
Innovation Sales	6440 Lusk Blvd., Suite D200	San Diego	CA	92121	USA	858-535-9300	858-550-3707
NCTR	46750 Fremont Blvd., Suite 110	Fremont	CA	94538	USA	510624-8900	510624-8905
Electrodyn	2620 South Park Road, Suite 395	Aurora	CO	80014	USA	303-695-8903	303745-8924
Component Design Marketing	1803 Park Center Drive, Suite 200	Orlando	FL	32835	USA	407-522-5808	407-522-0774
Component Design Marketing	2240 Woolbright Road, Suite 317	Boynton Beach	FL	33426	USA	561740-3335	561740-3635
BITS, Inc.	5425 Sugarloaf Pkwy., Suite 2201	Lawrenceville	GA	30043	USA	770-513-8610	770-513-8680
Luscombe Sales	6901 Emerald, Suite 206	Boise	ID	83704	USA	208-377-1444	208-377-0282
Martan, Inc.	1100 Woodfield Road	Schaumburg	IL	60173	USA	8473303200	
Oasis Sales Corporation	1101 Tonne Road	Elk Grove Village	IL	60007	USA	8476401850	847-640-9432
Martan, Inc.	10820 Horton	Overland Park	KS	66211	USA	9133813652	913381-3653
Universal Technology	22 A Street	Burlington	MA	3803	USA	781-890-8523	781-890-8589
Avtek Associates	10632 Little Patuxent Parkway, Suite 435	Columbia	MD	21044	USA	410740-5100	410-740-5103
Jay Marketing Assoc. Inc.	44752 Helm Street	Plymouth	MI	48170	USA	734-459-1200	734-459-1697
Cahill, Schmitz & Cahill, Inc.	897 St. Paul Avenue	St. Paul	MN	55116	USA	6516990200	651-699-0800
Martan, Inc.	257 Old Stone Court	O'Fallon	MO	63366	USA	3149393300	314-447-1371
BITS, Inc.	940 Main Campus Drive, Suite 120	Raleigh	NC	27606	USA	9198071000	919-807-1001
BITS, Inc.	3320 Silver Pond Court	Charlotte	NC	28810	USA	704-540-8185	704-540-8183
Matrix Sales	30 Washington Avenue Suite B-2	Haddonfield	NJ	8033	USA	8567958833	8567950038
Neptune Electronics/NECCO	11 Oval Drive, Suite 169	Islandia	NY	11722	USA	631-234-2525	631-234-2707
NYCOM, Inc.	10 Adler Drive	East Syracuse	NY	13057	USA	315437-8343	315-437-1208
Electronic Device Sales	8000 Green Ridge Court	Mentor	OH	44060	USA	440255-7040	440-255-7093
Electronic Device Sales	6917 Rob Vern Drive	Cincinnati	OH	45239	USA	513729-8440	513-729-8448
Nova Marketing Ltd.	3544 Adams Road	Mounds	OK	74074	USA	918-827-5560	918827-5561
Neutronics Components Ltd.	232 Herzberg Road, Suite 201	Kanata	Ontario	K2K2A1	CANADA	613599-1263	613-599-4750
Neutronics Components Ltd.	240 Terence Mathews Crescent, Suite 105	Kanata	Ontario	K2M2C4	CANADA	6135991263	
Neutronics Components Ltd.	6271 Dorman Road, Suite 18	Mississauga	Ontario	L4V 1H1	CANADA	9056714001	905671-4062
Electra	6700 SW 105th Avenue, Suite 210	Beaverton	OR	97008	USA	5036435074	503526-2055
Astroprep Mid Atlantic Inc.	65 West Street Road, Suite B-203	Warminster	PA	18974	USA	2159579580	
Neutronics Components Ltd.	189 Hymus Blvd., Suite 604	Pointe Claire	Quebec	H9R 1E9	CANADA	5144285838	514-428-5837
Nova Marketing Ltd.	10701 Corporate Drive, Suite 370	Stafford	TX	77477	USA	214-265-4600	214-265-4668
Nova Marketing Ltd.	127 Pioneer Plaza at 127 San Francisco	El Paso	TX	79901	USA	915543-3212	915-543-3213
Nova Marketing Ltd.	3520 Executive Center Drive, Suite 159	Austin	TX	78731	USA	512343-2321	512-343-2487
Nova Marketing Ltd.	508 Twilight Trail, Suite 203	Richardson	TX	75080	USA	214-570-3430	214-570-3435
Luscombe Sales	670 East 3900 South, Suite 103	Salt Lake City	UT	84107	USA	801268-3434	801266-9021
Electra	11411 NE 124th Street, Suite 285	Kirkland	WA	98034	USA	4258217442	425821-7289
Oasis Sales Corporation	1305 N. Barker Road	Brookfield	WI	53045	USA	2627826660	262782-7921



ADVANCE INFORMATION

PI7C7100
3-Port PCI Bridge

International Distributors

Company Name	Address	Country	Telephone
All American	Ave. Mariano Otero, #3431 Ber Pisco, Col. Verde Valle, Guadalajara, Jalisco, 44550	MEXICO	011 5238184302,
All American	6375 Dixie Road, Units 4,5,6, Mississauga, ON, L5T 2E7	CANADA	905670-5946
FAI	3689 East 1st Ave., Suite 200, Vancouver, Br. Colum., V5M 1C2	CANADA	604654-1050
FAI	1780 Wellington Avenue, Suite 504, Winnipeg, Manitoba, R3H 1B2	CANADA	204-786-3075
FAI	1000 St. Charles Blvd., 10th Floor, Vaudreuil, Quebec, J7V 8P5	CANADA	514457-1487
FAI	1000 St. Charles Blvd., 1st Floor, Vaudreuil, Quebec, J7V 8P5	CANADA	5144573004
FAI	1101 Prince of Wales, Suite 210, Ottawa, Ontario, K2C3W7	CANADA	6137278622
FAI	1144 29th Avenue NE, Suite 200, Calgary, Alberta, T2E 7P1	CANADA	4032915333
FAI	5935 Airport Road, Suite 205/210, Mississauga, Ontario, L4V 1W5	CANADA	9056129888
FAI	237 Hymus Blvd., Point Claire, Quebec, H9R 5C7	CANADA	514694-7710
FAI	6029 103rd Street, Edmonton, Alberta, T6H2H3	CANADA	7084385888
Future	1000 St. Jean Baptiste, Suite 201, Quebec, Quebec, G2E 5G5	CANADA	418877-1414
Future	1101 Prince of Wales, Suite 210, Ottawa, Ontario, K2C3W7	CANADA	6137271800
Future	1144 29th Avenue NE, Suite 200, Calgary, Alberta, T2E 7P1	CANADA	403-219-3443
Future	26 Merchants Square, Ennis, Country Clare	IRELAND	3536541330
Future	3689 East 1st Avenue, Suite 200, Vancouver, Br. Colum., V5M 1C2	CANADA	6042941166
Future	5, Avenue Albert Durand, Aeropole 3, 31700 Blagnac, Toulouse	FRANCE	33562747240
Future	Black and Decker Str. 17b, Idstein, 65510	GERMANY	0612693210
Future	Buschkamp 84, Langenhagen, 30853	GERMANY	0511725620
Future	Europarc du chene/4 Rue Edison, 69674 Bron Cedex, Lyon	FRANCE	44372158600
Future	Hauert 8, Dortmund, 44227	GERMANY	02319750480
Future	Johannes-Daur Str. 1, Korntal-Munchigen, 70825	GERMANY	0711830830
Future	Kanalvagen 10C, 18461 Upplands Vasby	SWEDEN	0046559004183
Future	Luxemburger Str. 35, Berlin, 13353	GERMANY	0304690890
Future	Max-Weber-Strabe 3, Quickborn, 25451	GERMANY	0410677480
Future	Munchner Strabe 18, Unterforhring, 85774	GERMANY	089957270
Future	Parc Technopolis/L.P. 854 les Ulis, 3, Ave. du Canada/ Bat Theta 2, Courtaubef, Cedex, Paris, 91974	FRANCE	33169821111
Future	Unit 4 Blair Court, Clydebank Bus. Park, Clydebank, Glasgow, G811 2RX	UK	0419511199
Future	Urb. Belmonte Galicia #45, Mayaguez, 00680	Puerto Rico	787289-7801
Future	Via Fosse Ardeatine 4, 20092 Cinisello Balsamo, Milan	ITALY	392660941
Future	Wilhelm-Wolff Str. 6, Erfurt, 99099	GERMANY	0361420870
Future Electronics OY	Olarinluoma 7, Fon-02200, Espoo, Helsinki	FINLAND	01135895259950
Future Electronics	Distribution (Spain), S.L., Avenida D=dek, Oarebib 8-10, Madrid	SPAIN	3417210762
Future Electronics	Faerch-Huset, L1/ Ostergade 5.4, DK-7500 Holstebro	DENMARK	4596100961
Future Electronics AS	GPI Building, Karihaugveien 89, 1086 Oslo	NORWAY	0114722905800
Future Electronics B.V.	Tinstraat 3, 4823AA Breda	Netherlands	01131645712497
Future Electronics Inc.	103 Medinat Hayeudim Street, P.O. Box 2219, Herzliya, 46120	ISRAEL	972999586555
Future Electronics KFT- Hungary	Burokutca 34, J-1124, Budapest	HUNGARY	0113614585690
Future Electronics Polska	Spolka z.o.o U1 Panienska 9, 03-704 Warsaw	POLAND	01148226189202
Future Electronics SRL	Galleria Camillo Ronzani 3/9, Casalecchio Di Reno, Bologna, 40033	ITALY	0516136700
Future Electronics SRL	Via Domenico Turazza, 30, 31528 Padova	ITALY	04989920111
Future Electronics De Mexico	Calle Paplot #92 Bis, Col. San Martin, Xochinahuac, Mexico, D.F., 2210	MEXICO	5-382-4106
Future Electronics De Mexico	Chimalhuacan #3569, 4 Piso, Suite 6 Ciudad Del Sol, Zapopan, Jalisco, 45050	MEXICO	011523122-0043
Future Electronics De Mexico	Col. Bosques del Alba, Cuautitlan, Ixcalli, Estado De Mexico, 54769	MEXICO	58935764
Future Electronics De Mexico	Futbol #173-11, Col. Country Club, Mexico, D.F., 04220	MEXICO	56893340
Future Electronics De Mexico	Torre Gia Piso 8, Av. Morones Prieto, #2805 Pte., Col. Loma Larga, Monterrey, N.L., 64710	MEXICO	8-399-0027
Future-Birmingham	1st Floor 3 Hagley Court North, Waterfront East, Brierley Hill, W. Midlands, DY5 1XF	UK	01384482555
Future-Brazil	Rua Luzitana, 740 10 Andar, Conj 103/104, 13014-121, Campinas, SP	BRAZIL	01155192321511
Future-Manchester	Adamson House, Throstle nest Lane, Pomona Strand, Manchester, M16 0TT	UK	4461876000
Pioneer-Standard Canada	10711 Cambie Road, Suite 170, Richmond, BC, V6X 3G5	CANADA	604273-5575
Pioneer-Standard Canada	223 Colonnade Road, Unit 100, Nepean, ON, K2E 7K3	CANADA	613226-8840
Pioneer-Standard Canada	148 York Street, Suite 209, London, ON, N6A 1A9	CANADA	905-405-8300
Pioneer-Standard Canada	240 Graham Avenue, Suite 808, Winnipeg, Manitoba, R3C 0J7	CANADA	204989-1957
Pioneer-Standard Canada	3415 American Drive, Mississauga, ON, L4V 1T6	CANADA	905405-8300
Pioneer-Standard Canada	520 McCaffrey Street, Ville St. Laurent, QC, H4T 1N1	CANADA	514737-9700
Pioneer-Standard Canada	Place Iberville IV, 2954 Blvd. Laurier, Suite 100, Ste. Foy, QC, G1V 4T2	CANADA	418654-1078
Pioneer-Standard Electronics	Kuth Valley Bus. Ctr, 500 Enterprise Road, Horsham, PA, 19044	CANADA	215674-4000



ADVANCE INFORMATION

**PI7C7100
3-Port PCI Bridge**

International Representatives

Company Name	Address	Country	Telephone
Acetronix	1st Floor Ashville Palace 31-13 Hap-Dong, Sudaimoon-Ku, SEOUL, 120-030	KOREA	82-2-796-4561
Alcom Electronics	Single 3, 2550 Kontich Belgium	BELGIUM	011 3234583033
Alcom Electronics BV	Rivian le straat 52, 2909 LE, Capelle aan den Yssel	Netherlands	31 10 28 82 500
Ambar Cascom, Ltd.	The Gatehouse, Alton House Business Park, Gatehouse Way, Aylesbury Bucks, HP193DL	UK	01296-434141
Boran Technologies Ltd.	Dynacom Division, P.O. Box 2627, Petach Tikva, 49125	ISRAEL	972-3927-4747
Braemac Pty. Ltd.	Unit 1, 59-61 Burrows Road, Alexandria NSW, 2015	AUSTRALIA	612 9550 6600
Chin Shang Electronics Corp.	4F, No. 18, Alley 1, Lane 768, Sec 4, Pa Te Road, Taipei	TAIWAN	886-2-2-7885470
Communica (PTY) Ltd.	Sunnyside 0132 Pretoria 0002	South Africa	011 27 12 3327613
Component Design Marketing	Calte Huca #38 Bajos BO Sabanetas Mercedita Dr. 00715	Puerto Rico	787 844-3840
Deitek	Block 1 Unit A3, Templeton Bus. Centre, Templeton St., Glasgow, G40 1DA	SCOTLAND	0141-556-7233
Desner Electronics Co. Ltd.	4th Floor, Na-Nakorn Building, 99/349 Changwattana Rd. 10210 Bangkok, Laksi, Bangkok, 10210	THAILAND	662-576 1500-1
Desner Electronics, Far East PTE, Ltd.	42 Mactaggart Road, #04-01, Mactaggart Building, Singapore, 368086	SINGAPORE	65-2851566
Desner SDN BHD	No.9, Jalan PJS8/9, Bandar Sunway, 46150 Selangor, Kuala Lumpur, 46150	MALAYSIA	603-7877 6211
Desner SDNBHD	No.36B Jalan Tun Dr. Awang 11900 Pulau Pinang, Pulau Pinang, 11900	MALAYSIA	604-641-1288
EEC International (HK) Ltd.	Room 805 8/f Hunghom Comm. Ctr., Tower B, 37-39 Ma Tau Wai Road, Hunghom, Kowloon	Hong Kong	011 852 2365 7775
EEC Technology (S) Pte. Ltd.	10 Upper Ajunied Link, #04-01, York Intl Industrial Bldg., Singapore, 367904	SINGAPORE	65 283 0822
Elitron Electronic Co. Ltd	4F, 70 Cheng Kung Road, Section 1, Nankang, Taipei	Taiwan, R.O.C.	011 886 227893300
Elitron Electronic Co. Ltd.	4F, 70 Cheng Kung Road, Section 1, Nankang, Taipei	Taiwan, R.O.C.	011 886 227893300
EPCO Technology Co., Ltd.	10 F, 268, Sec. 2, Fu-Hsing S. Rd., Taipei	TAIWAN	886 2 2737 3507
FMG Electronics Ltd.	Garden Row, William Street, Kilkenny	IRELAND	353-56-64002
GD Technik	Tudor House, 24 High Street, Twyford Berks, RG10 9AG	UK	011441189342277
GD Technik	Unit 20, Blackburn Technology Mgmt. Centre, Challenge Way, Blackburn, BB1 5QB	UK	01254679831
Golden Rich Technologies	Unit 1006, 10/F Tower II, Enterprise Square, 9 Sheung Yuet Road, Kowloon Bay	HONG KONG	852 2751-8840
Heko Electronikk & Data a/s	L-rdagsrudeveien 24, Fjellhamar, 1472	NORWAY	47-67-90-52-44
Hy-Line Computer Components	Inselkammerstrasse 10, Unterhaching, 82008	GERMANY	011-49-89-614503-40
I&C Microsystems, Co. Ltd	8th Floor, Bethel Bldg., 324-1, Yangjae-Dong, Seocho-Ku, SEOUL	KOREA	82-2-577-9131
Internix Inc. (Hachioji Branch)	59-10 Takakura-cho, Hachioji-shi, Tokyo, 192-0033	JAPAN	81-426-448786
Internix Inc. (Head Office)	Shinjuku Hamada Bldg., 3F 7-4-7, Nishishinjuku, Shinjuku-ku, Tokyo, 160-8388	JAPAN	81-3-3369-1105
Leading Technologies	99 Route de Versailles, Champlan, 91160	FRANCE	33 01 69 79 9350
Leading Technologies Italia SRL	Via Flume 13, 1-20059 Vimercate (MI)	ITALY	39 39 66 13 108
MCM Japan Ltd.	2-11-2 Sun Tower Center Bldg., Sangenjaya, Setagaya-Ku, Tokyo, 154-8539	JAPAN	81-3-3487-8477
Micro Summit K.K.	Premier KI Building, 1 Kanda, Mikura-cho, Chiyoda-ku, Tokyo, 101-0038	JAPAN	03-3258-5531
Micro Summit Singapore Pte. Ltd	Blk 13 Braddell Tech, #03-02, Toa Payoh Lorong 8, Singapore, 319261	SINGAPORE	65-2522677
Microelectronic Visions Inc.	2812 Garden Creek Circle, Pleasanton, CA, 94588	UK	510 485-0710
Milgray Distribution GMBH	Allmendstrasse 28, PO Box 68, 2562 Port Switzerland	SWITZERLAND	011 41 3233 12064
Neutronics Components Ltd.	189 Hymus Components, Suite 604, Pointe Claire, Quebec, H9R 1E1	CANADA	514 428 5838
Neutronics Components Ltd.	206 2723-37th Avenue NE, Calgary, Alberta, T1Y 5R8	CANADA	403 291 4994
Neutronics Components Ltd.	240 Terence Matthew's Crescent, Suite 105, Kanata, Ontario, K2M 2C4	CANADA	613 599 1263
Neutronics Components Ltd.	6271 Dorman Road, Unit # 18, Mississauga, Ontario, L4V 1H1	CANADA	905 671 4001
Newtek	8 Rue De L'Estere, Silic 583, Rungis Cedex, 94663	FRANCE	1-468-72200
Newtek Italia SpA	Via Cassiodoro 16, Milano, 20145	ITALY	02-4692156
Pan American Technical Sales	Av. Avila Camacho No. 2275-1, Col. Country Club, C.P. 44610, Zapopan, Jalisco	Mexico	011 52 3 824 9999
Pan American Technical Sales	6624 Cresta Bonita, El Paso, TX, 79912	USA	915 532 1900
Pan American Technical Sales	Av. Morones Prieto #2805 Pte. Col. Loma Largo, C.P. 64710, Monterrey, Nuevo Leon	Mexico	011 52 8 399 0024
Pan American Technical Sales	8100 Shoal Creek Blvd., Suite 250, Austin, TX, 78757	USA	512 371 7272
Pangaea International Trading Corp.	Unit 703, Alabang Business Center, Madrigal Business Park, Ayala Alabang, Muntinlupa City, 1780	PHILIPPINES	632 807 8429
RTI Industries Co., Ltd.	Room 402, Nan Fung Commercial Centre, No 19, Lam Lok Street, Kowloon Bay	HONG KONG	852-279-57421
Silicon Concepts	PBC LYNCHBOROUGH ROAD, PASSFIELD, LIPHOOK, Hampshire, HAMPSHIRE	UK	01428751617
Silicon Highway	4B Saturn House, Calieva Park, Aldermaston, Berkshire, RG7 8HA	UK	01189816888
Spectra Innovations Inc.	780 Montague Expressway, Suite 208, San Jose, CA, 95131-1316	USA	(408) 954-8474
Spectra Innovations Inc.	S-822, Manipal Centre, 47, Dickenson Road, Bangalore, 560 042	INDIA	91-80-558-8323
Sunrise Corporation	Unit 802, Daesung Bldg. 775-3 Daerim-3dong, Youngdeungpo-Ku, SEOUL	KOREA	822 844 2328
Techmosa International Inc.	4F, No. 18, Alley 1, Lane 768, Sec 4, Pa Te Road, Taipei	TAIWAN	886-2-2-7822288



ADVANCE INFORMATION

PI7C7100
3-Port PCI Bridge

NOTES



ADVANCE INFORMATION

PI7C7100
3-Port PCI Bridge

NOTES