

**KEC**

KOREA ELECTRONICS CO.,LTD.

**SEMICONDUCTOR  
TECHNICAL DATA**

**KIA6035P**

BIPOLAR LINEAR INTEGRATED CIRCUIT

AM TUNER SYSTEM FOR CAR AUDIO

The KIA6035P is a high performance AM electronic tuner IC that is greatly improved in cross modulation characteristic. It is especially suited for use in car radio and home stereo (antenna:loop) applications.

FUNCTIONS

- MIX   •OSC(with ALC)   •IF amp   •Detector
- AGC(normal)   •RF wide band AGC
- Auto search stop signal (signal meter output)
- Local oscillation buffer output   •Others

FEATURES

- Excellent cross modulation characteristic.
- The narrow-band signal meter output is usable as auto search stop signal.
- Local oscillation buffer output.
- The OSC with ALC improves tracking error.
- Double-balanced differential mix.
- Low Noise : 56dB(Typ.).
- Usable Sensitivity : 25dBμ (at S/N=20dB)
- Wide Supply Voltage : V<sub>cc</sub>=7.5V~12V.

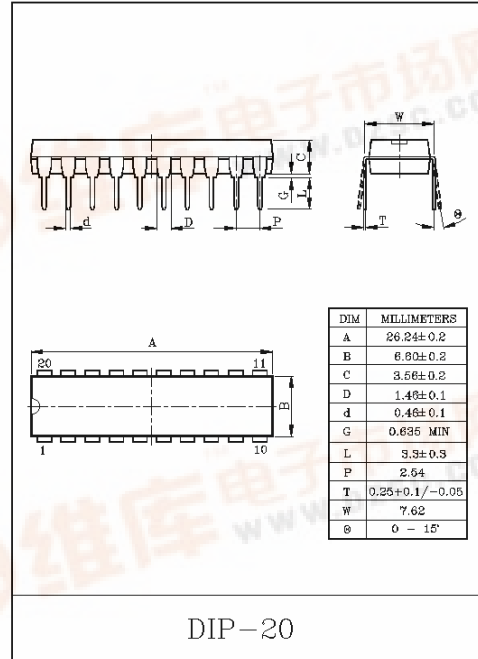

MAXIMUM RATINGS (Ta=25°C)

CHARACTERISTIC	SYMBOL	RATING	UNIT
Supply Voltage	V <sub>cc</sub>	16	V
Output Voltage	V <sub>out</sub>	24	V
Input Voltage	V <sub>IN</sub>	5.6	V
Supply Current	I <sub>cc</sub>	41	mA
Flow-Out Current	I <sub>13</sub>	2	mA
	I <sub>20</sub>	2	
Power Dissipation	P <sub>D</sub>	730	mW
Operating Temperature	T <sub>opr</sub>	-30~85	°C
Storage Temperature	T <sub>stg</sub>	-55~150	°C



# KIA6035P

## ELECTRICAL CHARACTERISTICS

(Ta=25°C, Vcc=8V, f=1MHz, fm=400Hz, Mod=30%)

CHARACTERISTIC	SYMBOL	TEST CONDITION	MIN.	TYP.	MAX.	UNIT
Quiescent Supply Current	I <sub>CCQ</sub>	-	13.5	22.5	32.5	mA
Supply Current	I <sub>CC</sub>	V <sub>IN</sub> =130dBμ	20.0	30.0	41.0	
Detection Output	V <sub>OD1</sub>	V <sub>IN</sub> =16dBμ	-29.0	-25.0	-21.0	dBm
	V <sub>OD2</sub>	V <sub>IN</sub> =74dBμ	-15.0	-12.0	-9.0	dBm
Signal to Noise Ratio	S/N	V <sub>IN</sub> =74dBμ	51.0	56.0	-	dB
Total Harmonic Distortion	THD1	V <sub>IN</sub> =74dBμ	-	0.3	1.0	%
	THD2	V <sub>IN</sub> =74dBμ, Mod=80%	-	0.3	1.0	%
	THD3	V <sub>IN</sub> =130dBμ, Mod=80%	-	0.4	2.0	%
Signal Meter Output	V <sub>SM1</sub>	Quiescent	-	0	0.3	V
	V <sub>SM2</sub>	V <sub>IN</sub> =130dBμ	3.0	5.0	7.5	V
Input Voltage at Signal Meter Output 1V	V <sub>IN(1)</sub>	V <sub>SM</sub> =1V	18.0	24.0	30.0	dBμ
Local OSC Buffer Output	V <sub>OSC(BUF)</sub>	-	320	380	-	mV <sub>rms</sub>
Usable Sensitivity	Q.S.	S/N=20dB	-	25.0	-	dBμ
Detection Output Variation	ΔV <sub>OD</sub>	V <sub>IN</sub> =74dB~130dBμ	-	0.2	-	dB
Wide-Band AGC ON State Input	WB <sub>AGC</sub>	Interference 1.4MHz non mod. Reception 1.0MHz Quiescent Input for ANT Damping ON.	-	82.0	-	dBμ
Local OSC Variation Within broadcast band	ΔV <sub>OSC</sub>	V <sub>OSCL</sub> -V <sub>OSCH</sub>	-	15	-	mV <sub>rms</sub>
Signal Meter Band Width	BW <sub>SM1</sub>	V <sub>IN</sub> =74dBμ, frequency at which output is reduced to 1/2	-	±1.5	-	kHz
	BW <sub>SM2</sub>	V <sub>IN</sub> =74dBμ, frequency at which output is reduced to 1/10	-	-45/+7	-	kHz
Selectivity	Se1	f= ±10kHz, WB <sub>AGC</sub> :"OFF"	-	43	-	dB
IF Interference	IF <sub>I</sub>	f=600kHz, WB <sub>AGC</sub> :"OFF"	-	77.5	-	dB
Image Frequency Interference	IM <sub>I</sub>	f=1400kHz, WB <sub>AGC</sub> :"OFF"	-	52.0	-	dB

# KIA6035P

## BLOCK DIAGRAM

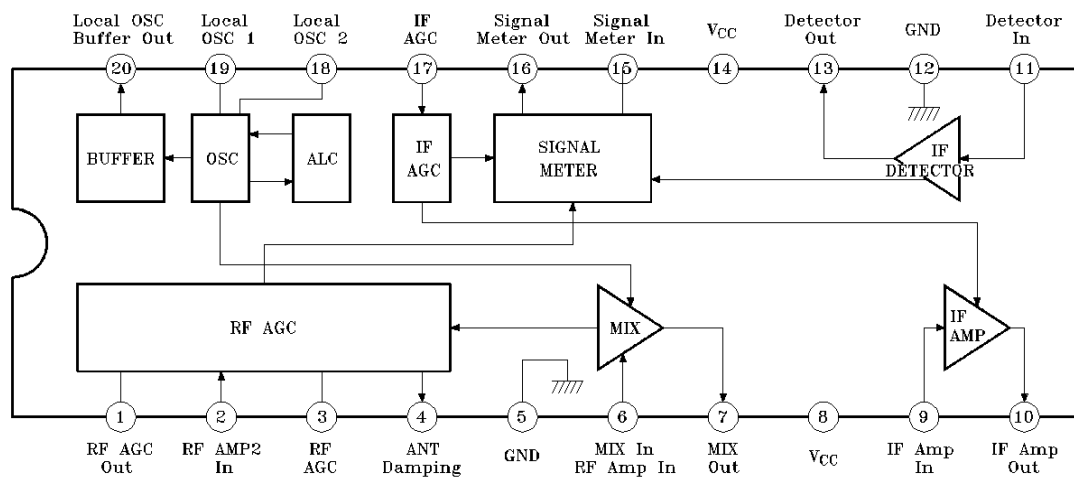

## TEST CIRCUIT

$V_{CC}=8V$ ,  $f=1MHz$ ,  $f_m=400Hz$

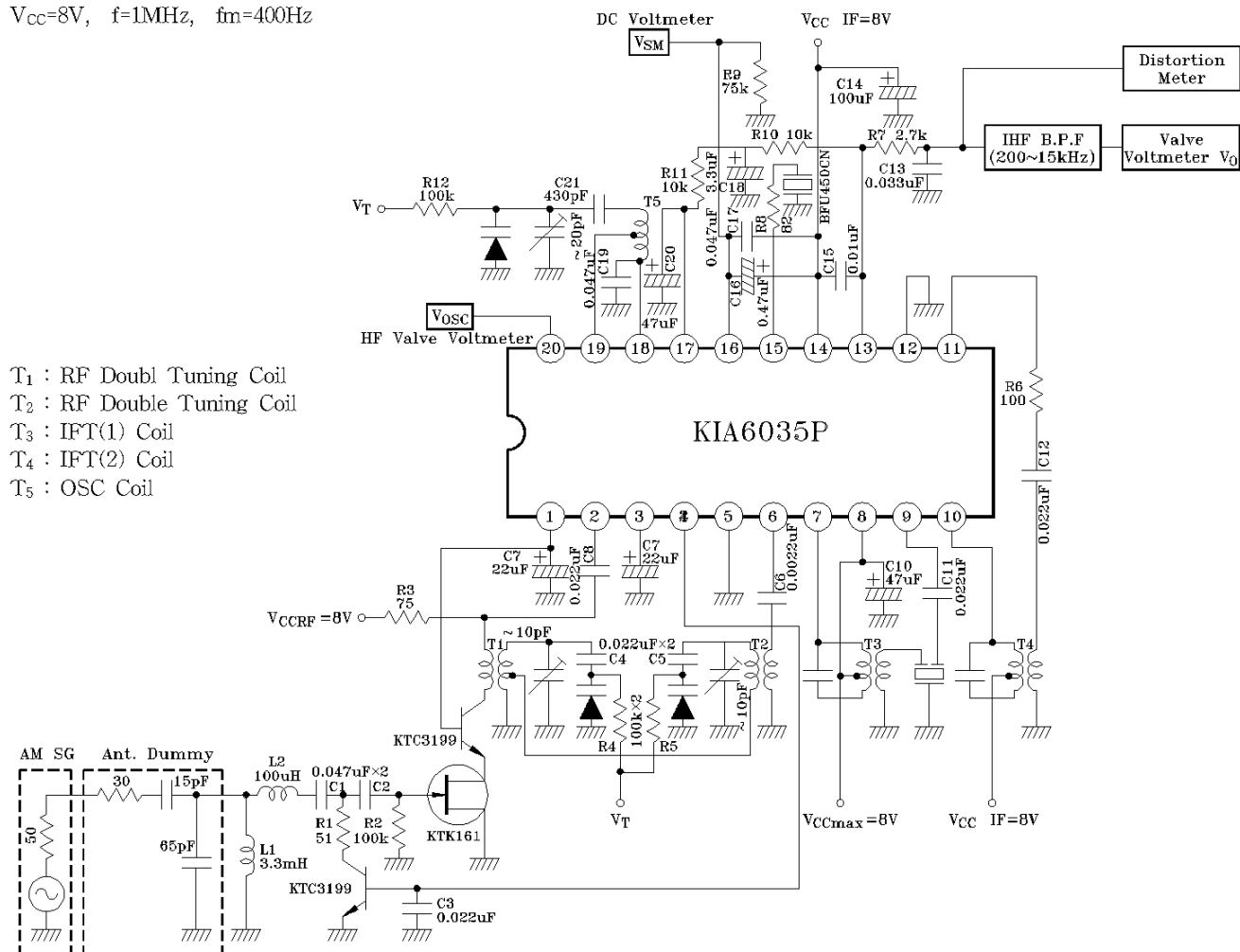

- T<sub>1</sub> : RF Doubl Tuning Coil
- T<sub>2</sub> : RF Double Tuning Coil
- T<sub>3</sub> : IFT(1) Coil
- T<sub>4</sub> : IFT(2) Coil
- T<sub>5</sub> : OSC Coil

# KIA6035P

## APPLICATION INFORMATION

1. Bias condition : RF  $V_{CC} \leq$  IF  $V_{CC}$
2. Avoid coupling between the antenna tuning circuit and the local oscillator.
3. Connect detection capacitor  $C_{15}$  across pins 13(output) and 14( $V_{CC}$ ) so that no leakage of the IF signal to the GND line occurs. (If connected to GND, the tweet and the usable sensitivity may get worse.) Radiation from  $C_{15}$  may cause harmonics in the IF signal to return to the RF stage, thereby leading to more tweet interference. So, connect  $C_{15}$  as close to pins 13,14 as possible. Consider the direction of the capacitor and separate it from the ANT circuit.
4. For  $R_9$ , use a semifixed resistor with  $V_{SM}$  considered.
5. When designing the coils, consider the following conditions.  
The table is the input level at each pin at which the detection output as  $f_m=400\text{Hz}$ , 300% mod becomes -25dBm.

Table

stage	ANT	MIX	IF	DET
Input Level (dB $\mu$ )	16.0	28.0	45.0	61.0

Each stage is applied Input as shown below.

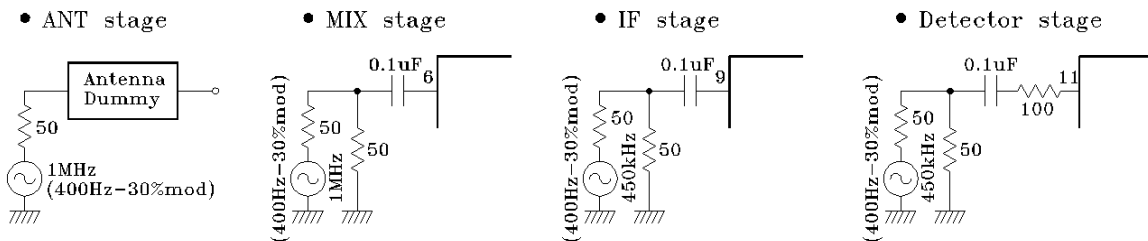

## 6. ANT damping

To make the ANT damping constant within the receiving band, change the application circuit as shown below.

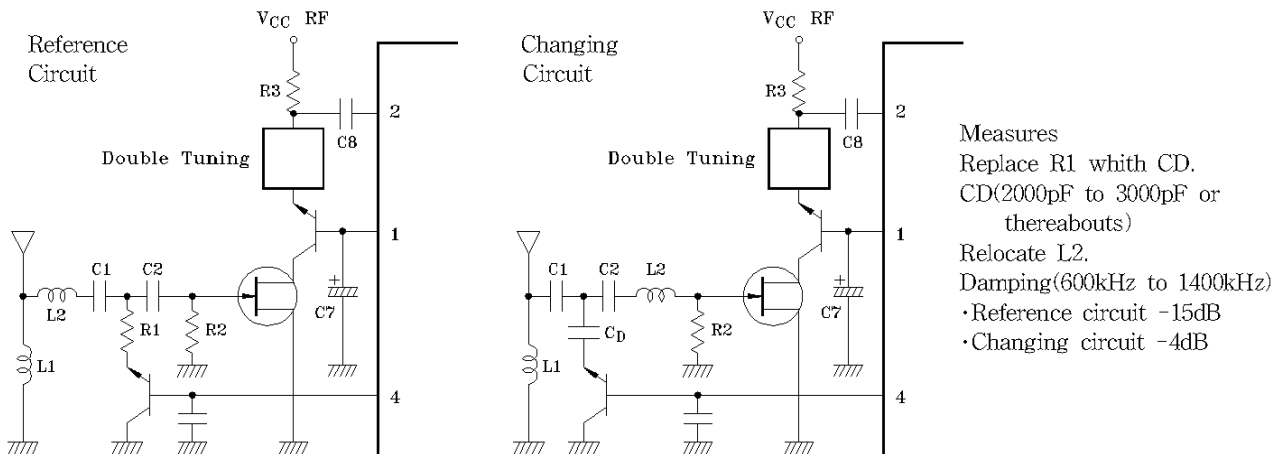

# KIA6035P

## 7. Meaning of $L_2$

If the RF stage is double-tuned, the difference in sensitivity within the RF band almost disappears, but an antiresonance point of approximately 20MHz appears, thereby leading to worse spurious characteristic. So,  $L_2$  is used to remove the SW band.

## 8. Wide-band AGC

This IC contains 2-channel wide-band AGC. Pin 6 detects an undesired signal within the RF band and wide-band AGC is applied. This detection sensitivity is determined inside the IC. Pin 2 detects an undesired signal outside the RF band. This detection sensitivity is determined by R3. When  $1mV_{rms}(f=1MHz)$  signal is applied to pin 2, AGC operates.

## 9. Measures against suppression of sensitivity

In the AGC circuit of the test circuit the presence of an undesired signal of high strength within the receiving band may cause the desired signal to be suppressed when the desired signal is low or medium in strength. Shown below is the circuit configuration where the necessary measures are taken against this suppression.

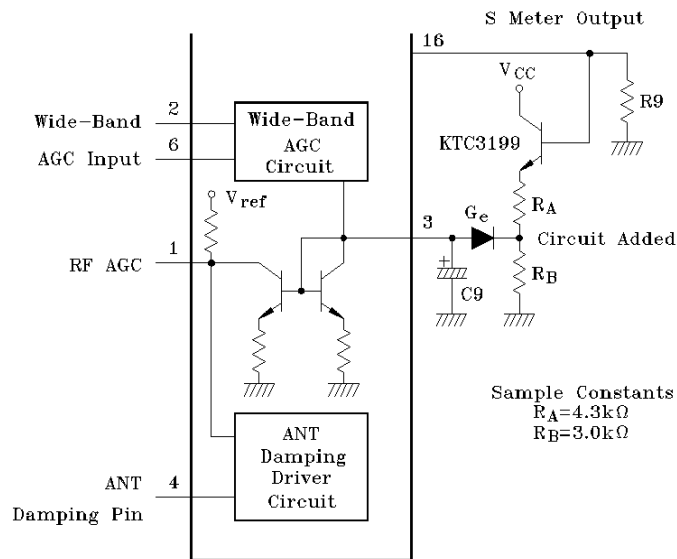

## 10. Transient response of S meter output at search, stop mode

The circuit configuration shown below is available to stabilize the transient response of the S meter output at the search, stop mode.

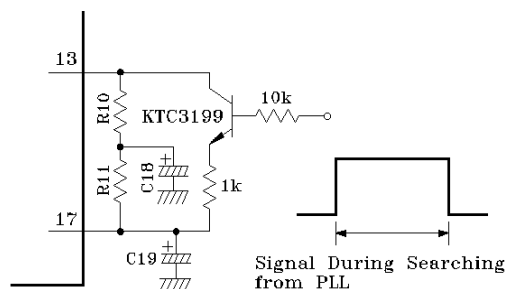

# KIA6035P

11. When using LW(approximately 50°C or greater), additionally connect a resistor of 27kΩ across pins 18 and 19 against increase in local oscillation level. When using MW, no additional resistor is required.
12. Improvement in image frequency interference  
change the RF double-tuning coil as follows, and the image frequency interference becomes 63 dB at f=1400kHz (Q of the tuning circuit must not be decreased with tuning resistor 100kΩ)

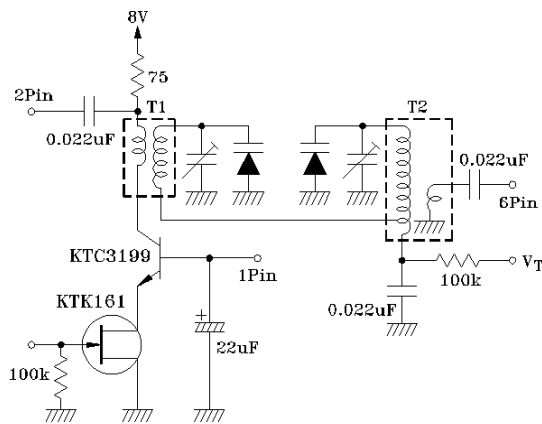

13. Cross Modulation Characteristic Testing Method.

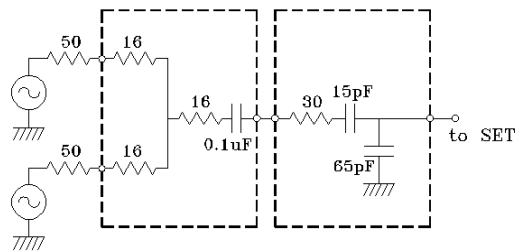

2-signal pad DUMMY ANT

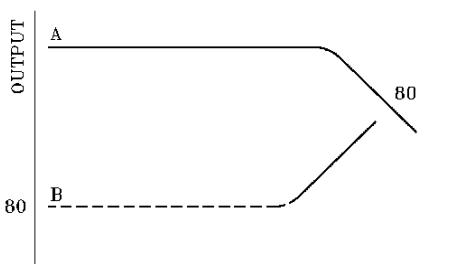

Solid line - Interference.  
Dotted line ..... No Interference.

A : Desired signal 80dBμ 400Hz 30% mod.  
The strength of an undesired signal(non-mod) causes the desired signal to be suppressed.

B : Desired signal 80dBμ non-mod. The strength of an undesired signal (400Hz 80% mod) causes interference to occur.

# KIA6035P

## COIL DATA(BOTTOM VIEW)

### 1. RF Double Tuning Coil

Primary ( $T_1$ )

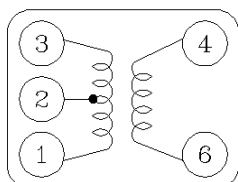

ITEM	L( $\mu$ H)	Turns		
		1-2	2-3	6-4
PIN NO.	1-3	1-2	2-3	6-4
Value	224	2	82	37

YT-30020(Mitsumi)

Secondary ( $T_2$ )

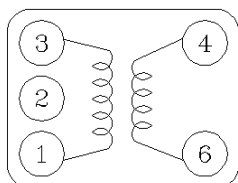

ITEM	L( $\mu$ H)	Turns		
		1-2	2-3	6-4
PIN NO.	1-3	1-2	2-3	6-4
Value	224	2	82	15

YT-30018(Mitsumi)

### 2. IFT(1) Coil ( $T_3$ )

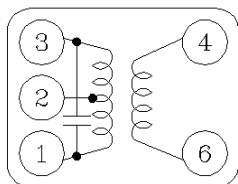

ITEM	$C_o$ (pf)	f(kHz)	Qu(%)	Turns		
				1-2	2-3	6-4
PIN NO.	1-3	-	1-3	1-2	2-3	6-4
Value	180	450	115	69	77	14

CFMA-027(Toko)

High Selectivity Type

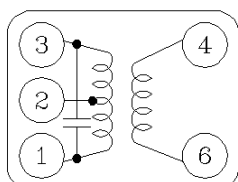

ITEM	$C_o$ (pf)	f(kHz)	Qu(%)	Turns		
				1-2	2-3	6-4
PIN NO.	1-3	-	1-3	1-2	2-3	6-4
Value	180	450	45	49	103	27

YT-30042(Mitsumi)

### 3. IFT(2) Coil( $T_4$ )

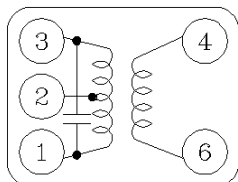

ITEM	$C_o$ (pf)	f(kHz)	Qu(%)	Turns		
				1-2	2-3	6-4
PIN NO.	1-3	-	1-3	1-2	2-3	6-4
Value	180	455	110	115	37	6

YT-30007(Mitsumi)

### 4. OSC Coil( $T_5$ )

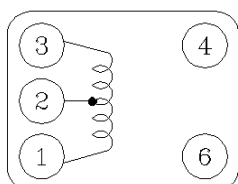

ITEM	L( $\mu$ H)	Turns	
		1-2	2-3
PIN NO.	1-3	1-2	2-3
Value	118	29	29

YT-30008(Mitsumi)

# KIA6035P

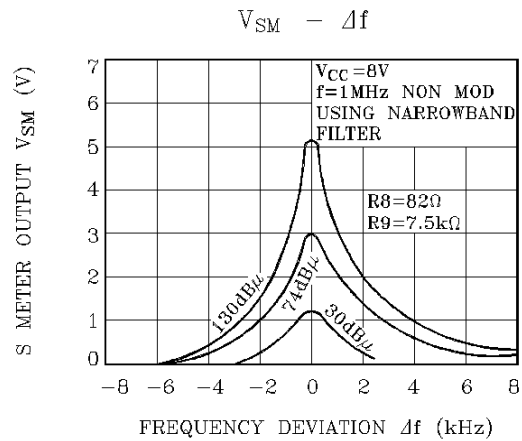
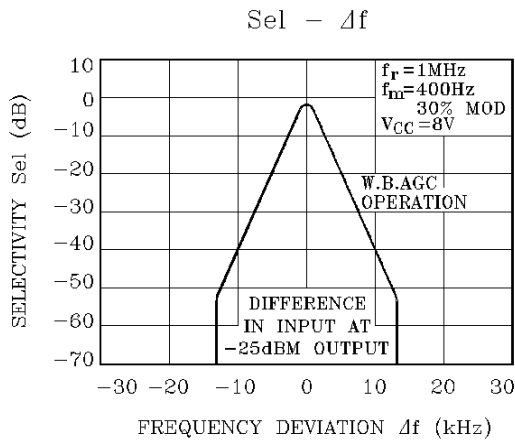
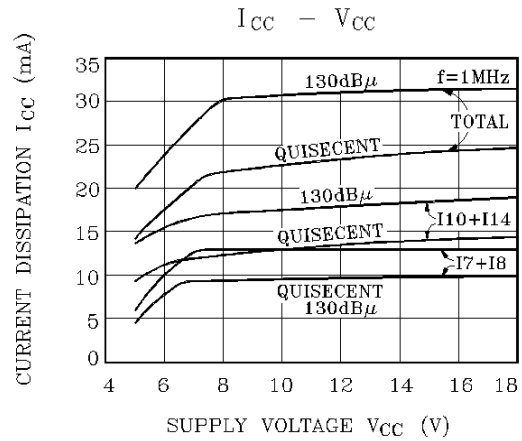
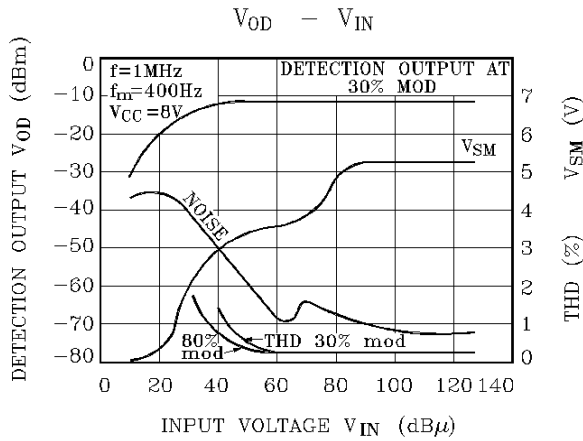

## CROSS MODULATION CHARACTERISTIC

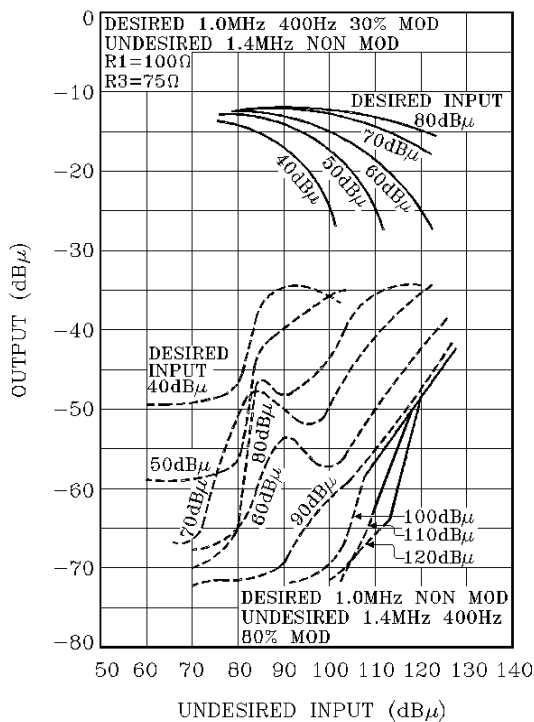

## CROSS MODULATION CHARACTERISTIC

