

**KEC**

KOREA ELECTRONICS CO.,LTD.

**SEMICONDUCTOR  
TECHNICAL DATA**

**KIA6058F**

BIPOLAR LINEAR INTEGRATED CIRCUIT

FM FRONT-END

The KIA6058F is designed for a FM front-end application, which is suitable to a portable radio or a radio cassette.

Comparing with conventional types, supply voltage dependence, overload characteristics and spurious radiation characteristics are improved.

FEATURES

- Wide supply voltage range :  $V_{CC}=1.6\sim 6.0V$ .
- Excellent supply voltage dependence of local oscillator : Oscillation stop  $V_{CC}=0.9V$  (Typ.).
- Improved inter-modulation characteristics by double balanced type mixer circuit.
- Low spurious radiation.
- Built-in clamping diode for the local oscillator output.

MAXIMUM RATINGS ( $T_a=25^{\circ}C$ )

CHARACTERISTIC	SYMBOL	RATING	UNIT
Supply Voltage	$V_{CC}$	6	V
Power Dissipation (Note)	$P_D$	240	mW
Operating Temperature	$T_{opr}$	-25~75	$^{\circ}C$
Storage Temperature	$T_{stg}$	-55~150	$^{\circ}C$

Note : Derated above  $T_a=25^{\circ}C$  in the proportion  $2mW/^{\circ}C$  for KIA6058F

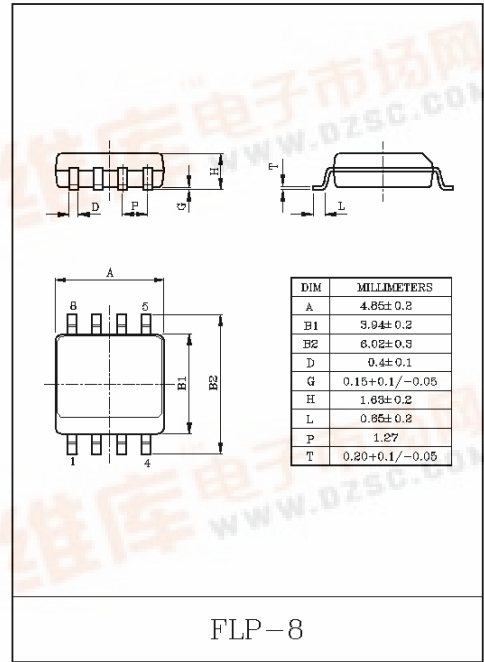

# KIA6058F

## ELECTRICAL CHARACTERISTICS

( $V_{CC}=3V$ ,  $f=98MHz$ ,  $f_m=1kHz$ ,  $\Delta f=22.5kHz$  dev,  $T_a=25^\circ C$ )

CHARACTERISTIC		SYMBOL	TEST CIRCUIT	TEST CONDITION	MIN.	TYP.	MAX.	UNIT
Supply Current		$I_{CC}$	2	$V_{IN}=0$	-	5.2	8.0	mA
-3dB Limiting Sensitivity		$V_{IN(lim.)}$	2		-	3.0	7.0	dB $\mu$
Quiescent Sensitivity		$Q_S$	2		-	11.0	-	dB $\mu$
Conversion Gain		$G_C$	-		-	31	-	dB
Local OSC Voltage		$V_{OSC}$	1	$f_{OSC}=60MHz$	70	110	180	mV $_{rms}$
Pin ① Impedance	Parallel Input Resistance	$r_{ip1}$	3	$f=98MHz$	-	57	-	$\Omega$
Pin ③ Impedance	Parallel Output Resistance	$r_{op3}$	3		-	25	-	k $\Omega$
	Parallel Output Capacitance	$c_{op3}$			-	2.0	-	pF
Pin ④ Impedance	Parallel Input Resistance	$r_{ip4}$	3		-	2.7	-	k $\Omega$
	Parallel Input Capacitance	$c_{ip4}$			-	3.3	-	pF
Pin ⑥ Impedance	Parallel Output Resistance	$r_{op6}$	3		$f=10.7MHz$	-	100	-
	Parallel Output Capacitance	$c_{op6}$		-		4.8	-	pF
Local OSC Stop Voltage		$V_{stop}$	1		-	0.9	1.3	V

# KIA6058F

## BLOCK DIAGRAM

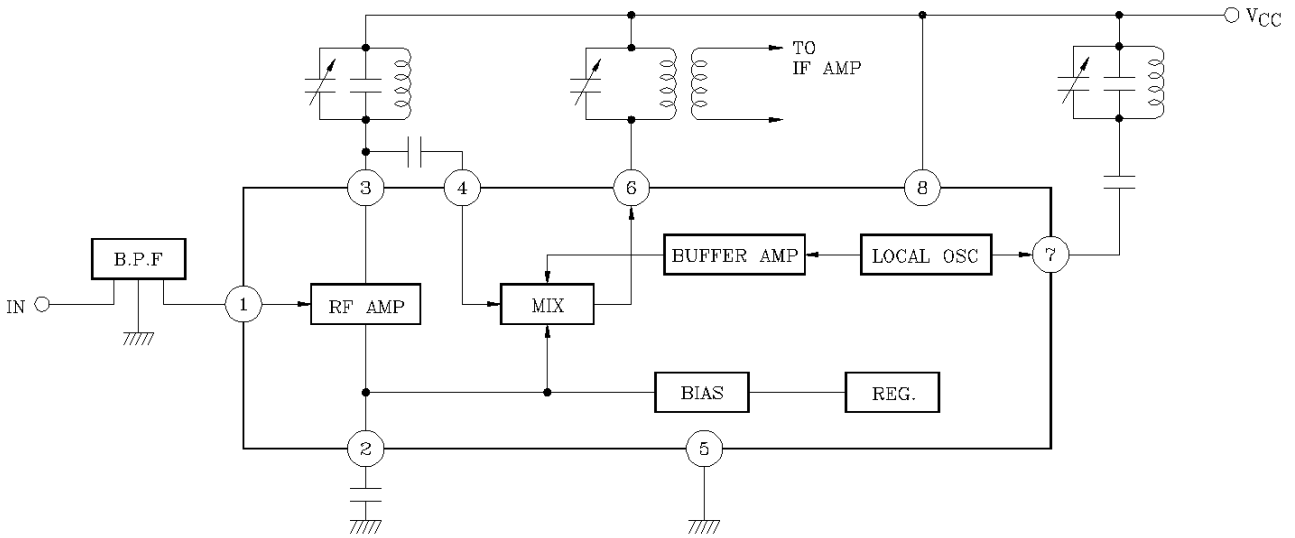

## TEST CIRCUIT 1

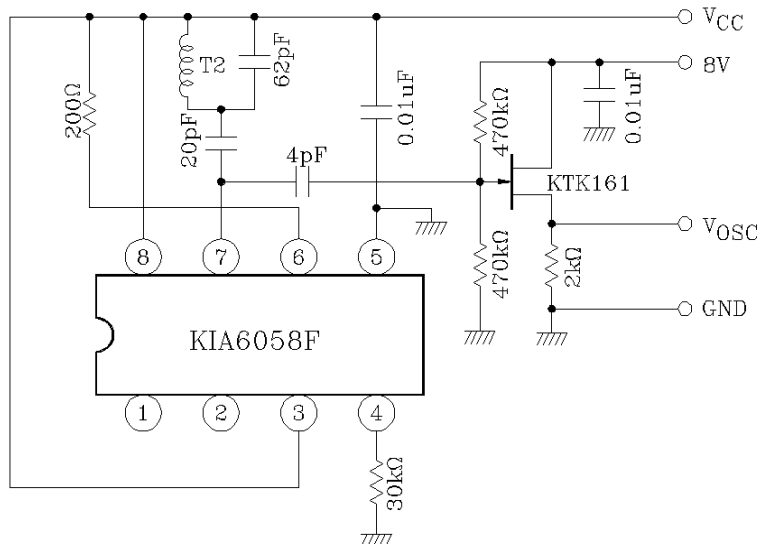

# KIA6058F

TEST CIRCUIT 2

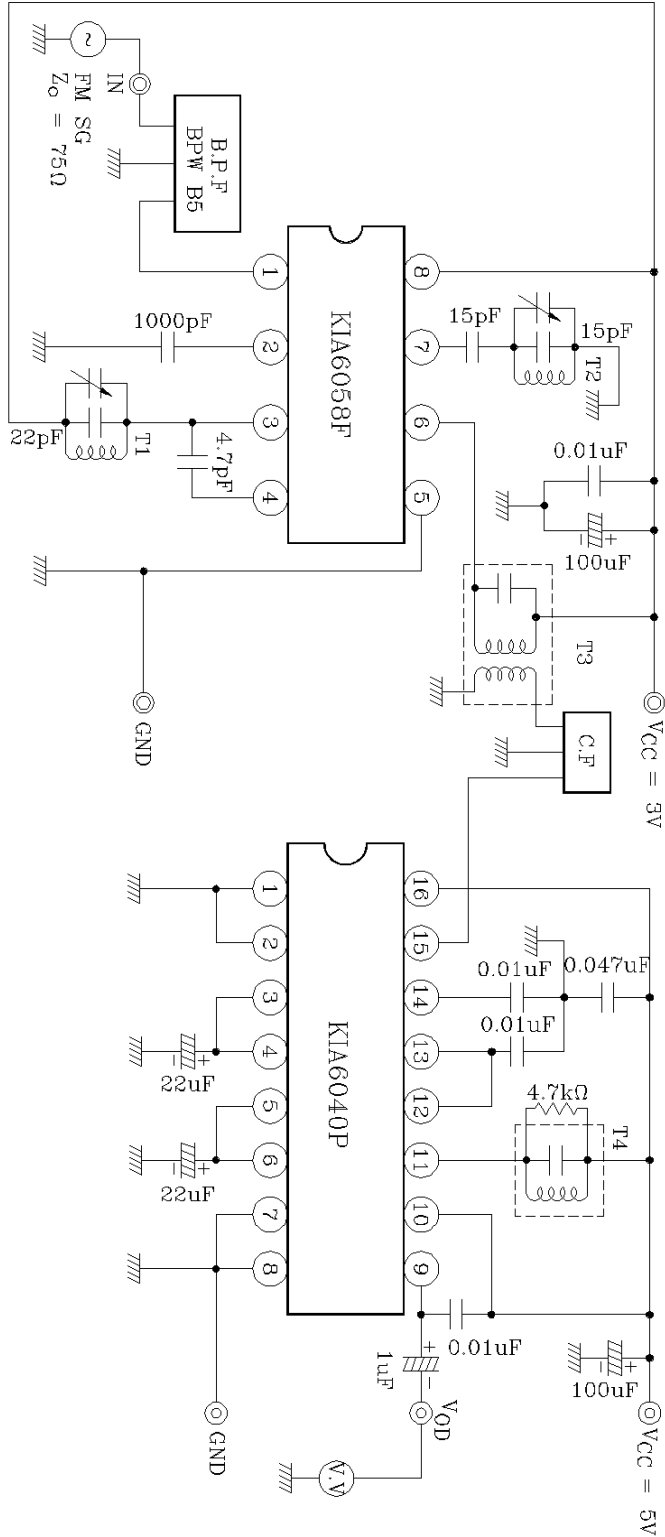

TEST CIRCUIT 2

# KIA6058F

## TEST CIRCUIT 3

### INPUT, OUTPUT IMPEDANCE

(1)  $r_{ip1}$

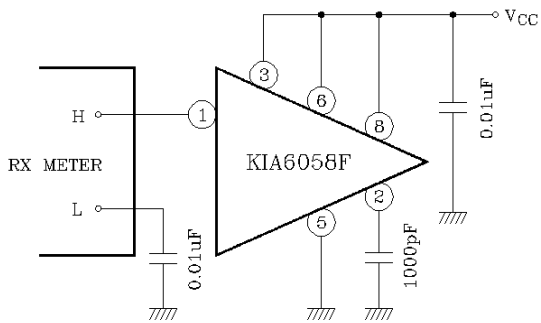

(2)  $r_{op3}$ ,  $c_{op3}$

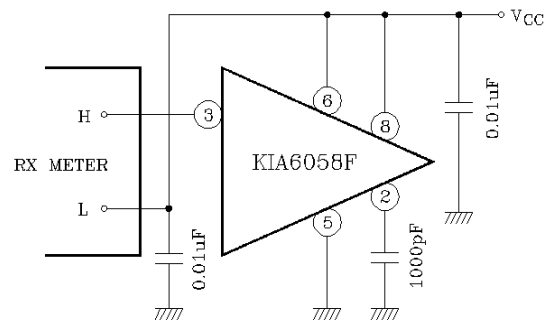

(3)  $r_{ip4}$ ,  $c_{ip4}$

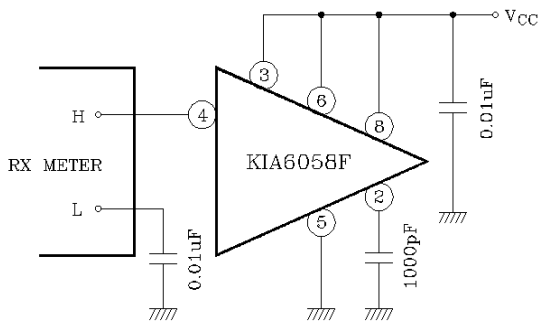

(4)  $r_{op6}$ ,  $c_{op6}$

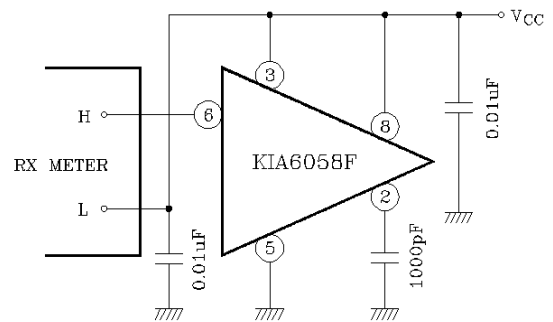

# KIA6058F

TEST CIRCUIT COIL DATA (Japan Band for 76.0MHz to 108.0MHz)

COIL	$f_0$	$Q_0$	TURNS	CAPACITANCE	
T1 RF COIL	100MHz	100	0.7mm $\phi$ $2\frac{1}{4}$ T Center Tap (Japan Band)	15pF (External)	
T2 OSC COIL	100MHz	100	0.7mm $\phi$ $2\frac{1}{2}$ T (Japan Band)	15pF (External)	
T3 IFT	10.7MHz	115	① - ③ 14T ④ - ⑥ 1T Wire 0.12mm $\phi$ UEW Ⓚ : KSFI604 Ⓢ : 5764 or Equivalent	75pF	
T4 QUAD COIL	10.7MHz	150	④ - ⑥ 14T Wire 0.12mm $\phi$ UEW Ⓚ : KSCO902 Ⓢ : 44M-933A or Equivalent	47pF	

Band Pass Filter (B.P.F)

SOSHIN ELECTRIC CO., LTD. BPWB5

Tuning Capacitor

ALPS ELECTRIC CO., LTD. CB41EL933

NOTE : Ⓚ : KWANG SUNG ELECTRONICS CO., LTD. (Tel : 02)716-0034)

Ⓢ : SUMIDA ELECTRIC CO., LTD.