

DUAL PRE-AMPLIFIER

- Dual pre amplifier for car or home stereo use.
- High voltage gain : $G_{VO}=100\text{dB}(\text{Typ.})$ at $f=1\text{kHz}$.
- Excellent channel separation and high ripple rejection.
 - : $\text{CHsep}=65\text{dB}(\text{Typ.})$
($f=10\text{kHz}$, $R_g=2.2\text{k}\Omega$, $V_{out}=0\text{dBm}$)
 - : $\text{R.R.}=50\text{dB}(\text{Typ.})$
- Low noise : $V_{NI}=1.0\mu\text{V}_{\text{rms}}(\text{Typ.})$
at $R_g=2.2\text{k}\Omega$, $B_w=20\text{Hz}\sim 20\text{kHz}$.
- Wide operating supply voltage range.
 - : $V_{CC}=6\sim 16\text{V}$ ($T_a=25^\circ\text{C}$)

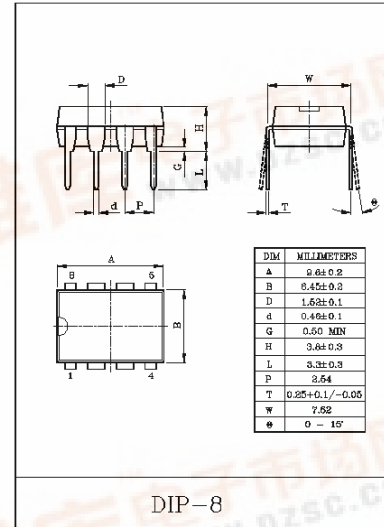

MAXIMUM RATINGS ($T_a=25^\circ\text{C}$)

CHARACTERISTIC	SYMBOL	RATING	UNIT
Supply Voltage	V_{CC}	16	V
Power Dissipation (Note)	P_D	600	mW
		700	
Operating Temperature	T_{opt}	-30~85	$^\circ\text{C}$
Storage temperature	T_{stg}	-55~150	$^\circ\text{C}$

Note: Derated above $T_a=25^\circ\text{C}$ in the proportion of $5.6\text{mW}/^\circ\text{C}^2$ for KIA6225S, and of $4.8\text{mW}/^\circ\text{C}$ for KIA6225P.

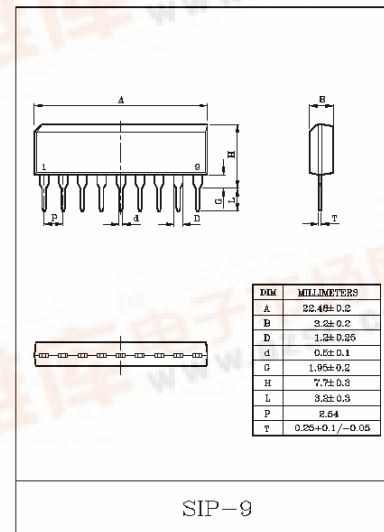

ELECTRICAL CHARACTERISTICS

(Unless otherwise specified, $V_{CC}=6\text{V}$, $f=1\text{kHz}$, $R_g=600\Omega$, $R_L=10\text{k}\Omega$, $T_a=25^\circ\text{C}$)

CHARACTERISTIC	SYMBOL	TEST CIRCUIT	TEST CONDITION	MIN.	TYP.	MAX.	UNIT
Supply Current	I_{CC}	-	$V_{IN}=0$	-	3	6	mA
Voltage Gain	G_{VO}	-	$V_{OUT}=0\text{dBm}$	75	100	-	dB
	G_V	-	$V_{OUT}=0\text{dBm}$	38.5	41.5	44.5	
Maximum Output Voltage	V_{OM}	-	THD=1%	1.0	1.8	-	V_{rms}
Equivalent Input Noise Voltage	V_{NI}	-	$R_g=2.2\text{k}\Omega$, $\text{BPF}=20\text{Hz}\sim 20\text{kHz}$	-	1.0	1.7	μV_{rms}
Input Resistance	R_{IN}	-	-	50	150	-	$\text{k}\Omega$
Channel Separation	CHsep	-	$f=10\text{kHz}$, $V_{OUT}=0\text{dBm}$	-	65	-	dB
Ripple Rejection	R.R	-	$f=100\text{Hz}$, $R_g=2.2\text{k}\Omega$	-	50	-	dB
Total Harmonic Distortion	THD	-	$V_{OUT}=0\text{dBm}$	-	0.04	0.25	%



KIA6225P/S

TEST CIRCUIT

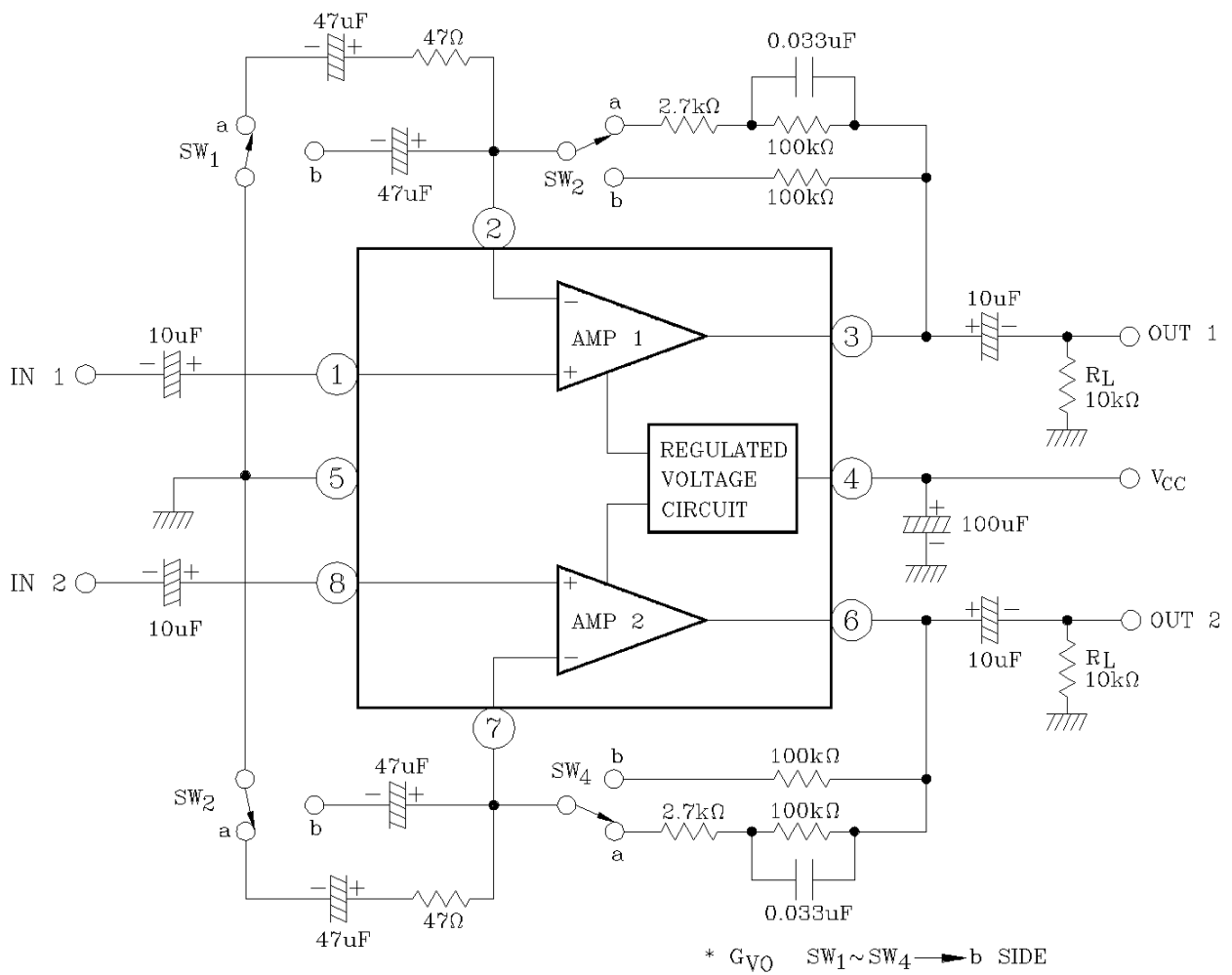

KIA6225P/S

APPLICATION CIRCUIT

NAB EQ

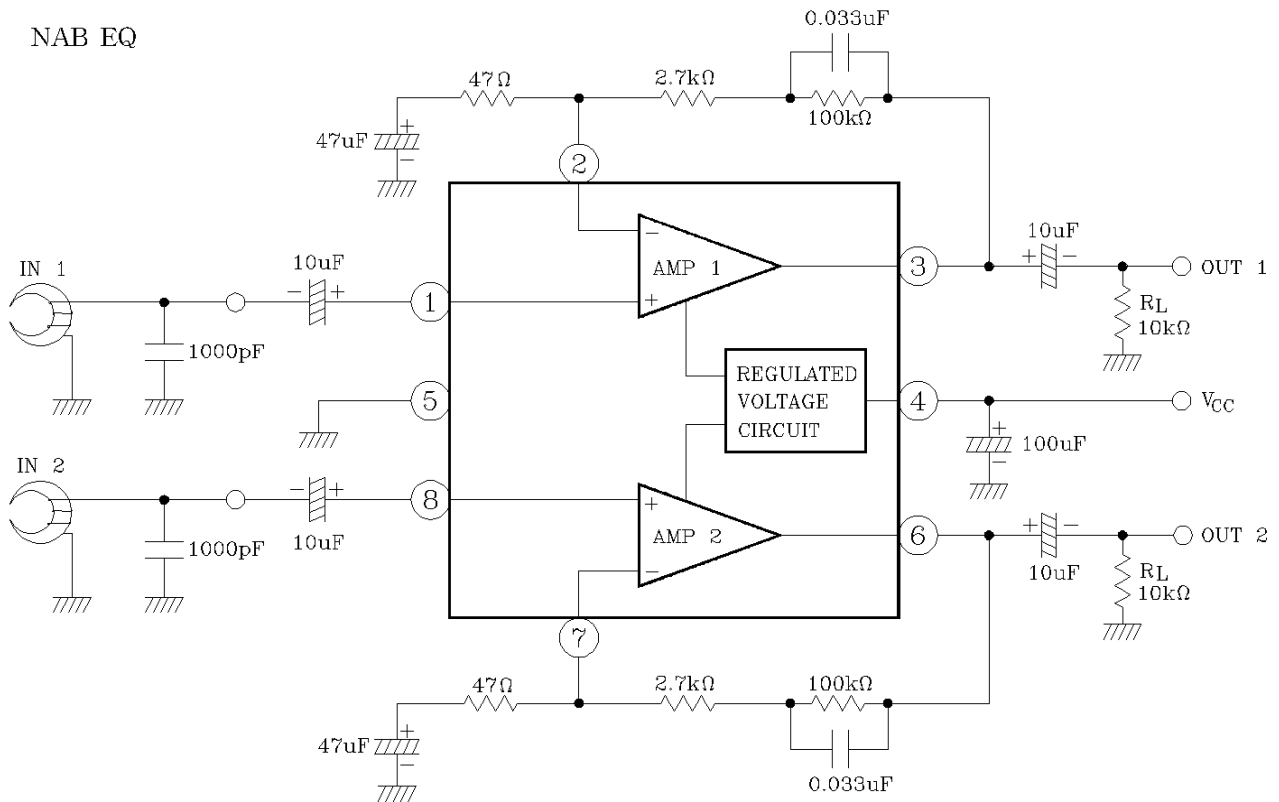

KIA6225P/S

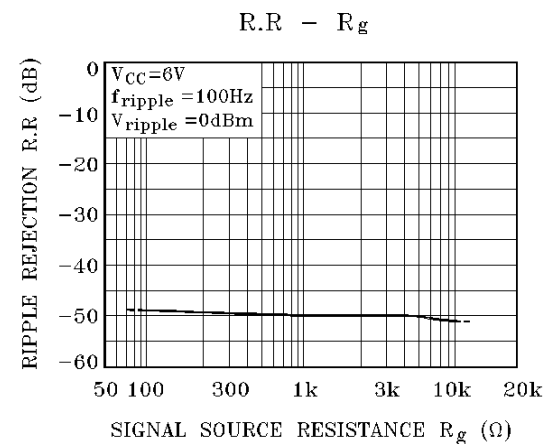
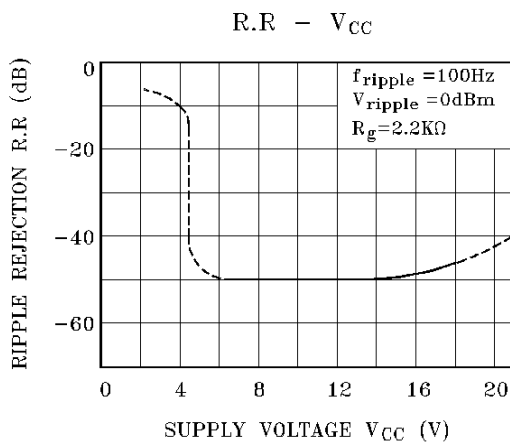
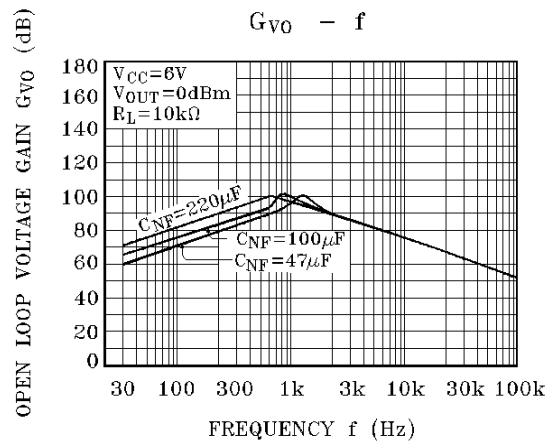
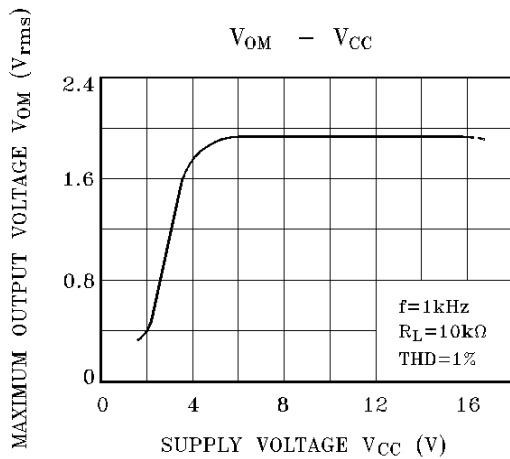
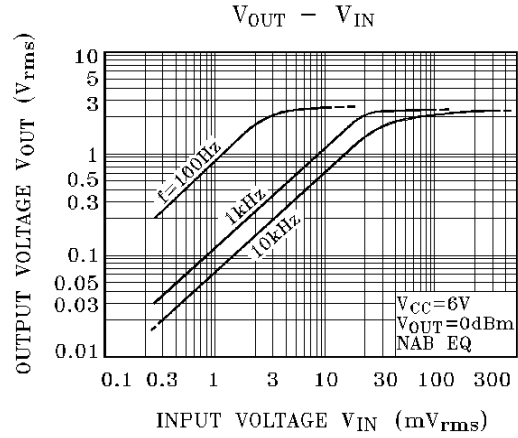
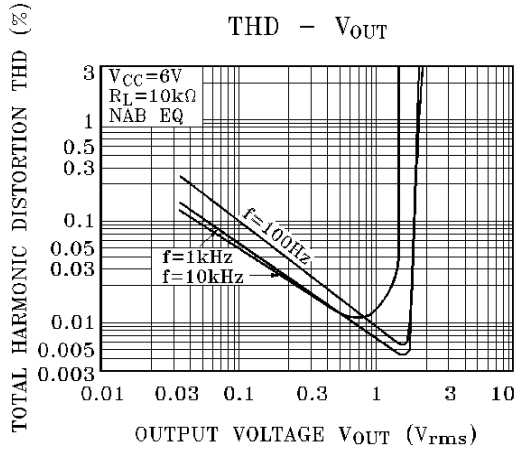

KIA6225P/S

