

Under Development

VOLTAGE DETECTOR

Function of this IC is accurately resetting the system after detecting voltage at the time of switching power on and instantaneous power off in various CPU systems and other logic systems.

FEATURES

- Current Consumption is Low. $I_{CC1}=100\mu A$ Typ. $I_{CCH}=1\mu A$ Typ.
- Resetting Output Minimum Guarantee Voltage is Low 0.8V Typ.
- Hysteresis Voltage is Provided. 50mV Typ.
- Reset Signal Generation Starting Voltages:

KIA7719P/S	1.9V Typ.	KIA7733P/S	3.3V Typ.
KIA7721P/S	2.1V Typ.	KIA7734P/S	3.4V Typ.
KIA7723P/S	2.3V Typ.	KIA7735P/S	3.5V Typ.
KIA7725P/S	2.5V Typ.	KIA7736P/S	3.6V Typ.
KIA7727P/S	2.7V Typ.	KIA7739P/S	3.9V Typ.
KIA7729P/S	2.9V Typ.	KIA7742P/S	4.2V Typ.
KIA7731P/S	3.1V Typ.	KIA7745P/S	4.5V Typ.
KIA7732P/S	3.2V Typ.		
- Taping Type is also Available.

APPLICATIONS

- (1) As Control Circuit of Battery-Backed Memory.
- (2) As Measure Against Erroneous Operations at Power ON-OFF.
- (3) As Measure Against System Runaway at Instantaneous Break of Power Supply etc.
- (4) As Resetting Function for the CPU-Mounted Equipment, such as Personal Computers, Printers, VTRs and so forth.

EQUIVALENT CIRCUIT

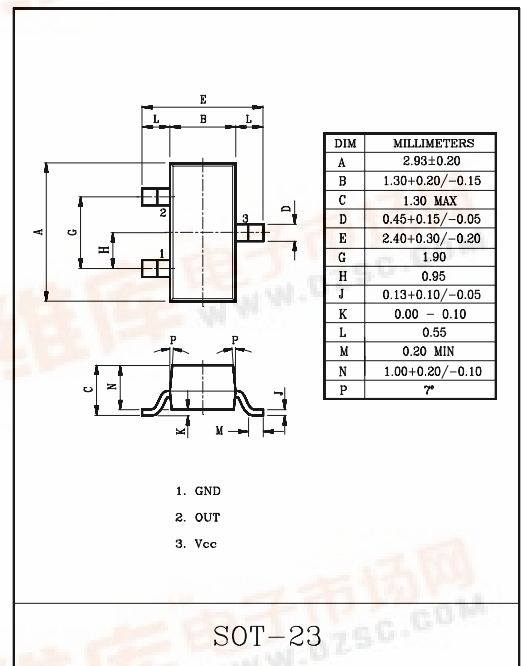
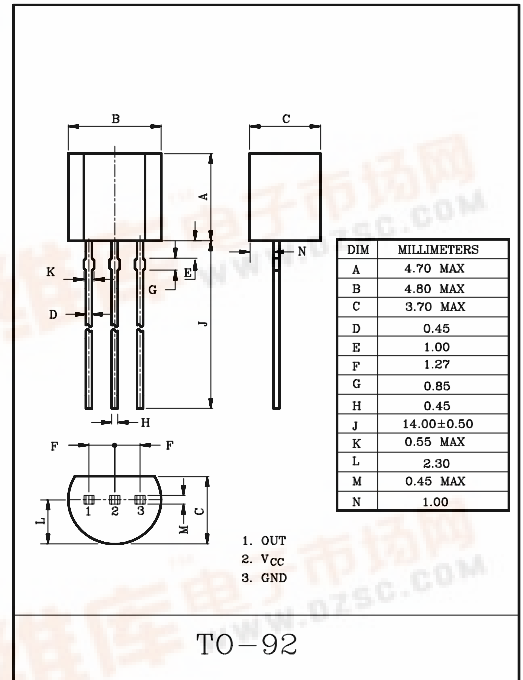
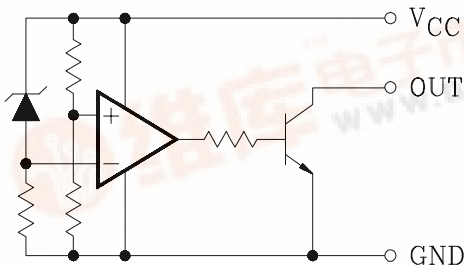

MAXIMUM RATINGS (Ta=25°C)

CHARACTERISTIC	SYMBOL	RATING	UNIT
Supply Voltage	V_{CC}	-0.3 ~ +10	V
Power Dissipation (Package Limitation)	KIA7719P~45P	400	mW
	KIA7719S~45S	350	
Operating Temperature	T_{opr}	-30 ~ +75	°C
Storage Temperature	T_{stg}	-55 ~ +150	°C

MARKING

Type No.	Marking	Type No.	Marking
KIA7719S	77A	KIA7733S	77J
KIA7721S	77B	KIA7734S	77K
KIA7723S	77C	KIA7735S	77L
KIA7725S	77D	KIA7736S	77M
KIA7727S	77E	KIA7739S	77N
KIA7729S	77F	KIA7742S	77P
KIA7731S	77G	KIA7745S	77R
KIA7732S	77H		

KIA7719P/S ~ KIA7745P/S

Under Development

ELECTRICAL CHARACTERISTICS

CHARACTERISTIC	SYMBOL	TEST CIR.	TEST CONDITION	MIN.	TYP.	MAX.	UNIT	
Detecting Voltage	V _S	1	R _L =470Ω V _{OL} ≤0.4V	KIA7719P/S	1.862	1.9	1.938	V
				KIA7721P/S	2.058	2.1	2.142	
				KIA7723P/S	2.254	2.3	2.346	
				KIA7725P/S	2.450	2.5	2.550	
				KIA7727P/S	2.646	2.7	2.754	
				KIA7729P/S	2.842	2.9	2.958	
				KIA7731P/S	3.038	3.1	3.162	
				KIA7732P/S	3.136	3.2	3.264	
				KIA7733P/S	3.234	3.3	3.366	
				KIA7734P/S	3.332	3.4	3.468	
				KIA7735P/S	3.430	3.5	3.570	
				KIA7736P/S	3.528	3.6	3.672	
				KIA7739P/S	3.822	3.9	3.978	
KIA7742P/S	4.116	4.2	4.284					
KIA7745P/S	4.410	4.5	4.590					
Low-Level Output Voltage	V _{OL}	1	R _L =470Ω	-	-	0.4	V	
Output Leakage Current	I _{OH}	1	V _{CC} =10V	-	-	0.1	μA	
Hysteresis Voltage	ΔV _S	1	R _L =470Ω	30	50	100	mV	
Detecting Voltage Temperature Coefficient	V _S /ΔT	1	R _L =470Ω	-	±0.01	-	%/°C	
Circuit Current at on Time	I _{ccL}	1	V _{CC} =V _{Smin} .-0.05V	-	100	150	μA	
Circuit Current at off Time	I _{ccH}	1	V _{CC} =V _{Smax} +0.1V	-	1.0	2.5	μA	
Threshold Operating Voltage	V _{opr}	1	R _L =4.7kΩ, V _{OL} ≤0.4V	-	0.8	-	V	
"L" Transmission Delay Time	tpHL	2	R _L =4.7kΩ, C _L =100pF	-	10	-	μS	
"H" Transmission Delay Time	tpLH	2	R _L =4.7kΩ, C _L =100pF	-	15	-	μS	
Output Current at on Time I	I _{oL I}	1	V _{CC} =V _{Smin} .-0.05V T _C =25°C	15	-	-	mA	
Output Current at on Time II	I _{oL II}	1	V _{CC} =V _{Smin} .-0.05V T _C =-30~+75°C	7	-	-	mA	

KIA7719P/S ~ KIA7745P/S

I Inder Development

TEST CIRCUIT 1.

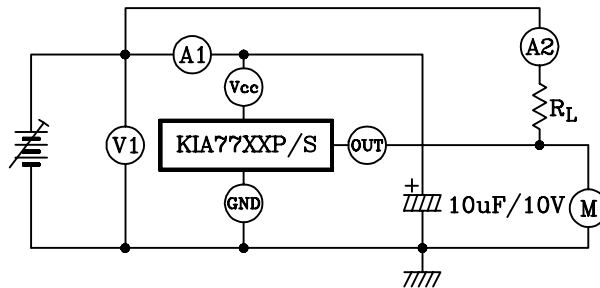

TEST CIRCUIT 2.

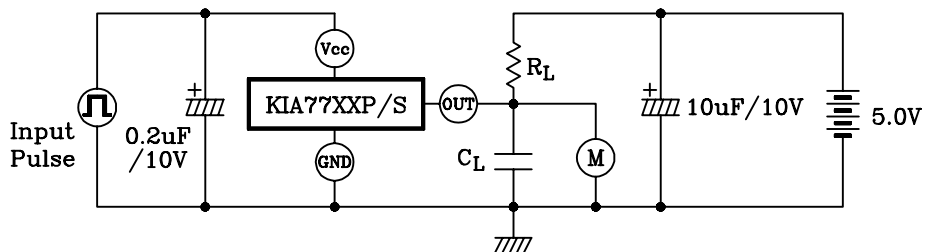

APPLICATION CIRCUIT

(1) BATTERY LOW INDICATOR

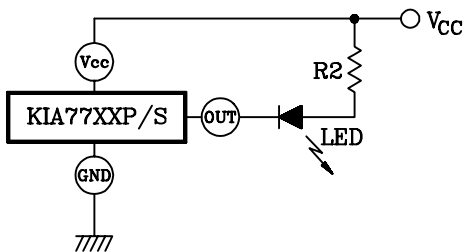

(2) CPU RESETTING

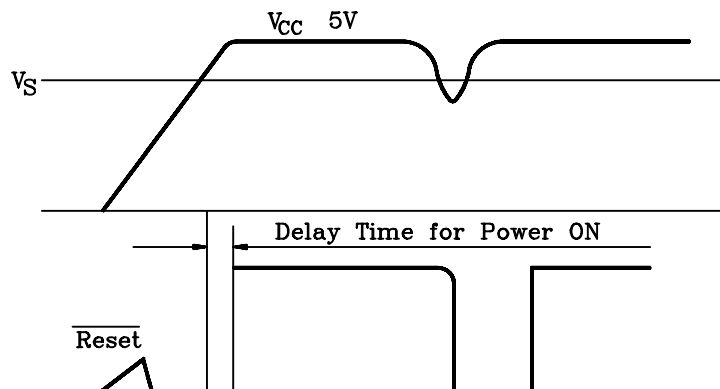
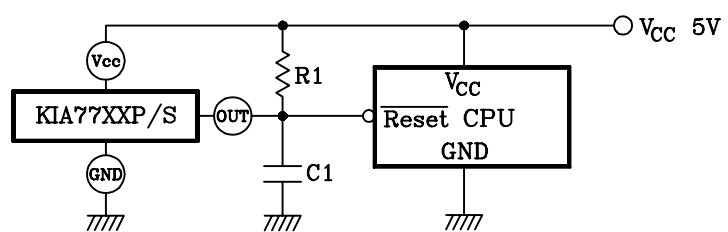

(NOTE)

- (1) Connecting of LED and R2 obtains a voltage drop indicator.
- (2) Connecting of C1 and selection of time constant with C1 and R1 set the power on delay time.

KIA7719P/S ~ KIA7745P/S

Under Development

PRECAUTION FOR USE

SOLDERING

Flat Package (SOT-23 Package)

Elements mounting styles of electronic devices are gaining in further diversification over recent years, and needs for components are all the more expanding in varieties. Especially, surface mounting is steadily penetrating into industrial segments as a world-wide popular technical trend. Although exposure to high temperature is inevitable during soldering we recommend limiting the soldering temperature to low levels as shown in figure for the sake of retaining inherent excellent reliability.

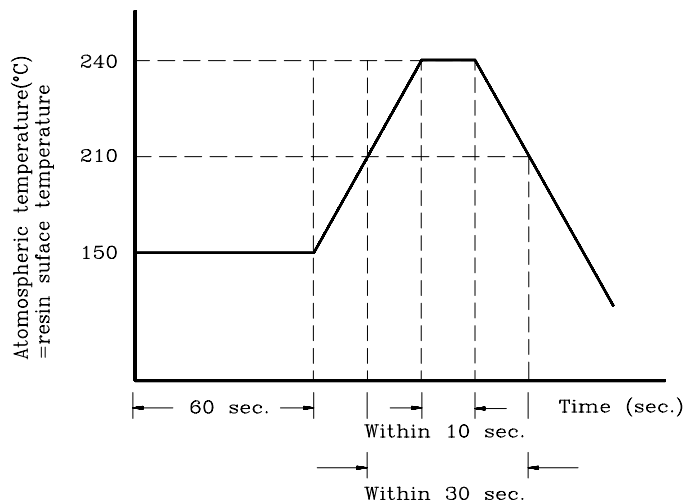

Fig 6

(a) When employing solder reflow method

- ① Atmospheric temperature around resin surfaces must be less than 240°C, not exceeding the time length of 10 sec.
- ② Recommend temperature profile
- ③ Precautions on heating method

When resin is kept exposed to high temperature for a long time, device reliability may be marred. Therefore, it is essential to complete soldering in the shortest time possible to prevent temperature of resin from rising.

(b) When employing halogen lamps or infrared-ray heaters

When halogen lamps or infrared-ray heaters are used, avoid direct irradiation onto resin surfaces; such devices cause extensive localized temperature rise.

※ Please keep a reflow solder operating when SOT-23 package's soldering.