

**KEC**

KOREA ELECTRONICS CO.,LTD.

**SEMICONDUCTOR  
TECHNICAL DATA**

**KIA78L05F ~  
KIA78L24F**

BIPOLAR LINEAR INTEGRATED CIRCUIT

THREE TERMINAL POSITIVE VOLTAGE REGULATORS  
5V, 6V, 7V, 8V, 9V, 10V, 12V, 15V, 18V, 20V, 24V.

FEATURES

- Best Suited to Power Supply for TTL, C<sup>2</sup>-MOS.
- No External Part Needed.
- Built-in Thermal Protective Circuit.
- Max. Output Current 150mA (T<sub>j</sub>=25°C).
- Packaged in Power Mini.

MAXIMUM RATINGS (T<sub>a</sub>=25°C)

CHARACTERISTIC	SYMBOL	RATING	UNIT
Input Voltage	V <sub>IN</sub>	35	V
		(5V~15V)	
		40	
		(18V~24V)	
Power Dissipation	P <sub>D</sub>	500	mW
Operating Junction Temperature	T <sub>j</sub>	-30~150	°C
Operating Temperature	T <sub>opr</sub>	-30~75	°C
Storage Temperature	T <sub>stg</sub>	-55~150	°C

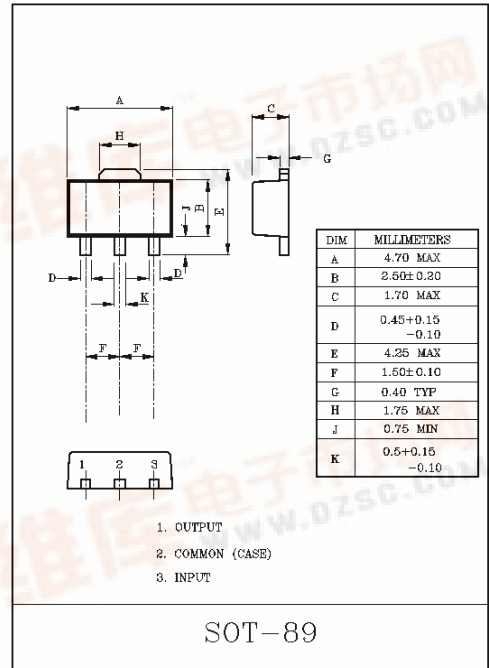

EQUIVALENT CIRCUIT

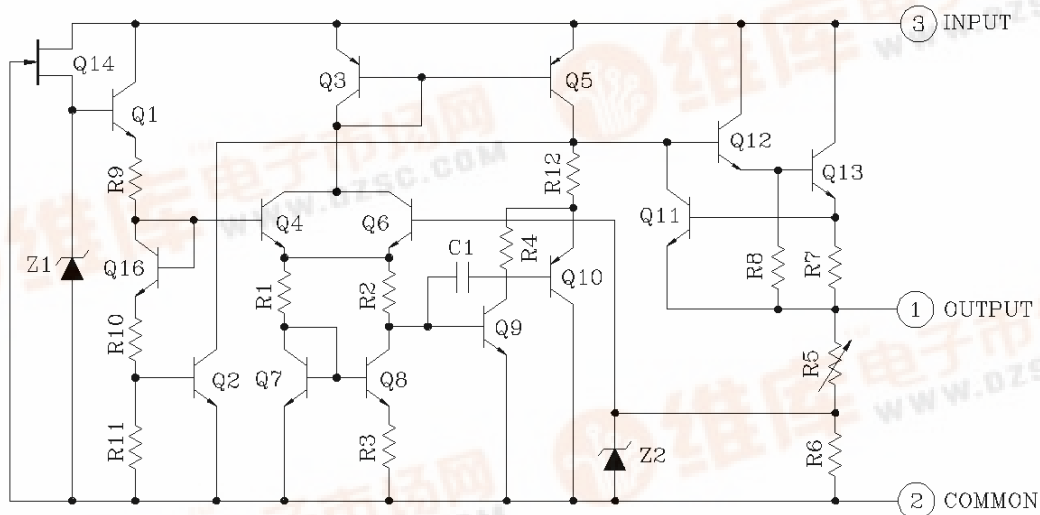

MARKING

Type No.	Marking	Type No.	Marking	Type No.	Marking
KIA78L05F	8A	KIA78L09F	8E	KIA78L15F	8I
KIA78L06F	8B	KIA78L10F	8F	KIA78L18F	8J
KIA78L07F	8C	KIA78L12F	8G	KIA78L20F	8K
KIA78L08F	8D	KIA78L13F	8H	KIA78L24F	8L



# KIA78L05F ~ KIA78L24F

## ELECTRICAL CHARACTERISTICS

KIA78L05F

(Unless otherwise specified,  $V_{IN}=10V$ ,  $I_{OUT}=40mA$ ,  $C_{IN}=0.33\mu F$ ,  $C_{OUT}=0.1\mu F$ ,  $0^{\circ}C \leq T_j \leq 125^{\circ}C$ )

CHARACTERISTIC	SYMBOL	TEST CIRCUIT	TEST CONDITION	MIN.	TYP.	MAX.	UNIT	
Output Voltage	$V_{OUT}$	1	$T_j=25^{\circ}C$	4.75	5.0	5.25	V	
Input Regulation	Reg line	1	$T_j=25^{\circ}C$	$7.0V \leq V_{IN} \leq 20V$	-	55	150	mV
				$8.0V \leq V_{IN} \leq 20V$	-	45	100	
Load Regulation	Reg load	1	$T_j=25^{\circ}C$	$1.0mA \leq I_{OUT} \leq 100mA$	-	11	60	mV
				$1.0mA \leq I_{OUT} \leq 40mA$	-	5.0	30	
Output Voltage	$V_{OUT}$	1	$7.0V \leq V_{IN} \leq 20V$ $1.0mA \leq I_{OUT} \leq 40mA$	4.65	-	5.3	V	
			$V_{IN}=10V$ , $1.0mA \leq I_{OUT} \leq 70mA$	4.65	-	5.3		
Quiescent Current	$I_B$	1	$T_j=25^{\circ}C$	-	3.1	6.0	mA	
			$T_j=125^{\circ}C$	-	-	5.5		
Quiescent Current Change	$\Delta I_B$	1	$8.0V \leq V_{IN} \leq 20V$	-	-	1.5	mA	
			$1.0mA \leq I_{OUT} \leq 40mA$	-	-	0.1		
Output Noise Voltage	$V_{NO}$	1	$T_a=25^{\circ}C$ , $10Hz \leq f \leq 100kHz$	-	40	-	$\mu V_{rms}$	
Long Term Stability	$\Delta V_{OUT}/\Delta t$	1		-	12	-	mV/ 1.0kHrs	
Ripple Rejection Ratio	RR	2	$f=120Hz$ , $8.0V \leq V_{IN} \leq 18V$ , $T_j=25^{\circ}C$	41	49	-	dB	
Dropout Voltage	$ V_{IN} - V_{OUT} $	1	$T_j=25^{\circ}C$	-	1.7	-	V	
Average Temperature Coefficient of Output Voltage	$TC_{VO}$	1	$I_{OUT}=5mA$	-	-0.6	-	mV/ $^{\circ}C$	

# KIA78L05F ~ KIA78L24F

## ELECTRICAL CHARACTERISTICS

KIA78L06F

(Unless otherwise specified,  $V_{IN}=11V$ ,  $I_{OUT}=40mA$ ,  $C_{IN}=0.33\mu F$ ,  $C_{OUT}=0.1\mu F$ ,  $0^{\circ}C \leq T_j \leq 125^{\circ}C$ )

CHARACTERISTIC	SYMBOL	TEST CIRCUIT	TEST CONDITION	MIN.	TYP.	MAX.	UNIT	
Output Voltage	$V_{OUT}$	1	$T_j=25^{\circ}C$	5.7	6.0	6.3	V	
Input Regulation	Reg line	1	$T_j=25^{\circ}C$	$8.1V \leq V_{IN} \leq 21V$	-	50	150	mV
				$9.0V \leq V_{IN} \leq 21V$	-	45	110	
Load Regulation	Reg load	1	$T_j=25^{\circ}C$	$1.0mA \leq I_{OUT} \leq 100mA$	-	12	70	mV
				$1.0mA \leq I_{OUT} \leq 40mA$	-	5.5	35	
Output Voltage	$V_{OUT}$	1	$8.1V \leq V_{IN} \leq 21V$ $1.0mA \leq I_{OUT} \leq 40mA$	5.58	-	6.42	V	
			$V_{IN}=11V$ , $1.0mA \leq I_{OUT} \leq 70mA$	5.58	-	6.42		
Quiescent Current	$I_B$	1	$T_j=25^{\circ}C$	-	3.1	6.0	mA	
			$T_j=125^{\circ}C$	-	-	5.5		
Quiescent Current Change	$\Delta I_B$	1	$9.0V \leq V_{IN} \leq 20V$	-	-	1.5	mA	
			$1.0mA \leq I_{OUT} \leq 40mA$	-	-	0.1		
Output Noise Voltage	$V_{NO}$	1	$T_a=25^{\circ}C$ , $10Hz \leq f \leq 100kHz$	-	40	-	$\mu V_{rms}$	
Long Term Stability	$\Delta V_{OUT}/\Delta t$	1		-	14	-	mV/ 1.0kHrs	
Ripple Rejection Ratio	RR	2	$f=120Hz$ , $9.0V \leq V_{IN} \leq 19V$ , $T_j=25^{\circ}C$	39	47	-	dB	
Dropout Voltage	$ V_{IN} - V_{OUT} $	1	$T_j=25^{\circ}C$	-	1.7	-	V	
Average Temperature Coefficient of Output Voltage	$TC_{VO}$	1	$I_{OUT}=5mA$	-	-0.7	-	mV/ $^{\circ}C$	

# KIA78L05F ~ KIA78L24F

## ELECTRICAL CHARACTERISTICS

KIA78L07F

(Unless otherwise specified,  $V_{IN}=12V$ ,  $I_{OUT}=40mA$ ,  $C_{IN}=0.33\mu F$ ,  $C_{OUT}=0.1\mu F$ ,  $0^{\circ}C \leq T_j \leq 125^{\circ}C$ )

CHARACTERISTIC	SYMBOL	TEST CIRCUIT	TEST CONDITION	MIN.	TYP.	MAX.	UNIT	
Output Voltage	$V_{OUT}$	1	$T_j=25^{\circ}C$	6.72	7.0	7.28	V	
Input Regulation	Reg line	1	$T_j=25^{\circ}C$	$9.2V \leq V_{IN} \leq 22V$	-	50	160	mV
				$10V \leq V_{IN} \leq 22V$	-	45	115	
Load Regulation	Reg load	1	$T_j=25^{\circ}C$	$1.0mA \leq I_{OUT} \leq 100mA$	-	13	75	mV
				$1.0mA \leq I_{OUT} \leq 40mA$	-	6.0	40	
Output Voltage	$V_{OUT}$	1	$9.2V \leq V_{IN} \leq 22V$ $1.0mA \leq I_{OUT} \leq 40mA$	6.65	-	7.35	V	
			$V_{IN}=12V$ , $1.0mA \leq I_{OUT} \leq 70mA$	6.65	-	7.35		
Quiescent Current	$I_B$	1	$T_j=25^{\circ}C$	-	3.1	6.5	mA	
			$T_j=125^{\circ}C$	-	-	6.0		
Quiescent Current Change	$\Delta I_B$	1	$10V \leq V_{IN} \leq 22V$	-	-	1.5	mA	
			$1.0mA \leq I_{OUT} \leq 40mA$	-	-	0.1		
Output Noise Voltage	$V_{NO}$	1	$T_a=25^{\circ}C$ , $10Hz \leq f \leq 100kHz$	-	50	-	$\mu V_{rms}$	
Long Term Stability	$\Delta V_{OUT}/\Delta t$	1		-	17	-	mV/ 1.0kHrs	
Ripple Rejection Ratio	RR	2	$f=120Hz$ , $10V \leq V_{IN} \leq 20V$ , $T_j=25^{\circ}C$	37	46	-	dB	
Dropout Voltage	$ V_{IN}-V_{OUT} $	1	$T_j=25^{\circ}C$	-	1.7	-	V	
Average Temperature Coefficient of Output Voltage	$TC_{VO}$	1	$I_{OUT}=5mA$	-	-0.75	-	mV/ $^{\circ}C$	

# KIA78L05F ~ KIA78L24F

## ELECTRICAL CHARACTERISTICS

KIA78L08F

(Unless otherwise specified,  $V_{IN}=14V$ ,  $I_{OUT}=40mA$ ,  $C_{IN}=0.33\mu F$ ,  $C_{OUT}=0.1\mu F$ ,  $0^{\circ}C \leq T_j \leq 125^{\circ}C$ )

CHARACTERISTIC	SYMBOL	TEST CIRCUIT	TEST CONDITION	MIN.	TYP.	MAX.	UNIT	
Output Voltage	$V_{OUT}$	1	$T_j=25^{\circ}C$	7.6	8.0	8.4	V	
Input Regulation	Reg line	1	$T_j=25^{\circ}C$	$10.5V \leq V_{IN} \leq 23V$	-	20	175	mV
				$11V \leq V_{IN} \leq 23V$	-	12	125	
Load Regulation	Reg load	1	$T_j=25^{\circ}C$	$1.0mA \leq I_{OUT} \leq 100mA$	-	15	80	mV
				$1.0mA \leq I_{OUT} \leq 40mA$	-	7.0	40	
Output Voltage	$V_{OUT}$	1	$10.5V \leq V_{IN} \leq 23V$ $1.0mA \leq I_{OUT} \leq 40mA$	7.44	-	8.56	V	
			$V_{IN}=14V$ , $1.0mA \leq I_{OUT} \leq 70mA$	7.44	-	8.56		
Quiescent Current	$I_B$	1	$T_j=25^{\circ}C$	-	3.1	6.5	mA	
			$T_j=125^{\circ}C$	-	-	6.0		
Quiescent Current Change	$\Delta I_B$	1	$11V \leq V_{IN} \leq 23V$	-	-	1.5	mA	
			$1.0mA \leq I_{OUT} \leq 40mA$	-	-	0.1		
Output Noise Voltage	$V_{NO}$	1	$T_a=25^{\circ}C$ , $10Hz \leq f \leq 100kHz$	-	60	-	$\mu V_{rms}$	
Long Term Stability	$\Delta V_{OUT}/\Delta t$	1		-	20	-	mV/ 1.0kHrs	
Ripple Rejection Ratio	RR	2	$f=120Hz$ , $12V \leq V_{IN} \leq 23V$ , $T_j=25^{\circ}C$	37	45	-	dB	
Dropout Voltage	$ V_{IN} - V_{OUT} $	1	$T_j=25^{\circ}C$	-	1.7	-	V	
Average Temperature Coefficient of Output Voltage	$TC_{VO}$	1	$I_{OUT}=5mA$	-	-0.8	-	mV/ $^{\circ}C$	

# KIA78L05F ~ KIA78L24F

## ELECTRICAL CHARACTERISTICS

KIA78L09F

(Unless otherwise specified,  $V_{IN}=15V$ ,  $I_{OUT}=40mA$ ,  $C_{IN}=0.33\mu F$ ,  $C_{OUT}=0.1\mu F$ ,  $0^{\circ}C \leq T_j \leq 125^{\circ}C$ )

CHARACTERISTIC	SYMBOL	TEST CIRCUIT	TEST CONDITION	MIN.	TYP.	MAX.	UNIT	
Output Voltage	$V_{OUT}$	1	$T_j=25^{\circ}C$	8.55	9.0	9.45	V	
Input Regulation	Reg line	1	$T_j=25^{\circ}C$	$11.4V \leq V_{IN} \leq 24V$	-	80	200	mV
				$12V \leq V_{IN} \leq 24V$	-	20	160	
Load Regulation	Reg load	1	$T_j=25^{\circ}C$	$1.0mA \leq I_{OUT} \leq 100mA$	-	17	90	mV
				$1.0mA \leq I_{OUT} \leq 40mA$	-	8.0	45	
Output Voltage	$V_{OUT}$	1	$11.4V \leq V_{IN} \leq 24V$ , $1.0mA \leq I_{OUT} \leq 40mA$	8.37	-	9.63	V	
			$V_{IN}=15V$ , $1.0mA \leq I_{OUT} \leq 70mA$	8.37	-	9.63		
Quiescent Current	$I_B$	1	$T_j=25^{\circ}C$	-	3.2	6.5	mA	
			$T_j=125^{\circ}C$	-	-	6.0		
Quiescent Current Change	$\Delta I_B$	1	$12V \leq V_{IN} \leq 24V$	-	-	1.5	mA	
			$1.0mA \leq I_{OUT} \leq 40mA$	-	-	0.1		
Output Noise Voltage	$V_{NO}$	1	$T_a=25^{\circ}C$ , $10Hz \leq f \leq 100kHz$	-	65	-	$\mu V_{rms}$	
Long Term Stability	$\Delta V_{OUT}/\Delta t$	1		-	21	-	mV/ 1.0kHrs	
Ripple Rejection Ratio	RR	2	$f=120Hz$ , $12V \leq V_{IN} \leq 24V$ , $T_j=25^{\circ}C$	36	44	-	dB	
Dropout Voltage	$ V_{IN} - V_{OUT} $	1	$T_j=25^{\circ}C$	-	1.7	-	V	
Average Temperature Coefficient of Output Voltage	$TC_{VO}$	1	$I_{OUT}=5mA$	-	-0.85	-	mV/ $^{\circ}C$	

# KIA78L05F ~ KIA78L24F

## ELECTRICAL CHARACTERISTICS

KIA78L10F

(Unless otherwise specified,  $V_{IN}=16V$ ,  $I_{OUT}=40mA$ ,  $C_{IN}=0.33\mu F$ ,  $C_{OUT}=0.1\mu F$ ,  $0^{\circ}C \leq T_j \leq 125^{\circ}C$ )

CHARACTERISTIC	SYMBOL	TEST CIRCUIT	TEST CONDITION	MIN.	TYP.	MAX.	UNIT	
Output Voltage	$V_{OUT}$	1	$T_j=25^{\circ}C$	9.5	10	10.5	V	
Input Regulation	Reg line	1	$T_j=25^{\circ}C$	$12.5V \leq V_{IN} \leq 25V$	-	80	230	mV
				$13V \leq V_{IN} \leq 25V$	-	30	170	
Load Regulation	Reg load	1	$T_j=25^{\circ}C$	$1.0mA \leq I_{OUT} \leq 100mA$	-	18	90	mV
				$1.0mA \leq I_{OUT} \leq 40mA$	-	8.5	45	
Output Voltage	$V_{OUT}$	1	$12.5V \leq V_{IN} \leq 25V$ , $1.0mA \leq I_{OUT} \leq 40mA$	9.3	-	10.7	V	
			$V_{IN}=16V$ , $1.0mA \leq I_{OUT} \leq 70mA$	9.3	-	10.7		
Quiescent Current	$I_B$	1	$T_j=25^{\circ}C$	-	3.2	6.5	mA	
			$T_j=125^{\circ}C$	-	-	6.0		
Quiescent Current Change	$\Delta I_B$	1	$13V \leq V_{IN} \leq 25V$	-	-	1.5	mA	
			$1.0mA \leq I_{OUT} \leq 40mA$	-	-	0.1		
Output Noise Voltage	$V_{NO}$	1	$T_a=25^{\circ}C$ , $10Hz \leq f \leq 100kHz$	-	70	-	$\mu V_{rms}$	
Long Term Stability	$\Delta V_{OUT}/\Delta t$	1		-	22	-	mV/ 1.0kHrs	
Ripple Rejection Ratio	RR	2	$f=120Hz$ , $13V \leq V_{IN} \leq 24V$ , $T_j=25^{\circ}C$	36	43	-	dB	
Dropout Voltage	$ V_{IN} - V_{OUT} $	1	$T_j=25^{\circ}C$	-	1.7	-	V	
Average Temperature Coefficient of Output Voltage	$TC_{VO}$	1	$I_{OUT}=5mA$	-	-0.9	-	mV/ $^{\circ}C$	

# KIA78L05F ~ KIA78L24F

## ELECTRICAL CHARACTERISTICS

KIA78L12F

(Unless otherwise specified,  $V_{IN}=19V$ ,  $I_{OUT}=40mA$ ,  $C_{IN}=0.33\mu F$ ,  $C_{OUT}=0.1\mu F$ ,  $0^{\circ}C \leq T_j \leq 125^{\circ}C$ )

CHARACTERISTIC	SYMBOL	TEST CIRCUIT	TEST CONDITION	MIN.	TYP.	MAX.	UNIT	
Output Voltage	$V_{OUT}$	1	$T_j=25^{\circ}C$	11.4	12	12.6	V	
Input Regulation	Reg line	1	$T_j=25^{\circ}C$	$14.5V \leq V_{IN} \leq 27V$	-	120	250	mV
				$16V \leq V_{IN} \leq 27V$	-	100	200	
Load Regulation	Reg load	1	$T_j=25^{\circ}C$	$1.0mA \leq I_{OUT} \leq 100mA$	-	20	100	mV
				$1.0mA \leq I_{OUT} \leq 40mA$	-	10	50	
Output Voltage	$V_{OUT}$	1	$14.5V \leq V_{IN} \leq 27V$ $1.0mA \leq I_{OUT} \leq 40mA$	11.16	-	12.84	V	
			$V_{IN}=19V$ , $1.0mA \leq I_{OUT} \leq 70mA$	11.16	-	12.84		
Quiescent Current	$I_B$	1	$T_j=25^{\circ}C$	-	3.2	6.5	mA	
			$T_j=125^{\circ}C$	-	-	6.0		
Quiescent Current Change	$\Delta I_B$	1	$16V \leq V_{IN} \leq 27V$	-	-	1.5	mA	
			$1.0mA \leq I_{OUT} \leq 40mA$	-	-	0.1		
Output Noise Voltage	$V_{NO}$	1	$T_a=25^{\circ}C$ , $10Hz \leq f \leq 100kHz$	-	80	-	$\mu V_{rms}$	
Long Term Stability	$\Delta V_{OUT}/\Delta t$	1		-	24	-	$\frac{mV}{1.0kHrs}$	
Ripple Rejection Ratio	RR	2	$f=120Hz$ , $15V \leq V_{IN} \leq 25V$ , $T_j=25^{\circ}C$	36	41	-	dB	
Dropout Voltage	$ V_{IN} - V_{OUT} $	1	$T_j=25^{\circ}C$	-	1.7	-	V	
Average Temperature Coefficient of Output Voltage	$TC_{VO}$	1	$I_{OUT}=5mA$	-	-1.0	-	$mV/^{\circ}C$	



# KIA78L05F ~ KIA78L24F

## ELECTRICAL CHARACTERISTICS

KIA78L15F

(Unless otherwise specified,  $V_{IN}=23V$ ,  $I_{OUT}=40mA$ ,  $C_{IN}=0.33\mu F$ ,  $C_{OUT}=0.1\mu F$ ,  $0^{\circ}C \leq T_j \leq 125^{\circ}C$ )

CHARACTERISTIC	SYMBOL	TEST CIRCUIT	TEST CONDITION	MIN.	TYP.	MAX.	UNIT	
Output Voltage	$V_{OUT}$	1	$T_j=25^{\circ}C$	14.25	15	15.75	V	
Input Regulation	Reg line	1	$T_j=25^{\circ}C$	$17.5V \leq V_{IN} \leq 30V$	-	130	300	mV
				$20V \leq V_{IN} \leq 30V$	-	110	250	
Load Regulation	Reg load	1	$T_j=25^{\circ}C$	$1.0mA \leq I_{OUT} \leq 100mA$	-	25	150	mV
				$1.0mA \leq I_{OUT} \leq 40mA$	-	12	75	
Output Voltage	$V_{OUT}$	1	$17.5V \leq V_{IN} \leq 30V$ , $1.0mA \leq I_{OUT} \leq 40mA$	13.95	-	16.05	V	
			$V_{IN}=23V$ , $1.0mA \leq I_{OUT} \leq 70mA$	13.95	-	16.05		
Quiescent Current	$I_B$	1	$T_j=25^{\circ}C$	-	3.3	6.5	mA	
			$T_j=125^{\circ}C$	-	-	6.0		
Quiescent Current Change	$\Delta I_B$	1	$20V \leq V_{IN} \leq 30V$	-	-	1.5	mA	
			$1.0mA \leq I_{OUT} \leq 40mA$	-	-	0.1		
Output Noise Voltage	$V_{NO}$	1	$T_a=25^{\circ}C$ , $10Hz \leq f \leq 100kHz$	-	90	-	$\mu V_{rms}$	
Long Term Stability	$\Delta V_{OUT}/\Delta t$	1		-	30	-	$\frac{mV}{1.0kHrs}$	
Ripple Rejection Ratio	RR	2	$f=120Hz$ , $18.5V \leq V_{IN} \leq 28.5V$ , $T_j=25^{\circ}C$	34	40	-	dB	
Dropout Voltage	$ V_{IN} - V_{OUT} $	1	$T_j=25^{\circ}C$	-	1.7	-	V	
Average Temperature Coefficient of Output Voltage	$TC_{VO}$	1	$I_{OUT}=5mA$	-	-1.3	-	$mV/^{\circ}C$	

# KIA78L05F ~ KIA78L24F

## ELECTRICAL CHARACTERISTICS

KIA78L18F

(Unless otherwise specified,  $V_{IN}=27V$ ,  $I_{OUT}=40mA$ ,  $C_{IN}=0.33\mu F$ ,  $C_{OUT}=0.1\mu F$ ,  $0^{\circ}C \leq T_j \leq 125^{\circ}C$ )

CHARACTERISTIC	SYMBOL	TEST CIRCUIT	TEST CONDITION	MIN.	TYP.	MAX.	UNIT	
Output Voltage	$V_{OUT}$	1	$T_j=25^{\circ}C$	7.1	18	18.9	V	
Input Regulation	Reg line	1	$T_j=25^{\circ}C$	$21.4V \leq V_{IN} \leq 33V$	-	32	325	mV
				$22V \leq V_{IN} \leq 33V$	-	27	275	
Load Regulation	Reg load	1	$T_j=25^{\circ}C$	$1.0mA \leq I_{OUT} \leq 100mA$	-	30	170	mV
				$1.0mA \leq I_{OUT} \leq 40mA$	-	15	75	
Output Voltage	$V_{OUT}$	1	$21.4V \leq V_{IN} \leq 33V$ , $1.0mA \leq I_{OUT} \leq 40mA$	16.74	-	19.26	V	
			$V_{IN}=27V$ , $1.0mA \leq I_{OUT} \leq 70mA$	16.74	-	19.26		
Quiescent Current	$I_B$	1	$T_j=25^{\circ}C$	-	3.3	6.5	mA	
			$T_j=125^{\circ}C$	-	-	6.0		
Quiescent Current Change	$\Delta I_B$	1	$22V \leq V_{IN} \leq 33V$	-	-	1.5	mA	
			$1.0mA \leq I_{OUT} \leq 40mA$	-	-	0.1		
Output Noise Voltage	$V_{NO}$	1	$T_a=25^{\circ}C$ , $10Hz \leq f \leq 100kHz$	-	150	-	$\mu V_{rms}$	
Long Term Stability	$\Delta V_{OUT}/\Delta t$	1		-	45	-	mV/ 1.0kHrs	
Ripple Rejection Ratio	RR	2	$f=120Hz$ , $23V \leq V_{IN} \leq 33V$ , $T_j=25^{\circ}C$	32	38	-	dB	
Dropout Voltage	$ V_{IN} - V_{OUT} $	1	$T_j=25^{\circ}C$	-	1.7	-	V	
Average Temperature Coefficient of Output Voltage	$TC_{VO}$	1	$I_{OUT}=5mA$	-	-1.5	-	mV/ $^{\circ}C$	

# KIA78L05F ~ KIA78L24F

## ELECTRICAL CHARACTERISTICS

KIA78L20F

(Unless otherwise specified,  $V_{IN}=29V$ ,  $I_{OUT}=40mA$ ,  $C_{IN}=0.33\mu F$ ,  $C_{OUT}=0.1\mu F$ ,  $0^{\circ}C \leq T_j \leq 125^{\circ}C$ )

CHARACTERISTIC	SYMBOL	TEST CIRCUIT	TEST CONDITION	MIN.	TYP.	MAX.	UNIT	
Output Voltage	$V_{OUT}$	1	$T_j=25^{\circ}C$	19.0	20	21.0	V	
Input Regulation	Reg line	1	$T_j=25^{\circ}C$	$23.5V \leq V_{IN} \leq 35V$	-	33	330	mV
				$24V \leq V_{IN} \leq 35V$	-	28	285	
Load Regulation	Reg load	1	$T_j=25^{\circ}C$	$1.0mA \leq I_{OUT} \leq 100mA$	-	33	180	mV
				$1.0mA \leq I_{OUT} \leq 40mA$	-	17	90	
Output Voltage	$V_{OUT}$	1	$23.5V \leq V_{IN} \leq 35V$ , $1.0mA \leq I_{OUT} \leq 40mA$	18.6	-	21.4	V	
			$V_{IN}=29V$ , $1.0mA \leq I_{OUT} \leq 70mA$	18.6	-	21.4		
Quiescent Current	$I_B$	1	$T_j=25^{\circ}C$	-	3.3	6.5	mA	
			$T_j=125^{\circ}C$	-	-	6.0		
Quiescent Current Change	$\Delta I_B$	1	$24V \leq V_{IN} \leq 35V$	-	-	1.5	mA	
			$1.0mA \leq I_{OUT} \leq 40mA$	-	-	0.1		
Output Noise Voltage	$V_{NO}$	1	$T_a=25^{\circ}C$ , $10Hz \leq f \leq 100kHz$	-	170	-	$\mu V_{rms}$	
Long Term Stability	$\Delta V_{OUT}/\Delta t$	1		-	49	-	mV/ 1.0kHrs	
Ripple Rejection Ratio	RR	2	$f=120Hz$ , $25V \leq V_{IN} \leq 35V$ , $T_j=25^{\circ}C$	31	37	-	dB	
Dropout Voltage	$ V_{IN} - V_{OUT} $	1	$T_j=25^{\circ}C$	-	1.7	-	V	
Average Temperature Coefficient of Output Voltage	$TC_{VO}$	1	$I_{OUT}=5mA$	-	-1.7	-	mV/ $^{\circ}C$	

# KIA78L05F ~ KIA78L24F

## ELECTRICAL CHARACTERISTICS

KIA78L24F

(Unless otherwise specified,  $V_{IN}=33V$ ,  $I_{OUT}=40mA$ ,  $C_{IN}=0.33\mu F$ ,  $C_{OUT}=0.1\mu F$ ,  $0^{\circ}C \leq T_j \leq 125^{\circ}C$ )

CHARACTERISTIC	SYMBOL	TEST CIRCUIT	TEST CONDITION	MIN.	TYP.	MAX.	UNIT	
Output Voltage	$V_{OUT}$	1	$T_j=25^{\circ}C$	22.8	24	25.2	V	
Input Regulation	Reg line	1	$T_j=25^{\circ}C$	$27.5V \leq V_{IN} \leq 38V$	-	35	350	mV
				$28V \leq V_{IN} \leq 38V$	-	30	300	
Load Regulation	Reg load	1	$T_j=25^{\circ}C$	$1.0mA \leq I_{OUT} \leq 100mA$	-	40	200	mV
				$1.0mA \leq I_{OUT} \leq 40mA$	-	20	100	
Output Voltage	$V_{OUT}$	1	$27.5V \leq V_{IN} \leq 38V$ $1.0mA \leq I_{OUT} \leq 40mA$	22.32	-	25.68	V	
			$V_{IN}=33V$ , $1.0mA \leq I_{OUT} \leq 70mA$	22.32	-	25.68		
Quiescent Current	$I_B$	1	$T_j=25^{\circ}C$	-	3.5	6.5	mA	
			$T_j=125^{\circ}C$	-	-	6.0		
Quiescent Current Change	$\Delta I_B$	1	$28V \leq V_{IN} \leq 38V$	-	-	1.5	mA	
			$1.0mA \leq I_{OUT} \leq 40mA$	-	-	0.1		
Output Noise Voltage	$V_{NO}$	1	$T_a=25^{\circ}C$ , $10Hz \leq f \leq 100kHz$	-	200	-	$\mu V_{rms}$	
Long Term Stability	$\Delta V_{OUT}/\Delta t$	1		-	56	-	mV/ 1.0kHrs	
Ripple Rejection Ratio	RR	2	$f=120Hz$ , $29V \leq V_{IN} \leq 39V$ , $T_j=25^{\circ}C$	31	35	-	dB	
Dropout Voltage	$ V_{IN} - V_{OUT} $	1	$T_j=25^{\circ}C$	-	1.7	-	V	
Average Temperature Coefficient of Output Voltage	$TC_{VO}$	1	$I_{OUT}=5mA$	-	-2.0	-	mV/ $^{\circ}C$	

# KIA78L05F ~ KIA78L24F

## TEST CIRCUIT/STANDARD APPLICATION CIRCUIT

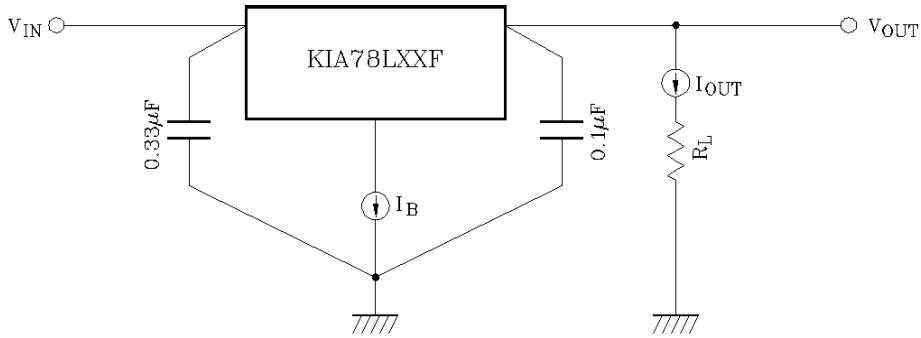

## TEST CIRCUIT

1.  $V_{OUT}$ ,  $R_{eg \cdot line}$ ,  $R_{eg \cdot load}$ ,  $V_{OUT}$ ,  $I_B$ ,  $\Delta I_B$ ,  $V_{NO}$ ,  $\Delta V_{OUT} / \Delta t$ ,  $|V_{IN} - V_{OUT}|$ ,  $TC_{VO}$

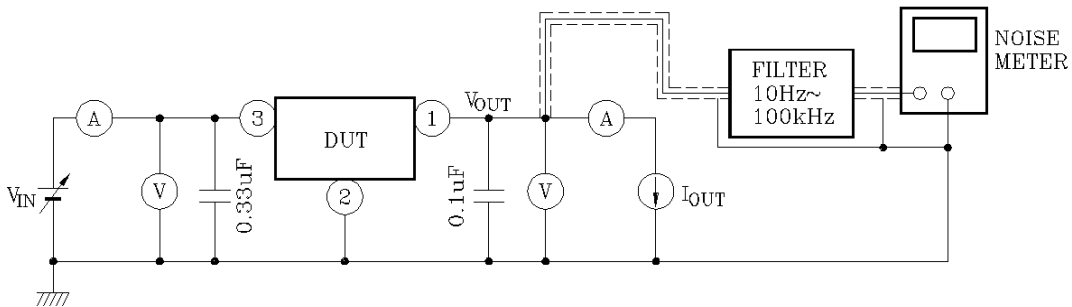

2. RR

$$e_i = 1V_{p-p}$$

$$f = 120Hz$$

$$l \leq 30cm$$

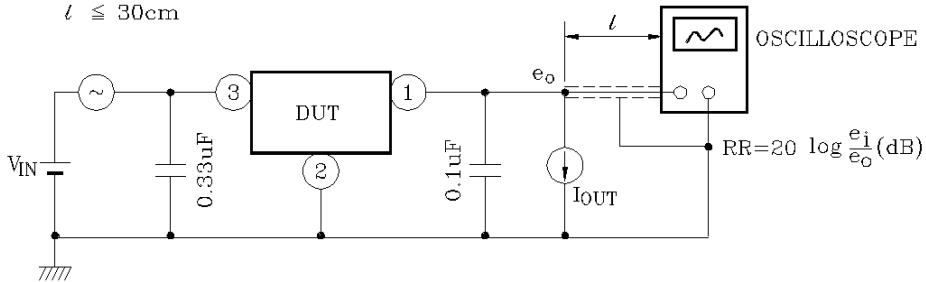

# KIA78L05F ~ KIA78L24F

## EXAMPLES OF TYPICAL CIRCUIT

### (1) STANDARD APPLICATION

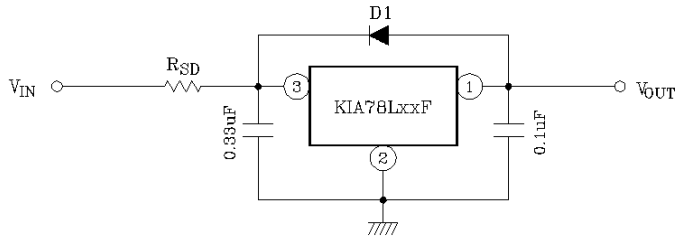

D1 : Protection Diode  
High speed diode D1 should be connected as shown in the figure if the condition  $V_{IN} < V_{OUT}$  might occur by surge voltage or power supply ON/OFF.

$R_{SD}$  : Power limiting resistor for large  $V_{IN}$ , resistor  $R_{SD}$  is needed to limit IC power dissipation.

### (2) A. CURRENT BOOST VOLTAGE REGULATOR

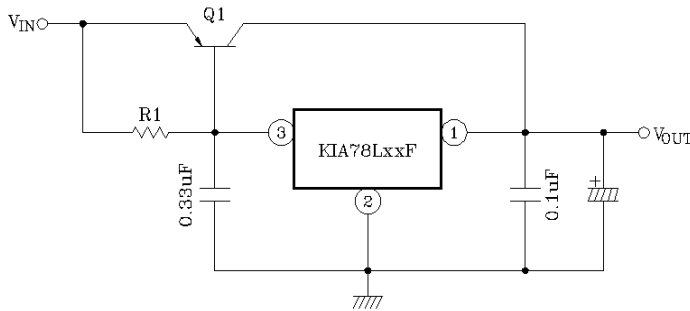

Heat sink is needed for Q1

$$R1 \leq \frac{V_{BE1}}{I_{B(MAX)}}$$

where,  $V_{BE1}$  :  $V_{BE}$  of external transistor Q1

$I_{B(MAX)}$  : Quiescent current of IC

### B. SHORT-CIRCUIT PROTECTION

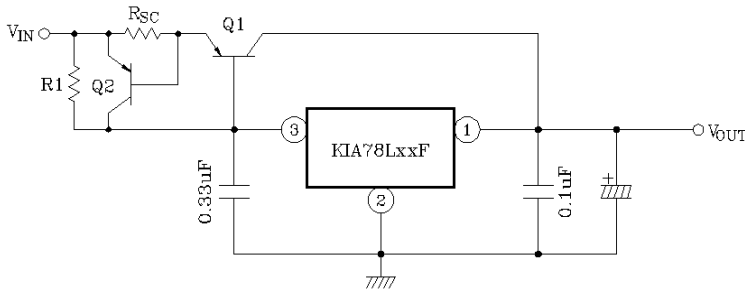

$$R_{SC} = \frac{V_{BE2}}{I_{SC}}$$

where,  $I_{SC}$  : Short-Circuit current

### (3) CURRENT REGULATOR

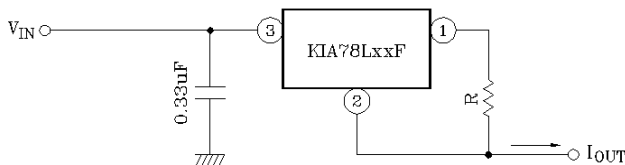

$$I_{OUT} = \frac{V_{OUT}}{R} + I_B$$

# KIA78L05F ~ KIA78L24F

## (4) VOLTAGE BOOST REGULATOR

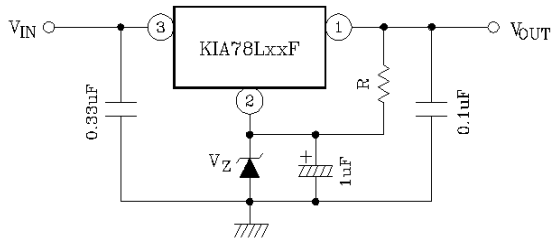

$V_{OUT} = V_Z + V_{OUT} \text{ (of IC)}$   
 Apply current of several mA to R.

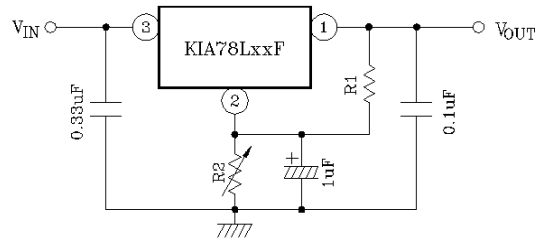

$$V_{OUT} = R_2 \left( I_B + \frac{V_{OUT} \text{ (of IC)}}{R_1} \right) + V_{OUT} \text{ (of IC)}$$

## (5) NEGATIVE REGULATOR

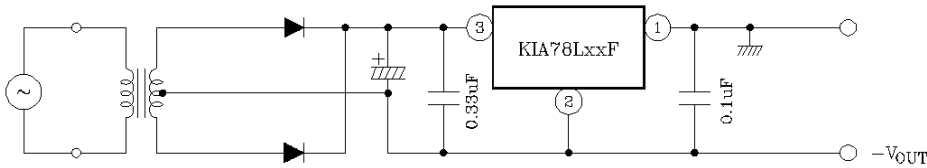

## (6) POSITIVE AND NEGATIVE REGULATOR

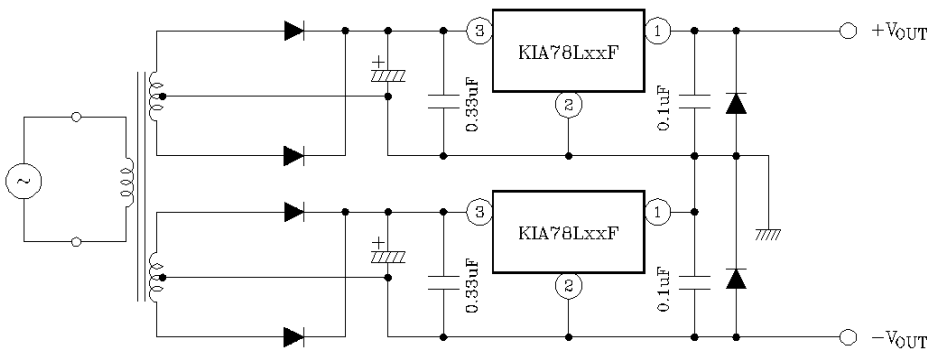

# KIA78L05F ~ KIA78L24F

## PRECAUTIONS FOR USE

When such a high voltage as exceeds 10V beyond the fixed output voltage(Typ. value) of is applied to its output terminal, IC may be destroyed. In this case, connect a zener diode between the output terminal and GND to prevent application of excessive voltage. In particular, in such a current boosting circuit as shown in application circuit example(2), if input voltage is suddenly applied by stages and furthermore load is light, excessive voltage may be applied transiently to the output terminal of IC. In such a case as this, it may become necessary to increase capacity of output capacitor as appropriate, use a smaller R1(a resistor for bypassing IC bias current) or gradually rise input voltage in addition to use of a zener diode as mentioned above.

## SOLDERING

### Flat Package (SOT-89 Package)

Elements mounting styles of electronic devices are gaining in further diversification over recent years, and needs for components are all the more expanding in varieties. Especially, surface mounting is steadily penetrating into industrial segments as a world-wide popular technical trend. Although exposure to high temperature is inevitable during soldering we recommend limiting the soldering temperature to low levels as shown in figure for the sake of retaining inherent excellent reliability.

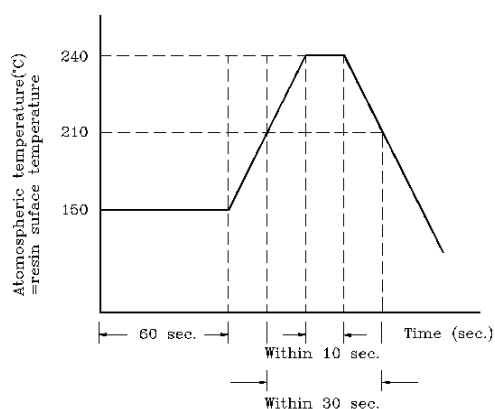

#### (a) When employing solder reflow method

- ① Atmospheric temperature around resin surfaces must be less than 240°C, not exceeding the time length of 10 sec.
- ② Recommend temperature profile
- ③ Precautions on heating method

When resin is kept exposed to high temperature for a long time, device reliability may be marred. Therefore, it is essential to complete soldering in the shortest time possible to prevent temperature of resin from rising.

#### (b) When employing halogen lamps or infrared-ray heaters

When halogen lamps or infrared-ray heaters are used, avoid direct irradiation onto resin surfaces; such devices cause extensive localized temperature rise.

※ Please keep a reflow solder operating when SOT-89 package's soldering.



# KIA78L05F ~ KIA78L24F

