



ICM7101D LOW COST SINGLE CHIP TELEPHONE IC

FEATURES

- Include Dialer, Speech, and Ringer Circuit in Single Chip, Replacing Two or More ICs
- Single Board Design Meets Multiple PTT Requirements.
- Operating Range From 15 to 100mA
- Selectable Make-Break Ratio
- Tone/Pulse Dialing
- 32 Digit Last Number Redial
- Ring Frequency Discrimination
- 2-tones Melody Generator

OVERVIEW

ICM7101D is a single chip telephone CMOS integrated circuits that meets multiple PTT requirements, allowing phone manufacturers to have single board design for various countries. This reduces inventory and simplify manufacturing processes.

ICM7101D integrates dialer, speech, and ringer circuits. The integration reduces component counts, hence increases product reliability.

TYPICAL APPLICATION CIRCUIT

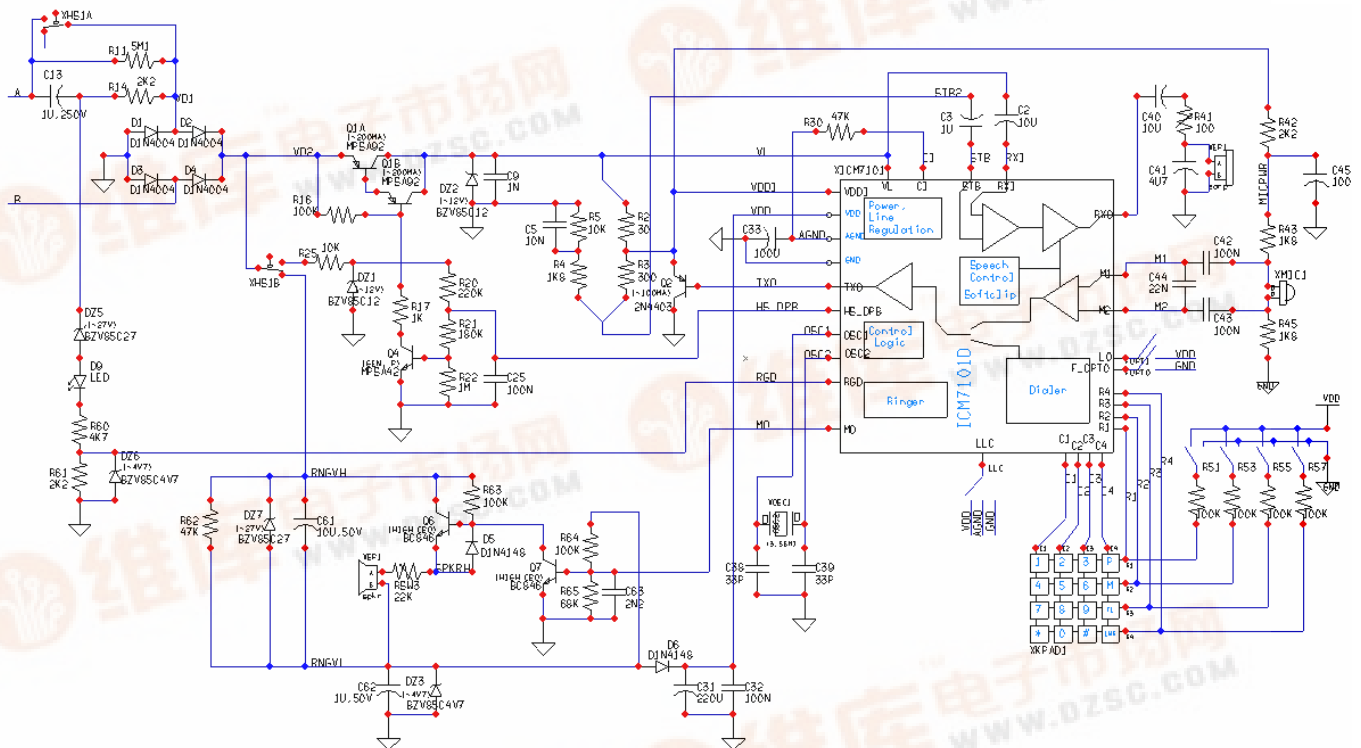
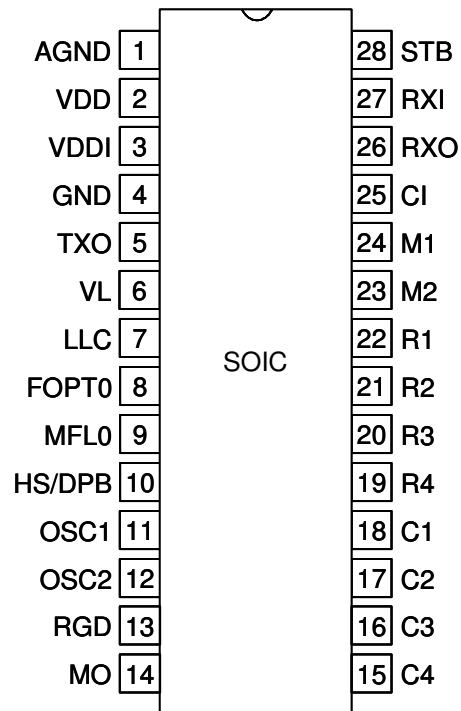

Figure 1: Typical Application Circuit



PACKAGE
28-Lead SOIC



PIN DESCRIPTION

Pin No	Symbol	Description
1	AGND	Analog Ground
2	VDD	Supply Voltage
3	VDDI	Supply Input Voltage Power for the chip is extracted from this pin
4	GND	Ground
5	TXO	Transmit Output Transmit output to be connected to external power transistor for the modulation of line voltage and for shorting the line during make period of pulse dialing.
6	VL	Line Voltage
7	LLC	Line Loss Compensation 0V = No LLC; AGND=Low LLC; VDD=High LLC.
8	FOPT0	Flash Option FOPT0=0 - 100ms FOPT0=1 - 600ms
9	MFL0	DTMF Level Option MFL0=0 - Low DTMF (~ -8/-10dB for ZAC=600ohm) MFL0=1 - High DTMF (~ -6/-8dB for ZAC=600ohm)
10	HS/DPB	Hook Switch Input and Dial Pulse Output When off-hook, this pin is pulled high by the hook switch. During pulse dialing, this pin is pulled low during break periods.
11	OSC1	Oscillator Input 3.58MHz ceramic resonator input.
12	OSC2	Oscillator Output
13	RGD	Ring Detection Input Input for ring frequency detection.
14	MO	Melody Output Melody pulse output for tone ringer.
15	C4	Keypad Columns Keypad column inputs.
16	C3	
17	C2	
18	C1	
19	R4	Keypad Rows Keypad rows. These pins are also used to determine the operating mode.
20	R3	
21	R2	
22	R1	
23	M2	Microphone Inputs Input for electret microphone.
24	M1	
25	CI	Complex Impedance and AC Impedance Input Placing 47Kohm resistor between CI and AGND pins sets the AC impedance around 600ohm. The higher the resistor the higher the AC impedance. Lower resistor results in lower AC impedance.
26	R XO	Receive Output These outputs drive a dynamic earpiece.
27	R XI	Receive Input Input for received signal.
28	STB	Side Tone Balance Input Side tone cancellation input.

FUNCTIONAL DESCRIPTION

SYSTEM STARTUP

ICM7101D generates internal power-on-reset when VDD reaches around 1.5V. Power-on-reset appropriately initiates the system to a known initial state.

ICM7101D stays in shutdown mode so long as HS/DPB pin stays LOW. However, the ringer circuitry is activated in this mode to monitor the incoming ringing signal.

OSCILATOR

All the timing of ICM7101D is based on a clock frequency of 3.58 MHz. A Crystal or Ceramic resonator of this frequency should be connected to oscillator pins of ICM7101D. Care has to be taken in selecting this components since in practise minor deviations from the nominal frequency may occur due to the characteristics of the frequency reference device used.

It is recommended to connect a small value capacitors ($\leq 47\text{pF}$) in parallel with the Frequency Reference to ensure start-up and or operation at the nominal frequency.

TONE RINGER

The tone ringer of ICM7101D consists of Ring Detection Circuit and Melody Generator Circuit.

Ring Detection Circuit

Ring Detection circuit will assures the signal that present on RGD pin input is valid. The signal is considered as a valid signal if the signal has frequencies between 13Hz and 70Hz.

Melody Generator

Once the valid ring signal is detected on the Ring Detection (RGD) pin and is present for about 75 ms continuously, the melody generator will be activated, the ring signal will be monitored continuously and the melody generator will be immediately turn on or off according to the momentary presence of a valid or invalid ring signal respectively until next power on reset or off-hook. The melody generator of ICM7101D creates 2 frequencies of 874Hz, and 1250Hz.

SPEECH NETWORK

The speech network of ICM7101D consists of a transmitter and a receiver path, side tone cancellation and line loss compensation.

As soon as the phone goes off-hook (i.e. when HS/DPB pin goes HIGH), causing ICM7101D to activate the whole circuit except the ringer which becomes deactivated.

Transmit

For 600 ohm termination, the transmit gain from microphone input to the line voltage is 35dB. The output at VL pin is clamped at 2Vpp.

Receive

Receive path gain is 3dB for 600 ohm termination. Soft clip circuitry limits the output at RO pins to 2Vpp. This avoids unpleasant harsh distortion.

Side Tone Cancellation

As shown in the typical application circuit, side tone cancellation can be achieved best by balancing the Whitestone bridge of R2, R3, R4+R5//C5, and line impedance.

Line Loss Compensation

LLC input level is scanned as the phone goes off-hook (i.e. as HD/DPB pin goes HIGH). At the same time, the loop current level is sensed and determined. If LLC=0, no compensation scheme is in effect.

If LLC=AGND, "low" compensation scheme is in effect. Transmit and receive gains are reduced by as much as 6dB when the loop current exceeds 50mA.

If LLC=VDD, "high" compensation scheme is in effect. Transmit and receive gains are reduced by as much as 6dB when the loop current exceeds 75mA.

AC Impedance

Placing 47Kohm resistor between CI and AGND pins sets the AC Impedance to be about 600ohm. Increasing the resistor value increases the impedance. Similarly, lowering the resistor value will lower the impedance.

DTMF Level

When the AC Impedance is set to 600ohm, DTMF Level is determined by MFL0 pin as follow:

MFL0	DTMF Level
0	-8/-10 dB
1	-6/-8 dB

DIALING FUNCTIONS

Keypad arrangement is as shown in the typical application circuit in Figure 1. Dialing modes are selectable using the pull-up/pull-down resistors connected to the row inputs. As soon as the phone goes off-hook (i.e when HS/DPB pin goes HIGH), voltage levels on keypad row inputs (R1 thru R4) are first scanned to determine the operating mode as follow:

Pin	Function	Level – Mode
R1	Dialing Mode	0 – MF mode 1 – LD mode
R2	LD Period	0 – 10 PPS 1 – 20 PPS
R3	Make/Break Ratio	0 – 33/67 1 – 40/60
R4	DTMF option	0 – 82ms/82ms 1 – 82ms/160ms

Valid Keys

ICM7101D has a total of 15 valid keys. It scans the keys by asserting known state on pins R1, R2, R3, and R4 in sequence, and check which column (pins C1, C2, C3, C4) is shorted to which row. The following specify the combinations:

	C1	C2	C3	C4
R1	1	2	3	Pause
R2	4	5	6	Mute
R3	7	8	9	Flash
R4	*	0	#	LNR

DTMF Tones

The DTMF Tone Generator creates 12 tones in compliance with CCITT Recommendation. There are two group of frequencies of DTMF tones. The low group depends on the key's row, while the high group depends on the key's column as illustrated in the following table:

	C1	C2	C3	Low Freq
R1	1	2	3	697 Hz
R2	4	5	6	770 Hz
R3	7	8	9	852 Hz
R4	*	0	#	941 Hz
High Freq	1209 Hz	1336 Hz	1477 Hz	

Last Number Redial (LNR)

The last Number Redial (LNR) is a facility of ICM7101D to allow resignalling of the last manually dialled number without keying in all digits again. The LNR is repeatable after each off-hook.

A manually entered number is stored in a RAM of ICM7101D. The capacity of RAM is 32 digits.

Flash

ICM7101D assert line break (pull down HS/DPB pin) when Flash key is depressed. The flash duration depends on the FOPT0 as follow:

FOPT0	Flash Duration
0	100 ms
1	600 ms

Mute

ICM7101D turns off the microphone input from M1 and M2 pins when Mute key is depressed. Depressing the key again toggle the mute function.

Pause

ICM7101D pauses (no dialing and microphone is muted) for 2.2 seconds when Pause key is depressed.

ABSOLUTE MAXIMUM RATING

Symbol	Parameter	Value	Unit
V _{DDI}	Supply Line Voltage	-0.3 to 7.0	V
V _{IN}	Digital Input Voltage	-0.3 to 7.0	V
T _{STG}	Storage Temperature	-55 to +150	°C
T _{SOL}	Soldering Temperature	300	°C

Note 1: Stress greater than those listed under ABSOLUTE MAXIMUM RATINGS may cause permanent damage to the device. This is a stress rating only and functional operation of the device at these or any other conditions above those indicated in the operational sections of this specification is not implied. Exposure to absolute maximum rating conditions for extended periods may affect reliability.

OPERATING RANGE

Range	Ambient Temperature
Commercial	-25 °C to 70 °C

ELECTRICAL CHARACTERISTICS

(I_{LINE} = 15mA unless otherwise specified)

Symbol	Parameter	Test Conditions	Min	Typ	Max	Unit
V _{LI}	Line Voltage (default)	I _{LINE} : 13mA to 100mA		4.5		V
I _{DD}	Operating Current	Speech mode		3		mA
		Tone Dialing		4		mA
		Pulse Dialing	V _{DD} = 2.5V	0.2		mA
		Ring mode	V _{DD} = 2.5V	0.3		mA
I _{OL}	Output Current, Sink TXD, HS/DPB, MO	V _{OL} = 0.4V		1.5		mA
V _{IL}	Input Voltage Low	HS/DPB, RGD T _A =25°C	V _{SS}		0.3	V _{DD}
V _{IH}	Input Voltage High	HS/DPB, RGD T _A =25°C	0.7		1	V _{DD}
Transmit (TX)						
G _{TX}	Transmit Gain		34	35	36	dB
THD	Distortion	V _{IL} < 0.5 V _{RMS}			2	%
V _{AGC}	Soft Clip Level			2		V _{pp}
Z _{IN}	Input Impedance			20		KΩ
G _{MUTE}	Mute Attenuation	Mute activated	60			dB
V _{IN MAX}	Input Voltage Range	Differential Single Ended		+/- 1 +/- 0.5		V _{pp} V _{DD}
Receive (RX)						
G _{RX}	Receive Gain		2	3	6	dB
THD	Distortion	V _{RXI} < 0.5 V _{RMS}			2	%
V _{AGC}	Soft Clip Level			2		V _{pp}
Z _{IN}	Input Impedance (RI)			8		KΩ
V _{IN RI}	Input Voltage Range			+/- 2		V _{PEAK}
Output Driver (BJT)						
V _{IN MAX}	Input Voltage Range			+/- 2		V _{PEAK}
V _{TX}	Dynamic Range			+/- 2		V _{PEAK}
RL	Return Loss	Z _{RL} = 1000Ω	18			dB
Side Tone (ST)						
G _{ST}	Side Tone Cancellation		26			dB
V _{IN ST}	Input Voltage Range			+/- 2		V _{PEAK}

Keyboard						
t_D	Key debounce time			64		ms
HS/DPB INPUT						
t_{HS-L}	Low to High Debounce	Going off-hook		15		ms
t_{HS-H}	High to Low Debounce	Going on-hook		15		ms
Tone Ringer						
V_{MO}	Melody Output			PDM		
t_{MD}	Melody Delay				10	ms
F1	Frequency 1			874		Hz
F2	Frequency 2			1250		Hz
t_{DT}	Detection Time	Ring Freq = 20Hz	50		80	ms
f_{MIN}	Min. Detection Frequency		13			Hz
f_{MAX}	Max. Detection Frequency				70	Hz
DTMF						
F	Frequency Deviation	note 5	-0.31		+0.75	%
t_{TD}	Tone Duration	note 1	80	82	84	ms
t_{TP}	Inter Tone Pause	note 1	80	82	84	ms

Note 1: The values are valid during automatic dialing and are minimum values during manual dialing, i.e. the tones will continue as long as the key is depressed.

Note 3: Relative to high group

Note 5: This does not include the frequency deviation of the ceramic resonator.

APPENDIX A: TYPICAL APPLICATION CIRCUIT

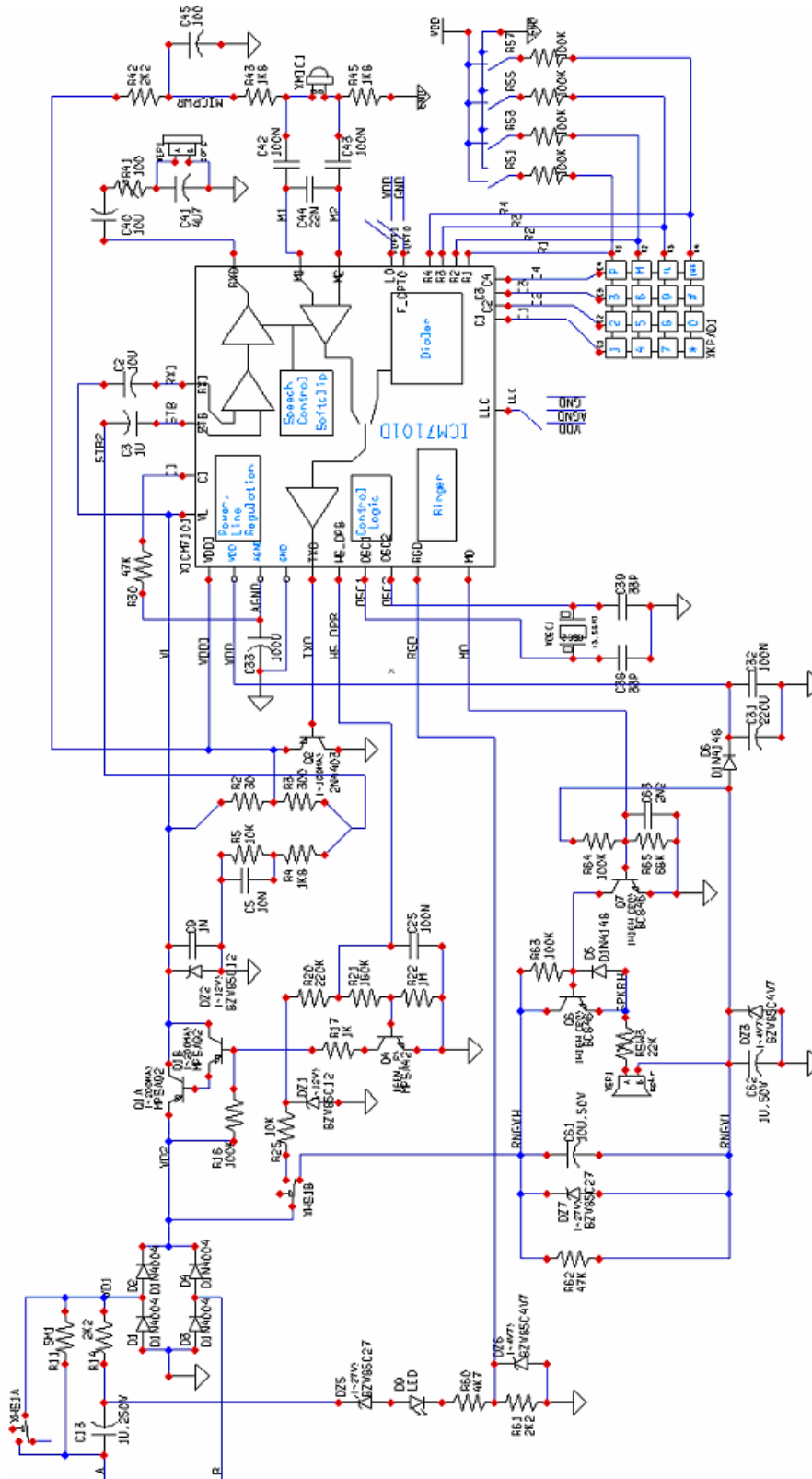

PACKAGE INFORMATION

28-Lead SOIC (Unit: Inches)

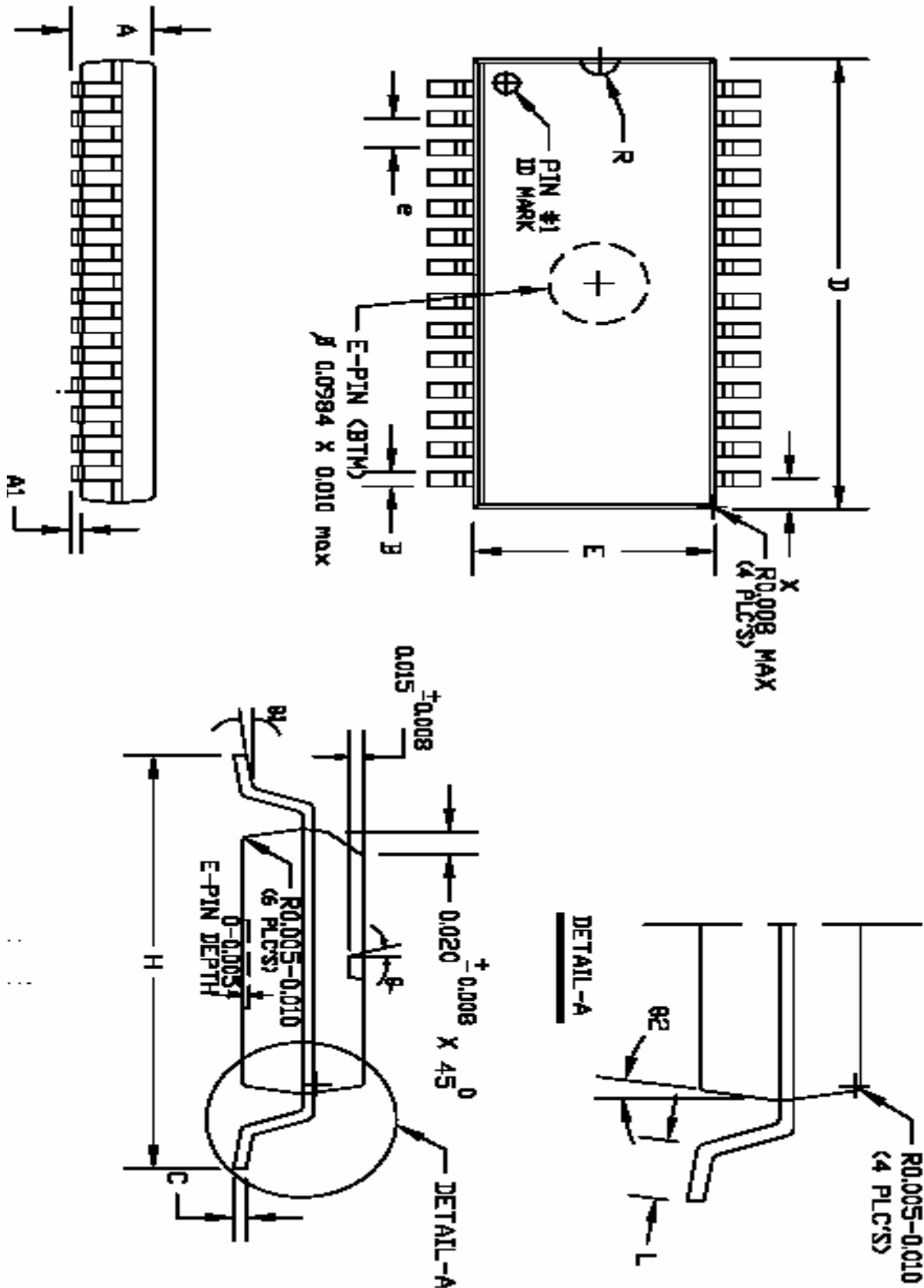

SYMBOL	28 SOIC	
	MIN	MAX
A	0.096	0.104
A1	0.004	0.012
B	0.014	0.020
D	0.698	0.706
E	0.291	0.299
H	0.398	0.414
e	0.050 BSC	
C	0.009	0.011
L	0.020	0.040
X	0.026 REF	
R	0.025	0.035
Q	7° BSC	
Q1	0°	8°
B2	7° BSC	

NOTE:

- 1) LEAD COPLANARITY SHOULD BE 0 TO 0.10MM (0.004") MAX.
- 2) PACKAGE SURFACE FINISHING:
 - (2.1) TOP: MATTE (CHARMILLES # 24-27)
 - (2.2) ALL SIDE: MATTE (CHARMILLES # 24-27)
 - (2.3) BOTTOM: MATTE (CHARMILLES # 24-27)
- 3) ALL DIMENSIONS EXCLUDING MOLD FLASHES.
- 4) MAX DEVIATION OF CENTER OF PACKAGE AND CENTER OF LEADFRAME TO BE 0.10MM (0.004").
- 5) MAX MISALIGNMENT BETWEEN TOP AND BTM CENTER OF PACKAGE TO BE 0.10MM (0.004").



ICM7101D

LOW COST SINGLE CHIP TELEPHONE IC

DISCLAIMER

The information contained herein is current as of the date of publication; however, delivery of this document shall not under any circumstances create any implication that the information contained herein is correct as of any time subsequent to such date. ICmic reserves the right to make changes without notification, even if such changes would render information contained herein inaccurate or incomplete. ICmic makes no representation or warranty that any circuit designed by reference to the information contained herein, will function without errors and as intended by the designer.