

SONY

ICX039DNA

Diagonal 8mm (Type 1/2) CCD Image Sensor for PAL Color Video Cameras

Description

The ICX039DNA is an interline CCD solid-state image sensor suitable for PAL color video cameras with a diagonal 8mm (Type 1/2) system. Smear, sensitivity, D-range, S/N and other characteristics have been greatly improved compared with the ICX039BNA. High sensitivity and low dark current are achieved through the adoption of Ye, Cy, Mg and G complementary color mosaic filters and HAD (Hole-Accumulation Diode) sensors.

This chip features a field period readout system and an electronic shutter with variable charge-storage time.

This chip is compatible with and can replace the ICX039BNA.

Features

- Low smear (-20dB compared with the ICX039BNA)
- High sensitivity (+3.0dB compared with the ICX039BNA)
- High D range (+2.5dB compared with the ICX039BNA)
- High S/N
- High resolution and low dark current
- Excellent antiblooming characteristics
- Ye, Cy, Mg, and G complementary color mosaic filters on chip
- Continuous variable-speed shutter
- Substrate bias: Adjustment free (external adjustment also possible with 6 to 14V)
- Reset gate pulse: 5Vp-p adjustment free (drive also possible with 0 to 9V)
- Horizontal register: 5V drive

Device Structure

- Interline CCD image sensor
- Image size: Diagonal 8mm (Type 1/2)
- Number of effective pixels: 752 (H) x 582 (V) approx. 440K pixels
- Total number of pixels: 795 (H) x 596 (V) approx. 470K pixels
- Chip size: 7.95mm (H) x 6.45mm (V)
- Unit cell size: 8.6µm (H) x 8.3µm (V)
- Optical black: Horizontal (H) direction : Front 3 pixels, rear 40 pixels
Vertical (V) direction : Front 12 pixels, rear 2 pixels
- Number of dummy bits: Horizontal 22
Vertical 1 (even fields only)
- Substrate material: Silicon

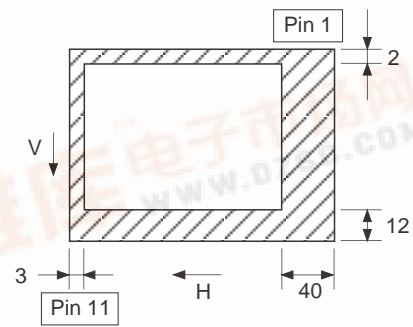
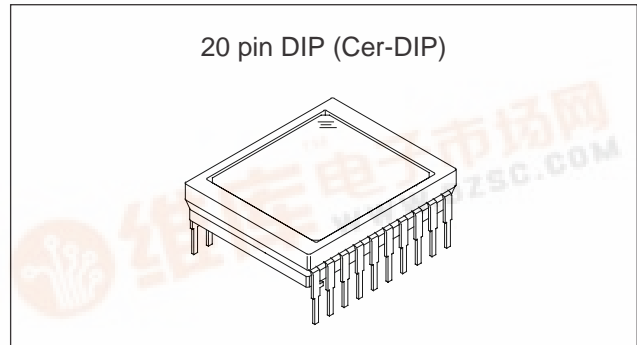

Optical black position (Top View)



Block Diagram and Pin Configuration

(Top View)

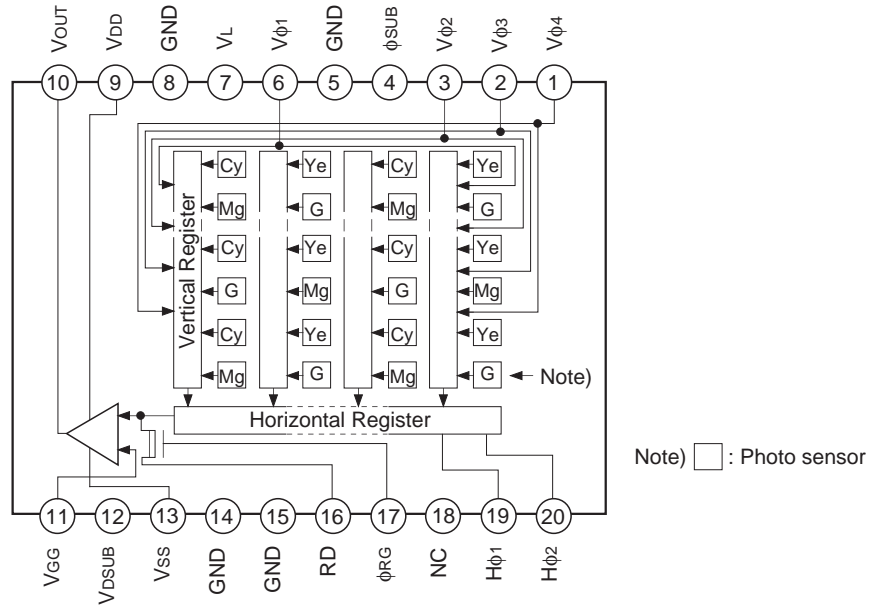

Pin Description

| Pin No. | Symbol | Description | Pin No. | Symbol | Description |
|---------|--------------|----------------------------------|---------|-------------|---------------------------------------|
| 1 | $V\phi_4$ | Vertical register transfer clock | 11 | V_{GG} | Output circuit gate bias |
| 2 | $V\phi_3$ | Vertical register transfer clock | 12 | V_{DSUB} | Substrate bias circuit supply voltage |
| 3 | $V\phi_2$ | Vertical register transfer clock | 13 | V_{SS} | Output circuit source |
| 4 | ϕ_{SUB} | Substrate clock | 14 | GND | GND |
| 5 | GND | GND | 15 | GND | GND |
| 6 | $V\phi_1$ | Vertical register transfer clock | 16 | RD | Reset drain bias |
| 7 | V_L | Protective transistor bias | 17 | ϕ_{RG} | Reset gate clock |
| 8 | GND | GND | 18 | NC | |
| 9 | V_{DD} | Output circuit supply voltage | 19 | $H\phi_1$ | Horizontal register transfer clock |
| 10 | V_{OUT} | Signal output | 20 | $H\phi_2$ | Horizontal register transfer clock |

Absolute Maximum Ratings

| Item | | Ratings | Unit | Remarks |
|--|--|-------------|------|---------|
| Substrate clock $\phi_{SUB} - GND$ | | -0.3 to +50 | V | |
| Supply voltage | $V_{DD}, V_{RD}, V_{DSUB}, V_{OUT}, V_{SS} - GND$ | -0.3 to +18 | V | |
| | $V_{DD}, V_{RD}, V_{DSUB}, V_{OUT}, V_{SS} - \phi_{SUB}$ | -55 to +10 | V | |
| Clock input voltage | $V\phi_1, V\phi_2, V\phi_3, V\phi_4 - GND$ | -15 to +20 | V | |
| | $V\phi_1, V\phi_2, V\phi_3, V\phi_4 - \phi_{SUB}$ | to +10 | V | |
| Voltage difference between vertical clock input pins | | to +15 | V | *1 |
| Voltage difference between horizontal clock input pins | | to +17 | V | |
| $H\phi_1, H\phi_2 - V\phi_4$ | | -17 to +17 | V | |
| $\phi_{RG}, V_{GG} - GND$ | | -10 to +15 | V | |
| $\phi_{RG}, V_{GG} - \phi_{SUB}$ | | -55 to +10 | V | |
| $V_L - \phi_{SUB}$ | | -65 to +0.3 | V | |
| Pins other than GND and $\phi_{SUB} - V_L$ | | -0.3 to +30 | V | |
| Storage temperature | | -30 to +80 | °C | |
| Operating temperature | | -10 to +60 | °C | |

*1 +27V (Max.) when clock width < 10 μ s, clock duty factor < 0.1%.

Bias Conditions 1 [when used in substrate bias internal generation mode]

| Item | Symbol | Min. | Typ. | Max. | Unit | Remarks |
|---------------------------------------|-------------------|-----------------------------|------|-------|------|-----------------------------------|
| Output circuit supply voltage | V _{DD} | 14.55 | 15.0 | 15.45 | V | |
| Reset drain voltage | V _{RD} | 14.55 | 15.0 | 15.45 | V | V _{RD} = V _{DD} |
| Output circuit gate voltage | V _{GG} | 1.75 | 2.0 | 2.25 | V | |
| Output circuit source | V _{SS} | Grounded with 390Ω resistor | | | | |
| Protective transistor bias | V _L | *1 | | | | |
| Substrate bias circuit supply voltage | V _{DSUB} | 14.55 | 15.0 | 15.45 | V | |
| Substrate clock | φ _{SUB} | *2 | | | | |

*1 V_L setting is the V_{VL} voltage of the vertical transfer clock waveform, or the same supply voltage as the V_L power supply for the V driver should be used. (When CXD1267AN is used.)

*2 Do not apply a DC bias to the substrate clock pin, because a DC bias is generated within the CCD.

Bias Conditions 2 [when used in substrate bias external adjustment mode]

| Item | Symbol | Min. | Typ. | Max. | Unit | Remarks |
|--|-------------------|-----------------------------|------|-------|------|-----------------------------------|
| Output circuit supply voltage | V _{DD} | 14.55 | 15.0 | 15.45 | V | |
| Reset drain voltage | V _{RD} | 14.55 | 15.0 | 15.45 | V | V _{RD} = V _{DD} |
| Output circuit gate voltage | V _{GG} | 1.75 | 2.0 | 2.25 | V | |
| Output circuit source | V _{SS} | Grounded with 390Ω resistor | | | | |
| Protective transistor bias | V _L | *3 | | | | |
| Substrate bias circuit supply voltage | V _{DSUB} | *4 | | | | |
| Substrate voltage adjustment range | V _{SUB} | 6.0 | | 14.0 | V | *5 |
| Substrate voltage adjustment precision | ΔV _{SUB} | -3 | | +3 | % | *5 |

*3 V_L setting is the V_{VL} voltage of the vertical transfer clock waveform, or the same supply voltage as the V_L power supply for the V driver should be used. (When CXD1267AN is used.)

*4 Connect to GND or leave open.

*5 The setting value of the substrate voltage (V_{SUB}) is indicated on the back of the image sensor by a special code. When adjusting the substrate voltage externally, adjust the substrate voltage to the indicated voltage. The adjustment precision is ±3%. However, this setting value has not significance when used in substrate bias internal generation mode.

V_{SUB} code — one character indication

Code and optimal setting correspond to each other as follows.

| V _{SUB} code | E | f | G | h | J | K | L | m | N | P | Q | R | S | T | U | V | W |
|-----------------------|-----|-----|-----|-----|-----|-----|-----|-----|------|------|------|------|------|------|------|------|------|
| Optimal setting | 6.0 | 6.5 | 7.0 | 7.5 | 8.0 | 8.5 | 9.0 | 9.5 | 10.0 | 10.5 | 11.0 | 11.5 | 12.0 | 12.5 | 13.0 | 13.5 | 14.0 |

<Example> "L" → V_{SUB} = 9.0V

DC Characteristics

| Item | Symbol | Min. | Typ. | Max. | Unit | Remarks |
|-------------------------------|-----------------|------|------|------|------|---------|
| Output circuit supply current | I _{DD} | | 5.0 | 10.0 | mA | |

Clock Voltage Conditions

| Item | Symbol | Min. | Typ. | Max. | Unit | Waveform diagram | Remarks |
|-----------------------------------|--------------------------------------|-------|------|-------|------|--------------------|--|
| Readout clock voltage | V_{VT} | 14.55 | 15.0 | 15.45 | V | 1 | |
| Vertical transfer clock voltage | V_{VH1}, V_{VH2} | -0.05 | 0 | 0.05 | V | 2 | $V_{VH} = (V_{VH1} + V_{VH2})/2$ |
| | V_{VH3}, V_{VH4} | -0.2 | 0 | 0.05 | V | 2 | |
| | $V_{VL1}, V_{VL2}, V_{VL3}, V_{VL4}$ | -9.6 | -9.0 | -8.5 | V | 2 | $V_{VL} = (V_{VL3} + V_{VL4})/2$ |
| | $V_{\phi V}$ | 8.3 | 9.0 | 9.65 | Vp-p | 2 | $V_{\phi V} = V_{VHn} - V_{VLn} (n = 1 \text{ to } 4)$ |
| | $ V_{VH1} - V_{VH2} $ | | | 0.1 | V | 2 | |
| | $V_{VH3} - V_{VH}$ | -0.25 | | 0.1 | V | 2 | |
| | $V_{VH4} - V_{VH}$ | -0.25 | | 0.1 | V | 2 | |
| | V_{VHH} | | | 0.5 | V | 2 | High-level coupling |
| | V_{VHL} | | | 0.5 | V | 2 | High-level coupling |
| | V_{VLH} | | | 0.5 | V | 2 | Low-level coupling |
| V_{VLL} | | | 0.5 | V | 2 | Low-level coupling | |
| Horizontal transfer clock voltage | $V_{\phi H}$ | 4.75 | 5.0 | 5.25 | Vp-p | 3 | |
| | V_{HL} | -0.05 | 0 | 0.05 | V | 3 | |
| Reset gate clock voltage*1 | V_{RGL} | *1 | | | V | 4 | |
| | $V_{\phi RG}$ | 4.5 | 5.0 | 5.5 | Vp-p | 4 | |
| | $V_{RGLH} - V_{RGLL}$ | | | 0.8 | V | 4 | Low-level coupling |
| Substrate clock voltage | $V_{\phi SUB}$ | 23.0 | 24.0 | 25.0 | Vp-p | 5 | |

*1 Input the reset gate clock without applying a DC bias. In addition, the reset gate clock can also be driven with the following specifications.

| Item | Symbol | Min. | Typ. | Max. | Unit | Waveform diagram | Remarks |
|--------------------------|---------------|------|------|------|------|------------------|---------|
| Reset gate clock voltage | V_{RGL} | -0.2 | 0 | 0.2 | V | 4 | |
| | $V_{\phi RG}$ | 8.5 | 9.0 | 9.5 | Vp-p | 4 | |

Clock Equivalent Circuit Constant

| Item | Symbol | Min. | Typ. | Max. | Unit | Remarks |
|---|----------------------------|------|------|------|---------------|---------|
| Capacitance between vertical transfer clock and GND | $C\phi_{V1}, C\phi_{V3}$ | | 1800 | | μF | |
| | $C\phi_{V2}, C\phi_{V4}$ | | 2200 | | μF | |
| Capacitance between vertical transfer clocks | $C\phi_{V12}, C\phi_{V34}$ | | 450 | | μF | |
| | $C\phi_{V23}, C\phi_{V41}$ | | 270 | | μF | |
| Capacitance between horizontal transfer clock and GND | $C\phi_{H1}$ | | 64 | | μF | |
| | $C\phi_{H2}$ | | 62 | | μF | |
| Capacitance between horizontal transfer clocks | $C\phi_{HH}$ | | 47 | | μF | |
| Capacitance between reset gate clock and GND | $C\phi_{RG}$ | | 8 | | μF | |
| Capacitance between substrate clock and GND | $C\phi_{SUB}$ | | 400 | | μF | |
| Vertical transfer clock series resistor | R_1, R_2, R_3, R_4 | | 68 | | Ω | |
| Vertical transfer clock ground resistor | R_{GND} | | 15 | | Ω | |

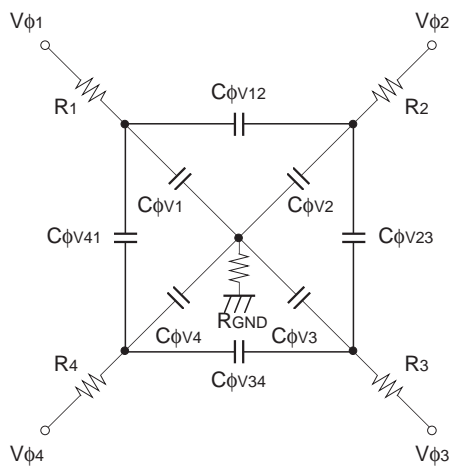

Vertical transfer clock equivalent circuit

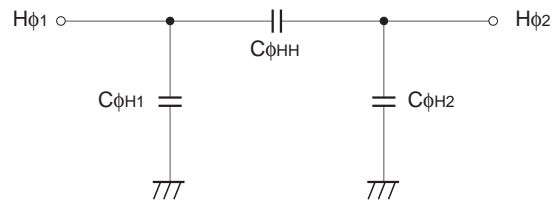

Horizontal transfer clock equivalent circuit

Drive Clock Waveform Conditions

(1) Readout clock waveform

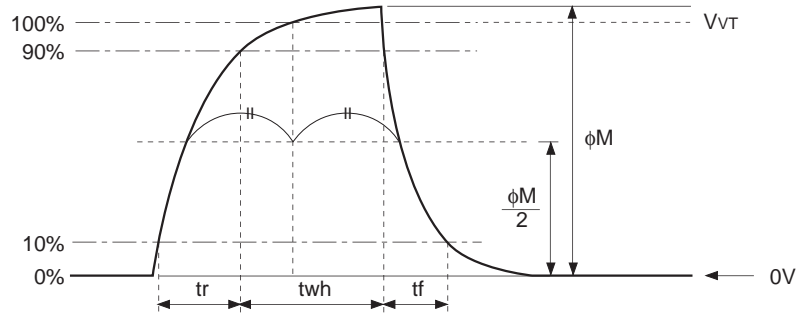

(2) Vertical transfer clock waveform

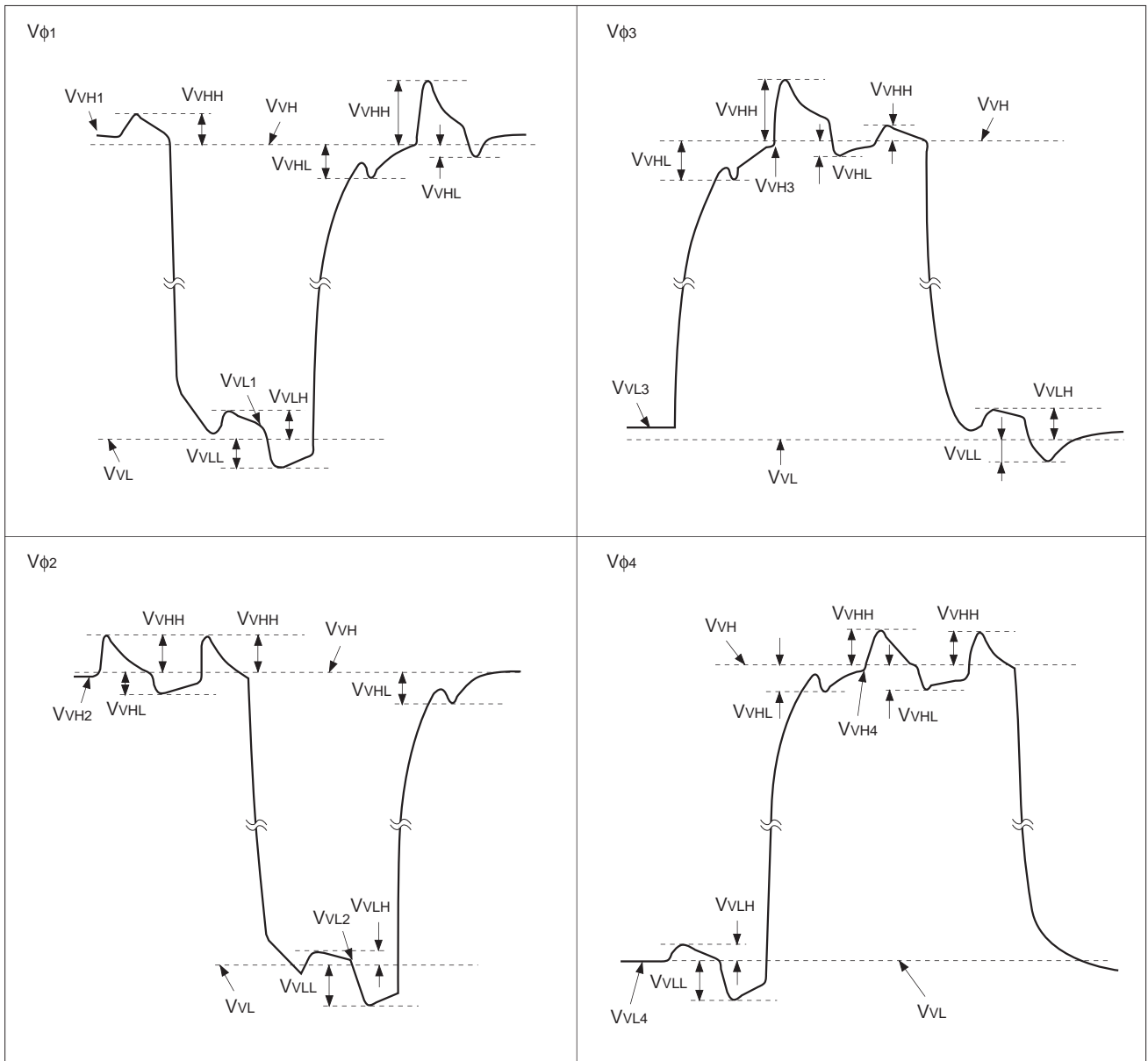

$$V_{VH} = (V_{VH1} + V_{VH2})/2$$

$$V_{VL} = (V_{VL3} + V_{VL4})/2$$

$$V_{\phi v} = V_{vHn} - V_{vLn} \quad (n = 1 \text{ to } 4)$$

(3) Horizontal transfer clock waveform

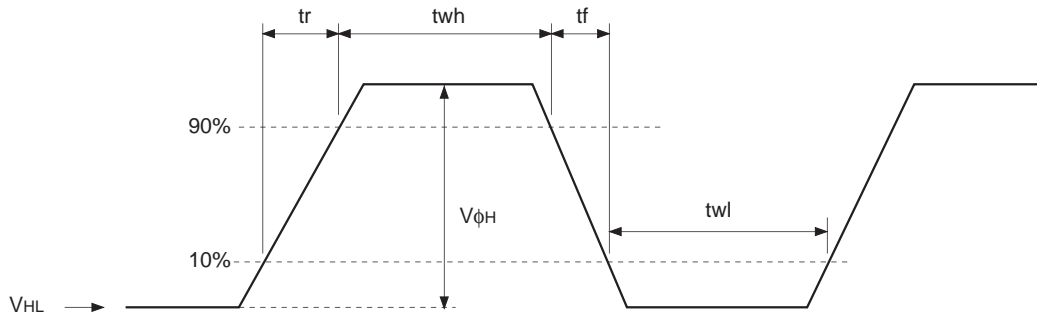

(4) Reset gate clock waveform

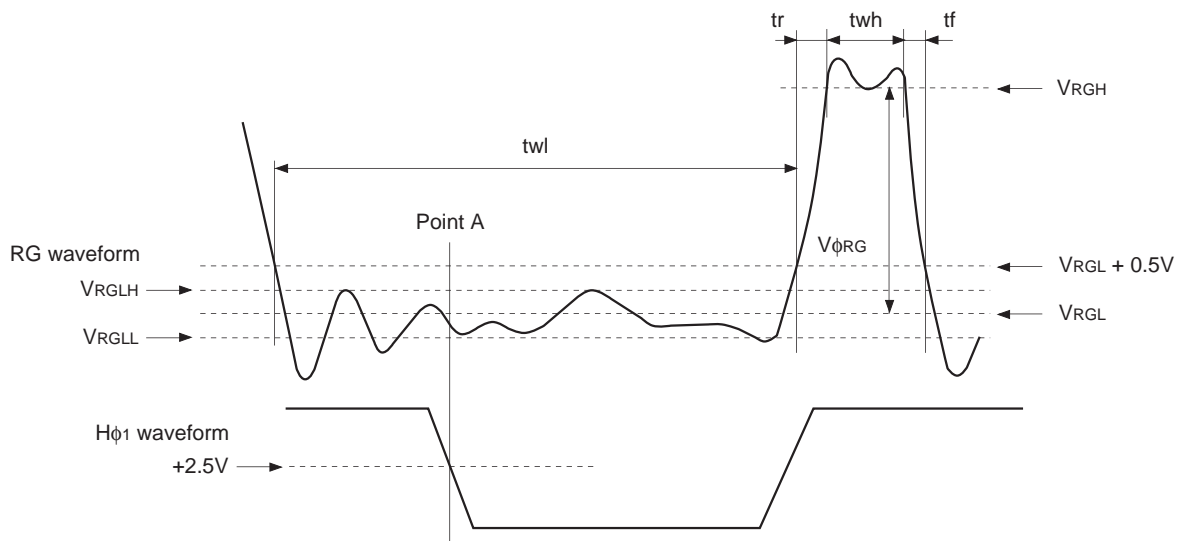

V_{RGLH} is the maximum value and V_{RGLL} is the minimum value of the coupling waveform during the period from Point A in the above diagram until the rising edge of RG. In addition, V_{RGL} is the average value of V_{RGLH} and V_{RGLL} .

$$V_{RGL} = (V_{RGLH} + V_{RGLL})/2$$

Assuming V_{RGH} is the minimum value during the period t_{wh} , then:

$$V_{\phi RG} = V_{RGH} - V_{RGL}$$

(5) Substrate clock waveform

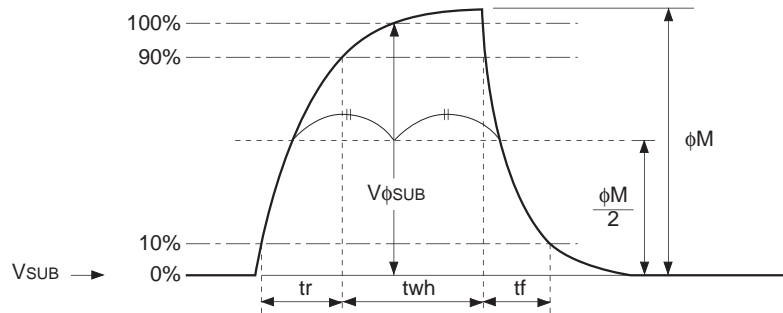

Clock Switching Characteristics

| Item | Symbol | twh | | | twl | | | tr | | | tf | | | Unit | Remarks |
|---------------------------|--|--------------|------|------|------|------|------|------|------|------|------|------|------|---------------|---------------------|
| | | Min. | Typ. | Max. | Min. | Typ. | Max. | Min. | Typ. | Max. | Min. | Typ. | Max. | | |
| Readout clock | V_T | 2.3 | 2.5 | | | | | 0.5 | | | 0.5 | | | μs | During readout |
| Vertical transfer clock | $V_{\phi 1}, V_{\phi 2}, V_{\phi 3}, V_{\phi 4}$ | | | | | | | | | | 15 | | 250 | ns | *1 |
| Horizontal transfer clock | During imaging | | 20 | | | 20 | | | 15 | 19 | | 15 | 19 | ns | *2 |
| | During parallel-serial conversion | $H_{\phi 1}$ | | 5.38 | | | | | 0.01 | | | 0.01 | | μs | |
| | | $H_{\phi 2}$ | | | | 5.38 | | | 0.01 | | | 0.01 | | μs | |
| Reset gate clock | ϕ_{RG} | 11 | 13 | | | 51 | | | 3 | | | 3 | | ns | |
| Substrate clock | ϕ_{SUB} | 1.5 | 1.8 | | | | | | | 0.5 | | | 0.5 | μs | During drain charge |

*1 When vertical transfer clock driver CXD1267AN is used.

*2 $t_f \geq t_r - 2\text{ns}$.

| Item | Symbol | two | | | Unit | Remarks |
|---------------------------|--------------------------|------|------|------|------|---------|
| | | Min. | Typ. | Max. | | |
| Horizontal transfer clock | $H_{\phi 1}, H_{\phi 2}$ | 16 | 20 | | ns | *3 |

*3 The overlap period for twh and twl of horizontal transfer clocks $H_{\phi 1}$ and $H_{\phi 2}$ is two.

Image Sensor Characteristics

(Ta = 25°C)

| Item | Symbol | Min. | Typ. | Max. | Unit | Measurement method | Remarks |
|--|--------------|------|---------|---------|------|--------------------|---------------|
| Sensitivity | S | 550 | 660 | | mV | 1 | |
| Saturation signal | Ysat | 720 | | | mV | 2 | Ta = 60°C |
| Smear | Sm | | 0.00032 | 0.00056 | % | 3 | |
| Video signal shading | SHy | | | 20 | % | 4 | Zone 0 and I |
| | | | | 25 | % | 4 | Zone 0 to II' |
| Uniformity between video signal channels | ΔSr | | | 10 | % | 5 | |
| | ΔSb | | | 10 | % | 5 | |
| Dark signal | Ydt | | | 2 | mV | 6 | Ta = 60°C |
| Dark signal shading | ΔYdt | | | 1 | mV | 7 | Ta = 60°C |
| Flicker Y | Fy | | | 2 | % | 8 | |
| Flicker R-Y | Fcr | | | 5 | % | 8 | |
| Flicker B-Y | Fcb | | | 5 | % | 8 | |
| Line crawl R | Lcr | | | 3 | % | 9 | |
| Line crawl G | Lcg | | | 3 | % | 9 | |
| Line crawl B | Lcb | | | 3 | % | 9 | |
| Line crawl W | Lcw | | | 3 | % | 9 | |
| Lag | Lag | | | 0.5 | % | 10 | |

Zone Definition of Video Signal Shading

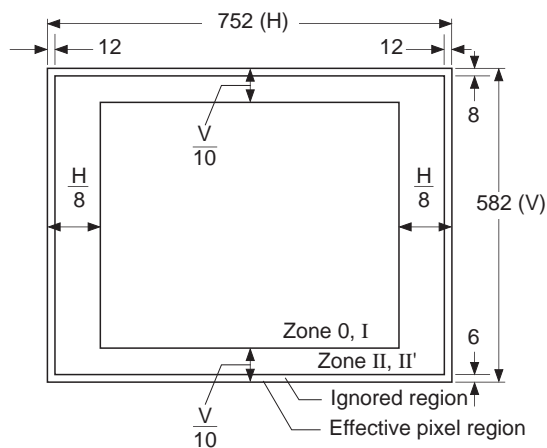

Measurement System

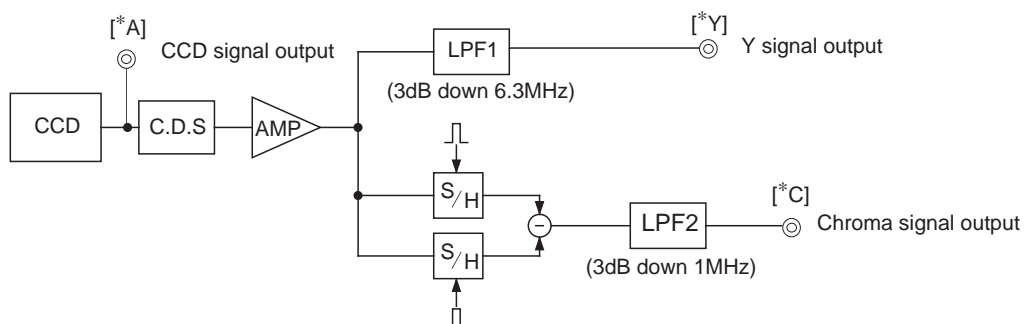

Note) Adjust the amplifier gain so that the gain between [*A] and [*Y], and between [*A] and [*C] equals 1.

Image Sensor Characteristics Measurement Method

◎ **Measurement conditions**

- 1) In the following measurements, the device drive conditions are at the typical values of the bias and clock voltage conditions. (when used with substrate bias external adjustment, set the substrate voltage to the value indicated on the device.)
- 2) In the following measurements, spot blemishes are excluded and, unless otherwise specified, the optical black level (OB) is used as the reference for the signal output, which is taken as the value of Y signal output or chroma signal output of the measurement system.

◎ **Color coding of this image sensor & Composition of luminance (Y) and chroma (color difference) signals**

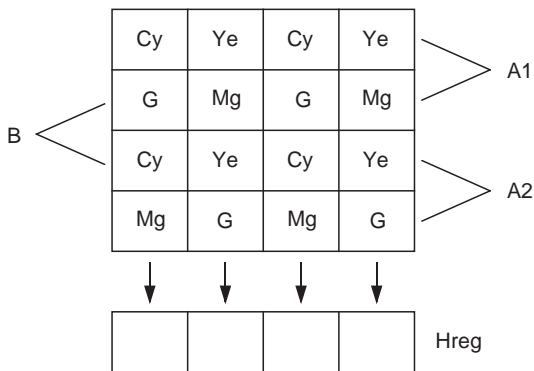

Color Coding Diagram

As shown in the left figure, fields are read out. The charge is mixed by pairs such as A1 and A2 in the A field. (pairs such as B in the B field)

As a result, the sequence of charges output as signals from the horizontal shift register (Hreg) is, for line A1, (G + Cy), (Mg + Ye), (G + Cy), and (Mg + Ye).

These signals are processed to form the Y signal and chroma (color difference) signal. The Y signal is formed by adding adjacent signals, and the chroma signal is formed by subtracting adjacent signals. In other words, the approximation:

$$Y = \{(G + Cy) + (Mg + Ye)\} \times 1/2$$

$$= 1/2 \{2B + 3G + 2R\}$$

is used for the Y signal, and the approximation:

$$R - Y = \{(Mg + Ye) - (G + Cy)\}$$

$$= \{2R - G\}$$

is used for the chroma (color difference) signal. For line A2, the signals output from Hreg in sequence are

$$(Mg + Cy), (G + Ye), (Mg + Cy), (G + Ye).$$

The Y signal is formed from these signals as follows:

$$Y = \{(G + Ye) + (Mg + Cy)\} \times 1/2$$

$$= 1/2 \{2B + 3G + 2R\}$$

This is balanced since it is formed in the same way as for line A1.

In a like manner, the chroma (color difference) signal is approximated as follows:

$$-(B - Y) = \{(G + Ye) - (Mg + Cy)\}$$

$$= -\{2B - G\}$$

In other words, the chroma signal can be retrieved according to the sequence of lines from R - Y and - (B - Y) in alternation. This is also true for the B field.

◎ Definition of standard imaging conditions

1) Standard imaging condition I:

Use a pattern box (luminance 706cd/m², color temperature of 3200K halogen source) as a subject. (Pattern for evaluation is not applicable.) Use a testing standard lens with CM500S (t = 1.0mm) as an IR cut filter and image at F5.6. The luminous intensity to the sensor receiving surface at this point is defined as the standard sensitivity testing luminous intensity.

2) Standard imaging condition II:

Image a light source (color temperature of 3200K) with a uniformity of brightness within 2% at all angles. Use a testing standard lens with CM500S (t = 1.0mm) as an IR cut filter. The luminous intensity is adjusted to the value indicated in each testing item by the lens diaphragm.

1. Sensitivity

Set to standard imaging condition I. After selecting the electronic shutter mode with a shutter speed of 1/250s, measure the Y signal (Y_s) at the center of the screen and substitute the value into the following formula.

$$S = Y_s \times \frac{250}{50} \text{ [mV]}$$

2. Saturation signal

Set to standard imaging condition II. After adjusting the luminous intensity to 10 times the intensity with average value of the Y signal output, 200mV, measure the minimum value of the Y signal.

3. Smear

Set to standard imaging condition II. With the lens diaphragm at F5.6 to F8, adjust the luminous intensity to 500 times the intensity with average value of the Y signal output, 200mV. When the readout clock is stopped and the charge drain is executed by the electronic shutter at the respective H blankings, measure the maximum value Y_{Sm} [mV] of the Y signal output and substitute the value into the following formula.

$$S_m = \frac{Y_{Sm}}{200} \times \frac{1}{500} \times \frac{1}{10} \times 100 \text{ [%]} \text{ (1/10V method conversion value)}$$

4. Video signal shading

Set to standard imaging condition II. With the lens diaphragm at F5.6 to F8, adjust the luminous intensity so that the average value of the Y signal output is 200mV. Then measure the maximum (Y_{max} [mV]) and minimum (Y_{min} [mV]) values of the Y signal and substitute the values into the following formula.

$$S_{Hy} = (Y_{max} - Y_{min})/200 \times 100 \text{ [%]}$$

5. Uniformity between video signal channels

Set to standard imaging condition II. Adjust the luminous intensity so that the average value of the Y signal output is 200mV, and then measure the maximum (C_{rmax}, C_{bmax} [mV]) and minimum (C_{rmin}, C_{bmin} [mV]) values of the R – Y and B – Y channels of the chroma signal and substitute the values into the following formula.

$$\Delta S_r = | (C_{rmax} - C_{rmin})/200 | \times 100 \text{ [%]}$$

$$\Delta S_b = | (C_{bmax} - C_{bmin})/200 | \times 100 \text{ [%]}$$

6. Dark signal

Measure the average value of the Y signal output (Y_{dt} [mV]) with the device ambient temperature 60°C and the device in the light-obstructed state, using the horizontal idle transfer level as a reference.

7. Dark signal shading

After measuring 6, measure the maximum (Y_{dmax} [mV]) and minimum (Y_{dmin} [mV]) values of the dark signal output and substitute the values into the following formula.

$$\Delta Y_{dt} = Y_{dmax} - Y_{dmin} \text{ [mV]}$$

8. Flicker

1) F_y

Set to standard imaging condition II. Adjust the luminous intensity so that the average value of the Y signal output is 200mV, and then measure the difference in the signal level between fields (ΔY_f [mV]). Then substitute the value into the following formula.

$$F_y = (\Delta Y_f / 200) \times 100 \text{ [%]}$$

2) F_{cr} , F_{cb}

Set to standard imaging condition II. Adjust the luminous intensity so that the average value of the Y signal output is 200mV, insert an R or B filter, and then measure both the difference in the signal level between fields of the chroma signal (ΔC_r , ΔC_b) as well as the average value of the chroma signal output (C_{Ar} , C_{Ab}). Substitute the values into the following formula.

$$F_{ci} = (\Delta C_i / C_{Ai}) \times 100 \text{ [%]} \text{ (i = r, b)}$$

9. Line crawls

Set to standard imaging condition II. Adjust the luminous intensity so that the average value of the Y signal output is 200mV, and then insert a white subject and R, G, and B filters and measure the difference between Y signal lines for the same field (ΔY_{lw} , ΔY_{lr} , ΔY_{lg} , ΔY_{lb} [mV]). Substitute the values into the following formula.

$$L_{ci} = (\Delta Y_{li} / 200) \times 100 \text{ [%]} \text{ (i = w, r, g, b)}$$

10. Lag

Adjust the Y signal output value generated by strobe light to 200mV. After setting the strobe light so that it strobes with the following timing, measure the residual signal (Y_{lag}). Substitute the value into the following formula.

$$Lag = (Y_{lag} / 200) \times 100 \text{ [%]}$$

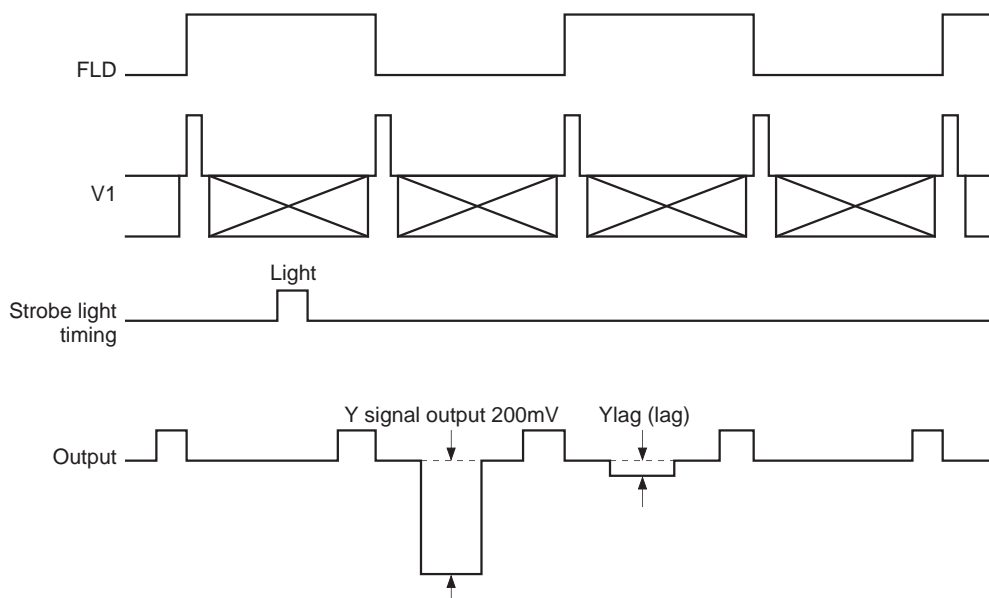

Drive Circuit 1 (substrate bias internal generation mode)

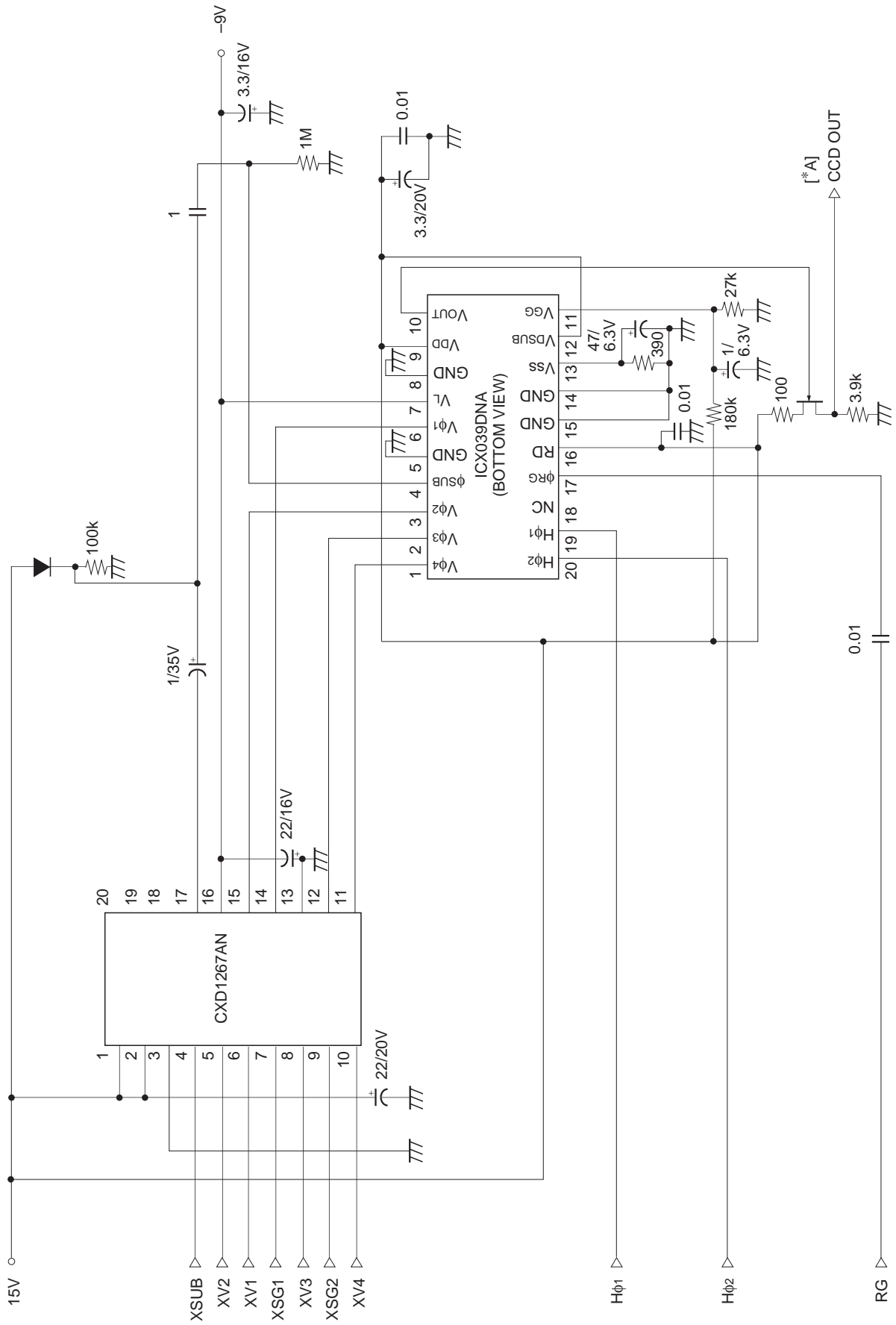

Drive Circuit 2 (substrate bias external adjustment mode)

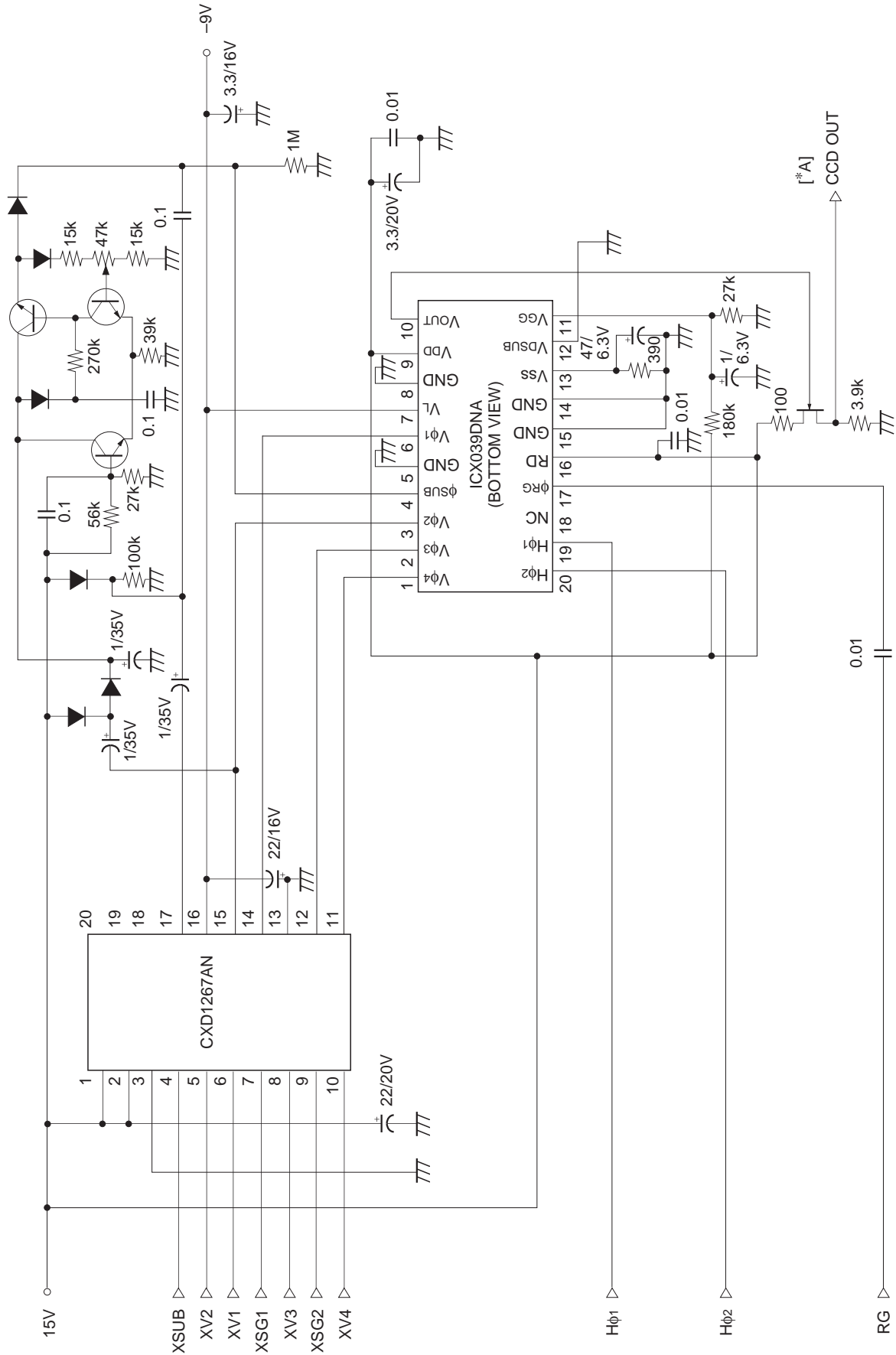

Spectral Sensitivity Characteristics
 (Excludes lens characteristics and light source characteristics)

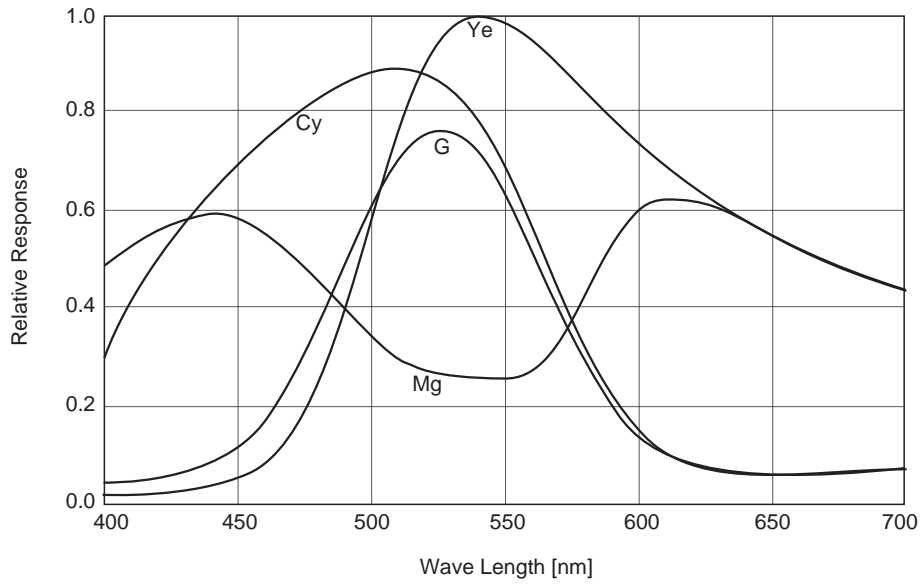

Sensor Readout Clock Timing Chart

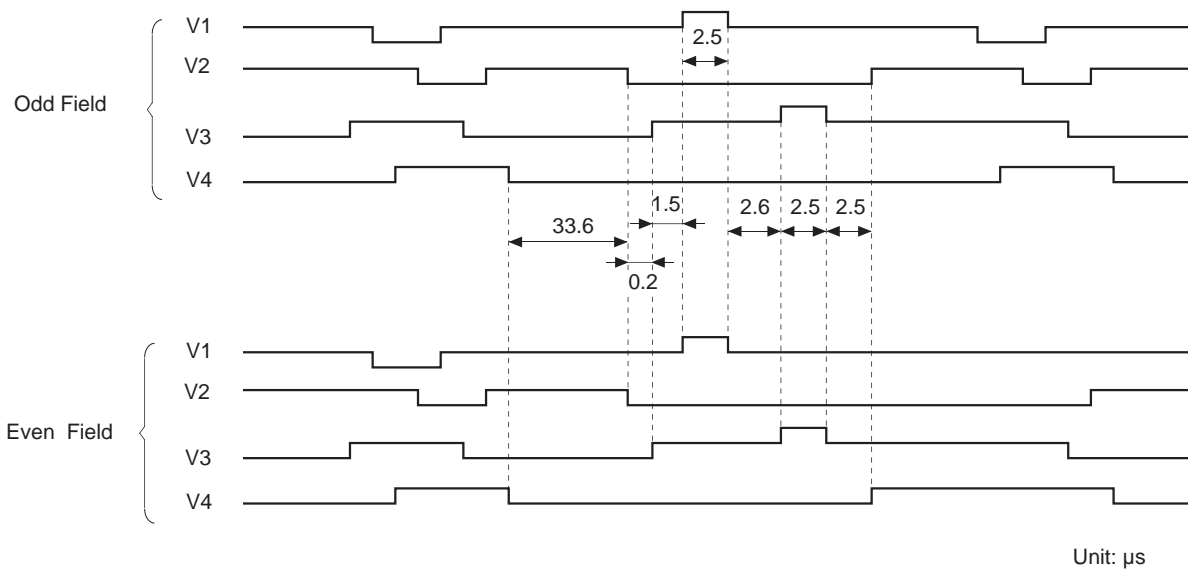

Drive Timing Chart (Vertical Sync)

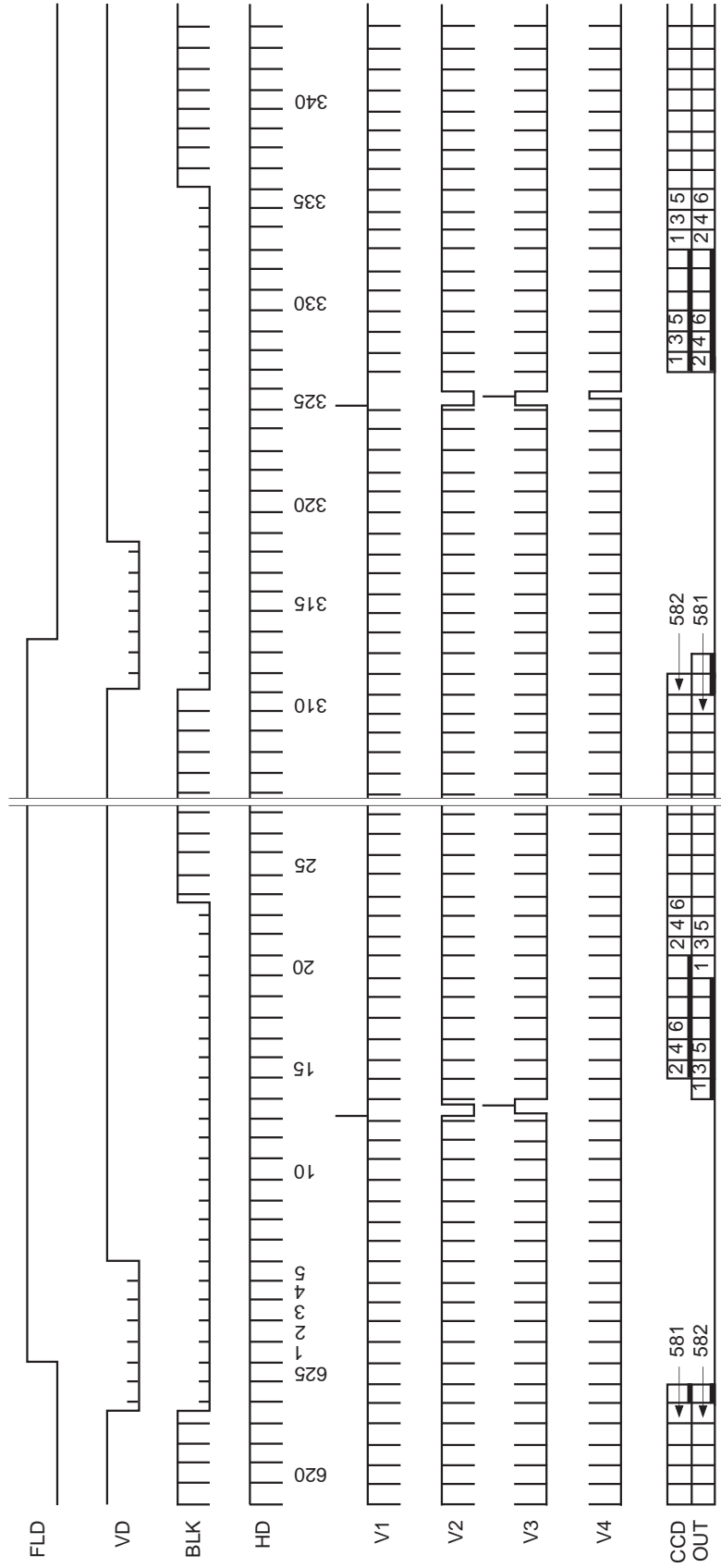

Drive Timing Chart (Horizontal Sync)

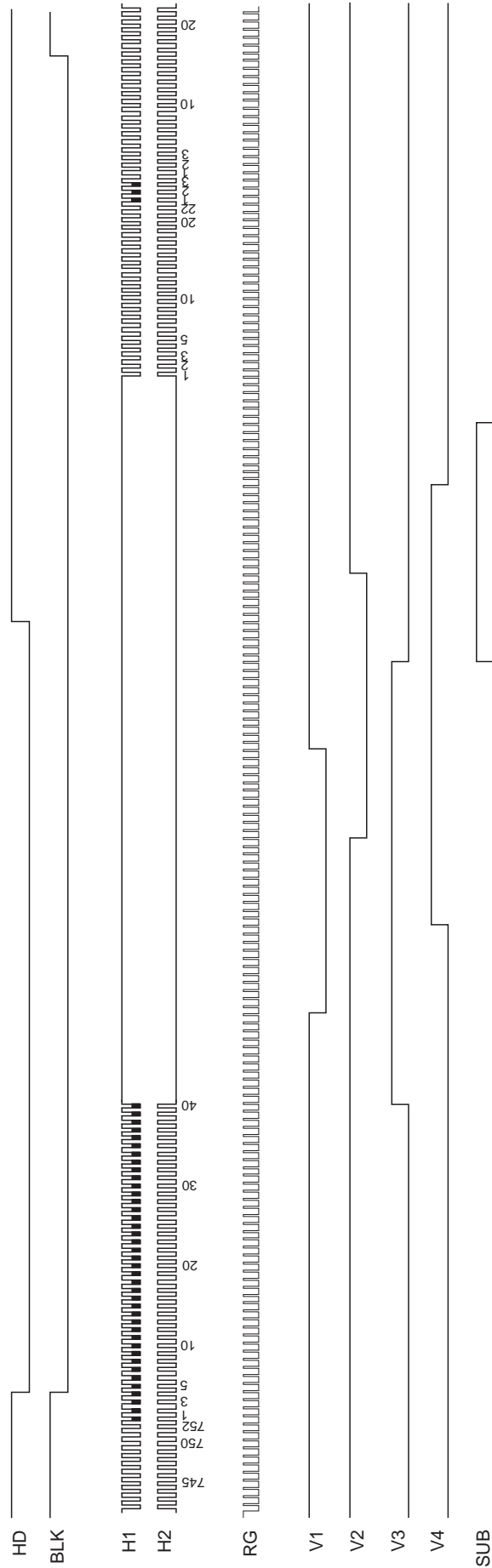

Notes on Handling

1) Static charge prevention

CCD image sensors are easily damaged by static discharge. Before handling be sure to take the following protective measures.

- Either handle bare handed or use non-chargeable gloves, clothes or material.
Also use conductive shoes.
- When handling directly use an earth band.
- Install a conductive mat on the floor or working table to prevent the generation of static electricity.
- Ionized air is recommended for discharge when handling CCD image sensor.
- For the shipment of mounted substrates, use boxes treated for the prevention of static charges.

2) Soldering

- Make sure the package temperature does not exceed 80°C.
- Solder dipping in a mounting furnace causes damage to the glass and other defects. Use a ground 30W soldering iron and solder each pin in less than 2 seconds. For repairs and remount, cool sufficiently.
- To dismount an image sensor, do not use a solder suction equipment. When using an electric desoldering tool, use a thermal controller of the zero cross On/Off type and connect it to ground.

3) Dust and dirt protection

Image sensors are packed and delivered by taking care of protecting its glass plates from harmful dust and dirt. Clean glass plates with the following operation as required, and use them.

- Perform all assembly operations in a clean room (class 1000 or less).
- Do not either touch glass plates by hand or have any object come in contact with glass surfaces. Should dirt stick to a glass surface, blow it off with an air blower. (For dirt stuck through static electricity ionized air is recommended.)
- Clean with a cotton bud and ethyl alcohol if the grease stained. Be careful not to scratch the glass.
- Keep in a case to protect from dust and dirt. To prevent dew condensation, preheat or precool when moving to a room with great temperature differences.
- When a protective tape is applied before shipping, just before use remove the tape applied for electrostatic protection. Do not reuse the tape.

4) Installing (attaching)

- Remain within the following limits when applying a static load to the package. Do not apply any load more than 0.7mm inside the outer perimeter of the glass portion, and do not apply any load or impact to limited portions. (This may cause cracks in the package.)

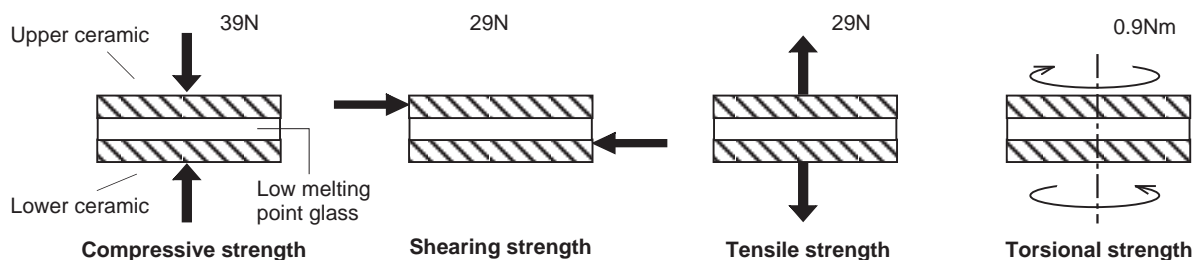

- If a load is applied to the entire surface by a hard component, bending stress may be generated and the package may fracture, etc., depending on the flatness of the ceramic portions. Therefore, for installation, use either an elastic load, such as a spring plate, or an adhesive.

- c) The adhesive may cause the marking on the rear surface to disappear, especially in case the regulated voltage value is indicated on the rear surface. Therefore, the adhesive should not be applied to this area, and indicated values should be transferred to other locations as a precaution.
- d) The upper and lower ceramic are joined by low melting point glass. Therefore, care should be taken not to perform the following actions as this may cause cracks.
- Applying repeated bending stress to the outer leads.
 - Heating the outer leads for an extended period with a soldering iron.
 - Rapidly cooling or heating the package.
 - Applying any load or impact to a limited portion of the low melting point glass using tweezers or other sharp tools.
 - Prying at the upper or lower ceramic using the low melting point glass as a fulcrum.
- Note that the same cautions also apply when removing soldered products from boards.
- e) Acrylate anaerobic adhesives are generally used to attach CCD image sensors. In addition, cyanoacrylate instantaneous adhesives are sometimes used jointly with acrylate anaerobic adhesives. (reference)

5) Others

- a) Do not expose to strong light (sun rays) for long periods, color filters will be discolored. When high luminance objects are imaged with the exposure level control by electronic-iris, the luminance of the image-plane may become excessive and discolor of the color filter will possibly be accelerated. In such a case, it is advisable that taking-lens with the automatic-iris and closing of the shutter during the power-off mode should be properly arranged. For continuous using under cruel condition exceeding the normal using condition, consult our company.
- b) Exposure to high temperature or humidity will affect the characteristics. Accordingly avoid storage or usage in such conditions.

Package Outline Unit: mm

20pin DIP (600mil)

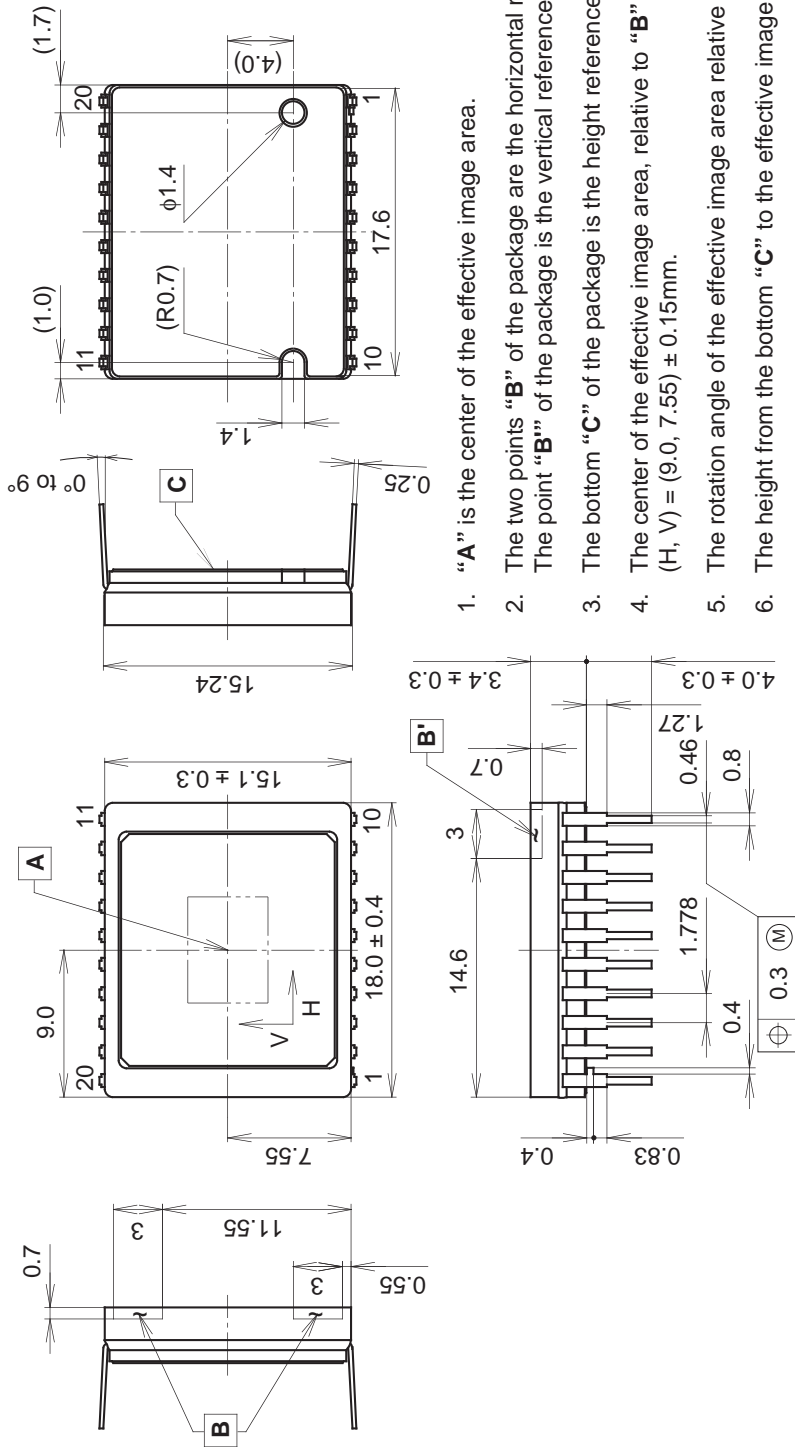

1. "A" is the center of the effective image area.
2. The two points "B" of the package are the horizontal reference. The point "B'" of the package is the vertical reference.
3. The bottom "C" of the package is the height reference.
4. The center of the effective image area, relative to "B" and "B'" is (H, V) = (9.0, 7.55) ± 0.15mm.
5. The rotation angle of the effective image area relative to H and V is ± 1°.
6. The height from the bottom "C" to the effective image area is 1.41 ± 0.15mm.
7. The tilt of the effective image area relative to the bottom "C" is less than 60µm.
8. The thickness of the cover glass is 0.75mm, and the refractive index is 1.5.
9. The notch and the hole on the bottom must not be used for reference of fixing.

PACKAGE STRUCTURE

| | |
|------------------|-------------|
| PACKAGE MATERIAL | Cer-DIP |
| LEAD TREATMENT | TIN PLATING |
| LEAD MATERIAL | 42 ALLOY |
| PACKAGE WEIGHT | 2.6g |