



# AAT4682

## Dual Electronic Resettable Switches

SmartSwitch™

### General Description

The AAT4682 Dual Electronic Resettable fuse is part of the AnalogicTech Application Specific Power MOSFET (ASPM™) line of products. It has two 1A current limited P-channel MOSFET power devices that remain fully enhanced as long as the input power supply is above an under voltage lockout threshold, and the load is below the current limit setting. If the load increases above the current limit setting, as is the case during a short circuit, the MOSFET effectively becomes a constant current source equal to the current limit. If the current limit condition persists long enough to heat the MOSFET to an extreme temperature, both devices will thermal cycle off and on until the current limit condition is removed. Independent open drain FAULT flags signal an over current or over temperature condition. Quiescent current typically is a low 10µA.

The AAT4682 is available in a 6 pin SOT-23, specified over a -40 to 85°C temperature range.

### Features

- Dual P-Channel MOSFETS
- 500mA steady state load current
- 600mA minimum current limit trip point
- Low quiescent current, typically 10µA.
- Over temperature protection
- Fast transient response:
  - < 1µs response to short circuit
- 400mΩ typical R<sub>DS(ON)</sub>
- Undervoltage Lockout
- Temp range -40 to 85°C
- FAULT flag with 2ms blanking
- 6-pin SOT23 package

### Applications

- USB ports
- Peripheral ports
- Desktop PCs
- Cell phone ports

Preliminary Information

### Typical Application

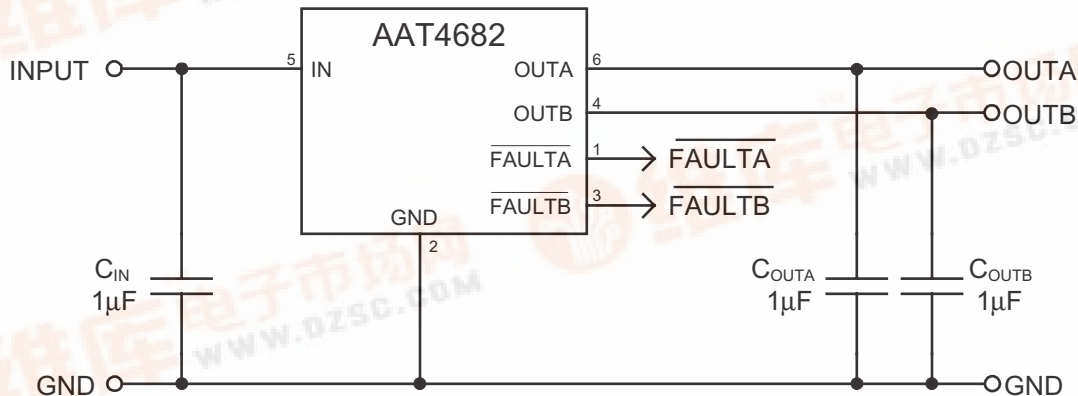

## Pin Descriptions

Pin #	Symbol	Function
1	$\overline{\text{FAULTA}}$	Channel A open drain output signals over-current and over-temperature condition
2	GND	Ground connection
3	$\overline{\text{FAULTB}}$	Channel B open drain output signals over-current and over-temperature condition
4	OUTB	Channel B P-channel MOSFET drain
5	IN	Channel A and Channel B P-channel MOSFET sources
6	OUTA	Channel A P-channel MOSFET drain

## Pin Configuration

SOT23-6

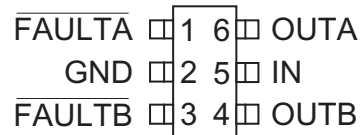

### Absolute Maximum Ratings ( $T_A=25^\circ\text{C}$ unless otherwise noted)

Symbol	Description	Value	Units
$V_{IN}$	IN to GND	-0.3 to 6	V
$V_{OUT}$	OUTA or OUTB to GND	-0.3 to 6	V
$V_{FLG}$	FAULTA or FAULTB to GND	-0.3 to 6	V
$I_{OUT}$	Output Current	Internally Limited	A
$T_J$	Operating Junction Temperature Range	-40 to 150	$^\circ\text{C}$
$V_{ESD}$	ESD Rating <sup>1</sup> - HBM	5000	V
$T_{LEAD}$	Maximum Soldering Temperature (at Leads)	300	$^\circ\text{C}$

Note: Stresses above those listed in Absolute Maximum Ratings may cause permanent damage to the device. Functional operation at conditions other than the operating conditions specified is not implied. Only one Absolute Maximum rating should be applied at any one time.

Note 1: Human body model is a 100pF capacitor discharged through a 1.5k $\Omega$  resistor into each pin.

### Thermal Characteristics

Symbol	Description	Value	Units
$\Theta_{JA}$	Maximum Thermal Resistance <sup>2</sup>	150	$^\circ\text{C}/\text{W}$
$P_D$	Maximum Power Dissipation <sup>2</sup>	667	mW

Note 2: Mounted on a demo board.

### Electrical Characteristics ( $V_{IN} = 5\text{V}$ , $T_A = -40$ to $85^\circ\text{C}$ unless otherwise noted. Typical values are at $T_A=25^\circ\text{C}$ ; bold values designate full temperature range)

Symbol	Description	Conditions	Min	Typ	Max	Units
$V_{IN}$	Operation Voltage		<b>1.8</b>		<b>5.5</b>	V
$I_Q$	Quiescent Current	$V_{IN} = 5\text{V}$ , $I_{OUT} = 0$		10	<b>20</b>	$\mu\text{A}$
$V_{UVLO}$	Undervoltage Lockout	$V_{IN}$ falling		1.5		V
$V_{UVLO(hys)}$	Undervoltage Lockout Hysteresis			0.3		V
$R_{DS(ON)}$	On-Resistance	$V_{IN} = 5.0\text{V}$ , $T_A = 25^\circ\text{C}$		400	500	m $\Omega$
		$V_{IN} = 3.0\text{V}$ , $T_A = 25^\circ\text{C}$		525	650	
$I_{LIM}$	Current Limit	OUT < IN - 0.5V	0.6	0.875	1.25	A
$t_{RESP}$	Current Loop Response	$V_{IN} = 5\text{V}$		500		ns
$V_{FAULTLOW}$	FAULT Logic Output Low	$I_{SINK} = 1\text{mA}$			<b>0.4</b>	V
$I_{SINK}$	FAULT Logic Output High Leakage Current	$V_{FAULT} = 5.5\text{V}$		0.5	<b>1</b>	$\mu\text{A}$
$T_{blank}$	FAULT Blanking Time			2		ms
$T_{SD}$	Over-temperature threshold			125		$^\circ\text{C}$

### Typical Characteristics

(Unless otherwise noted,  $V_{IN} = 5V$ ,  $T_A = 25^\circ C$ )

**Quiescent Current vs. Temperature**

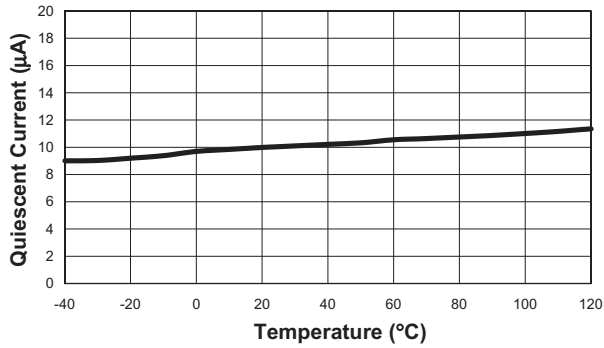

**Quiescent Current vs. Input Voltage**

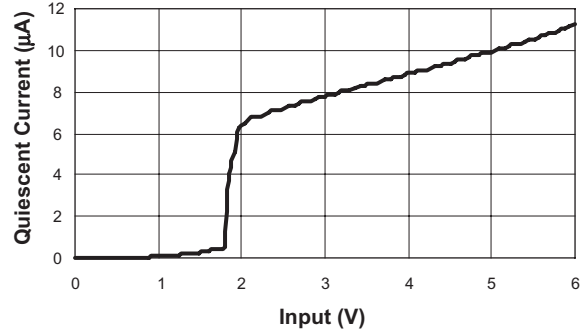

**Current Limit vs. Output Voltage**

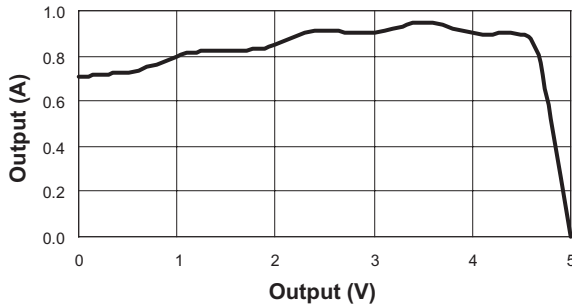

**$R_{DS(ON)}$  vs. Temperature**

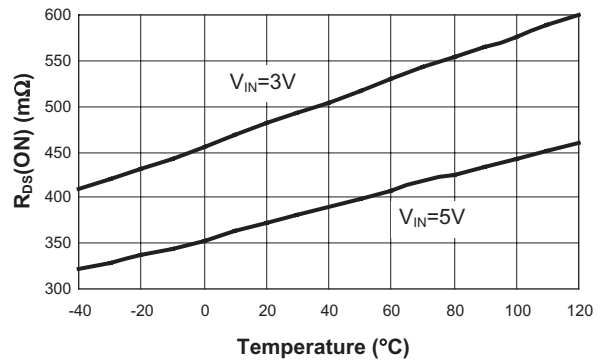

**Short Circuit Through 0.3Ω**

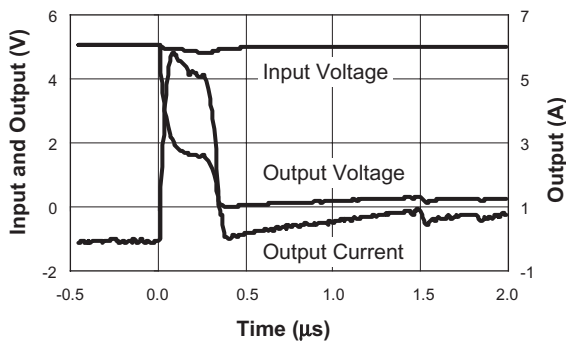

**Short Circuit Through 0.6Ω**

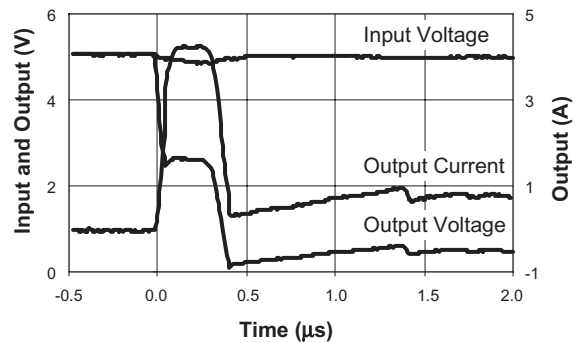

### Typical Characteristics

(Unless otherwise noted,  $V_{IN} = 5V$ ,  $T_A = 25^\circ C$ )

**Thermal Shutdown Response**

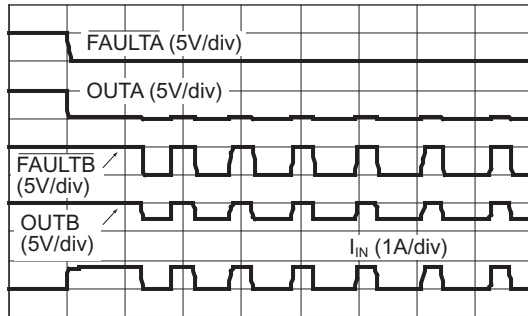

50ms/div

**Fault Delay**

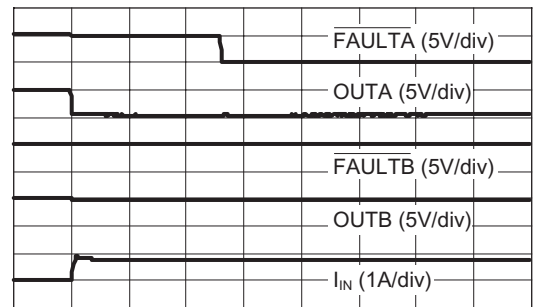

500µs/div

### Functional Block Diagram

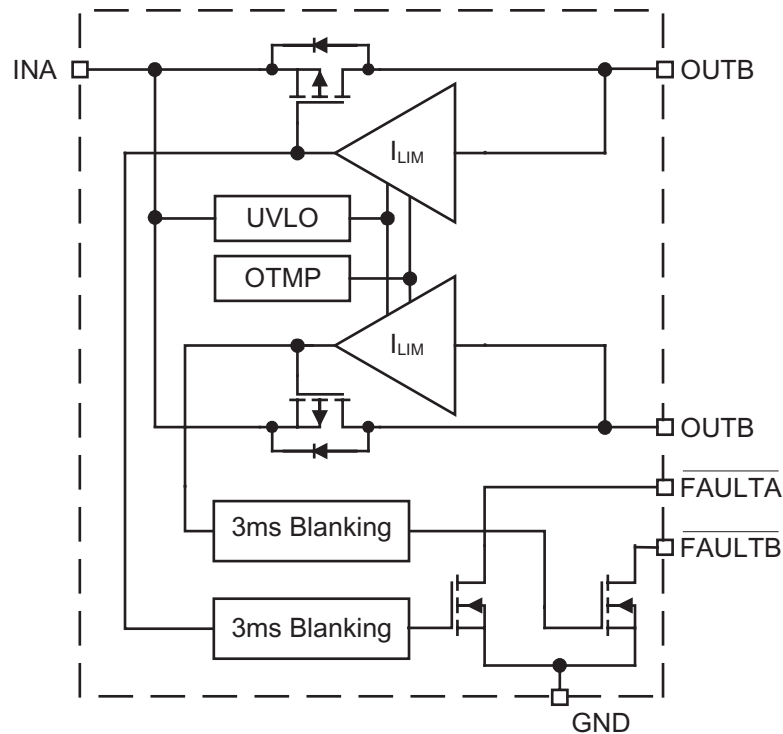

### Functional Description

The AAT4682 is a dual channel electronic resettable fuse that protects against short circuit conditions by current limiting to a preset level. A patented fast acting current limit loop limits load current in a fraction of a microsecond, and instantly resets back to a low impedance state once the short circuit condition is removed. A current limit condition is reported by the open drain FAULT output after a two millisecond blanking interval. The blanking prevents false reporting during the charging of a capacitive load, which typically occurs when a load is connected. The AAT4682 is internally protected from thermal damage by an over temperature detection circuit. If the die temperature reaches the internal thermal limit, both power devices are switched off until the die temperature cools to a level below the thermal limit threshold. The device

will thermal cycle indefinitely until the over current condition is removed. Due to the high thermal conductivity of silicon and the size of the die, the temperature across the die is relatively uniform at high temperatures, and therefore, as a precaution, both power devices are switched off when the thermal threshold is reached. The AAT4682 operates with input voltages ranging from 1.8V to 5.5V which, along with its extremely low operating current, makes it ideal for battery-powered applications. In cases where the input voltage drops below 1.8V, the AAT4682 internal MOSFETS are protected from entering the saturated region of operation by being automatically shut down by an undervoltage lockout circuit.

The AAT4682 is ideally suited for protection of peripheral ports such as USB, RS232 and parallel ports.

## Applications Information

### Input Capacitor

The input capacitor protects the power supply from current transients generated by the loads attached to the AAT4682. If a short circuit is suddenly applied to a AAT4682 output, there is a 500 nanosecond long period during which a large current can flow before current limit circuitry activates. (See characteristic curve "Short Circuit Through 0.3Ω.") In this event, a properly sized input capacitor can dramatically reduce the voltage transient seen by the power supply and other circuitry upstream from the AAT4682.

C<sub>IN</sub> should be located as close to the device V<sub>IN</sub> pin as practically possible. Ceramic, tantalum or aluminum electrolytic capacitors may be selected for C<sub>IN</sub>. There is no specific capacitor ESR requirement for C<sub>IN</sub>. However, for higher current operation, ceramic capacitors are recommended for C<sub>IN</sub> due to their inherent capability over tantalum capacitors to withstand input current surges from low impedance sources such as batteries in portable devices.

### Output Capacitors

In order to insure stability while current limit is active, a small output capacitance of approximately 1μF is required at each output. No matter how big the output capacitor, output current is limited to the value set by the AAT4682 current limiting circuitry, allowing very large output capacitors to be used.

For example, USB ports are specified to have at least 120μF of capacitance down stream from their controlling power switch. The current limiting circuit will allow an output capacitance of 1000μF or more without disturbing the upstream power supply.

### Attaching Loads

Capacitive loads attached to the AAT4682 will charge at a rate no greater than the current limit setting.

### FAULT Outputs

FAULT flags are provided to alert a system if a AAT4682 load is not receiving sufficient voltage to operate properly. If current limit or over temperature circuits in any combination are active for more than approximately two milliseconds, the corresponding FAULT output is pulled to ground through approximately 100Ω. Removal of voltage or current transients of less than two milliseconds prevents capaci-

tive loads connected to the AAT4682 output from activating the FAULT flag when they are initially attached. Pull up resistances of 10kΩ to 100kΩ are recommended. Since the FAULT outputs are open drain terminals, they may be pulled up to any voltage rail less than the maximum operating voltage of 5.5V, allowing for level shifting between circuits.

### Thermal Considerations

Since the AAT4682 has internal current limit and over temperature protection, junction temperature is rarely a concern. However, if the application requires large currents in a hot environment, it is possible that temperature rather than current limit will be the dominant regulating condition. In these applications, the maximum combined current available without risk of an over temperature condition can be calculated. The maximum internal temperature while current limit is not active can be calculated using Equation 1.

$$T_{J(MAX)} = I_{MAX}^2 \times R_{DS(ON)(MAX)} \times R_{\theta JA} + T_A(MAX)$$

In Equation 1, I<sub>MAX</sub> is the maximum current required by the load. R<sub>DS(ON)(MAX)</sub> is the maximum rated R<sub>DS(ON)</sub> of the AAT4682 at high temperature. R<sub>θJA</sub> is the thermal resistance between the AAT4682 die and the board onto which it is mounted. T<sub>A</sub>(MAX) is the maximum temperature that the PCB under the AAT4682 would be if the AAT4682 were not dissipating power. Equation 1 can be rearranged to solve for I<sub>MAX</sub>; Equation 2.

$$I_{MAX} = \sqrt{\frac{T_{SD(MIN)} - T_A(MAX)}{R_{DS(ON)(MAX)} \times R_{\theta JA}}}$$

T<sub>SD(MIN)</sub> is the minimum temperature required to activate the AAT4682 over temperature protection. The typical over temperature threshold specification is 125°C, therefore 115°C is a safe minimum value to use.

For example, if an application is specified to operate in 50°C environments, the PCB operates at temperatures as high as 85°C. The application is sealed and its PCB is small, causing R<sub>θJA</sub> to be approximately 150°C/W. Using Equation 2,

$$I_{MAX} = \sqrt{\frac{115 - 85}{600 \times 150}} = 575\text{mA}$$

To prevent thermal limiting, the combined operating load current of each output in the application must be less than 575mA.

### Ordering Information

Package	Marking	Part Number	
		Bulk	Tape and Reel
SOT23-6		N/A	AAT4682IGU-T1

### Package Information

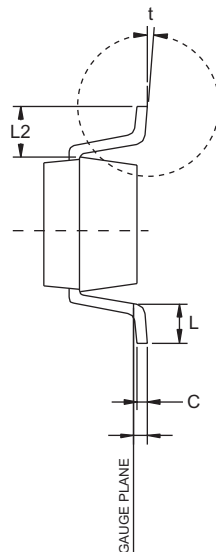
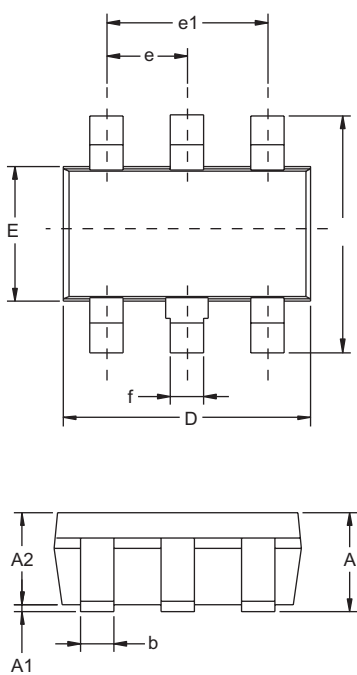

Dim	Millimeters		Inches	
	Min	Max	Min	Max
A	0.95	1.45	0.037	0.057
A1	0.05	0.15	0.002	0.006
A2	0.90	1.30	0.035	0.051
b	0.35	0.50	0.0137	0.019
c	0.08	0.20	0.0031	0.0078
D	2.84	3.00	0.1118	0.118
E	1.50	1.70	0.059	0.0669
E1	2.60	3.00	0.102	0.118
e	0.95 BSC		0.0374 BSC	
e1	1.90 BSC		0.0748 BSC	
f	0.50 BSC		0.0197 BSC	
L	0.23	0.40	0.009	0.016
L1	0.10 BSC		0.039 BSC	
L2	0.60 BSC		0.0236 BSC	
t	0°	10°	0°	10°