

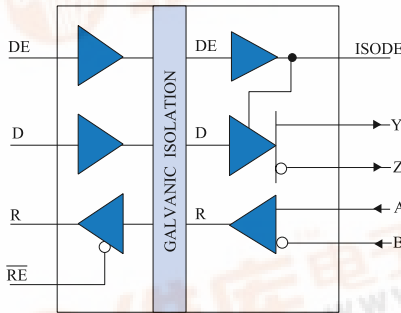

IL422-3V^{IsoLoop®}

Isolated 3Volt RS422/RS485 Interface

Functional Diagram



Features

- 3.3 V Input Supply Compatible
- 2500 V_{RMS} Isolation (1 min)
- 25 ns Propagation Delay
- 25 Mbaud Data Rate
- 1 ns Pulse Skew (typ)
- ±60 mA Driver Output Capability
- Thermal Shutdown Protection
- Meets or Exceeds EIA 422-B, EIA 485-A and ITU Recommendation V11
- -40°C to +85°C Temperature Range
- 16 Pin SOIC Package
- PROFIBUS International Component Recognition
- UL 1577 Approval Pending
- IEC 61010-1 Approval Pending

Function Table

V _{ID1} (Y-Z)	V _{ID2} (A-B)	DE	\overline{RE}	ISODE	R	D	MODE
X	≥ 0.2V	X	L	X	H	X	Receive
X	≤ -0.2V	X	L	X	L	X	Receive
-7<V _{ID1} <12	-7<V _{ID2} <12	X	H	X	Z	X	Receive/Drive
≥ 1.5	X	H	L	H	H	H	Drive
≤ -1.5	X	H	L	H	L	L	Drive
	Open	L	L	L	H	X	Receive

H= High Level, L= Low Level,
X= Irrelevant, Z= High Impedance

Ordering Information

Order as IL422-3V. If requesting tape and reel, please specify as IL422-3V TR.

Applications

Multi-point or Multi-drop Transmission on Long Bus Lines in Noisy Environments

Description

The IL422-3V is a galvanically isolated, high speed differential driver and receiver pair, designed for bidirectional data communication on balanced transmission lines. Isolation is achieved through patented* IsoLoop® technology. The IL422-3V is the first isolated RS-422 interface available in a standard 16 pin SOIC package, which meets the ANSI Standards EIA/TIA-422-B and RS485.

The IL422-3V has current limiting and thermal shutdown features to protect against output short circuits and bus contention situations where these may cause excessive power dissipation.

IsoLoop® is a registered trademark of NVE Corporation

* US Patent number 5,831,426; 6,300,617 and others



IL422-3V^{isoLoop®}

Absolute Maximum Ratings

Parameters	Symbol	Min.	Max.	Units
Storage Temperature	T_S	-65	150	°C
Ambient Operating Temperature	T_A	-40	85	°C
Voltage Range at A or B Bus Pins		-7	12	V
Supply Voltage ⁽¹⁾	V_{DD1}, V_{DD2}	-0.5	7	V
Digital Input Voltage		-0.5	5.5	V
Digital Output Voltage		-0.5	$V_{DD} + 0.1$	V
Continuous Total Power Dissipation			725 377	mW (25°C) mW (85°C)
Maximum Output Current	I_O		95	mA
Lead Solder Temperature (10s)			260	°C
ESD	2kV Human Body Model			

Insulation Specifications

Parameter	Condition	Min.	Typ.	Max.	Units
Creepage Distance (External)		8.077			mm
Barrier Impedance			$>10^{14} \parallel 7$		$\Omega \parallel pF$
Leakage Current	240 V _{RMS} 60Hz		0.2		μA

Recommended Operating Conditions

Parameters	Symbol	Min.	Max.	Units
Supply Voltage	V_{DD1} V_{DD2}	3.0 4.5	5.5 5.5	V
Input Voltage at any bus terminal (separately or common mode)	V_I V_{IC}		12 -7	V
High-Level Digital Input Voltage ($V_{DD1}=3.3$ V) ($V_{DD1}=5.0$ V)	V_{IH}	2.4 3.0		V
Low-Level Digital Input Voltage	V_{IL}		0.8	V
Differential Input Voltage ⁽²⁾	V_{ID}		± 12	V
High-Level Output Current (Driver)	I_{OH}		-60	mA
High-Level Digital Output Current (Receiver)	I_{OH}		8	mA
Low-Level Output Current (Driver)	I_{OL}		60	mA
Low-Level Digital Output Current (Receiver)	I_{OL}		8	mA
Operating Free Air Temperature	T_A	-40	85	°C
Digital Input Signal Rise and Fall Times	t_{IR}, t_{IF}	DC Stable		

IEC61010-1

TUV Certificate Numbers: *Pending*
Classification as Table 1.

Model	Pollution Degree	Material Group	Max Working Voltage	Package Type
IL422	II	III	400 V _{RMS}	16-SOIC (0.3") ✓

UL 1577

Component Recognition program. File # *Pending*
Rated 2500Vrms for 1min.

IL422-3V^{ISOLOOP®}

Driver Section

All Specifications are T_{min} to T_{max} unless otherwise stated.

Parameter	Symbol	Min.	Typ. ⁽⁵⁾	Max.	Units	Test Conditions
Input Clamp Voltage	V _{IK}			-1.5	V	I _L =-18mA
Output Voltage	V _O	0		6	V	I _O =0
Differential Output Voltage	V _{OD1}	1.5		6	V	I _O =0
Differential Output Voltage ⁽⁶⁾	V _{OD2}	1.5	2.5	5	V	R _L =54Ω
Differential Output Voltage	V _{OD3}	1.5		5	V	V _{test} =-7 to 12V
Change in Magnitude of ⁽⁷⁾ Differential Output Voltage	Δ V _{OD}			±0.2	V	R _L =54 or 100Ω
Common Mode Output Voltage	V _{OC}			3 -1	V	R _L =54 or 100Ω
Change in Magnitude of ⁽⁷⁾ Common Mode Output Voltage	Δ V _{OC}			±0.2	V	R _L =54 or 100Ω
Output Current ⁽⁴⁾	I _O			1 -0.8	mA mA	Output Disabled V _O =12 V _O =-7
High Level Input Current	I _{IH}			10	μA	V _I =3.5 V
Low Level Input Current	I _{IL}			-10	μA	V _I =0.4 V
Short-Circuit Output Current	I _{OS}			-250 -150 250	mA	V _O = -6 V _O = 0 V _O = 8
Supply Current (V _{DD2} = +5V)	I _{DD2}		27	34	mA	No Load (Outputs Enabled)
(V _{DD1} = +5V)	I _{DD1}		5	10		
(V _{DD1} = +3.3V)	I _{DD1}		3.2	7		
Switching Characteristics						
Parameter	Symbol	Min.	Typ. ⁽⁵⁾	Max.	Units	Test Conditions
Maximum Data Rate		35			Mbd	R _L =54Ω, C _L =50pF
Differential Output Delay Time	t _{D(OD)}		16	25	ns	R _L =54Ω, C _L =50pF
Pulse Skew ⁽¹⁰⁾	t _{SK(P)}		1	6	ns	R _L =54Ω, C _L =50pF
Differential Output Transition Time	t _{T(OD)}		8	10	ns	R _L =54Ω, C _L =50pF
Output Enable Time To High Level	t _{PZH}		31	65	ns	R _L =54Ω, C _L =50pF
Output Enable Time To Low Level	t _{PZL}		22	35	ns	R _L =54Ω, C _L =50pF
Output Disable Time From High Level	t _{PHZ}		28	50	ns	R _L =54Ω, C _L =50pF
Output Disable Time From Low Level	t _{PLZ}		16	32	ns	R _L =54Ω, C _L =50pF
Skew Limit ⁽³⁾	t _{SK(LIM)}		2	8	ns	R _L =54Ω, C _L =50pF

IL422-3V^{IsoLoop®}

Receiver Section

All Specifications are T_{min} to T_{max} unless otherwise stated.

Parameter	Symbol	Min.	Typ. ⁽⁶⁾	Max.	Units	Test Conditions
Positive-going Input Threshold Voltage	V _{IT+}			0.2	V	V _O = 2.7V, I _O = -0.4mA
Negative-going Input Threshold Voltage	V _{IT-}	-0.2			V	V _O = 0.5V, I _O = 8mA
Hysteresis Voltage (V _{IT+} - V _{IT-})	V _{hys}		60		mV	
High Level Digital Output Voltage	V _{OH}	V _{DD} - 0.2			V	V _{ID} = 200mV, I _{OH} = -20μA
Low Level Digital Output Voltage	V _{OL}			0.2	V	V _{ID} = -200mV, I _{OL} = 20μA
High-impedance-state output current	I _{OZ}			±10	μA	V _O = 0.4 to (V _{DD2} - 0.5) V
Line Input Current ⁽⁸⁾	I _I			1 -0.8	mA	Other Input ⁽¹¹⁾ = 0V V _I = 12V V _I = -7V
Input Resistance	r _I		50		kΩ	
Supply Current (V _{DD2} = +5V)	I _{DD2}		27	34	mA	No Load (Outputs Enabled)
(V _{DD1} = +5V)	I _{DD1}		5	10		
(V _{DD1} = +3.3V)	I _{DD1}		3.2	7		
Switching Characteristics @ 5V						
Parameter	Symbol	Min.	Typ. ⁽⁶⁾	Max.	Units	Test Conditions
Maximum Data Rate		25			Mbd	R _L = 54Ω, C _L = 50pF
Propagation Time ⁽⁹⁾	t _{PD}		24	32	ns	V _O = -1.5 to 1.5V, C _L = 15pF
Pulse Skew ⁽¹⁰⁾	t _{SK(P)}		1	6	ns	V _O = -1.5 to 1.5V, C _L = 15pF
Skew Limit ⁽⁵⁾	t _{SK(lim)}		2	8	ns	R _L = 54Ω, C _L = 50pF
Output Enable Time To High Level	t _{PZH}		17	24	ns	C _L = 15pF
Output Enable Time To Low Level	t _{PZL}		30	45	ns	C _L = 15pF
Output Disable Time From High Level	t _{PHZ}		30	45	ns	C _L = 15pF
Output Disable Time From Low Level	t _{PLZ}		18	27	ns	C _L = 15pF
Switching Characteristics @ 3.3V						
Parameter	Symbol	Min.	Typ. ⁽⁶⁾	Max.	Units	Test Conditions
Maximum Data Rate		25			Mbd	R _L = 54Ω, C _L = 50pF
Propagation Time ⁽⁹⁾	t _{PD}		27	32	ns	V _O = -1.5 to 1.5V, C _L = 15pF
Pulse Skew ⁽¹⁰⁾	t _{SK(P)}		2	6	ns	V _O = -1.5 to 1.5V, C _L = 15pF
Skew Limit ⁽⁵⁾	t _{SK(lim)}		4	8	ns	R _L = 54Ω, C _L = 50pF
Output Enable Time To High Level	t _{PZH}		20	24	ns	C _L = 15pF
Output Enable Time To Low Level	t _{PZL}		33	45	ns	C _L = 15pF
Output Disable Time From High Level	t _{PHZ}		33	45	ns	C _L = 15pF
Output Disable Time From Low Level	t _{PLZ}		20	27	ns	C _L = 15pF

Electrostatic Discharge Sensitivity

This product has been tested for electrostatic sensitivity to the limits stated in the specifications. However, NVE recommends that all integrated circuits be handled with appropriate care to avoid damage. Damage caused by inappropriate handling or storage could range from performance degradation to complete failure.

IL422-3V^{IsoLoop®}

Notes:

1. All Voltage values are with respect to network ground except differential I/O bus voltages.
2. Differential input/output voltage is measured at the noninverting terminal A/Y with respect to the inverting terminal B/Z.
3. Skew limit is the maximum difference in any two channels in one device.
4. The power-off measurement in ANSI Standard EIA/TIA-422-B applies to disabled outputs only and is not applied to combined inputs and outputs.
5. All typical values are at $V_{DD1}, V_{DD2} = 5V$ and $T_A = 25^\circ C$.
6. The minimum V_{OD2} with a 100Ω load is either $\frac{1}{2}V_{OD1}$ or $2V$, whichever is greater.
7. $\Delta|V_{OD}|$ and $\Delta|V_{OC}|$ are the changes in magnitude of V_{OD} and V_{OC} , respectively, that occur when the input is changed from one logic state to the other.
8. This applies for both power on and power off, refer to ANSI standard RS-485 for exact condition. The EIA/TIA-422-B limit does not apply for a combined driver and receiver terminal.
9. Includes 8 ns read enable time. Maximum propagation delay is 25 ns after read assertion.
10. Pulse skew is defined as the $|t_{PLH} - t_{PHL}|$ of each channel.

Application Notes:

Power Consumption

Isoloop® devices achieve their low power consumption from the manner by which they transmit data across the isolation barrier. By detecting the edge transitions of the input logic signal and converting these to narrow current pulses a magnetic field is created around the GMR Wheatstone bridge. Depending on the direction of the magnetic field, the bridge causes the output comparator to switch following the input logic signal. Since the current pulses are narrow, about 2.5ns wide, the power consumption is independent of mark-to-space ratio and solely dependent on frequency. This has obvious advantages over optocouplers whose power consumption is heavily dependent on its on-state and frequency.

The approximate power supply current per channel for

$$\text{Isoloop}^\circ \text{ is: } I(\text{input}) = 40 \left(\frac{f}{f_{\text{max}}} \right) \left(\frac{1}{4} \right) \text{ mA}$$

where f = operating frequency

$$f_{\text{max}} = 50 \text{ MHz}$$

Power Supplies

It is recommended that low ESR ceramic capacitors be used to decouple the supplies. Both V_{DD1} and V_{DD2} should be bypassed with 47 nF capacitors. These should be placed no further than 1 cm from the device pins for proper operation. In addition, V_{DD2} should have a 10 μF tantalum capacitor connected in parallel with the 47 nF capacitor.

IL422-3V^{IsoLoop[®]}

Pin Configuration

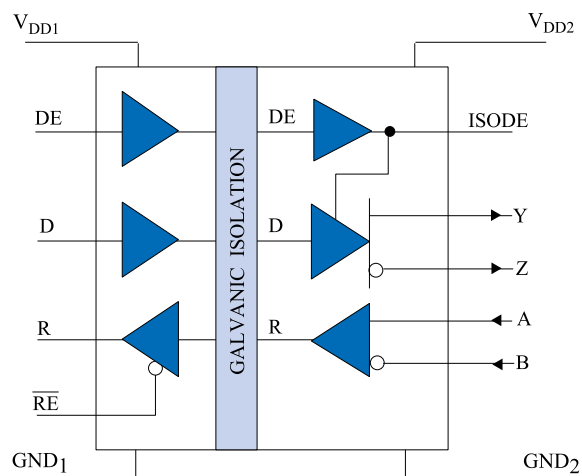
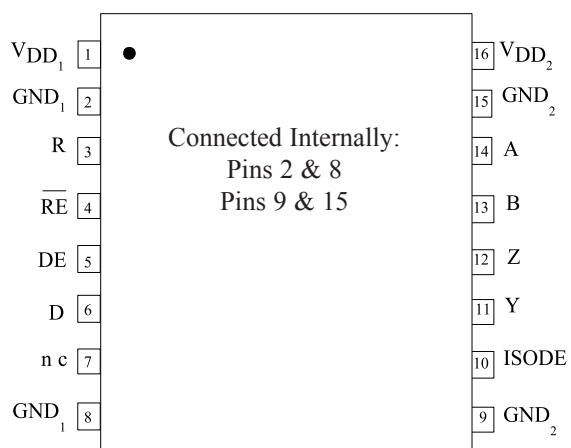

Pin Description

Pin	Mnemonic	Description
1	V _{DD1}	Input Power Supply
2	GND ₁	Input Power Supply Ground Return
3	R	Output Data from AB Bus
4	RE	Read Data Enable (If RE is high, R is High Impedence)
5	DE	Drive Enable
6	D	Data Input to YZ Bus
7	nc	No Internal Connection
8	GND ₁	Input Power Supply Ground Return
9	GND ₂	Output Power Supply Ground Return
10	ISODE	Isolated DE Output for use in applications where the state of the drive enable node needs to be monitored
11	Y	'Y' Bus (Drive — True)
12	Z	'Z' Bus (Drive — Inverse)
13	B	'B' Bus (Receive — Inverse)
14	A	'A' Bus (Receive — True)
15	GND ₂	Output Power Supply Return
16	V _{DD2}	Output Power Supply

IL422-3V^{IsoLoop®}

IL422-3V (0.3" SOIC-16 Package)

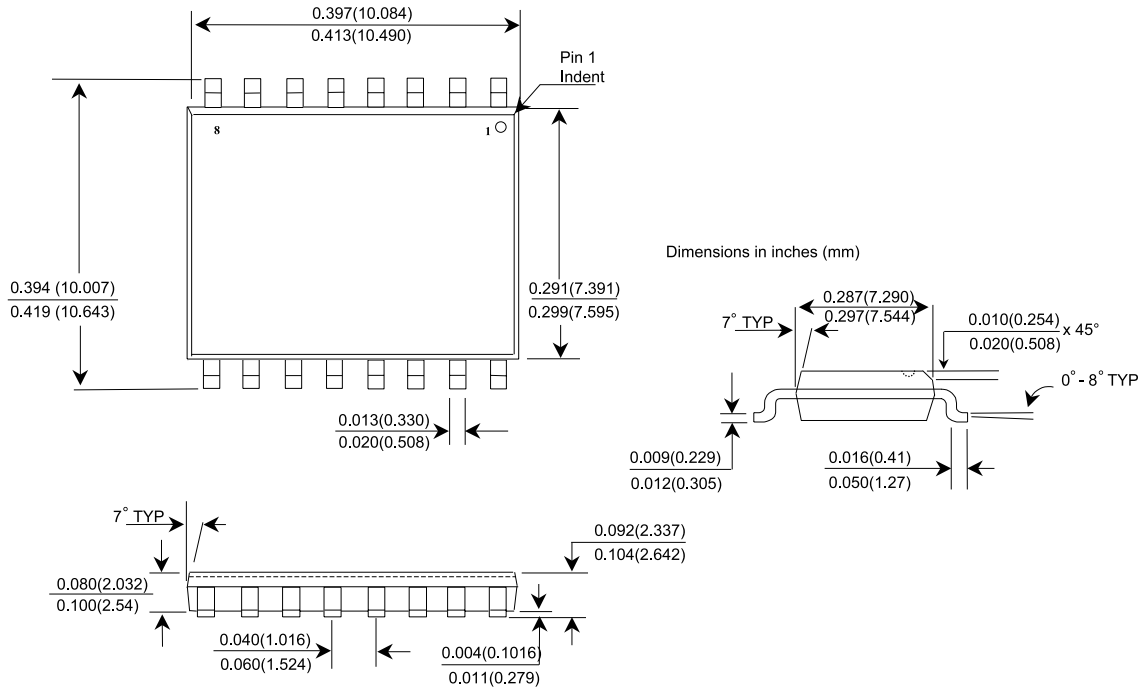

IR Soldering Profile

Recommended profile shown. Maximum temperature allowed on any profile is 260° C.

