

## 2-Line Color CCD Linear Sensor with a 1-Line Spacing

# ILX538K

Along with the current rapid growth in the personal computer market, the color image scanner is poised for rapid growth. Although Sony has already developed a line of products for color image scanners, we have now developed a new product to support A4-size documents at a density of 600 DPI : the ILX538K 2-line color linear sensor with a 1-line spacing.

- 2-line color linear sensor consisting of an R and B dot-sequential line and a G line
- Pixel line spacing of 1 line
- Analog memory included in the CCD block.
- Pixel size corresponding to a 7- $\mu$ m pitch
- Ultra-low lag
- Excellent linearity
- Built-in clamp circuit
- Built-in sample-and-hold circuit

### 2-Line Color Linear Sensor Consisting of an R and B Dot-sequential Line and a G Line

Figure 1 shows the block diagram for a 3-line sensor and figure 2 shows the block diagram of the ILX538K sensor block. In 3-line sensors, the pixel lines are usually separated by a spacing of several pixel widths. Application systems normally compensate for this by providing external memory and performing interline interpolation as synchronization processing. The ILX538K consists of 2 lines, a dot-sequential R and B line and a G line and succeeds in reducing the interline spacing to just 1 line.

### Analog Memory for Line Synchronization Provided in the CCD Block

The ILX538K includes one line of analog memory for each of the R/B and G sensor lines and the CCD registers. It is possible to perform line data synchronization for the 2-sensor lines using this memory. This makes external correction (line data synchronization) memory unnecessary, and can significantly simplify the peripheral circuits. Since this analog memory is provided for both the R/B and G lines, line data synchronization can be performed for scanning in either direction, thus provide a high degree of freedom in end product design.

### Pixel Size Corresponding to a 7- $\mu$ m Pitch

Figure 3 shows the block diagram of the ILX538K. One of the sensor lines is an R/B dot-sequential lines and the other is the G line. This structure allows the ILX538K to achieve a minimum line spacing of 1 line (7  $\mu$ m), which is equal to the pixel spacing. Table 1 presents an overview of the characteristics of the ILX538K. The effective pixel size is 5 $\times$ 6  $\mu$ m (for a 7  $\mu$ m pitch), and the ILX538K achieves the high pixel counts of 2670 effective pixels for the R and B lines and 5340 for the G line.

### Excellent Linearity

Table 2 lists the electro-optical characteristics of the ILX538K. Since the sensor block signal charges are fully read out, there is no lag. Also, the ILX538K provides excellent linearity from small signals through the saturation output voltage.

### Built-in Clamp and Sample-and-Hold Circuits

The ILX538K includes both clamp and sample-and-hold circuits for all signal outputs. Also, the ILX538K provides two independent parallel sample-and-hold circuits for the R/B dot-sequential output circuits, so that the R and B signals can be output separately to individual output pins.

## V O I C E

Of the 600 DPI color linear sensors developed to date, the ILX538K best provides the three critical sensor aspects; namely a small pixel size, ease of use, and a narrow line spacing. I'm sure that this device will be well received in the color image scanner market as the indispensable key device for driving further expansion of that market. Once you have been introduced to this product, you will find it truly indispensable.





New  
Products

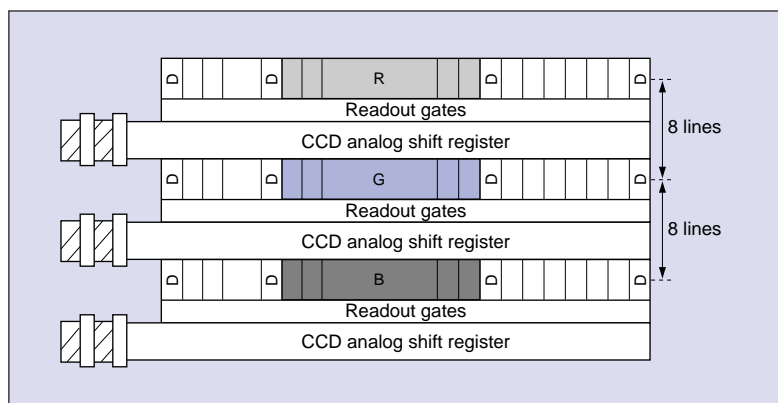

Figure 1 Block Diagram of the Sensor Block in a 3-Line Sensor

Table 1 ILX538K Overview

Item	ILX538K
Number of effective pixels	2670 pixels × 2 (R/B), 5340 pixels (G)
Effective pixel size	5μm × 6μm
Pixel pitch	7 μm
Line spacing	1 line (7 μm)
Resolution	600 DPI (A4)
Power supply	Single 10-V power supply
Package	22pin Cer-DIP

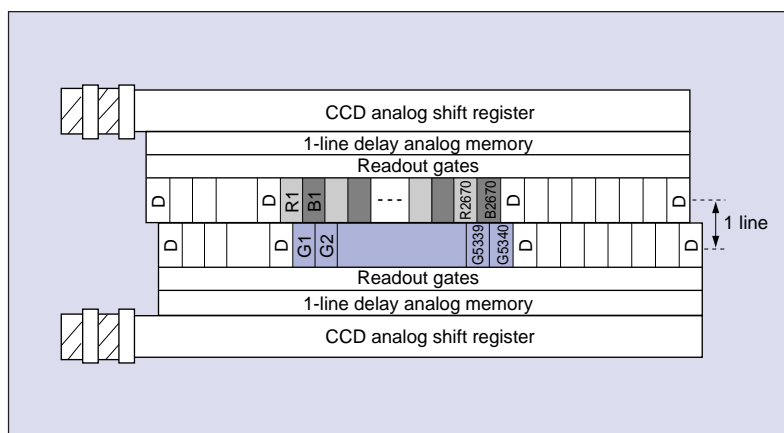

Figure 2 Block Diagram of ILX538K Sensor Block

Table 2 Electro-Optical Characteristics

Item	Typical value		Unit
	R	G	
Sensitivity	R	1.1	V/(lx·s)
	G	2	
	B	1.2	
Sensitivity nonuniformity	5	%	
Saturation output voltage	1.5	V	
Image lag	0.02	%	
Total transfer efficiency	98	%	
Current consumption	20	mA	
Maximum operating frequency	2	MHz	

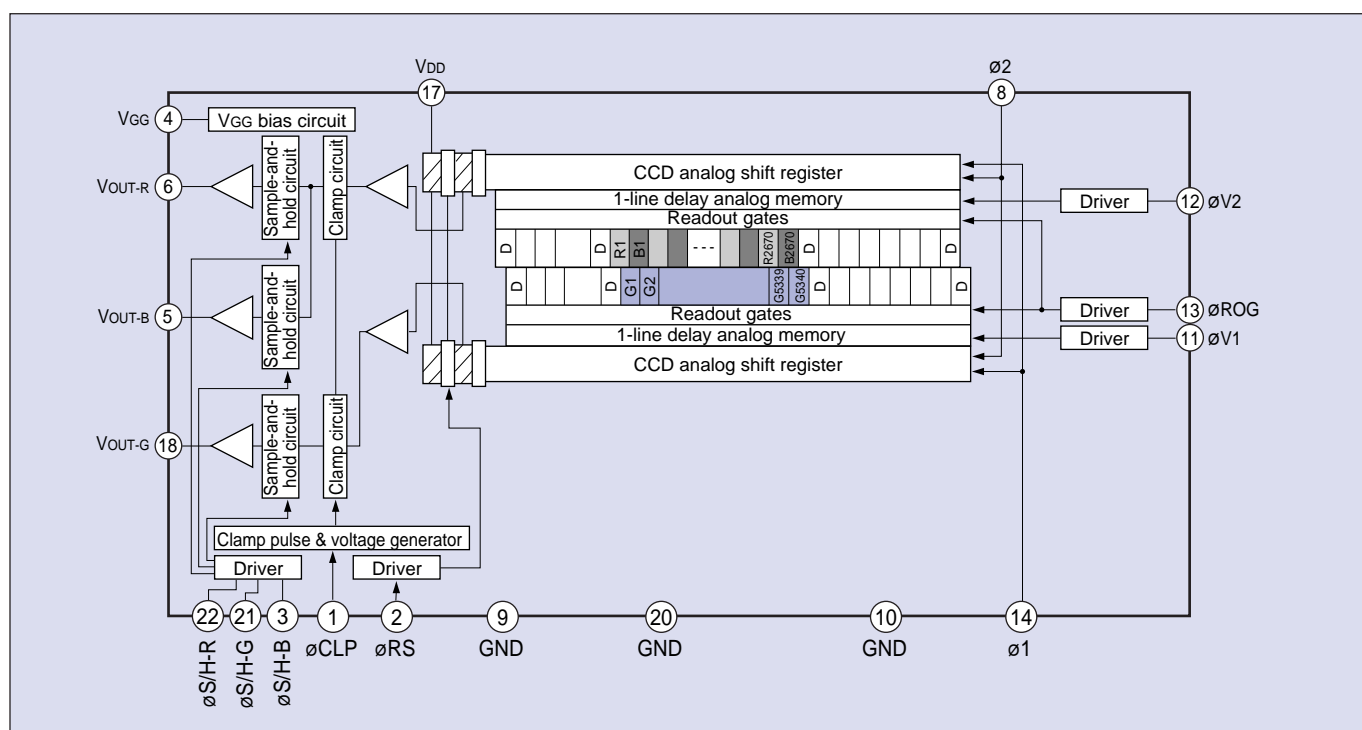

Figure 3 ILX538K Block Diagram