

IP1524 SERIES

TOP VIEW

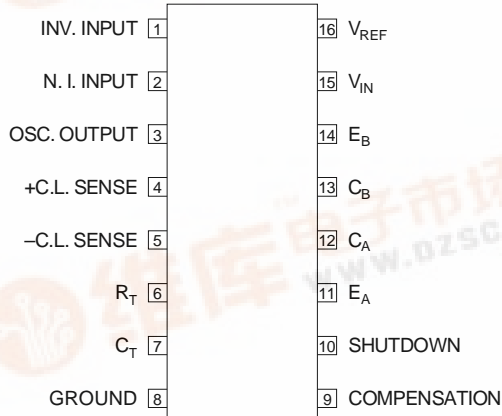

- J Package – 16 Pin Ceramic DIP
- N Package – 16 Pin Plastic DIP
- D Package – 16 Pin Plastic (150) SOIC

REGULATING PULSE WIDTH MODULATORS

FEATURES

- Guaranteed $\pm 2\%$ reference voltage tolerance
- Guaranteed $\pm 6\%$ oscillator tolerance
- Fully specified temperature performance
- Guaranteed 10mV/1000 hours long term stability
- Interchangeable with SG1524 series

Order Information

Part Number	J-Pack 16 Pin	N-Pack 16 Pin	D-16 16 Pin	Temp. Range	Note:
IP1524	✓			-55 to +125°C	To order, add the package identifier to the part number. eg. IP1524J IP3524D-16
IP2524	✓	✓	✓	-25 to +85°C	
IP3524	✓	✓	✓	0 to +70°C	

ABSOLUTE MAXIMUM RATINGS (T_{case} = 25°C unless otherwise stated)

+V _{IN}	Input Voltage		+40V
	Collector Voltage		+40V
	Output Current	(each transistor)	100mA
	Reference Load Current		Internally Limited
	Oscillator Charging Current		5mA
	Shut Down Pin Voltage		+5.5V
	Current Limit Sense Common Mode Range		-1.0 to +1.0V
P _D	Power Dissipation	T _A = 25°C	1W
		Derate @ T _A > 50°C	10mW/°C
P _D	Power Dissipation	T _C = 25°C	2W
		Derate @ T _C > 25°C	16mW/°C
	Operating Junction Temperature		See Ordering Information
	Storage Temperature Range		-65 to +150°C
T _L	Lead Temperature	(soldering, 10 seconds)	+300°C



DESCRIPTION

The IP1524 series of PWM switching regulator control circuits contains all the functions required to implement single-ended or push-pull switching regulators. Included are voltage reference, error amplifier, oscillator, PWM comparator, output drivers, current limiting and shutdown circuitry.

Although functionally identical to the SG1524 series, SEMELAB has incorporated several improvements to the IP1524 allowing tighter and more complete specification of electrical performance.

BLOCK DIAGRAM

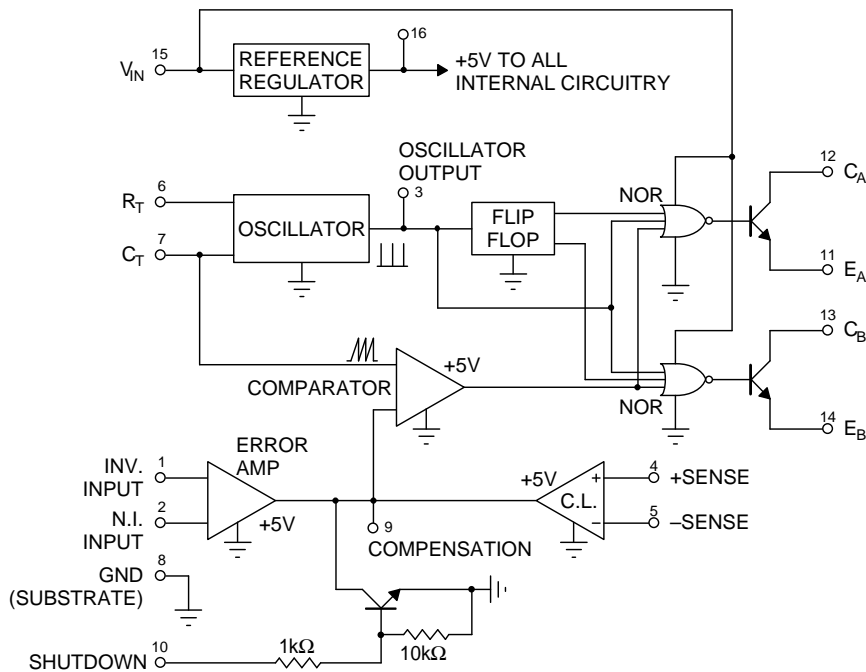

RECOMMENDED OPERATING CONDITIONS

V_{IN}	Input Voltage		+8 to +40V
	Collector Voltage		0 to +40V
	Error Amp Common Mode Range		+1.8 to +3.4V
	Output Current	(each transistor)	0 to 100mA
	Reference Load Current		0 to 20mA
	Oscillator Charging Current		30 μ A to 2mA
	Oscillator Frequency Range		50Hz to 500kHz
R_T	Oscillator Timing Resistor		1.8k Ω to 100k Ω
C_T	Oscillator Timing Capacitor		1nF to 0.1 μ F
T_{AMB}	Operating Ambient Temperature Range	IP1524	-55 to +125°C
		IP2524	-25 to +85°C
		IP3524	0 to +70°C

ELECTRICAL CHARACTERISTICS (T_J = 25°C unless otherwise stated)

Parameter	Test Conditions ¹	IP1524 IP2524			IP3524			Units
		Min.	Typ.	Max.	Min.	Typ.	Max.	
REFERENCE SECTION								
Output Voltage	T _J = Over Temp. Range	4.90	5.00	5.10	4.60	5.00	5.40	V
Line Regulation	+V _{IN} = 8 to 40V T _J = Over Temp. Range		1	10		10	30	mV
Load Regulation	I _L = 0 to 20mA T _J = Over Temp. Range		5	20		20	50	
Ripple Rejection	f = 120Hz		80			66		dB
Short Circuit Current	V _{REF} = 0 T _J = Over Temp. Range	25	50	120		100		mA
Temperature Stability	T _J = Over Temp. Range		0.3	1		0.3	1	%
Long Term Stability	T _J = 125°C		1	10		20		mV / khr
OSCILLATOR SECTION								
Initial Accuracy	R _T = 2.7kΩ C _T = 0.01μF			6		5		%
Voltage Stability	+V _{IN} = 8 to 40V		0.1	1		0.5	1	
Temperature Stability	T _J = Over Temp. Range		1	2			2	
Minimum Frequency	R _T = 100kΩ C _T = 0.1μF T _J = Over Temp. Range		120	240		120		Hz
Maximum Frequency	R _T = 2kΩ C _T = 0.001μF T _J = Over Temp. Range	200	300			300		kHz
Sawtooth Peak Voltage	C _T = 0.01μF		3.6			3.6		V
Sawtooth Valley Voltage	C _T = 0.01μF	0.6	1			1		
Clock Amplitude	Output, Pin 3 C _T = 0.01μF T _J = Over Temp. Range	3.0	4.0			3.5		V
Clock Pulse Width	Output, Pin 3 C _T = 0.01μF	0.3	0.5	1.0		0.5		μs
ERROR AMP SECTION ²								
Input Offset Voltage	T _J = Over Temp. Range		0.1	5		2	10	mV
Input Bias Current	T _J = Over Temp. Range		1	2		1	10	μA
Input Offset Current	T _J = Over Temp. Range			0.5			1	
DC Open Loop Gain	T _J = Over Temp. Range	72	80		60	80		dB
Output Low Level	V _{PIN1} - V _{PIN2} ≥ 150mV			0.5			0.5	V
Output High Level	V _{PIN2} - V _{PIN1} ≥ 150mV	3.8			3.8			
Common Mode Rejection		70	90		70			dB
Supply Voltage Rejection	+V _{IN} = 8 to 40V	70	100		70			
Gain Bandwidth Product			3			3		MHz

NOTES

1. Test Conditions unless otherwise stated: V_{IN} = 20V, I_{REF} = 0.
2. V_{CM} = +1.8 to +3.4V
3. V_{CM} = -1 to +1V

ELECTRICAL CHARACTERISTICS (T_J = 25°C unless otherwise stated)

Parameter	Test Conditions ¹	IP1524 IP2524			IP3524			Units
		Min.	Typ.	Max.	Min.	Typ.	Max.	
PWM COMPARATOR								
Minimum Duty Cycle	V _{PIN1} - V _{PIN2} ≥ 150mV T _J = Over Temp. Range			0			0	%
Maximum Duty Cycle	V _{PIN2} - V _{PIN1} ≥ 150mV T _J = Over Temp. Range	45	49		45	49		%
CURRENT LIMIT AMPLIFIER ³								
Sense Voltage	V _{CM} = 0	190	200	210	180	200	220	mV
	V _{CM} = 0 T _J = Over Temp. Range	170	200	230		200		
SHUTDOWN INPUT								
High Input Voltage	V _{PIN9} ≤ 0.6V T _J = Over Temp. Range	1.2			1.2			V
High Input Current	V _{SHUTDOWN} = +5V T _J = Over Temp. Range		4	8		4		mA
Low Input Voltage	V _{PIN9} ≥ 3.5V T _J = Over Temp. Range			0.3			0.3	V
OUTPUT SECTION (each transistor)								
Collector – Emitter Voltage	I _C = 50μA T _J = Over Temp. Range	40			40			V
Collector Leakage Current	V _{CE} = 40V T _J = Over Temp. Range		0.1	50		0.1	50	μA
Collector Saturation Voltage	I _C = 50mA T _J = Over Temp. Range		1	2		1	2	V
Emitter Output Voltage	V _{IN} = 20V T _J = Over Temp. Range	17	18		17	18		V
Emitter Voltage Rise Time	R _E = 2kΩ		0.2	0.4		0.2		μs
Collector Voltage Fall Time	R _C = 2kΩ		0.1	0.2		0.1		
POWER CONSUMPTION								
Standby Current	V _{IN} = 40V T _J = Over Temp. Range		5	10		5	10	mA

NOTES

1. Test Conditions unless otherwise stated: V_{IN} = 20V , I_{REF} = 0.
2. V_{CM} = +1.8 to +3.4V
3. V_{CM} = -1 to +1V

APPLICATIONS INFORMATION

The IP1524 is a fixed-frequency pulse-width modulation voltage regulator control circuit. The regulator operates at a frequency that is programmed by one timing resistor (R_T) and one timing capacitor (C_T). R_T establishes a constant charging current for C_T , which is fed to the comparator providing linear control of the output pulse width by the error amplifier.

The IP1524 contains an on-board 5V regulator that serves as a reference as well as powering the IP1524's internal control circuitry and is also useful in supplying external support functions. This reference voltage is lowered externally by a resistor divider to provide a reference within the common-mode range of the error amplifier or an external reference may be used. The power supply output is sensed by a second resistor divider network to generate a feedback signal to the error amplifier. The amplifier output voltage is then compared to the linear voltage ramp at C_T . The resulting modulated pulse out of the high-gain comparator is then steered to the appropriate output pass transistor (Q_1 or Q_2) by the pulse-steering flip-flop, which is synchronously toggled by the oscillator output.

The oscillator output pulse also serves as a blanking pulse to assure both outputs are never on simultaneously during the transition times.

The width of the blanking pulse is controlled by the value of C_T .

The outputs may be applied in a push-pull configuration in which their frequency is half that of the base oscillator, or paralleled for single-ended applications in which the frequency is equal to that of the oscillator. The output of the error amplifier shares a common input to the comparator with the current limiting and shutdown circuitry and can be overridden by signals from either of these inputs.

This common point is also available externally and may be employed to control the gain of, or to compensate, the error amplifier, or to provide additional control to the regulator.

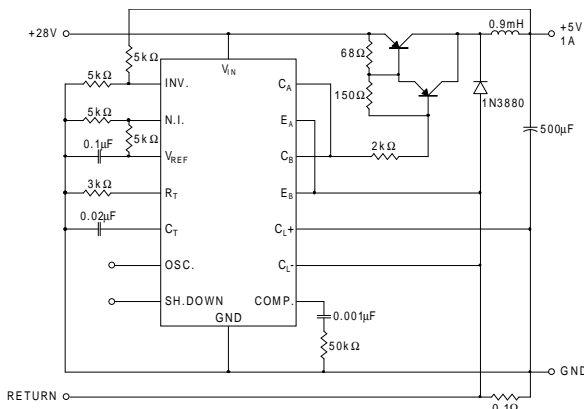

In this conventional single-ended regulator circuit, the two outputs of the IP1524 are connected in parallel for effective 0-90% duty cycle modulation. The use of an output inductor requires an R-C phase compensation network for loop stability.

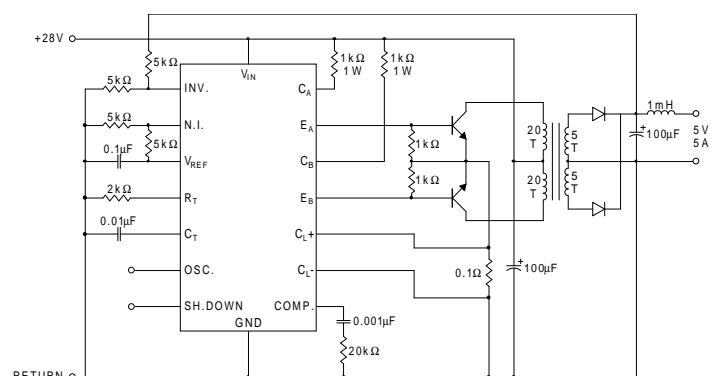

Push-pull outputs are used in this transformer-coupled DC-DC regulating converter. Note that the oscillator must be set at twice the desired output frequency as the IP1524's internal flip-flop divides the frequency by 2 as it switches the PWM signal from one output to the other. Current limiting is done in the primary so that the pulse width will be reduced should transformer saturation occur.

TYPICAL PERFORMANCE CHARACTERISTICS

Open-Loop Voltage Amplification of Error Amplifier vs. Frequency

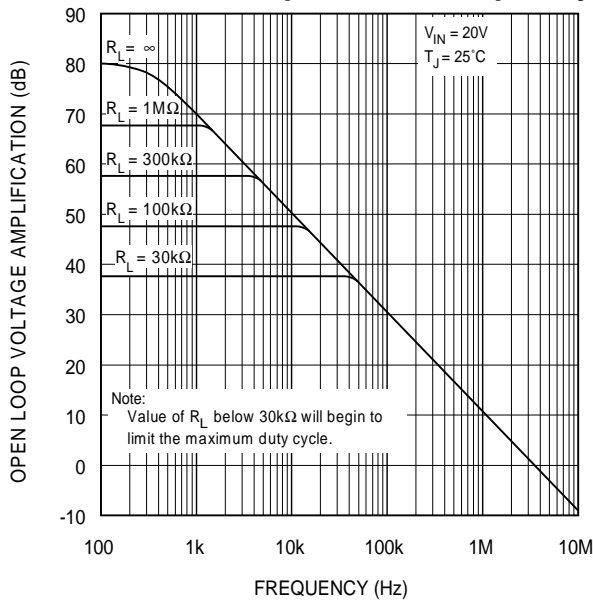

Oscillator Frequency vs. Timing Components

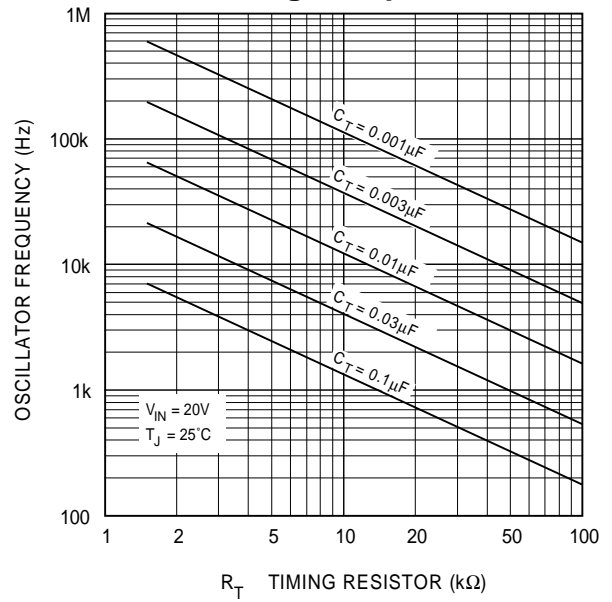

Output Dead Time vs. Timing Capacitance Value

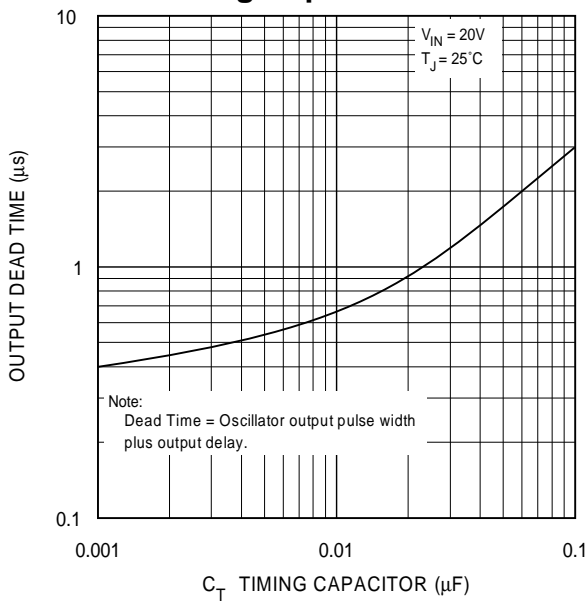

Output Saturation Voltage vs. Load Current

