

IP35063
IP33063
IP34063

TOP VIEW

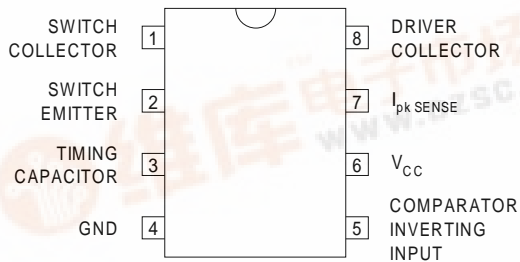

J Package – 8 Pin Ceramic DIP
N Package – 8 Pin Plastic DIP
D-8 Package – 8 Pin Plastic (150) SOIC

DC-DC CONVERTER CONTROL CIRCUIT

FEATURES

- Operation from 2.5 to 40V input
- Low Standby Current
- Current Limiting
- Output switch current of 1.5A
- Output voltage adjustable from 1.25 to 40V
- Operating frequency from 100Hz to 100kHz
- Direct replacement for MC34063/MC34063A series

Order Information

Part Number	J-Pack 8 Pin	N-Pack 8 Pin	D-8 8 Pin	Temp. Range	Note:
IP35063	✓			-55 to +125°C	To order, add the package identifier to the part number. eg. IP35063D-8
IP33063	✓	✓	✓	-40 to +85°C	
IP34063	✓	✓	✓	0 to +70°C	

ABSOLUTE MAXIMUM RATINGS

Power Supply Voltage		+40V
Comparator Input Voltage Range		-0.3V to +40V
Switch Collector Voltage		40V
Switch Emitter Voltage		40V
Switch Collector to Emitter Voltage		40V
Driver Collector Voltage		40V
Switch Current		1.5A
Power Dissipation @ T _{amb} = 25°C	Ceramic Packages	1.25W
	Plastic Packages	1W
Derate above 25°C		10mW/°C
Operating Junction Temperature	Ceramic Packages	150°C
	Plastic Packages	125°C
Operating Ambient Temperature Range	See Table Above	See Table Above
Storage Temperature Range		-65 to 150°C



DESCRIPTION

The IP34063 series of control circuits contains all the functions required to implement DC-DC converters. Included are internal voltage reference, comparator, controlled duty cycle oscillator with current limit circuit, driver, and high current output switch. This series was specifically designed to be incorporated in Step-Down (Buck) and Step-Up (Boost) applications with a minimum number of external components.

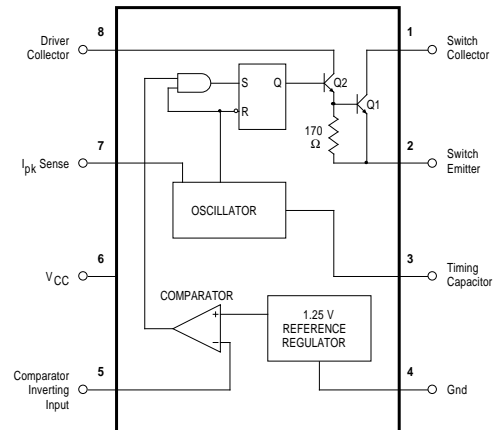

ELECTRICAL CHARACTERISTICS (Test Parameters unless otherwise stated : $V_{CC} = 5V$, $T_J = 25^\circ C$)

Parameter	Test Conditions	Min.	Typ.	Max.	Units
OSCILLATOR					
Charging Current	$V_{CC} = 5 \text{ to } 40V$	20	35	50	μA
Discharge Current	$V_{CC} = 5 \text{ to } 40V$	150	200	250	μA
Voltage Swing			0.5		Vpp
Discharge to Charge Current Ratio	$I_{pk(sense)} = V_{CC}$		6.0		—
Current Limit Sense Voltage	$I_{chg} = I_{dischg}$	250	300	350	mV
OUTPUT SWITCH					
Saturation Voltage, Darlington Connection *	$I_{SW} = 1.0A$		1	1.3	V
Saturation Voltage *	$I_{SW} = 1.0A$ $I_{C(Driver)} = 50mA$ (Forced $\beta = 20$)		0.45	0.7	V
DC Current Gain	$I_{SW} = 1.0A$, $V_{CE} = 5.0V$	35	120		—
Collector Off-State Current	$V_{CE} = 40V$		10		nA
COMPARATOR					
Threshold Voltage *		1.18	1.25	1.32	V
Threshold Voltage Line Regulation *	$V_{CC} = 3 \text{ to } 40V$		0.04	0.2	mV/V
Input Bias Current *	$V_{IN} = 0V$		40	400	nA
TOTAL DEVICE					
Supply Current *	$V_{CC} = 5 \text{ to } 40V$ $C_T = 0.001\mu F$ $I_{pk(sense)} = V_{CC}$ $V_{PIN 5} > V_{th}$ Pin 2 = Gnd , Remaining Pins Open.		2.4	3.5	mA

NOTES

* Applies over full operating temperature range (see order information).

DESIGN FORMULA TABLE

Calculation	Step-Down	Step-Up
$\frac{t_{ON}}{t_{OFF}}$	$\frac{V_{OUT} + V_F}{V_{IN(MAX)} - V_{SAT} - V_{OUT}}$	$\frac{V_{OUT} + V_F - V_{IN(MIN)}}{V_{IN(MIN)} - V_{SAT}}$
$(t_{ON} + t_{OFF})_{MAX}$	$\frac{1}{f_{MIN}}$	$\frac{1}{f_{MIN}}$
C_T	$4 \times 10^{-5} t_{ON}$	$4 \times 10^{-5} t_{ON}$
$I_{pk(switch)}$	$2 I_{OUT(MAX)}$	$2 I_{OUT(MAX)} \frac{t_{ON} + t_{OFF}}{t_{OFF}}$
R_{SC}	$0.33 / I_{pk(switch)}$	$0.33 / I_{pk(switch)}$
$L_{(MIN)}$	$\frac{V_{IN(MAX)} - V_{SAT} - V_{OUT}}{I_{pk(switch)}} t_{ON(MAX)}$	$\frac{V_{IN(MIN)} - V_{SAT}}{I_{pk(switch)}} t_{ON(MAX)}$
C_O	$\frac{I_{pk(switch)} (t_{ON} + t_{OFF})}{8 V_{ripple(p-p)}}$	$\frac{I_{OUT} t_{ON}}{V_{ripple}}$

KEY

- V_{SAT} — Saturation voltage of the output switch.
 V_F — Forward voltage drop of the ringback rectifier.

The following power supply characteristics must be chosen:—

- V_{IN} — Nominal input voltage. If this voltage is not constant, then use $V_{IN(MAX)}$ for step-down and $V_{IN(Min)}$ for step-up converter.
- V_{OUT} — Desired output voltage, $V_{OUT} = 1.25 \left(1 + \frac{R2}{R1} \right)$.
- I_{OUT} — Desired output current.
- f_{MIN} — Minimum desired output switching frequency at the selected values for V_{IN} and I_O .
- $V_{ripple(p-p)}$ — Desired peak-to-peak output ripple voltage. In practice, the calculated value will need to be increased due to the capacitors equivalent series resistance and board layout. The ripple voltage should be kept to a low value since it will directly affect the line and load regulation.

APPLICATIONS INFORMATION

Step-Down Converter

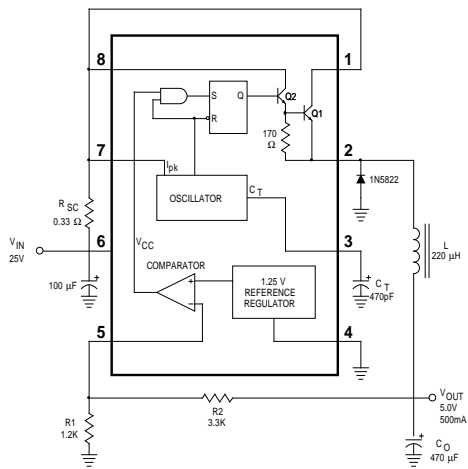

Step-Up Converter

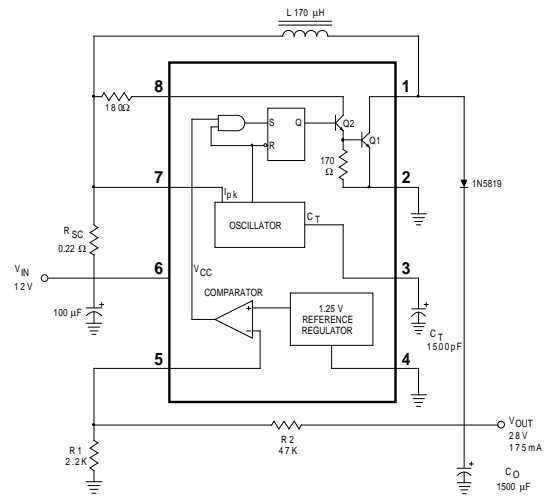

External Current Boost Connections for $I_C > 1.5A$

Step-Down, External NPN Switch

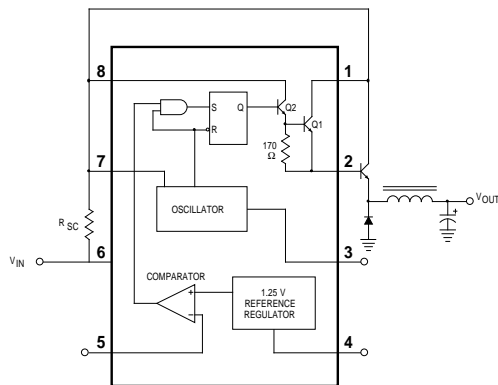

Step-Up, External NPN Switch

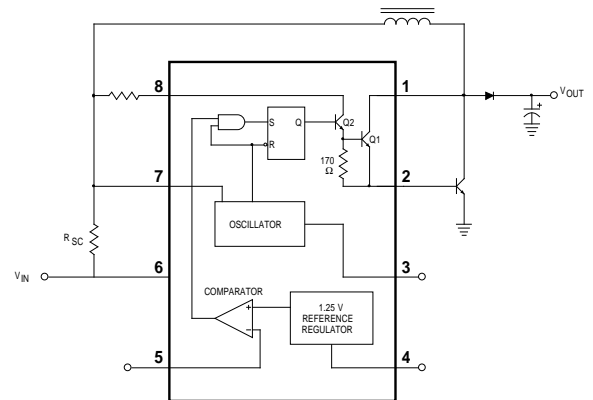

Step-Down, External PNP Saturated Switch

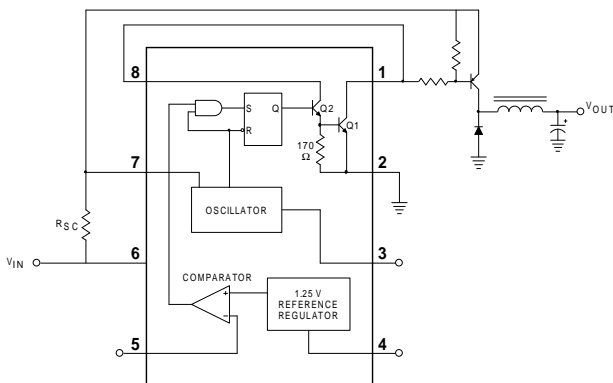

Step-Up, External NPN Saturated Switch

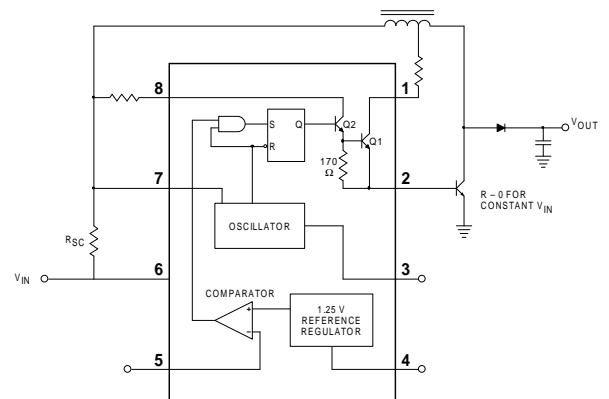

TYPICAL PERFORMANCE CHARACTERISTICS

Output Switch On-Off Time vs Oscillator Timing Capacitor

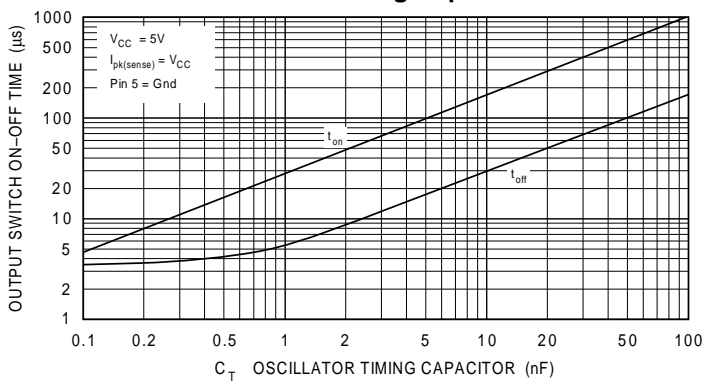

Standby Supply Current vs Supply Voltage

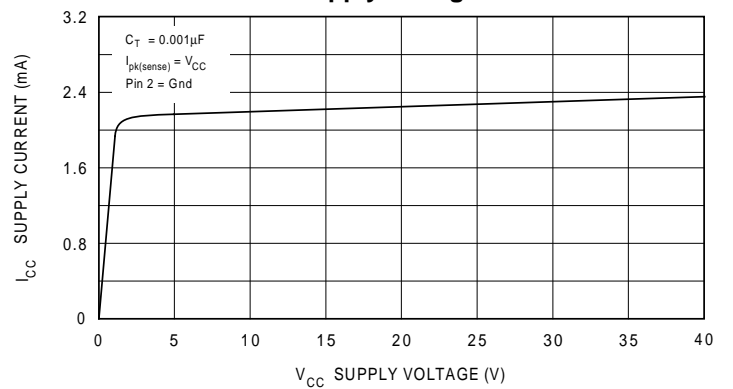

Emitter-Follower Configuration Output Switch Saturation Voltage vs Emitter Current

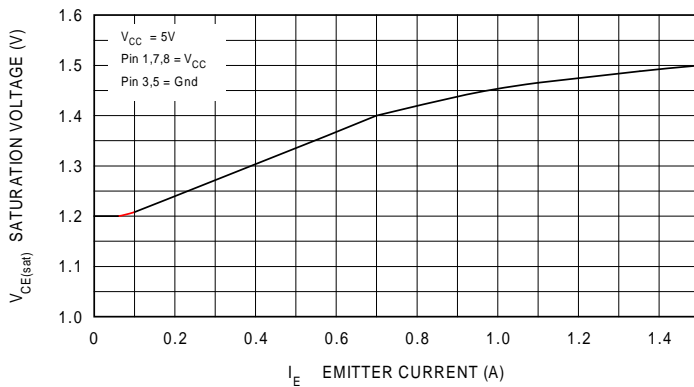

Common-Emitter Configuration Output Switch Saturation Voltage vs Collector Current

