

## Dual High Speed Laser Driver

The HIP9022 Dual High Speed Laser Driver is designed to operate with a constant current drain from the power supply. This current defines the laser operating power. The current is accurately controlled in the range of 0.5A to 2A to deliver constant optical power from the laser when used with an external Power FET and Power Sense resistor. The operating circuit allows flexibility in choosing driver current levels.

Eight S/H circuits are multiplex bus controlled to provide analog data for the dual laser drivers. The bus is updated during the blanking period of the laser printer scan with a data rate up to 2.5MHz. A "thermo-electric-cooler" control circuit provides temperature control of the laser. Two on-chip ESD diodes protect each laser.

A principle advantage of the Dual High Speed Laser Driver is accomplished by managing the high currents externally with discrete Power FETs and thereby not forcing large switching currents to exist on the same IC substrate with the precision control circuitry.

## Ordering Information

| PART NUMBER | TEMP. RANGE (°C) | PACKAGE    | PKG. NO. |
|-------------|------------------|------------|----------|
| HIP9022AM   | 0 to 100         | 68 Ld PLCC | N68.95   |

## Features

- Dual High Speed Laser Driver with Data Rates up to 2.5MHz
- 0.5A to 2A Range of Constant Current Source Controlled to 0.1% Full Scale
- Low Signal Transients with Controlled Constant Current Switching
- Laser Optical Power Controlled to Better than 0.5%
- Thermoelectric Cooler (TEC) Circuit to Control Temperature to within 0.25°C
- Multiplexed Sample/Hold (S/H) Bus Interface
- Serial Diagnostic Bus with Multiplexed Output
- High Current ESD Diodes for Laser Diode Protection

## Applications

- Dual Laser Printer Driver

## Pinout

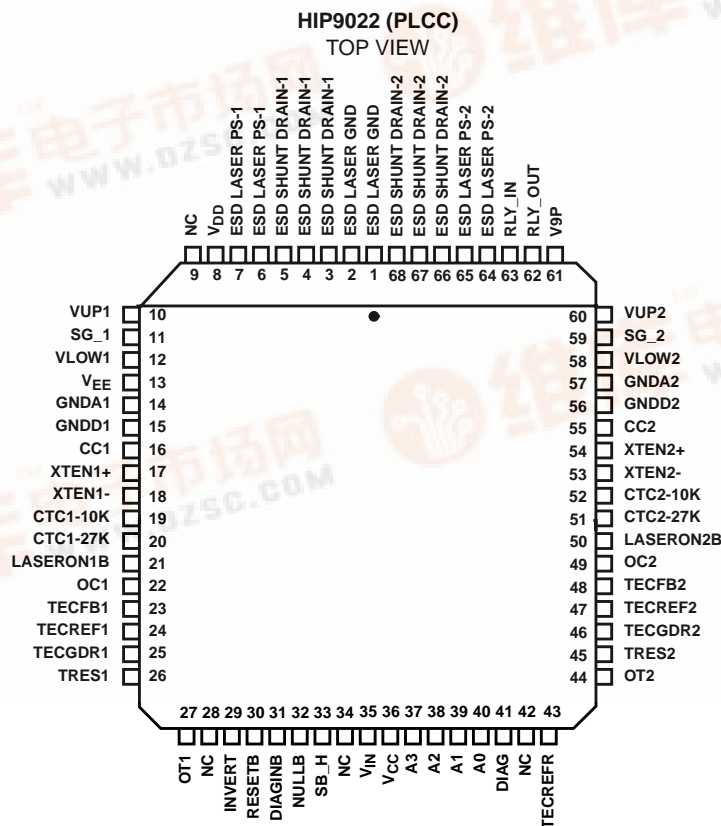

# HIP9022

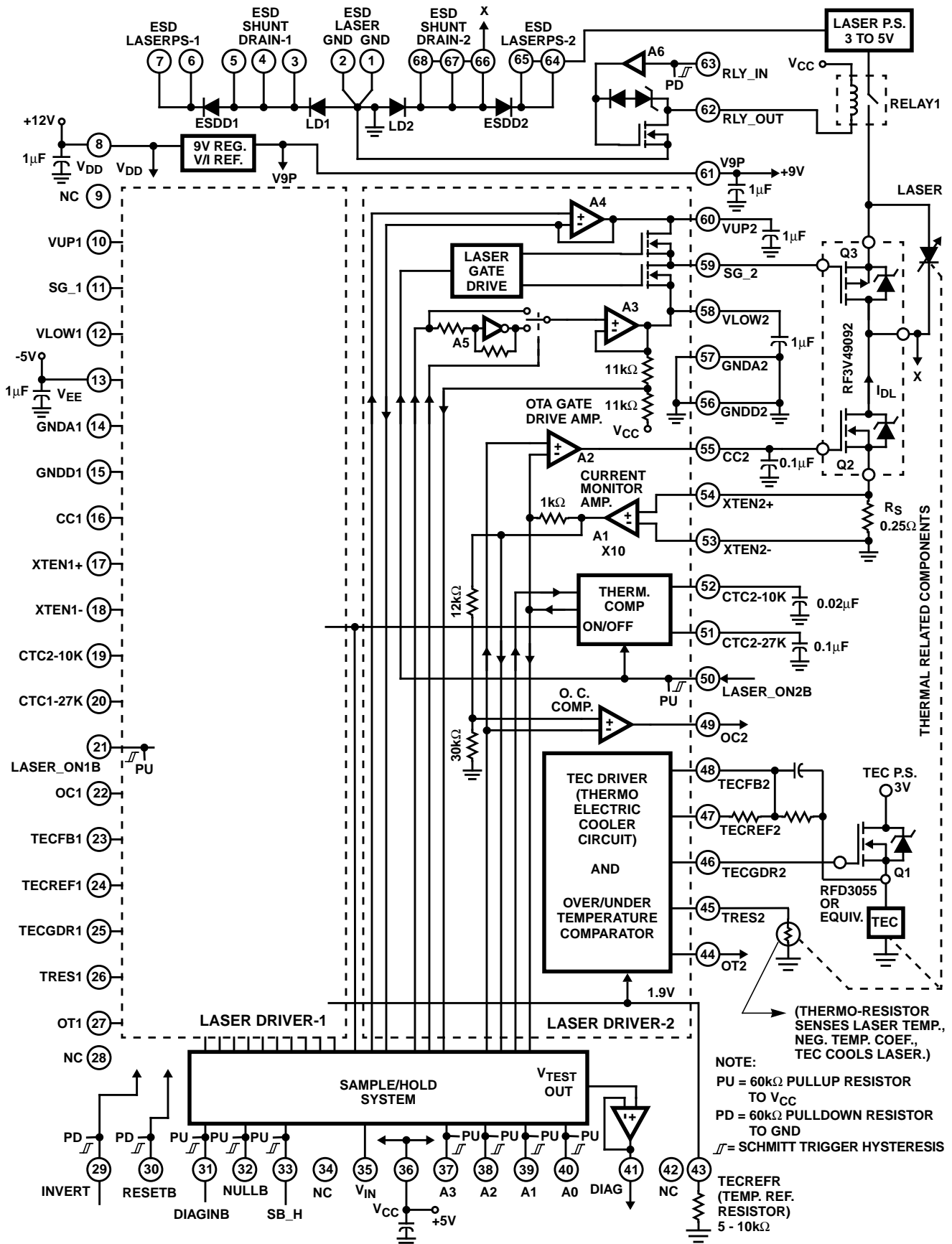

FIGURE 1. HIGH SPEED LASER DRIVER FUNCTIONAL BLOCK DIAGRAM SHOWN IN QUIESCENT P.S. CURRENT TEST MODE

## HIP9022

### Pin Descriptions

| PIN NUMBER | SYMBOL            | DESCRIPTION  |
|------------|-------------------|--|
| 1, 2       | ESD LASER GND     | Laser supply and system ground.  |
| 3, 4, 5    | ESD SHUNT DRAIN-1 | Laser diode ESD protection.  |
| 6, 7       | SD LASER PS-1     | Laser power supply ESD protection.   |
| 8          | V <sub>DD</sub>   | Input for 12V power supply.  |
| 9          | NC                | No connection.   |
| 10         | VUP1              | Filter capacitor for internally generated shunt gate upper voltage level (1μF).  |
| 11         | SG_1              | Drive output to shunt Power FET gate.  |
| 12         | VLOW1             | Filter capacitor for internally generated shunt Power FET gate lower drive voltage level (1μF).  |
| 13         | V <sub>EE</sub>   | Input for -5V power supply.  |
| 14         | GNDA1             | Analog Ground.   |
| 15         | GNDD1             | Digital Ground.  |
| 16         | CC1               | Gate drive to the current source Power FET.  |
| 17         | XTEN1+            | Times 10 constant current monitor amplifier input from the high side of the sense resistor.  |
| 18         | XTEN1-            | Times 10 constant current monitor amplifier input from the low side of the sense resistor.   |
| 19         | CTC1-10K          | Thermal compensation short time constant where T <sub>TC</sub> = External C x 10kΩ. (External C typically equal 0.02μF).   |
| 20         | CTC1-27K          | Thermal compensation long time constant where T <sub>TC</sub> = External C x 27kΩ. (External C typically equal 0.1μF).   |
| 21         | LASERON1B         | Input control turns shunt Power FET gate drive ON/OFF with 5V CMOS logic. Low turns the shunt Power FET OFF and the Laser ON. These pins have an internal pull-up.   |
| 22         | OC1               | Laser over-current indicator flag.   |
| 23         | TECFB1            | Feedback to stabilize the TEC loop.  |
| 24         | TECREF1           | Feedback to stabilize the TEC loop.  |
| 25         | TECGDR1           | Thermo-Electric Cooler Power FET gate drive.   |
| 26         | TRES1             | Thermo-Resistor output to ground connection for TEC control.   |
| 27         | OT1               | Laser out of temperature range indication.   |
| 28         | NC                | No connection.   |
| 29         | INVERT            | High input converts to operation with Pmos Current source and NDmos shunt Power FET external transistors. Low input converts to operation with NDmos Current source and Pmos high side shunt Power FET external transistors. This pin has an internal pull-down.   |
| 30         | RESETB            | When RESETB is held low, three reset actions occur. The LASERONB input is defeated to a Laser Off condition. The SG_1, 2 outputs are switched to VLOW when in the INVERT low mode and to VUP when in the INVERT high mode. The TEC amplifier is turned off to switch the TECGDR1, 2 outputs to Ground. This pin has an internal pull-down. |
| 31         | DIAGINB           | Low level activates the diagnostic mode. This pin has an internal pull-up.   |
| 32         | NULLB             | Auto-zeros the S/H amplifier selected by address when held low. This pin has an internal pull-up.  |
| 33         | SB_H              | Samples the selected address when held low. The setup time for address is <25ns. This pin has an internal pull-up.   |
| 34         | NC                | No connection.   |
| 35         | V <sub>IN</sub>   | Analog voltage sampled by selected S/H. The input voltage range is 0 to 5V. There is an internal voltage clamp for voltage outside of this range. There is an internal 2 - 3μs filter for noise rejection.   |
| 36         | V <sub>CC</sub>   | Input for 5V power supply.   |
| 37         | A3                | Refer to the Table 1 Address Map. The A3 - A0 pins have an internal pull-up.   |

## HIP9022

### Pin Descriptions (Continued)

| PIN NUMBER | SYMBOL            | DESCRIPTION  |
|------------|-------------------|--|
| 38         | A2                | Refer to the Table 1 Address Map. The A3 - A0 pins have an internal pull-up.   |
| 39         | A1                | Refer to the Table 1 Address Map. The A3 - A0 pins have an internal pull-up.   |
| 40         | A0                | Refer to the Table 1 Address Map. The A3 - A0 pins have an internal pull-up.   |
| 41         | DIAG              | Diagnostic output, A 0V - 5V analog signal output limits internally to a range of -0.3V to 5.3V. The output is the channel addressed by A0 - A3.                   |
| 42         | NC                | No connection.   |
| 43         | TECREFER          | External resistor to ground with a resistor value equal to the value of the thermo-resistor at the desired laser temperature. (Typically in the 5kΩ to 10kΩ range) |
| 44         | OT2               | Laser out of temperature range indication.   |
| 45         | TRES2             | Thermo-Resistor output to ground connection for TEC control.   |
| 46         | TECGDR2           | Thermo-Electric Cooler Power FET gate drive.   |
| 47         | TECREF2           | Feedback to stabilize the TEC loop.  |
| 48         | TECFB2            | Feedback to stabilize the TEC loop.  |
| 49         | OC2               | Laser over-current indicator flag.   |
| 50         | LASERON2B         | Input control turns shunt Power FET gate drive ON/OFF with 5V CMOS logic. Low turns the shunt Power FET OFF and the Laser ON. These pins have an internal pull-up. |
| 51         | CTC2-27K          | Thermal compensation long time constant where $T_{TC} = \text{External C} \times 27k\Omega$ . (External C typically equal 0.1μF).                                  |
| 52         | CTC2-10K          | Thermal compensation short time constant where $T_{TC} = \text{External C} \times 10k\Omega$ . (External C typically equal 0.02μF).                                |
| 53         | XTEN2-            | Times 10 constant current monitor amplifier input from the low side of the sense resistor.   |
| 54         | XTEN2+            | Times 10 constant current monitor amplifier input from the high side of the sense resistor.  |
| 55         | CC2               | Gate drive to the current source Power FET.  |
| 56         | GNDD2             | Digital Ground.  |
| 57         | GND A2            | Analog Ground.   |
| 58         | VLOW2             | Filter capacitor for internally generated shunt Power FET gate lower drive voltage level (1μF).  |
| 59         | SG_2              | Drive output to shunt Power FET gate.  |
| 60         | VUP2              | Filter capacitor for internally generated shunt gate upper voltage level (1μF).  |
| 61         | V9P               | Filter capacitor bypass for internally generated 9V power source (1μF).  |
| 62         | RLY_OUT           | Relay output drive from an N-channel FET controls an external relay to switch the Laser power supply or power supply interlock ON/OFF for both Laser Drivers.      |
| 63         | RLY_IN            | Relay input control with 5V CMOS logic. A high switches on the relay. This pin has an internal pulldown.   |
| 64, 65     | ESD LASER PS-2    | Laser power supply ESD protection.   |
| 66, 67, 68 | ESD SHUNT DRAIN-2 | Laser diode ESD protection.  |

# HIP9022

## Absolute Maximum Ratings

|  |              |
|--|--------------|
| Maximum Analog Supply Voltage, $V_{DD}$  | -0.3V to 14V |
| Logic Supply Voltage, $V_{CC}$           | -0.3V to 6V  |
| Analog Negative Supply Voltage, $V_{EE}$ | 0.3V to -5.5 |
| Maximum Laser Protection Diode Current   | 10A, 200ns   |

## Operating Conditions

|   |                |
|---|----------------|
| $V_{DD}$ Supply Voltage Range, $V_{DD}$ | 11.4V to 12.6V |
| $V_{CC}$ Supply Voltage Range, $V_{CC}$ | 4.5V to 5.5V   |
| $V_{EE}$ Supply Voltage Range, $V_{EE}$ | -4.5V to -5.5V |
| Laser Power Supply Range, $V_{LAS}$     | 3V to 5V       |
| TEC Power Supply Range, $V_{TEC}$       | 3V to 5V       |
| Laser Operating Current Range, $I_{DL}$ | 0A to 2A       |
| TEC Operating Current Range, $I_{TEC}$  | 0A to 2A       |

**CAUTION:** Stresses above those listed in "Absolute Maximum Ratings" may cause permanent damage to the device. This is a stress only rating and operation of the device at these or any other conditions above those indicated in the operational sections of this specification is not implied.

## NOTE:

- $\theta_{JA}$  is measured with the component mounted on an evaluation PC board in free air.

## Thermal Information

|   |                      |
|---|----------------------|
| Thermal Resistance (Typical, Note 1)          | $\theta_{JC}$ (°C/W) |
| PLCC Package                                  | 40                   |
| Maximum Operating Junction Temperature, $T_J$ | 100°C                |
| Maximum Storage Temperature Range, $T_{STG}$  | -55°C to 150°C       |
| Maximum Lead Temperature (Soldering 10s)      | 300°C                |

## Die Characteristics

|                     |                       |
|---------------------|-----------------------|
| Back Side Potential | $-V_{EE}$ , Substrate |
|---------------------|-----------------------|

## Electrical Specifications $T_J = 100^\circ\text{C}$ , $V_{DD} = 12\text{V}$ , $V_{CC} = 5\text{V}$ , $V_{EE} = -5\text{V}$ , INVERT Low (Figure 1 Configuration) Unless Otherwise Specified

| PARAMETER  | SYMBOL      | TEST CONDITIONS                     | MIN  | TYP | MAX            | UNITS   |
|--|-------------|-------------------------------------|------|-----|----------------|---------|
| <b>POWER SUPPLIES</b>  |             |                                     |      |     |                |         |
| V9P Voltage, No External Load  | V9P         | 1 $\mu$ F Tantalum Capacitor to V9P | -    | 9   | -              | V       |
| V9P Thermal Shutdown   |             |                                     | 150  | -   | -              | °C      |
| V9P Thermal Shutdown Recovery  |             |                                     | -    | -   | 125            | °C      |
| V9P Current Limiting   |             |                                     | 65   | -   | -              | mA      |
| $V_{DD}$ Power Supply Current  | $I_{DD}$    |                                     | -    | 25  | 75             | mA      |
| $V_{CC}$ Power Supply Current  | $I_{CC}$    |                                     | -    | 1.5 | 25             | mA      |
| $V_{EE}$ Power Supply Current  | $I_{EE}$    |                                     | -75  | -23 | -              | mA      |
| <b>LOGIC/DIGITAL INPUTS</b> (A0-A3, NULLB and SB_H, LASERON1B, LASERON2B with 60k $\Omega$ Pullup Resistors; INVERT, RESETB, RLY_IN 60k $\Omega$ with Pulldown Resistors)  |             |                                     |      |     |                |         |
| Low Level Input Voltage  | $V_{IL}$    |                                     | 0    | -   | 1.5            | V       |
| High Level Input Voltage   | $V_{IH}$    |                                     | 3.5  | -   | $V_{CC} + 0.3$ | V       |
| Minimum Hysteresis   | $V_{HYS}$   |                                     | 0.3  | -   | -              | V       |
| Low Level Input Current (Inputs with Pullups)  | $I_{IL}$    |                                     | -140 | -   | -              | $\mu$ A |
| High Level Input Current (Inputs with Pulldowns)   | $I_{IH}$    |                                     | -    | -   | 140            | $\mu$ A |
| <b>CONSTANT CURRENT CONTROLLER</b>   |             |                                     |      |     |                |         |
| OTA Gate Drive Amp. (A2) Voltage Output Range  | $V_G$       |                                     | -4   | -   | $V_{CC}$       | V       |
| Current Monitor Amp. (A1) Gain   | $A_{VS}$    |                                     | 9.8  | 10  | 10.2           | -       |
| Current Monitor Amp. Differential Sense Input Range  | $V_{IN}$    |                                     | 0    | -   | 500            | mV      |
| Current Monitor Amp. Input Offset  | $V_{IO}$    |                                     | -5   | -   | 5              | mV      |
| Current Monitor Amp. Common Mode Input Range   | $V_{IC}$    |                                     | 0    | -   | 5              | V       |
| <b>SHUNT CURRENT SWITCH CONTROLLER</b> (Note 2) $V_{UPPER} = 2\text{V}$ , $V_{LOWER} = -1\text{V}$ , Gate Load = 5000pF, VUP1, 2; 1 $\mu$ F Filter Capacitor to GND, VLOW1, 2; 1 $\mu$ F Filter Capacitor to GND, Unless Otherwise Specified |             |                                     |      |     |                |         |
| Shunt Gate Output Rise/Fall time   | $t_R/t_F$   | 10% -90% Rise, 90% -10% Fall        | -    | -   | 20             | ns      |
| Propagation Delay, LASERONB1, 2 to SG_1, 2   | $t_D$       | $T_J = 100^\circ\text{C}$           | -    | 80  | 110            | ns      |
|  |             | $T_J = -25^\circ\text{C}$           | -    | 60  | 95             | ns      |
| Drive Output Voltage   | $V_{UPPER}$ |                                     | 0    | -   | $V_{CC}$       | V       |
|  | $V_{LOWER}$ |                                     | -4   | -   | $V_{CC}$       | V       |

## HIP9022

**Electrical Specifications**  $T_J = 100^\circ\text{C}$ ,  $V_{DD} = 12\text{V}$ ,  $V_{CC} = 5\text{V}$ ,  $V_{EE} = -5\text{V}$ , INVERT Low (Figure 1 Configuration)  
Unless Otherwise Specified **(Continued)**

| PARAMETER   | SYMBOL                    | TEST CONDITIONS            | MIN  | TYP | MAX            | UNITS         |
|---|---------------------------|----------------------------|------|-----|----------------|---------------|
| Driver Maximum Output Current                           | $I_{DRSW}$                |                            | -1   | -   | 1              | A             |
| Shunt Controller Switching Frequency                    | $f_{SC}$                  |                            | 0    | -   | 2.5            | MHz           |
| <b>ANALOG SAMPLE/HOLD AMPLIFIERS</b>                    |                           |                            |      |     |                |               |
| Low Level Input Voltage                                 | $V_{IL}$                  |                            | 0    | -   | 1.5            | V             |
| Low Level Input Current                                 | $I_{IL}$                  |                            | -140 | -   | -              | $\mu\text{A}$ |
| High Level Input Voltage                                | $V_{IH}$                  |                            | 3.5  | -   | $V_{CC} + 0.3$ | V             |
| Minimum Hysteresis                                      | $V_{HYS}$                 |                            | 0.3  | -   | -              | V             |
| Analog Input Voltage Range                              | $V_{IN}$                  |                            | 0    | -   | $V_{CC} - 0.2$ | V             |
| Minimum Sample/Hold Pulse Width                         |                           |                            | -    | 10  | -              | $\mu\text{s}$ |
| Droop Rate, Constant Current Addresses #'s 1, 2         |                           |                            | -    | -   | 0.006          | V/s           |
| Droop Rate, Other Addresses #'s 3 - 8                   |                           |                            | -    | -   | 0.06           | V/s           |
| Maximum Analog Multiplexing Frequency                   |                           |                            | -    | -   | 30             | kHz           |
| <b>DIAGNOSTIC OUTPUT</b> (DIAG Output)                  |                           |                            |      |     |                |               |
| Voltage Follower Voltage Range                          | $V_O$                     |                            | 0    | -   | $V_{CC} - 0.2$ | V             |
| Voltage Follower Maximum Clamp Voltage                  | $V_{CL}$                  |                            | -    | -   | $V_{CC} + 0.3$ | V             |
| <b>O. C. (OVER CURRENT) COMPARATOR</b> (OC1, 2 Outputs) |                           |                            |      |     |                |               |
| Threshold (%) O.C. Detection                            |                           | Programmed Current as Ref. | -    | 140 | -              | %             |
| Output Voltage, Low Level                               | $V_{OL}$                  |                            | 0    | -   | 1.5            | V             |
| Output Current, Low Level                               | $I_{OL}$                  |                            | -    | 12  | -              | mA            |
| Output Voltage, High Level                              | $V_{OH}$                  |                            | 3.5  | -   | $V_{CC} - 0.5$ | V             |
| Output Current, High Level                              | $I_{OH}$                  |                            | -    | 4   | -              | mA            |
| <b>TEC REF. RESISTOR AND DRIVE OUTPUT</b>               |                           |                            |      |     |                |               |
| TECREFR Output Voltage to Reference Resistor            | $V_{REFR}$                |                            | 1.71 | 1.9 | 2.09           | V             |
| TECGDR1, 2 Drive Output Voltage                         | $V_{TECG}$                |                            | 0    | -   | 9              | V             |
| <b>OVER/UNDER TEMPERATURE COMPARATOR</b> (To OT Output) |                           |                            |      |     |                |               |
| Under Temp. Limit                                       | $T_{LOW}$                 |                            | 2.07 | 2.1 | 2.13           | V             |
| Over Temp. Limit  | $T_{HIGH}$                |                            | 1.67 | 1.7 | 1.73           | V             |
| Output Voltage, Low Level                               | $V_{OL}$                  |                            | 0    | -   | 1.5            | V             |
| Output Current, Low Level                               | $I_{OL}$                  |                            | -    | 12  | -              | mA            |
| Output Voltage, High Level                              | $V_{OH}$                  |                            | 3.5  | -   | $V_{CC} - 0.5$ | V             |
| Output Current, High Level                              | $I_{OH}$                  |                            | -    | 4   | -              | mA            |
| <b>RELAY DRIVER</b>                                     |                           |                            |      |     |                |               |
| Driver Output Current                                   | $I_{RLY}$                 |                            | -    | -   | 30             | mA            |
| Drain to Source Resistance                              | $r_{DS(ON)}$              |                            | -    | 20  | -              | $\Omega$      |
| <b>LASER PROTECTION DIODES</b> See Figure 1             |                           |                            |      |     |                |               |
| Maximum Diode Forward Voltage Drop                      | $V_{LDX}$ ,<br>$V_{ESDX}$ | 10A Peak Current           | -    | -   | 2              | V             |
| Maximum Reverse Diode Current                           | $I_{LDX}$                 |                            | -    | -   | 1              | $\mu\text{A}$ |

NOTE:

- The drive control sets the high and low voltages to the gate of the Power FET driver (shunt switch). Both the upper and lower levels are set by values held in two of the sample/hold amplifiers. External capacitors at VUP1, 2 and VLOW1, 2 are required for stabilization.

# HIP9022

## Address, Timing and Waveforms

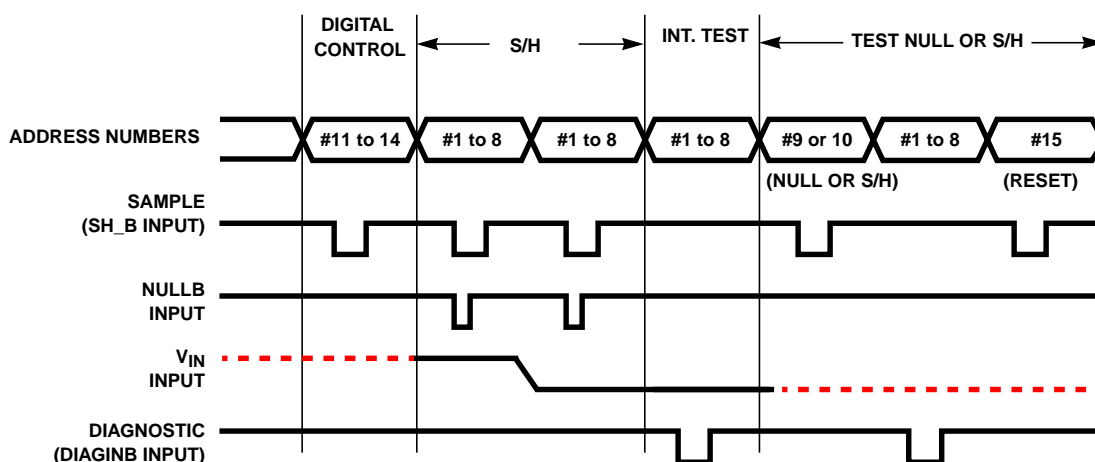

FIGURE 2. ADDRESS WITH SAMPLE, NULL,  $V_{IN}$  AND DIAGONAL WAVEFORMS

TABLE 1. HIP9022 ADDRESS MAP

| A3 | A2 | A1 | A0 | ADDRESS NO. | FUNCTION TYPE | FUNCTION NAME  |
|----|----|----|----|-------------|---------------|--|
| 0  | 0  | 0  | 0  | 1           | ANALOG        | $V_{IN(DL)}$ Voltage for Constant Current Level, Laser Driver #1   |
| 0  | 0  | 0  | 1  | 2           | ANALOG        | $V_{IN(DL)}$ Voltage for Constant Current Level, Laser Driver #2   |
| 0  | 0  | 1  | 0  | 3           | ANALOG        | $V_{LOWER}$ Level, Laser Driver #1                                 |
| 0  | 0  | 1  | 1  | 4           | ANALOG        | $V_{LOWER}$ Level, Laser Driver #2                                 |
| 0  | 1  | 0  | 0  | 5           | ANALOG        | $V_{UPPER}$ Level, Laser Driver #1                                 |
| 0  | 1  | 0  | 1  | 6           | ANALOG        | $V_{UPPER}$ Level, Laser Driver #2                                 |
| 0  | 1  | 1  | 0  | 7           | ANALOG        | $V_{IN(DL)}$ Thermal Compensation Level, Laser Driver #1           |
| 0  | 1  | 1  | 1  | 8           | ANALOG        | $V_{IN(DL)}$ Thermal Compensation Level, Laser Driver #2           |
| 1  | 0  | 0  | 0  | 9           | DIGITAL       | Test Mode: S/H Amp, Auto Zero Null Voltage (Note 4)                |
| 1  | 0  | 0  | 1  | 10          | DIGITAL       | Test Mode: S/H Amp Output Voltage (Note 4)                         |
| 1  | 0  | 1  | 0  | 11          | DIGITAL       | Test Mode: Set $V_{UP}$ and $V_{LOW}$ Amps to Three-State (Note 4) |
| 1  | 0  | 1  | 1  | 12          | DIGITAL       | $V_{LOW\#1}$ Set to Positive Output (Default is Negative)          |
| 1  | 1  | 0  | 0  | 13          | DIGITAL       | $V_{LOW\#2}$ Set to Positive Output (Default is Negative)          |
| 1  | 1  | 0  | 1  | 14          | DIGITAL       | Thermal Compensation Activated (Default is Deactivated)            |
| 1  | 1  | 1  | 0  | 15          | DIGITAL       | Reset Digital Address (9-14) to Default State                      |
| 1  | 1  | 1  | 1  | 16          | DIGITAL       | Idle Condition (S/H Pin Defeated) (Note 3)                         |

### NOTES:

- The Idle address is protective in that SB\_H input noise cannot disturb the chip if the Idle address is selected; also, the Address inputs are High (selecting Idle state) if the pins are open.
- Address Numbers 9 - 11 are shaded to indicate test mode conditions and are shown for information only. These addresses are used in original production testing and not required for user applications. However, note that Address No. 15 will force a reset for Address Numbers 9 - 14.
- Digital Programming: To set the digital addresses, only the proper digital address and a negative pulse >100ns on SB\_H is needed. To reset the digital addresses to the default states, Address 15 and a SB\_H pulse >100ns is needed. Normally the digital addresses will be set first, and the analog addresses programmed next. The test modes, Address Numbers 9 - 11, will normally only be used during factory testing. An address 15 Reset should normally precede most programming in order to assure that the digital address states begin in their default state. Otherwise, the digital address states will be undefined because there is no power-up-reset.
- Analog Programming: To program the eight S/H circuits, addresses of 0-5V analog signal on  $V_{IN}$  and negative pulses on NullB (10 $\mu$ s) and SB\_H (20 $\mu$ s) pins are needed. The NullB pulse is valid only during the SB\_H pulse and should occur during the first half of the SB\_H pulse. The S/H amplifier is auto-zeroed for zero offset when both NullB and SB\_H are low. The input  $V_{IN}$  is captured on the S/H storage capacitor during SB\_H low.
- The Diagnostic mode reads map addresses 1 - 8 via the DIAG output when DIAGINB is low.

**Circuit Block Descriptions**

**Laser Drive Circuitry**

In Figure 3, the gate of the external current source Power FET, Q2 is driven via the Operational Transconductance Amplifier (OTA), A2 on the IC. The voltage on the current sense resistor,  $R_S$  in the source of the Power FET is monitored by a X10 gain of the feedback amplifier, A1. The stability of the current loop is established with an external 0.1 $\mu$ F capacitor to ground at the gate of the Power FET. The sampled voltage range is 0 to 0.5V when the proper value of sense resistor,  $R_S$  is chosen (typically 0.25 $\Omega$  for 2A). The OTA, A2 compares the X10 gain signal to a 0 to 5V reference signal from an on-chip Sample and Hold (First S/H) circuit. The Q2 drain current (Laser Drive current),  $I_{DL}$  is:

$$I_{DL} = \frac{V_{IN(DL)}}{(R_S \times 10)} \quad (\text{EQ. 1})$$

where  $V_{IN(DL)}$  is the programmed  $V_{IN}$  for the First S/H voltage reference signal.

The S/H reference for the Laser Drive Current current is updated with other multiplexed S/H circuits from a serial bus and an off-chip D/A converter. Laser constant current is fully controllable by the multiplex analog S/H bus, allowing accurate calibration of the laser output and corrections as the laser ages.

In Figure 1, the laser drive current from Q2 is digitally switched to either flow through or is shunted around the laser diode by switching the external Shunt Power FET, Q3 on or off. The gate of the Shunt FET is switched between two voltages (Upper and Lower) which are provide by 2nd and 3rd S/H circuits. These Shunt FET gate drive levels are fully programmable via the multiplexed analog S/H bus. By adjusting these levels to account for the laser power supply, the Shunt FET threshold and channel resistance; minimum Shunt FET gate drive power levels can be established. The Upper and Lower gate voltage driver circuits are two high current OTA amplifiers with two filter capacitors. The upper voltage is programmable in the 0V to  $V_{CC}$  range at the input of amplifier A4. The lower voltage is programmable in the range of -4V to  $V_{CC}$ . The -4V extension is accomplished by an optional on-chip voltage inverter circuit. The input to amplifier A3 is either direct from the S/H input or inverted by amplifier A5.

The maximum laser on-off switching speeds are dependent on the selection of Shunt FETs. A Harris dual complementary MOSFET, RF3V49092 or RF3S49092 has been designed specifically for this application. With the constant current set at 0.8A, a typical laser switching speed of 20ns has been measured.

**Thermal Compensation**

A 4th S/H circuit is used to set the amplitude of an optional thermal compensation signal which can be used to modulate the constant laser current source as a two pole filtered effect of the laser on-off data. This feature may be disabled when it is not required. This circuit is designed to compensate for the temperature variations in the laser as the laser is turned on and off. The bypass capacitors at the Thermal Comparator (CTCx-10K, CTCx-27K) represent the respective poles for the filter.

A laser cools after it has been off for a period of time and is more efficient when it is turned-on. Compensation for the increased efficiency is made by slightly reducing the current level of the constant current source FET. The level will be reduced by a programmable amount of 0 to 5% of full scale. The programmable amount is fixed by the level of compensation to S/H addresses 7 and 8 (see Table 1). The percent of modulation (change) in drive current is calculated as follows:

$$\text{Modulation \%} = \frac{V_{IN(TC)}}{V_{IN(DL)}} \times 5\% \quad (\text{EQ. 2})$$

For example, if we control the Laser Drive current with 2V programmed with address 1 and 2 for the First S/H's, given that  $V_{IN(DL)} = 2V$  and  $R_S = 0.25\Omega$ . Then, from EQ. 1,  $I_{DL} = V_{IN(DL)} / (R_S \times 10) = 2 / (0.25 \times 10) = 0.8A$ .

If 2V is programmed to addresses 7 and 8 as Thermal Compensation,  $V_{IN(TC)}$  for the 4th S/H's, then,  $\text{Mod.\%} = (2/2) \times 5\% = 5\%$ .

In Figure 3, the correction is applied from the output of the Thermal Compensation circuit (where the current is  $2V/20k\Omega = 0.1mA$ ) to the input of amplifier A2. The 0.1mA is forced into the 1k $\Omega$  resistor (and the low Z output of A1) to increase the voltage at the inverting input of A2 by 0.1V or 5% of the + $V_{IN(DL)}$  input (2V) to A2. The modulation input is limited by the 0 to  $V_{CC}$  input range of S/H maximum  $V_{IN}$ .

**Input Data**

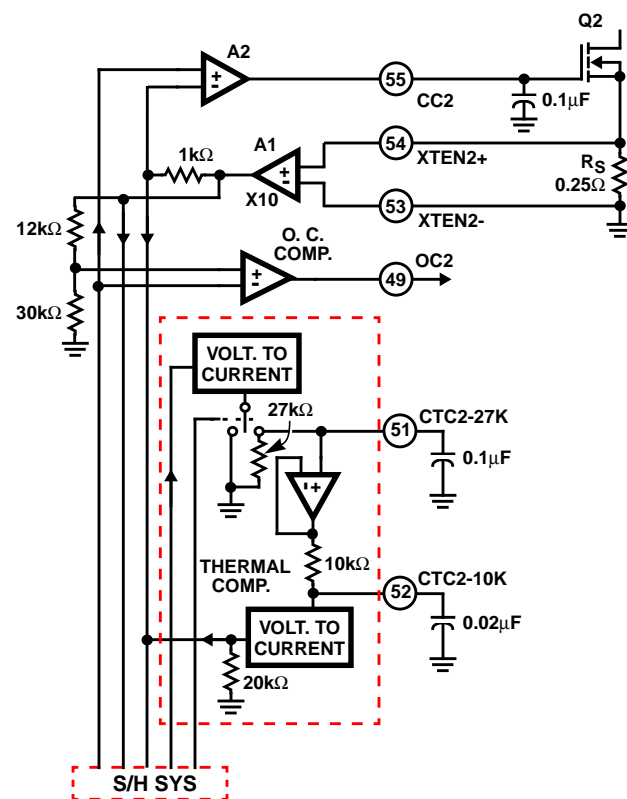

**FIGURE 3. LASER CONSTANT CURRENT SOURCE DRIVER WITH OVER CURRENT DETECTION AND THERMAL COMPENSATION**



Both analog and digital data is input to control the action of the dual laser driver. Address codes and input data are described in the Table 1 Address Map. Digital data is normally entered first, followed by the analog data via the multiplexed analog bus which updates the S/H stored voltage levels. Four bit digital addresses to pins A3, A2, A1 and A0 are decoded to define the programming functions for data input. It is important to note that Address 15 is a reset for Addresses 9 - 14 and should be performed as the first step in programming because there is no power-on-reset on-chip.

**Diagnostic Output Data**

For the purpose of monitoring on-chip signals, the multiplexed bus can be used to output signals (at the DIAG pin) via an analog diagnostic amplifier. This mode has the capability to monitor the multiplexed output of four (0-5V) analog signals for each laser channel. Note that the diagnostic information at the VLOW (Amplifier A3) output is 2:1 resistor divided to +5V (V<sub>CC</sub>) to return this signal to a 0 to 5V range. To minimize noise problems the monitoring function is normally performed during the laser scan for only one signal per scan. In addition, there are 3 test modes which allows the bus to present analog signals for testing the performance of the eight S/H circuits.

**Thermo-Electric-Cooler (TEC) Circuitry**

Figure 4 shows the Thermal Electric Cooler (TEC) drive circuit with an external reference resistance, a thermo-resistor to sense temperature plus feedback components for stable drive. There is a thermo-resistor reference input on the chip for monitoring the laser's temperature via a 5-10kΩ thermo-resistor which must be mounted near the laser. A reference voltage on the external reference resistor is established by a current from a stable bias source. This current is mirrored to the thermo-resistor (one for each laser driver system). A comparator senses the voltage across the reference resistor versus the voltage across the thermo-

resistor and drives the gate of the TEC FET driver. As such, the TEC circuit senses the thermo-resistor input as a measure of the laser temperature and the TEC drive is adjusted to maintain a stable Laser temperature slightly below the ambient temperature. An external Power FET is needed to provide the high TEC driver currents. An out of range temperature output for each laser is also provided.

**Laser Protection Diodes**

Another feature included on the chip is two high current ESD diodes which, in the printer system, are used to protect the Laser Diodes from ESD damage. Another component of Laser protection in printer systems are relays to disconnect the Lasers when in a non-operating mode. For this purpose, a single relay driver is included.

**Over Current Flag Output (OC1, OC2)**

Over-current detection is also included on-chip. The circuit of Figure 3 shows the over current detection circuit. For each laser source current driver, the over current monitor compares the S/H input of amplifier A2 to the output of amplifier A1. If the output voltage of A1 exceeds the input of A2 by 40%, then an over current state exists and the OC output will go high.

**Invert Option**

An INVERT input reconfigures the device such that the constant current source can be high side instead of the normal low side. This provides functionality for driving laser diodes in a common cathode configuration as opposed to the normal common anode configuration. The INVERT must be low (or open with the internal pull down) for the Figure 1 circuit.

**Reset Action**

- The RESETB (active low) controls three things:
- (1) The TEC driver is turned off.
  - (2) The Shunt driver is turned on to turn off the laser.
  - (3) The Constant current driver is turned off.

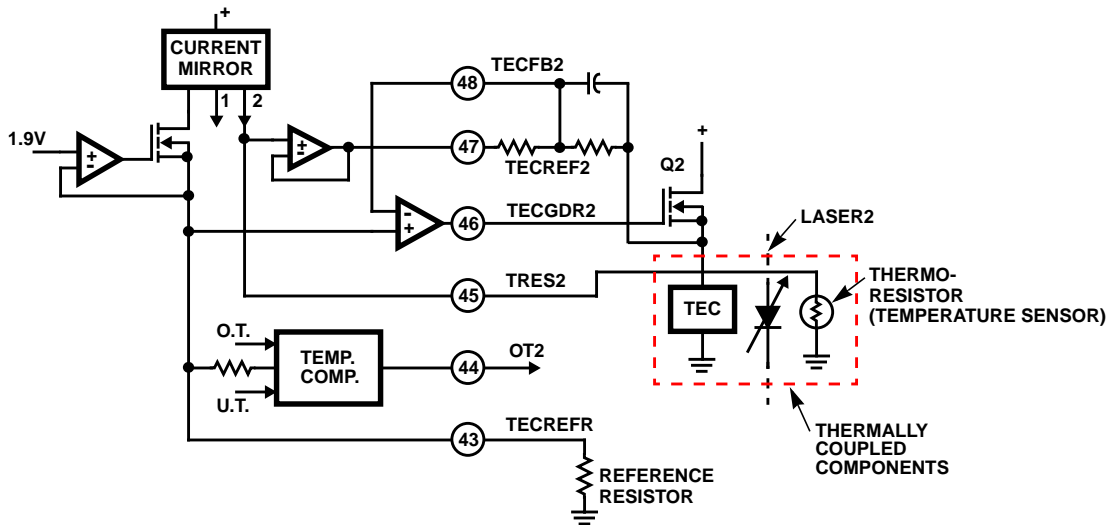

**FIGURE 4. TEC (THERMAL ELECTRIC COOLER) CIRCUIT WITH REFERENCE RESISTOR AND THERMAL RESISTOR SENSOR OF LASER TEMPERATURE**

# HIP9022

## Plastic Leaded Chip Carrier Packages (PLCC)

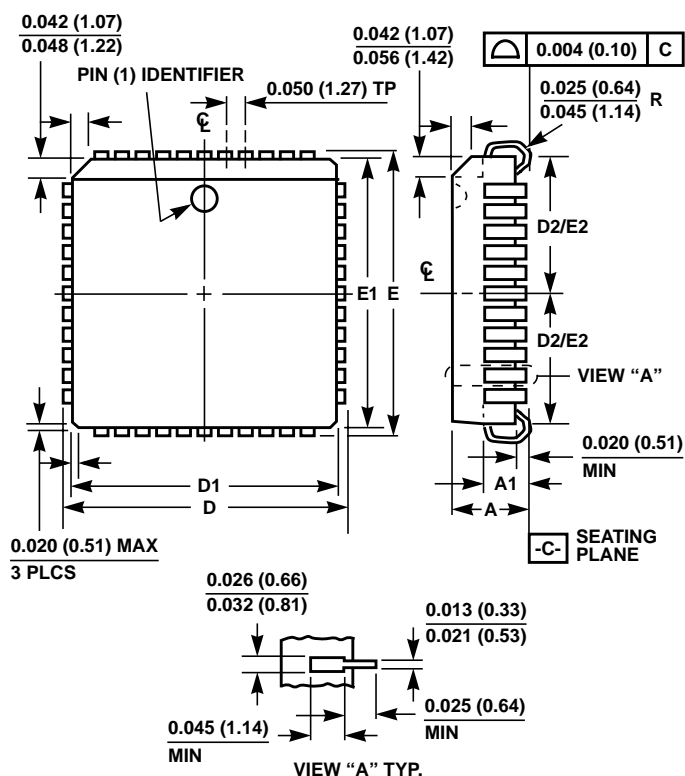

### N68.95 (JEDEC MS-018AE ISSUE A) 68 LEAD PLASTIC LEADED CHIP CARRIER PACKAGE

| SYMBOL | INCHES |       | MILLIMETERS |       | NOTES |
|--------|--------|-------|-------------|-------|-------|
|        | MIN    | MAX   | MIN         | MAX   |       |
| A      | 0.165  | 0.180 | 4.20        | 4.57  | -     |
| A1     | 0.090  | 0.120 | 2.29        | 3.04  | -     |
| D      | 0.985  | 0.995 | 25.02       | 25.27 | -     |
| D1     | 0.950  | 0.958 | 24.13       | 24.33 | 3     |
| D2     | 0.441  | 0.469 | 11.21       | 11.91 | 4, 5  |
| E      | 0.985  | 0.995 | 25.02       | 25.27 | -     |
| E1     | 0.950  | 0.958 | 24.13       | 24.33 | 3     |
| E2     | 0.441  | 0.469 | 11.21       | 11.91 | 4, 5  |
| N      | 68     |       | 68          |       | 6     |

Rev. 2 11/97

#### NOTES:

1. Controlling dimension: INCH. Converted millimeter dimensions are not necessarily exact.
2. Dimensions and tolerancing per ANSI Y14.5M-1982.
3. Dimensions D1 and E1 do not include mold protrusions. Allowable mold protrusion is 0.010 inch (0.25mm) per side. Dimensions D1 and E1 include mold mismatch and are measured at the extreme material condition at the body parting line.
4. To be measured at seating plane [-C-] contact point.
5. Centerline to be determined where center leads exit plastic body.
6. "N" is the number of terminal positions.

All Intersil semiconductor products are manufactured, assembled and tested under **ISO9000** quality systems certification.

*Intersil semiconductor products are sold by description only. Intersil Corporation reserves the right to make changes in circuit design and/or specifications at any time without notice. Accordingly, the reader is cautioned to verify that data sheets are current before placing orders. Information furnished by Intersil is believed to be accurate and reliable. However, no responsibility is assumed by Intersil or its subsidiaries for its use; nor for any infringements of patents or other rights of third parties which may result from its use. No license is granted by implication or otherwise under any patent or patent rights of Intersil or its subsidiaries.*

For information regarding Intersil Corporation and its products, see web site <http://www.intersil.com>

### Sales Office Headquarters

#### NORTH AMERICA

Intersil Corporation  
P. O. Box 883, Mail Stop 53-204  
Melbourne, FL 32902  
TEL: (407) 724-7000  
FAX: (407) 724-7240

#### EUROPE

Intersil SA  
Mercure Center  
100, Rue de la Fusee  
1130 Brussels, Belgium  
TEL: (32) 2.724.2111  
FAX: (32) 2.724.22.05

#### ASIA

Intersil (Taiwan) Ltd.  
7F-6, No. 101 Fu Hsing North Road  
Taipei, Taiwan  
Republic of China  
TEL: (886) 2 2716 9310  
FAX: (886) 2 2715 3029