

INTELLIGENT POWER LOW SIDE SWITCH

Features

- Over temperature shutdown
- Over current shutdown
- Active clamp
- Low current & logic level input
- ESD protection
- Optimized Turn On/Off for EMI
- Diagnostic on the input current

Product Summary

| | |
|-----------|-------------|
| Rds(on) | 13mΩ (max.) |
| Vclamp | 36V |
| Ishutdown | 85A (typ.) |

Description

The IPS1011(S)(R) is a three terminal Intelligent Power Switch (IPS) that features a low side MOSFET with over-current, over-temperature, ESD protection and drain to source active clamp. This device offers protections and the high reliability required in harsh environments. The switch provides efficient protection by turning OFF the power MOSFET when the temperature exceeds 165°C or when the drain current reaches 85A. The device restarts once the input is cycled. A serial resistance connected to the input provides the diagnostic. The avalanche capability is significantly enhanced by the active clamp and covers most inductive load demagnetizations.

Packages

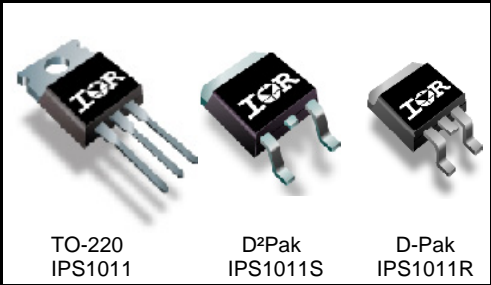

Typical Connection

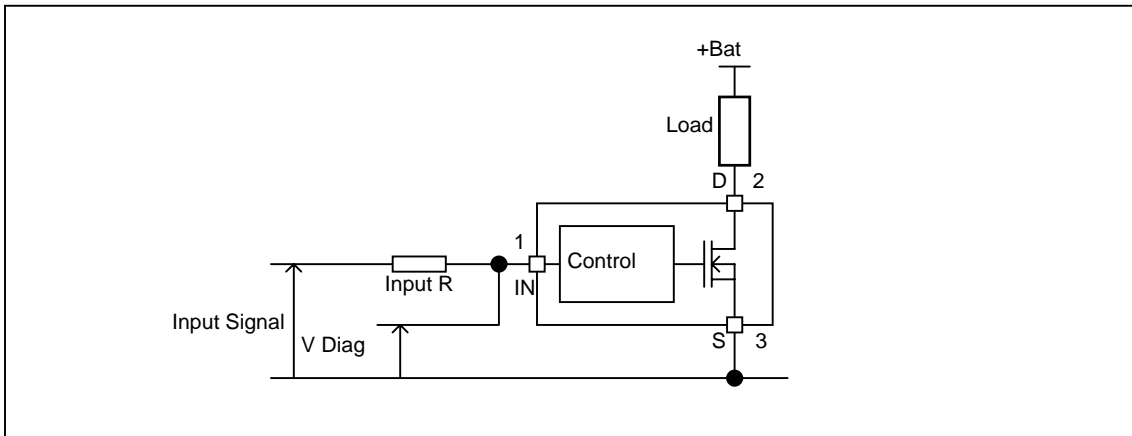

Absolute Maximum Ratings

Absolute maximum ratings indicate sustained limits beyond which damage to the device may occur. All voltage parameters are referenced to Ground lead. (Tambient=25°C unless otherwise specified).

| Symbol | Parameter | Min. | Max. | Units |
|---------------------------------------|--|------|------|-------|
| Vds | Maximum drain to source voltage | -0.3 | 36 | V |
| Vds cont. | Maximum continuous drain to source voltage | - | 28 | V |
| Vin | Maximum input voltage | -0.3 | 6 | V |
| Isd cont. | Max diode continuous current (limited by thermal dissipation) | — | 5 | A |
| Pd | Maximum power dissipation (internally limited by thermal protection) | | | |
| | Rth=5°C/W IPS1011 | — | 25 | W |
| | Rth=40°C/W IPS1011S 1" sqr. footprint | — | 3.1 | |
| Rth=50°C/W IPS1011R 1" sqr. footprint | — | 2.5 | | |
| ESD | Electrostatic discharge voltage (Human body) C=100pF, R=1500Ω | | | kV |
| | Between drain and source | — | 4 | |
| | Other combinations | — | 3 | |
| | Electrostatic discharge voltage (Machine Model) C=200pF, R=0Ω | | | |
| | Between drain and source | — | 0.5 | |
| | Other combinations | — | 0.3 | |
| Tj max. | Max. storage & operating temperature junction temperature | -40 | 150 | °C |
| Tsoldering | Lead soldering temperature (10 seconds) | — | 300 | °C |

Thermal Characteristics

| Symbol | Parameter | Typ. | Max. | Units |
|--------|--|------|------|-------|
| Rth1 | Thermal resistance junction to ambient IPS1011 TO-220 free air | 50 | — | °C/W |
| Rth2 | Thermal resistance junction to case IPS1011 TO-220 | 1.2 | — | |
| Rth1 | Thermal resistance junction to ambient IPS1011S D ² Pak std. footprint | 60 | — | |
| Rth2 | Thermal resistance junction to ambient IPS1011S D ² Pak 1" sqr. footprint | 40 | — | |
| Rth3 | Thermal resistance junction to case IPS1011S D ² Pak | 1.2 | — | |
| Rth1 | Thermal resistance junction to ambient IPS1011R D-Pak std. footprint | 70 | — | |
| Rth2 | Thermal resistance junction to ambient IPS1011R D-Pak 1" sqr. footprint | 50 | — | |
| Rth3 | Thermal resistance junction to case IPS1011R D-Pak | 1.2 | — | |

Recommended Operating Conditions

These values are given for a quick design. For operation outside these conditions, please consult the application notes.

| Symbol | Parameter | Min. | Max. | Units |
|------------|---|------|------|-------|
| VIH | High level input voltage | 4.5 | 5.5 | |
| VIL | Low level input voltage | 0 | 0.5 | |
| Ids | Continuous drain current, Tambient=85°C, Tj=125°C, Vin=5V | | | A |
| | Rth=5°C/W IPS1011 | — | 18 | |
| | Rth=40°C/W IPS1011S 1" sqr. Footprint | — | 6.5 | |
| | Rth=50°C/W IPS1011R 1" sqr. Footprint | — | 6 | |
| Rin | Recommended resistor in series with IN pin to generate a diagnostic | 0.5 | 10 | kΩ |
| Max L | Max recommended load inductance (including line inductance) (1) | — | 5 | μH |
| Max F | Max frequency (switching losses = conduction losses) | — | 200 | Hz |
| Max t rise | Max Input rising time | — | 1 | μs |

(1) Higher inductance is possible if maximum load current is limited - see figure 11

Static Electrical Characteristics

T_j=25°C, V_{cc}=14V (unless otherwise specified)

| Symbol | Parameter | Min. | Typ. | Max. | Units | Test Conditions |
|-----------------------|---|------|------|------|-------|--|
| R _{ds(on)} | ON state resistance T _j =25°C | — | 10 | 13 | mΩ | V _{in} =5V, I _{ds} =30A |
| | ON state resistance T _j =150°C (2) | — | 19 | 25 | | |
| I _{dss1} | Drain to source leakage current | — | 0.1 | 10 | μA | V _{cc} =14V, T _j =25°C |
| I _{dss2} | Drain to source leakage current | — | 0.2 | 20 | | V _{cc} =28V, T _j =25°C |
| V _{clamp1} | Drain to source clamp voltage 1 | 36 | 39 | — | V | I _d =20mA |
| V _{clamp2} | Drain to source clamp voltage 2 | — | 40 | 42 | | I _d =5A |
| V _{in clamp} | IN to source pin clamp voltage | 5.5 | 6.5 | 7.5 | | I _{in} =1mA |
| V _{th} | Input threshold voltage | — | 1.7 | — | | I _d =10mA |

Switching Electrical Characteristics

V_{cc}=14V, Resistive load=0.5Ω, R_{input}=50Ω, V_{in}=5V, T_j=25°C

| Symbol | Parameter | Min. | Typ. | Max. | Units | Test Conditions |
|------------------------------------|----------------------------|------|------|------|-------|-----------------|
| T _{don} | Turn-on delay time to 20% | 15 | 50 | 150 | μs | See figure 2 |
| T _r | Rise time 20% to 80% | 20 | 50 | 100 | | |
| T _{doff} | Turn-off delay time to 80% | 100 | 330 | 1000 | | |
| T _f | Fall time 80% to 20% | 30 | 70 | 150 | | |
| E _{on} + E _{off} | Turn on and off energy | — | 5 | — | mJ | |

Protection Characteristics

| Symbol | Parameter | Min. | Typ. | Max. | Units | Test Conditions |
|--------------------|---|--------|------|------|-------|---------------------|
| T _{sd} | Over temperature threshold | 150(2) | 165 | — | °C | See figure 1 |
| I _{sd} | Over current threshold | 60 | 85 | 110 | A | See figure 1 |
| OV | Over voltage protection (not active when the device is ON) | 34 | 37 | — | V | |
| V _{reset} | IN protection reset threshold | — | 1.7 | — | V | |
| T _{reset} | Time to reset protection | 15(2) | 50 | 200 | μs | V _{in} =0V |

Diagnostic

| Symbol | Parameter | Min. | Typ. | Max. | Units | Test Conditions |
|----------------------|---|------|------|------|-------|---------------------|
| I _{in, on} | ON state IN positive current | 15 | 32 | 70 | μA | V _{in} =5V |
| I _{in, off} | OFF state IN positive current (after protection latched) | 150 | 230 | 350 | | V _{in} =5V |

(2) Guaranteed by design

Lead Assignments

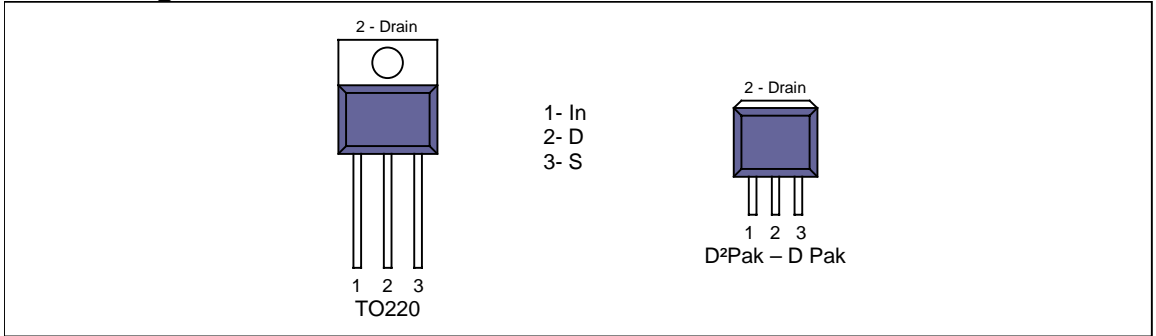

Functional Block Diagram

All values are typical

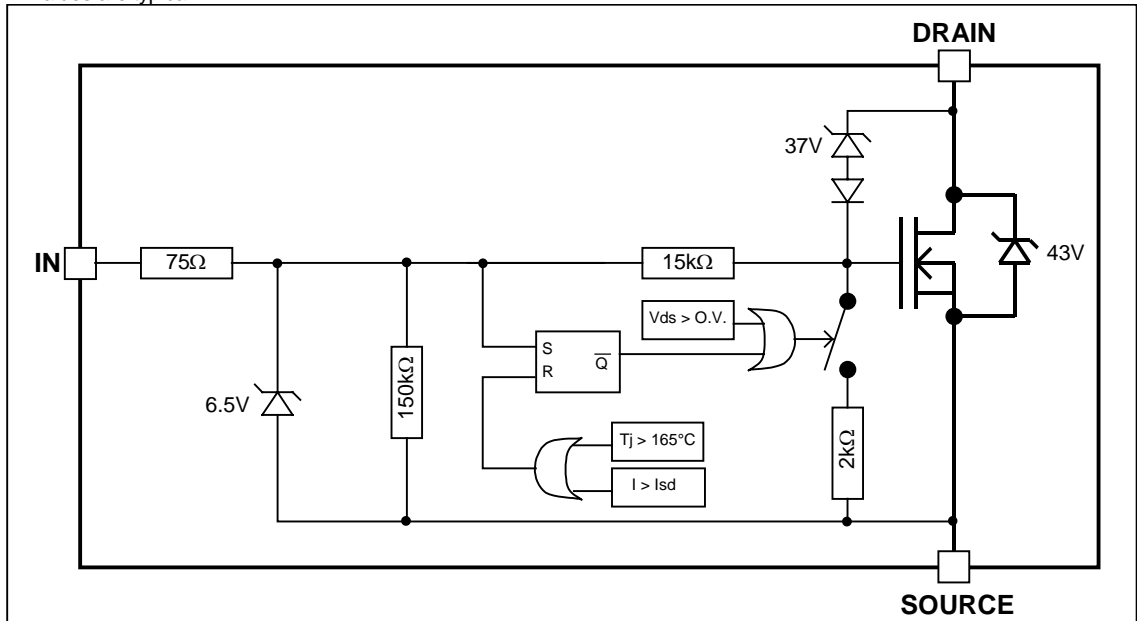

All curves are typical values. Operating in the shaded area is not recommended.

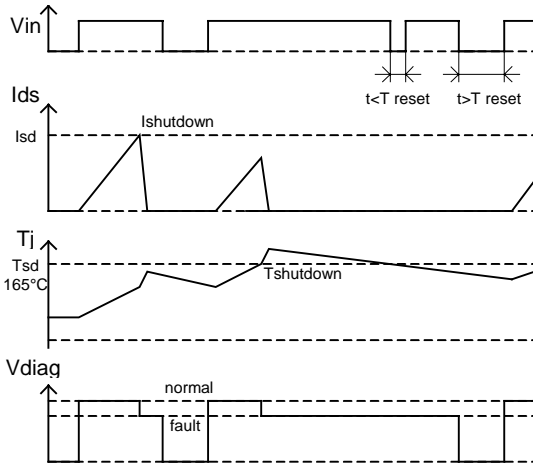

Figure 1 – Timing diagram

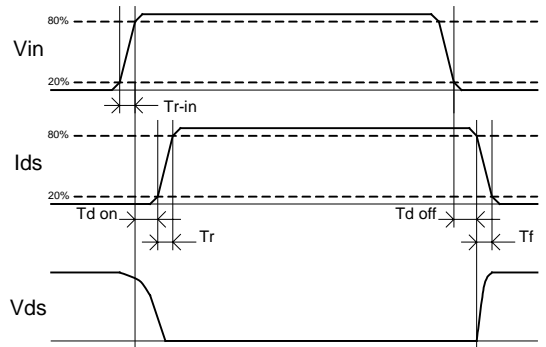

Figure 2 – IN rise time & switching definitions

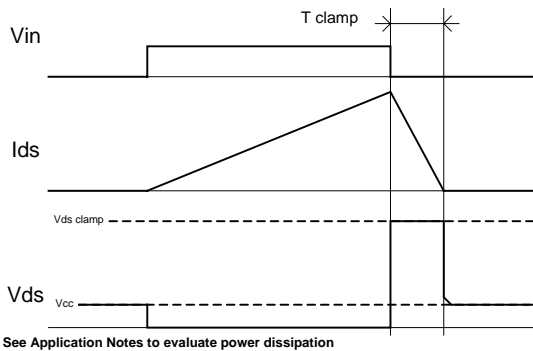

Figure 3 – Active clamp waveforms

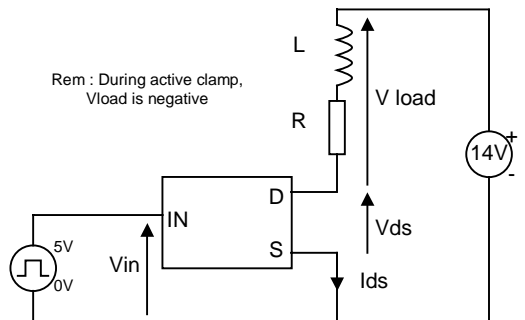

Figure 4 – Active clamp test circuit

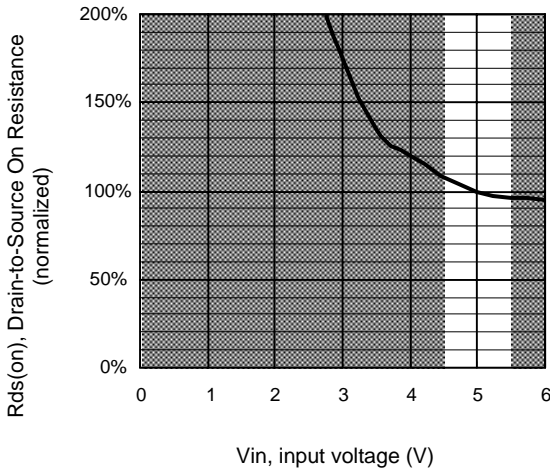

Figure 5 – Normalized R_{ds(on)} (%) Vs Input voltage (V)

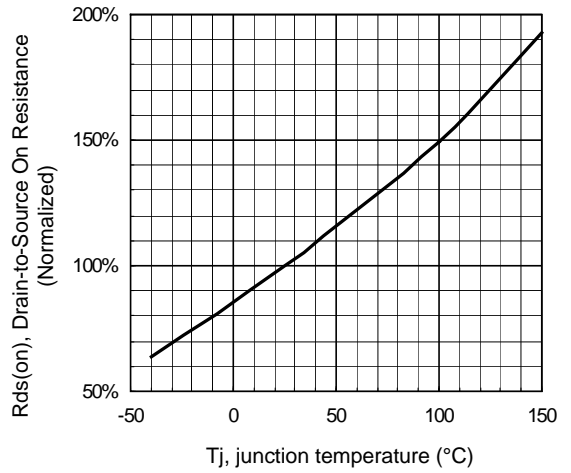

Figure 6 - Normalized R_{ds(on)} (%) Vs T_j (°C)

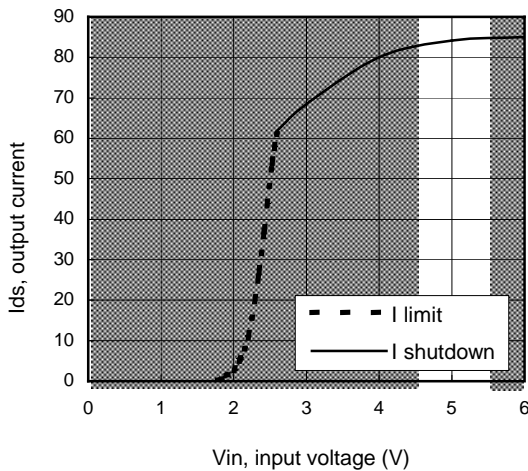

Figure 7 – Current limitation and current shutdown Vs Input voltage (V)

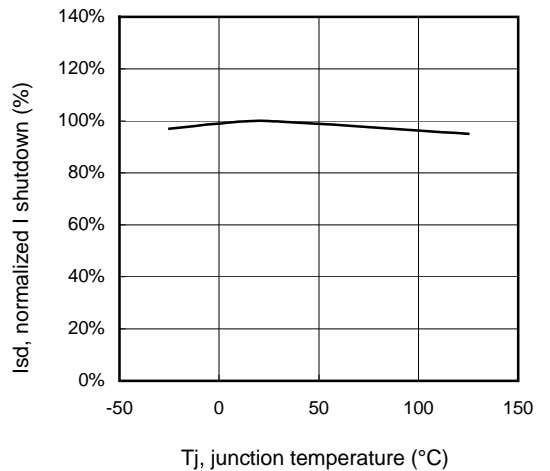

Figure 8 – Normalized I shutdown (%) Vs junction temperature (°C)

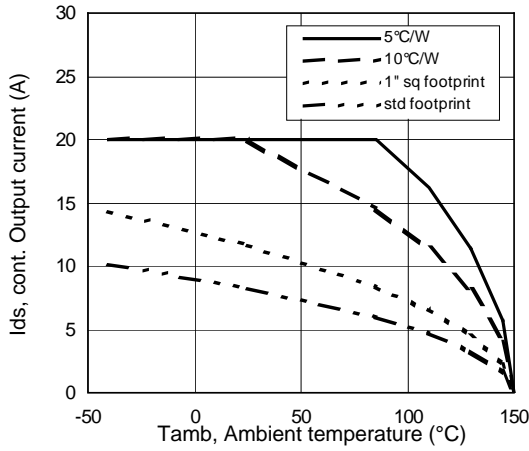

Figure 9 – Max. continuous output current (A) Vs Ambient temperature (°C)

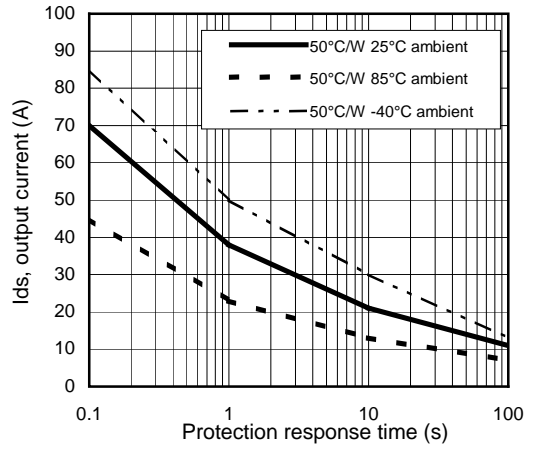

Figure 10 – Ids (A) Vs over temperature protection response time (s)

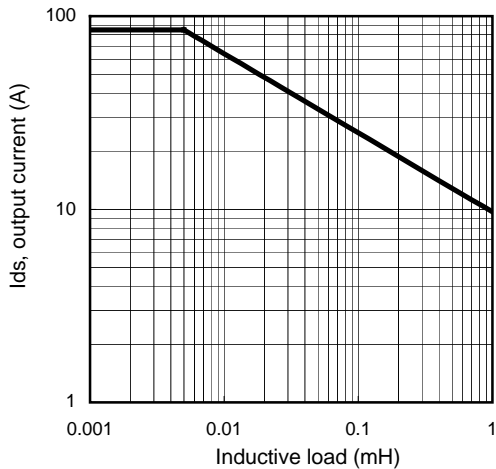

Figure 11 – Max. output current (A) Vs Inductive load (mH)

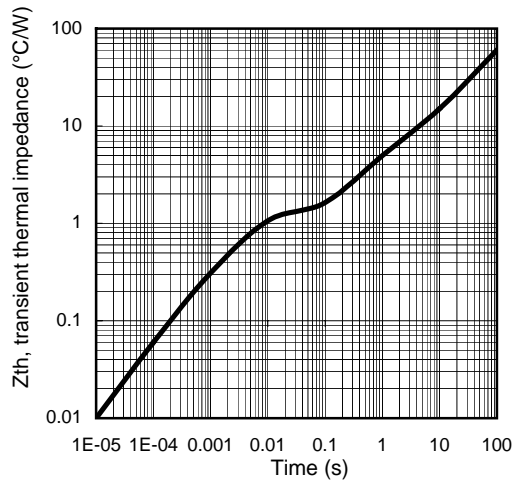

Figure 12 – Transient thermal impedance (°C/W) Vs time (s)

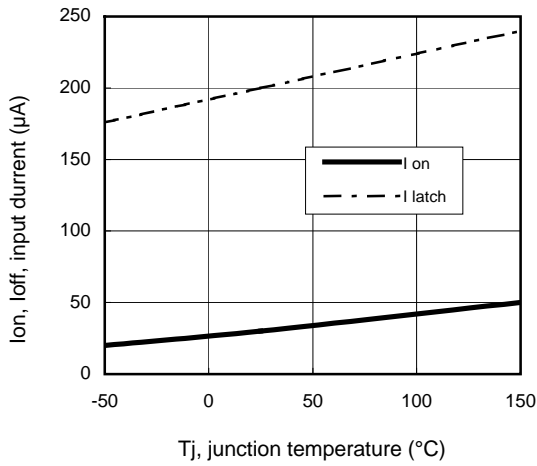

Figure 13 – Input current (µA) On and Off Vs junction temperature (°C)

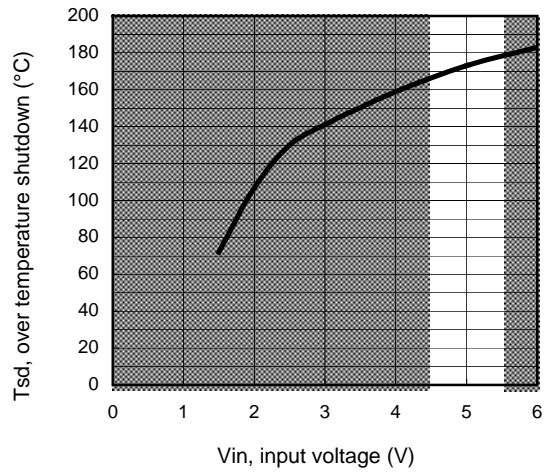
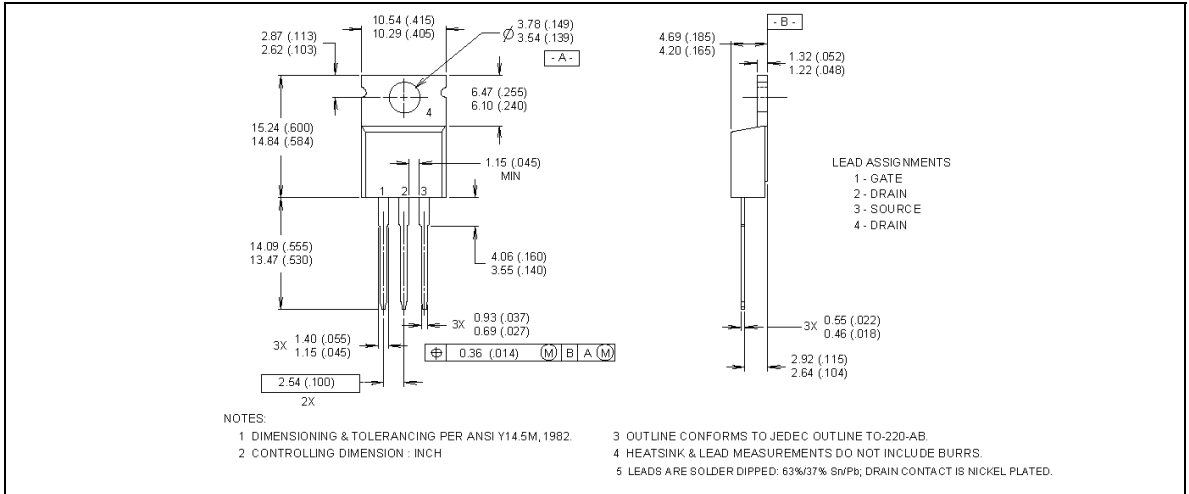
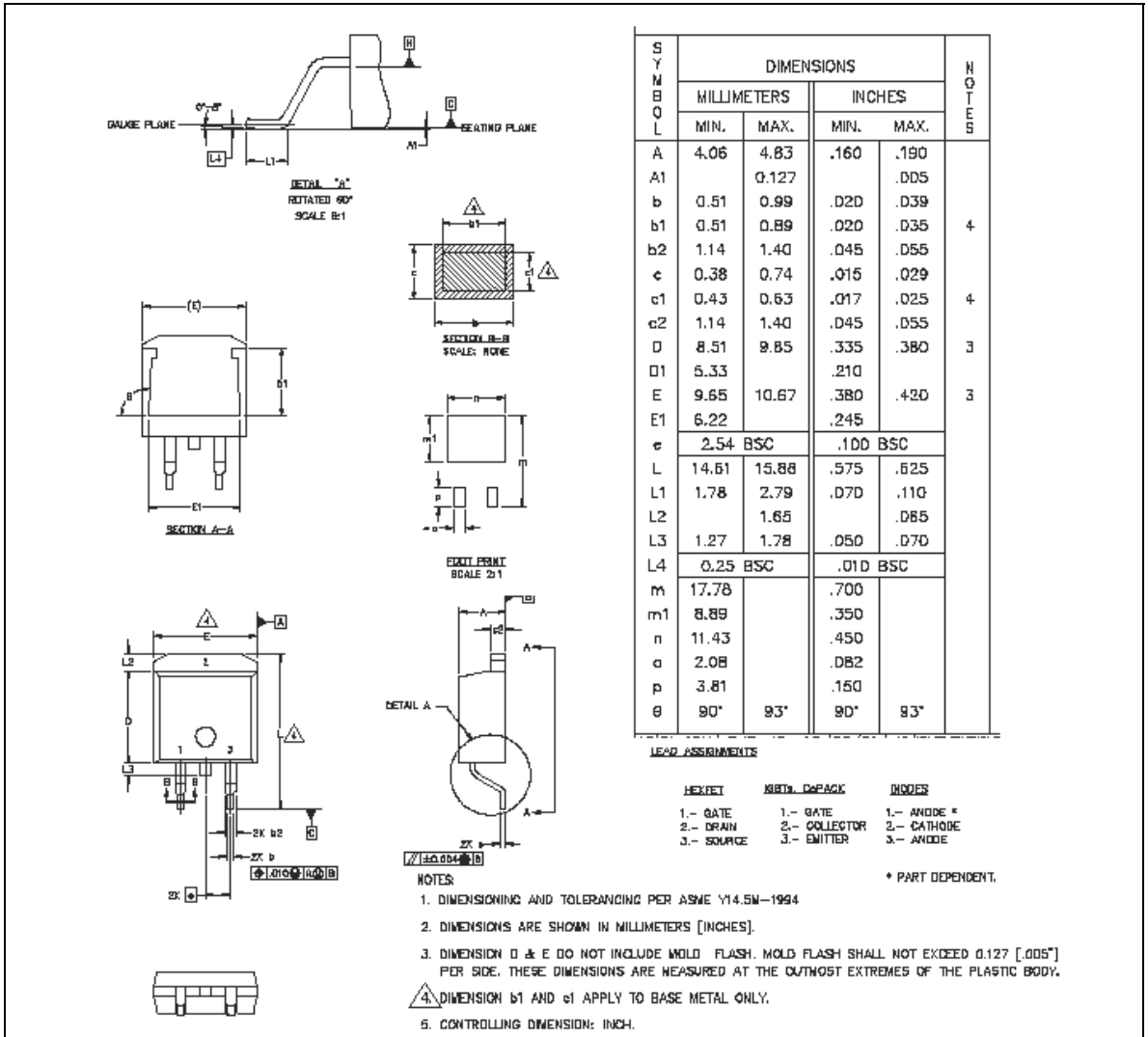

Figure 14 – Over temperature shutdown (°C) Vs input voltage (V)

Case Outline – TO-220 AB



Case Outline - D²Pak (SMD-220)



Case Outline – D-Pak

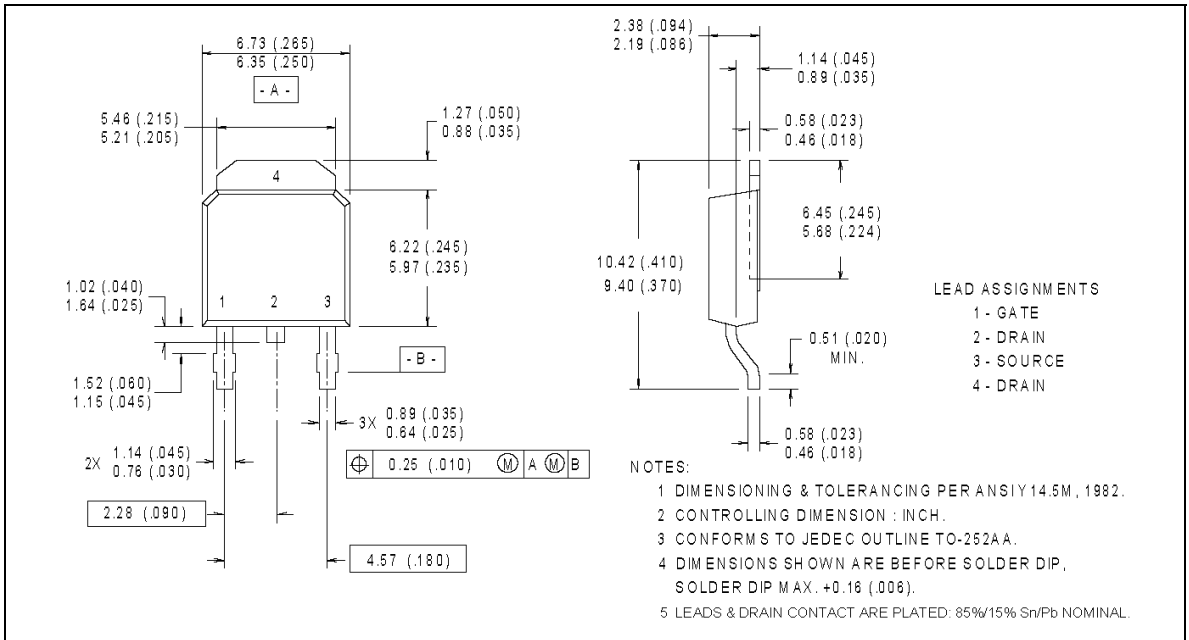

Tape & Reel - D²Pak (SMD220)

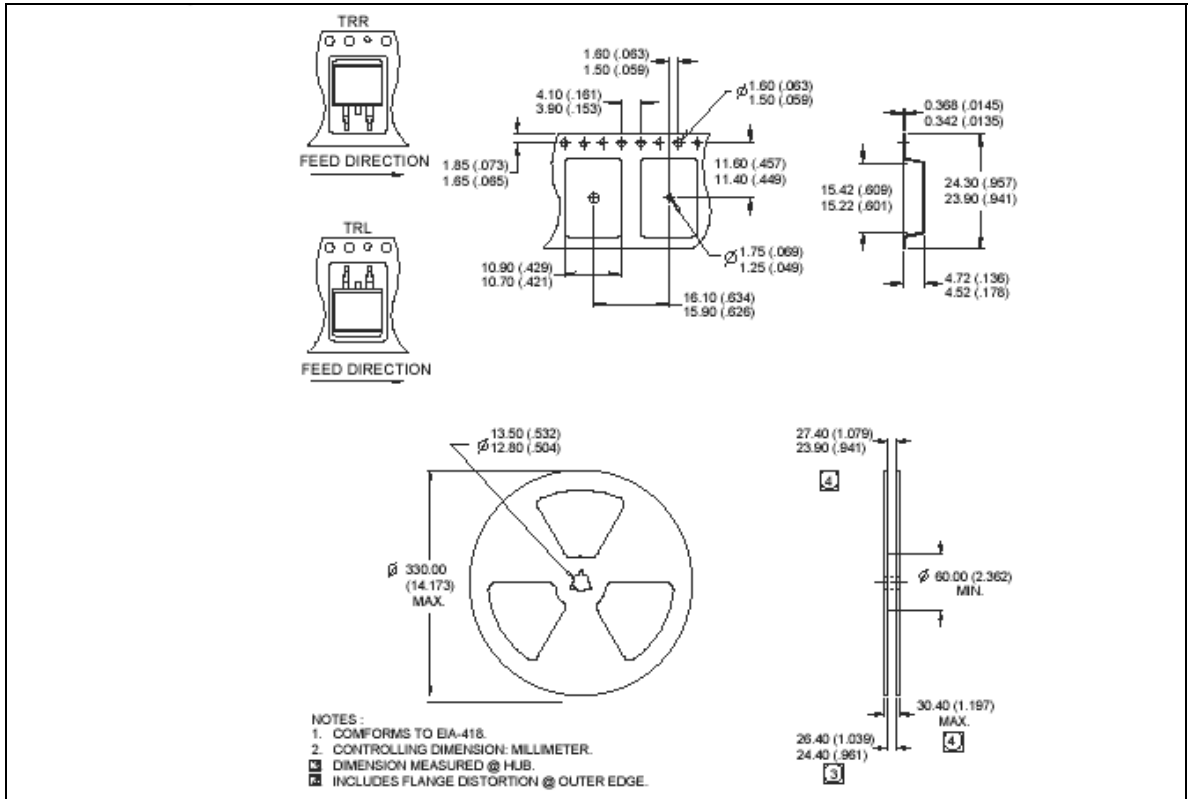

Tape & Reel - D-Pak

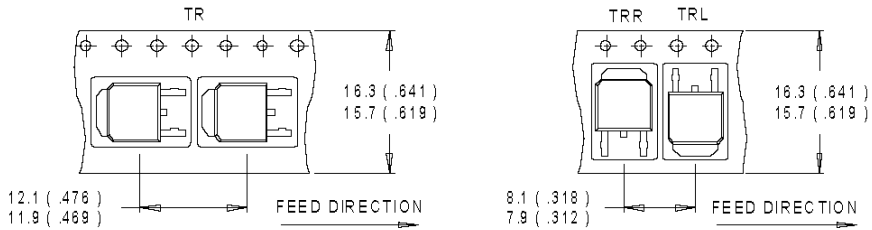

NOTES :

1. CONTROLLING DIMENSION : MILLIMETER.
2. ALL DIMENSIONS ARE SHOWN IN MILLIMETERS (INCHES).
3. OUTLINE CONFORMS TO EIA-481 & EIA-541.

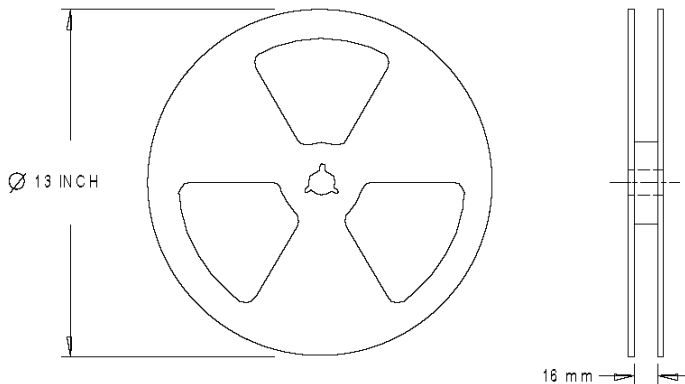

NOTES :

1. OUTLINE CONFORMS TO EIA-481.

Dimensions are shown in millimeters (inches)