

International IOR Rectifier

Data Sheet No. PD60168-D

IPS5551T

FULLY PROTECTED HIGH SIDE POWER MOSFET SWITCH

Features

- Over temperature shutdown
- Over current shutdown
- Active clamp
- Input referenced to + V_{CC}
- E.S.D protection
- Input referenced to V_{CC}

Description

The IPS5551T is a fully protected three terminal high side switch with built-in short-circuit, over-temperature, ESD protection, inductive load capability. The input signal is referenced to V_{CC}. When the input voltage V_{CC} - V_{in} is higher than the specified threshold, the output power MOSFET is turned on. When the V_{CC} - V_{in} is lower than the specified V_{il} threshold, the output MOSFET is turned off. Input noise immunity is improved by an hysteresis. When the input is left floating, an internal current source pulls it up to V_{CC}. The over-current protection latches off the high side switch if the output current exceeds the specified I_{sd}. The over-temperature protection latches off the switch if the junction temperature exceeds the specified value T_{sd}. The device is reset by opening the input pin high.

Typical Connection

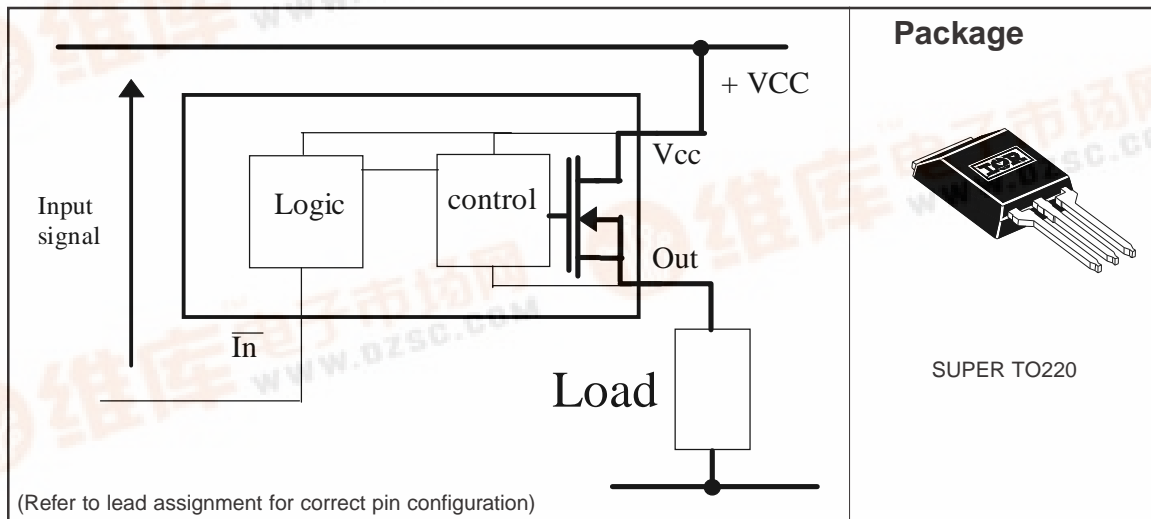

(Refer to lead assignment for correct pin configuration)

Product Summary

R _{ds(on)}	6.0mΩ (max)
V _{clamp}	40V
I _{shutdown}	100A
V _{CC} (op.)	5.5 - 18V

Truth Table

Op. Conditions	\overline{In} ⁽³⁾	Out
Normal	L	H
Normal	H	L
Over current	L	L (latched)
Over current	H	L
Over-temperature	L	L (latched)
Over-temperature	H	L

(3) \overline{In} is referenced to V_{CC}.

$\overline{In} = L$ means (V_{CC} - V_{in}) > V_{ih}

$\overline{In} = H$ means (V_{CC} - V_{in}) < V_{il}

Absolute Maximum Ratings

Absolute maximum ratings indicate sustained limits beyond which damage to the device may occur. All voltage parameters are referenced to V_{CC} lead. ($T_j = 25^\circ\text{C}$ unless otherwise specified). PCB mounting uses the standard footprint with $70\mu\text{m}$ copper thickness

Symbol	Parameter	Min.	Max.	Units	Test Conditions
$V_{CC} - V_{in\ max}$	Maximum input voltage	-0.3	30	V	
$V_{CC} - V_{in1\ max}$	Max. transient Input voltage (less than 1s)	-0.3	40		
$I_{in\ max}$	Maximum input current	-1	20	mA	
$V_{CC} - V_{out\ max}$	Maximum output voltage	-0.3	40	V	
$I_{sd\ cont.}$	Diode max. continuous current ⁽¹⁾ ($r_{th} = 62^\circ\text{C/W}$)	—	2.8	A	
$I_{sd1\ cont.}$	Diode max. continuous current ⁽¹⁾ ($r_{th} = 5^\circ\text{C/W}$)	—	35		
$I_{sd\ pulsed}$	Diode max. pulsed current ⁽¹⁾	—	100		
P_d	Power dissipation ($r_{th} = 62^\circ\text{C/W}$)	—	2	W	
ESD1	Electrostatic discharge voltage (Human Body)	—	tbd	kV	C = 100 pF, R = 1500 Ω
ESD2	Electrostatic discharge voltage (Machine Model)	—	tbd		C = 200 pF, R = 0 Ω , L=10 μH
T stor.	Max. storage temperature	-55	150	$^\circ\text{C}$	
$T_j\ max.$	Max. junction temperature	-40	150		
Tlead	Lead temperature (soldering 10 seconds)	—	300		

Thermal Characteristics

Symbol	Parameter	Typ.	Max.	Units	Test Conditions
$R_{th\ 1}$	Thermal resistance free air	60	—	$^\circ\text{C/W}$	
$R_{th\ 2}$	Thermal resistance with standard footprint	60	—		
$R_{th\ 3}$	Thermal resistance with 1" footprint	35	—		
$R_{th\ 4}$	Thermal resistance junction to case	0.7	—		

Recommended Operating Conditions

These values are given for a quick design. For operation outside these conditions, please consult the application notes.

Symbol	Parameter	Min.	Max.	Units
$V_{CC} - V_{in}$	Continuous input voltage	6	18	V
V_{CC}	Supply to power ground voltage	6	18	
I_{out}	Continuous output current ($r_{th\ c/amb.} < 5^\circ\text{C/W}$, $T_j = 125^\circ\text{C}$)	—	35	A
I_{out} $T_{amb}=85^\circ\text{C}$	Continuous output current ($T_{Ambient} = 85^\circ\text{C}$, $T_j = 125^\circ\text{C}$, free air)	—	8	

(1) Limited by junction temperature. Pulsed current is also limited by wiring

Static Electrical Characteristics

($T_j = 25^\circ\text{C}$ and $V_{cc} = 14\text{V}$ unless otherwise specified.)

Symbol	Parameter	Min.	Typ.	Max.	Units	Test Conditions
$R_{ds(on)1}$	ON state resistance	—	4.6	6.0	m Ω	$I_{out}=35\text{A}, V_{cc} - V_{in}=12\text{V}$ see Fig. 6
$R_{ds(on)2}$	ON state resistance	—	4.6	—		$I_{out}=17\text{A}, V_{cc} - V_{in}= 6\text{V}$
$R_{ds(on)3}$	ON state resistance $T_j = 150^\circ\text{C}$	—	7.4	—		$I_{out} = 35\text{A}, T_j = 150^\circ\text{C}$
V_{clamp1}	V_{cc} to V_{out} active clamp voltage	35	40	—	V	$I_{out} = 10\text{mA}$
V_{clamp2}	V_{cc} to V_{out} active clamp voltage	—	42	48		$I_{out} = 35\text{A} - t < 100\mu\text{s}$
V_{sd}	Body diode forward voltage	—	0.85	1		$I_d = 35\text{A}, V_{cc} - V_{in} = 0\text{V}$
$V_{cc} (op)$	Operating voltage range	5.5	—	28		
I_q	Quiescent current	—	13	50	μA	$V_{cc}-V_{in}=0\text{V}, V_{cc}-V_{out}= 12\text{V}$
I_{in}	Input current	3	6.5	12	mA	$V_{cc} - V_{in} = 14\text{V}$
$I_{in, on}$	Input current when ON	—	1.3	—		$V_{cc} - V_{in} = V_{ih}$
V_{ih}	High level input threshold voltage	—	4.75	5.5	V	$V_{cc} - V_{in}$ (note 2)
V_{il}	Low level input threshold voltage	3	4.05	—		$V_{cc} - V_{in}$ (note 2)
V_{hys}	Input hysteresis	0.3	0.6	1.5		

Switching Electrical Characteristics

$V_{cc} = 14\text{V}$, Resistive Load = 0.4Ω , $T_j = 25^\circ\text{C}$, (unless otherwise specified).

Symbol	Parameter	Min.	Typ.	Max.	Units	Test Conditions
T_{don}	Turn-on delay time to $V_{cc} - V_{out} = 0.9 V_{cc}$	—	10	30	μs	See figure 2
T_r1	Rise time to $V_{cc} - V_{out} = 5\text{V}$	—	16	50		
T_r2	Rise time from the end of T_r1 to $V_{cc} - V_{out} = 0.1 V_{cc}$	—	200	400		
$dV/dt (on)$	Turn on dV/dt	—	1.2	5	V/ μs	
E_{on}	Turn ON energy	—	25	—	mJ	See figure 3
T_{doff}	Turn-off delay time $V_{cc} - V_{out} = 0.1 V_{cc}$	—	130	300	μs	
T_f	Fall time to $V_{cc} - V_{out} = 0.9 V_{cc}$	—	25	50		
$dV/dt (off)$	Turn OFF dV/dt	—	2	6	V/ μs	
E_{off}	Turn OFF energy	—	6	—	mJ	

Protection Characteristics

$T_j = 25^\circ\text{C}$, and $V_{cc} = 14\text{V}$ (unless otherwise specified).

Symbol	Parameter	Min.	Typ.	Max.	Units	Test Conditions
T_{sd}	Over temperature shutdown threshold	—	165	—	$^\circ\text{C}$	See fig. 4
I_{sd}	Over current shutdown threshold	60	100	150	A	
T_{reset}	Minimum time for protection reset	—	50	—	μs	

(2) Input threshold are measured directly between the input pin and the tab. Any parasitic resistance in common between the load current path and the input signal path can significantly affect the thresholds.

IPS5551T

International
IR Rectifier

Functional Block Diagram

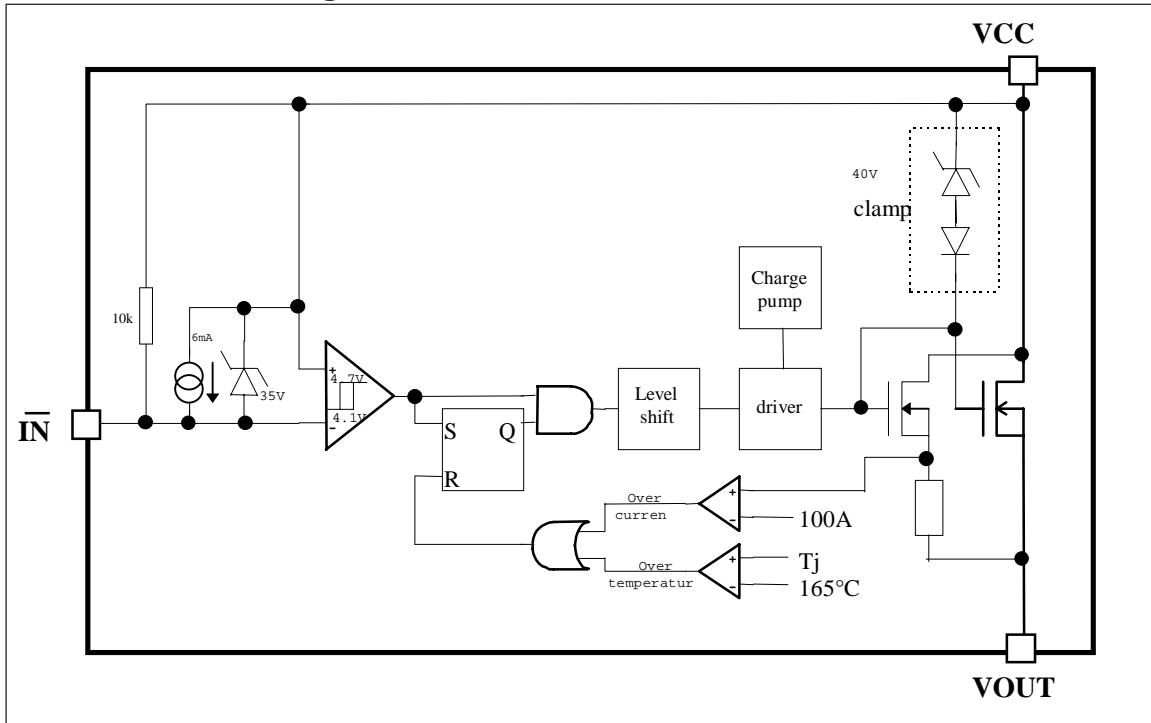

Lead Assignments

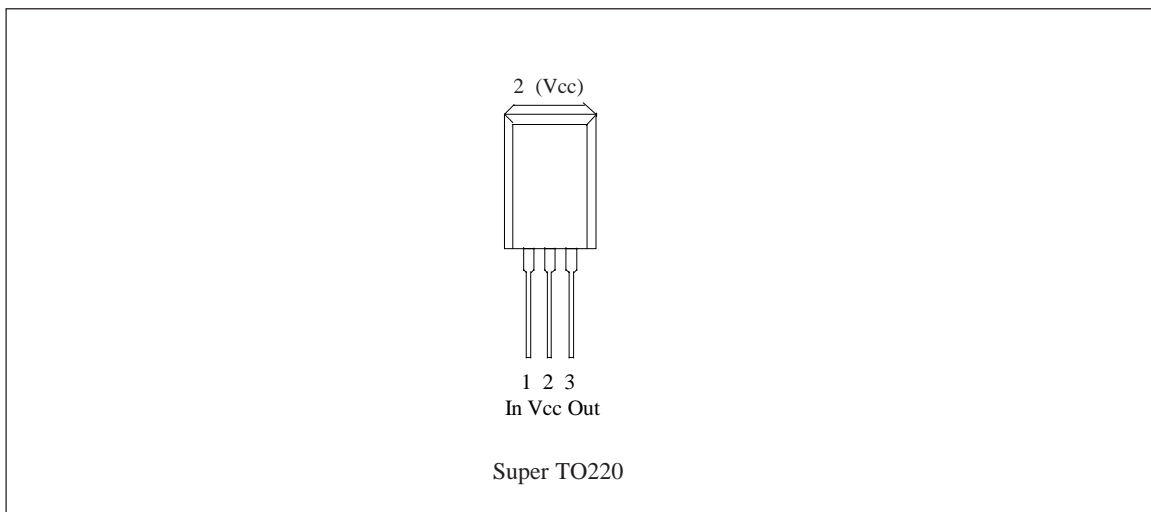

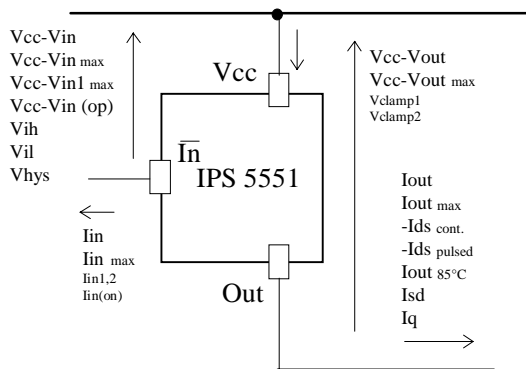

Figure 1 - Voltages and currents definition

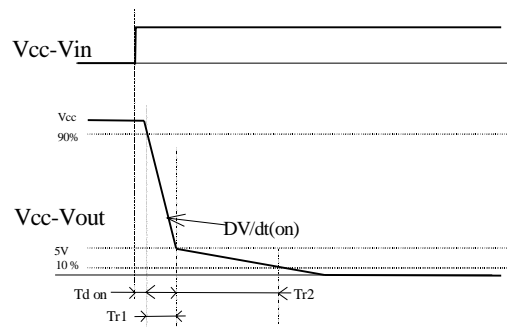

Figure 2 - Switching time definitions (turn-on)

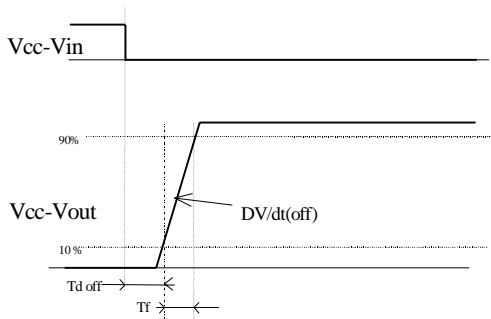

Figure 3 - Switching time definitions (turn-off)

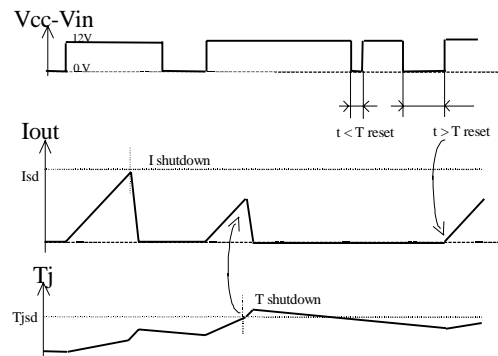

Figure 4 - Protection timing diagram

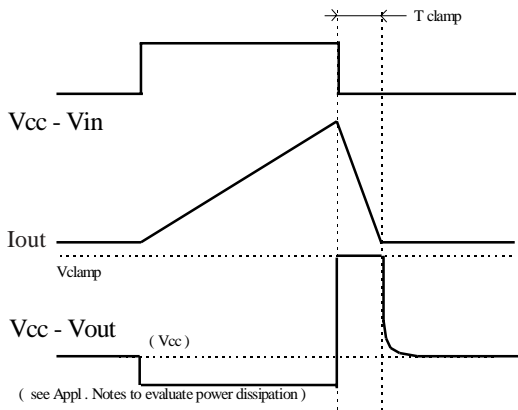

Figure 5 - Active clamp waveforms

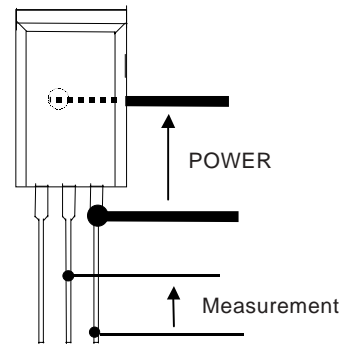

Figure 6 - Rds(on) measurement schematic

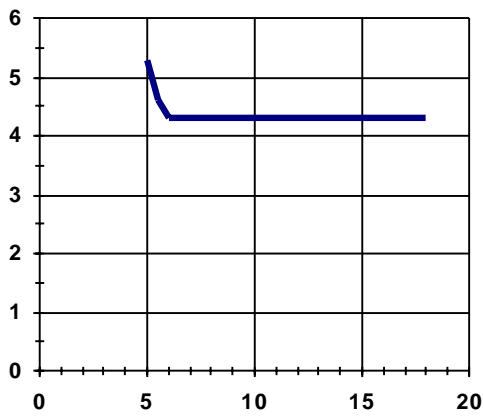

Figure 7 - Rds(on) (mΩ) Vs V_{CC}-V_{IN} (V)

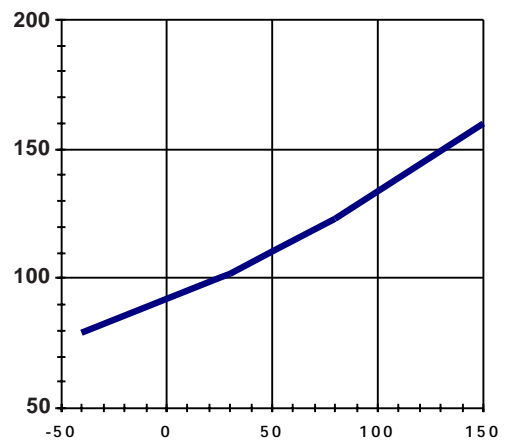

Figure 8 - Normalized Rds(on) (%) Vs T_j (°C)

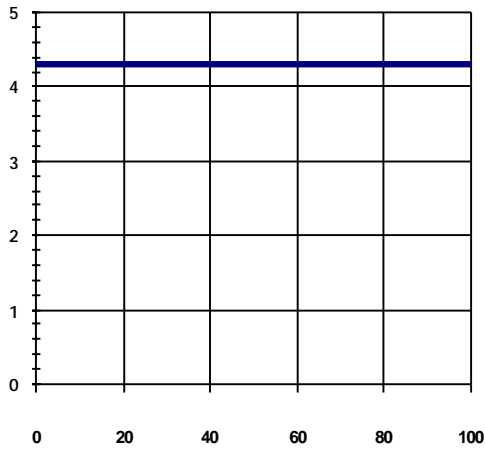

Figure 9 - $R_{ds(on)}$ (m Ω) Vs I_{out} (A)

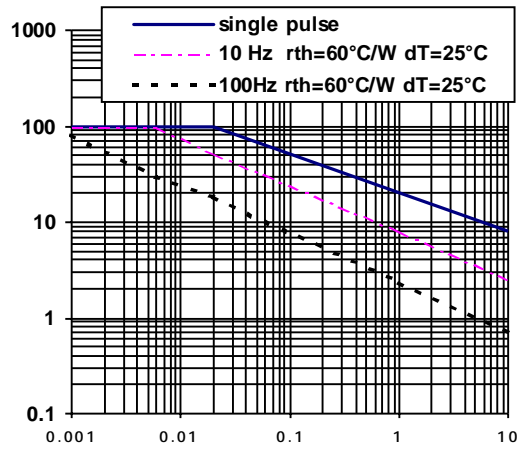

Figure 10 - I_{clamp} (A) Vs Inductive Load (μ H)

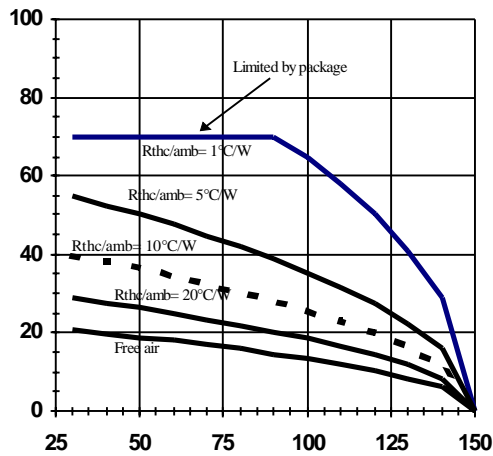

Figure 11 - Max. load current (A) Vs Temperature ($^{\circ}$ C)

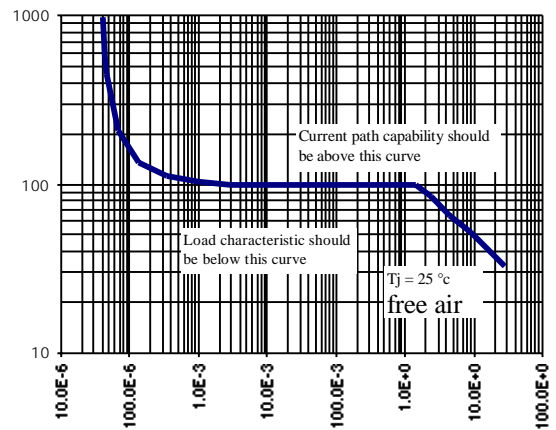

Figure 12 - I_{out} (A) Vs Protection resp. Time (ms)

IPS5551T

International
IR Rectifier

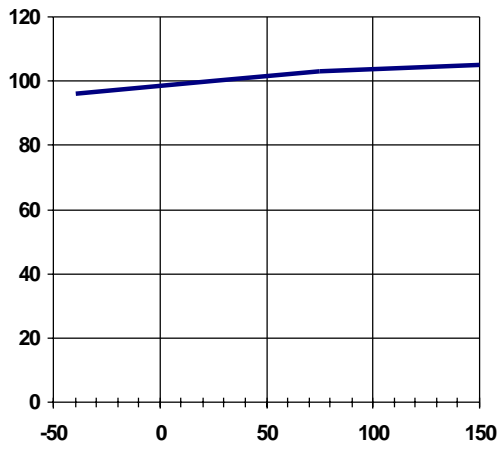

Figure 13 - I_{sd} (A) Vs T_j (°C)

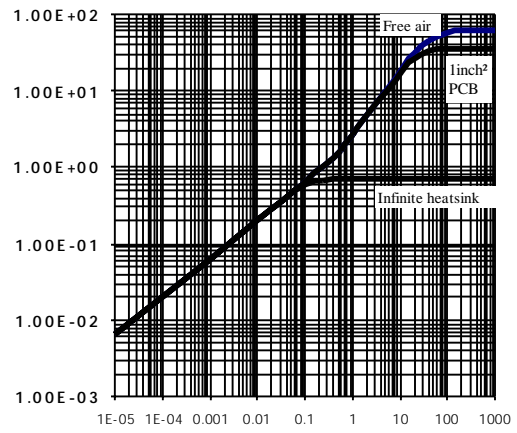

Figure 14 - Transient thermal impedance (°C/W) Vs Time (s)

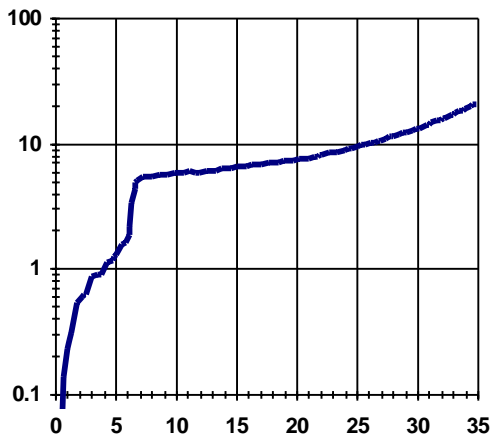

Figure 15 - I_{cc} (mA) Vs V_{cc}-V_{in} (V)

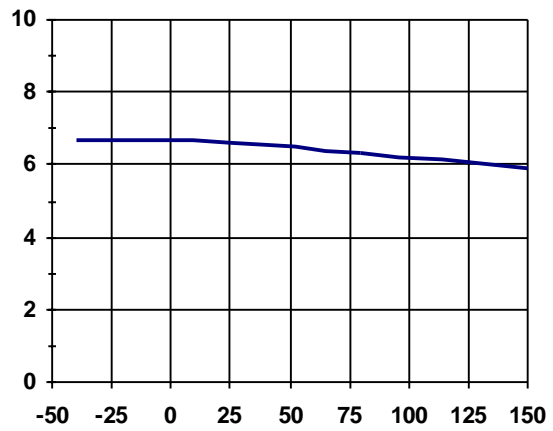

Figure 16 - I_{in} (mA) Vs T_j (°C)

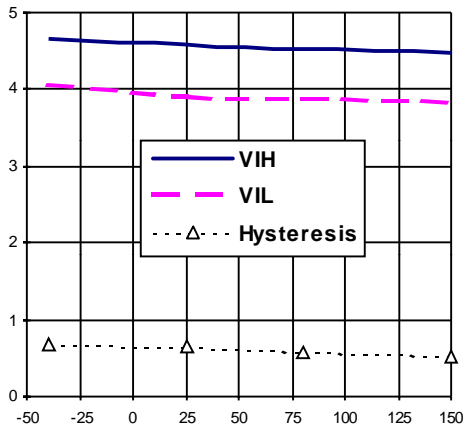

Figure 17 - V_{IH} , V_{IL} threshold (V) Vs T_j (°C)

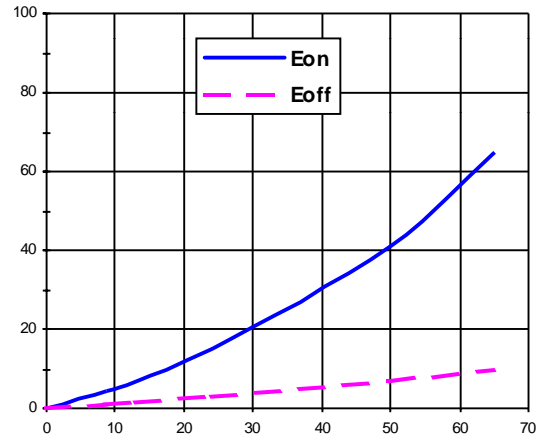

Figure 18 - E_{on} , E_{off} (mJ) Vs I_{out} (A)

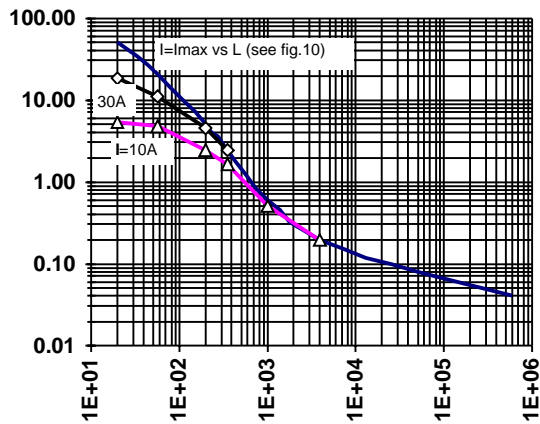
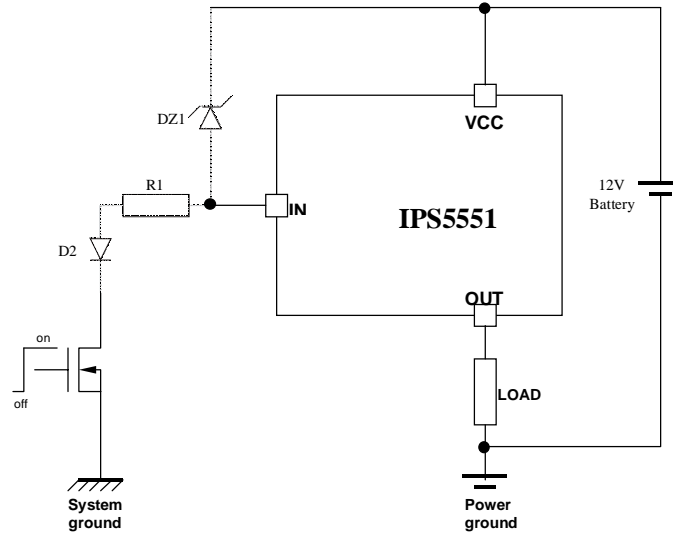

Figure 19 - E_{on} (mJ) Vs Inductive load (μH)
($V_{cc} = 14\text{V}$, $R_{load} = 0.5\Omega$)

IPS5551T

International
IR Rectifier



DZ1, R1 : optional additional voltage transient protection
D2 : optional additional reverse battery protection
See application note for details

Figure 20 - Automotive typical connection

Case outline Super TO220

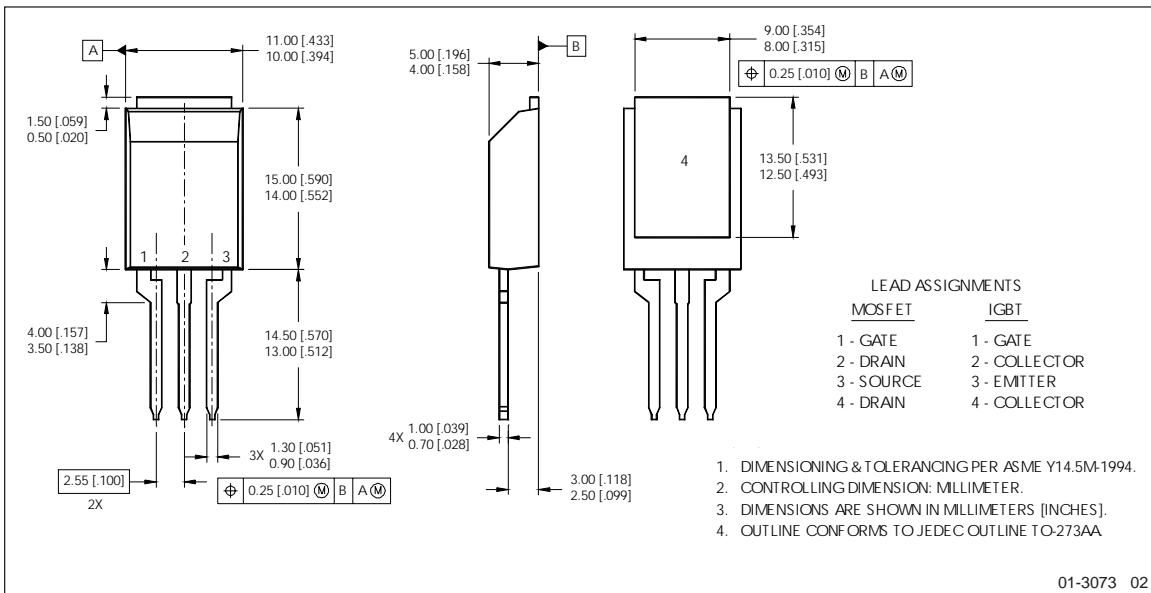

01-3073 02

IR WORLD HEADQUARTERS: 233 Kansas St., El Segundo, California 90245 Tel: (310) 252-7105
Data and specifications subject to change without notice. 6/21/2002