

# ADS7869

## **Analog Motor Control Front-End with Simultaneous Sampling on Seven S/H Capacitors and Three 1MSPS, 12-Bit, 12-Channel ADCs**

### **Data Manual**

Literature Number: SBAS253B  
May 2003 – Revised November 2004

PRODUCTION DATA information is current as of publication date. Products conform to specifications per the terms of Texas Instruments standard warranty. Production processing does not necessarily include testing of all parameters.

## IMPORTANT NOTICE

Texas Instruments Incorporated and its subsidiaries (TI) reserve the right to make corrections, modifications, enhancements, improvements, and other changes to its products and services at any time and to discontinue any product or service without notice. Customers should obtain the latest relevant information before placing orders and should verify that such information is current and complete. All products are sold subject to TI's terms and conditions of sale supplied at the time of order acknowledgment.

TI warrants performance of its hardware products to the specifications applicable at the time of sale in accordance with TI's standard warranty. Testing and other quality control techniques are used to the extent TI deems necessary to support this warranty. Except where mandated by government requirements, testing of all parameters of each product is not necessarily performed.

TI assumes no liability for applications assistance or customer product design. Customers are responsible for their products and applications using TI components. To minimize the risks associated with customer products and applications, customers should provide adequate design and operating safeguards.

TI does not warrant or represent that any license, either express or implied, is granted under any TI patent right, copyright, mask work right, or other TI intellectual property right relating to any combination, machine, or process in which TI products or services are used. Information published by TI regarding third-party products or services does not constitute a license from TI to use such products or services or a warranty or endorsement thereof. Use of such information may require a license from a third party under the patents or other intellectual property of the third party, or a license from TI under the patents or other intellectual property of TI.

Reproduction of information in TI data books or data sheets is permissible only if reproduction is without alteration and is accompanied by all associated warranties, conditions, limitations, and notices. Reproduction of this information with alteration is an unfair and deceptive business practice. TI is not responsible or liable for such altered documentation.

Resale of TI products or services with statements different from or beyond the parameters stated by TI for that product or service voids all express and any implied warranties for the associated TI product or service and is an unfair and deceptive business practice. TI is not responsible or liable for any such statements.

Following are URLs where you can obtain information on other Texas Instruments products and application solutions:

<b>Products</b>		<b>Applications</b>	
Amplifiers	<a href="http://amplifier.ti.com">amplifier.ti.com</a>	Audio	<a href="http://www.ti.com/audio">www.ti.com/audio</a>
Data Converters	<a href="http://dataconverter.ti.com">dataconverter.ti.com</a>	Automotive	<a href="http://www.ti.com/automotive">www.ti.com/automotive</a>
DSP	<a href="http://dsp.ti.com">dsp.ti.com</a>	Broadband	<a href="http://www.ti.com/broadband">www.ti.com/broadband</a>
Interface	<a href="http://interface.ti.com">interface.ti.com</a>	Digital Control	<a href="http://www.ti.com/digitalcontrol">www.ti.com/digitalcontrol</a>
Logic	<a href="http://logic.ti.com">logic.ti.com</a>	Military	<a href="http://www.ti.com/military">www.ti.com/military</a>
Power Mgmt	<a href="http://power.ti.com">power.ti.com</a>	Optical Networking	<a href="http://www.ti.com/opticalnetwork">www.ti.com/opticalnetwork</a>
Microcontrollers	<a href="http://microcontroller.ti.com">microcontroller.ti.com</a>	Security	<a href="http://www.ti.com/security">www.ti.com/security</a>
		Telephony	<a href="http://www.ti.com/telephony">www.ti.com/telephony</a>
		Video & Imaging	<a href="http://www.ti.com/video">www.ti.com/video</a>
		Wireless	<a href="http://www.ti.com/wireless">www.ti.com/wireless</a>

Mailing Address: Texas Instruments  
Post Office Box 655303 Dallas, Texas 75265

## Contents

<b>Features</b> .....	<b>1</b>
<b>Applications</b> .....	<b>1</b>
<b>Description</b> .....	<b>1</b>
1.1 Ordering Information .....	2
1.2 Absolute Maximum Ratings .....	2
1.3 Recommended Operating Conditions .....	2
1.4 Package Dissipation Ratings .....	2
1.5 Electrical Characteristics .....	3
1.6 Pinout Drawing .....	6
1.7 Pin Functions .....	7
1.8 Basic Circuit Configuration .....	9
1.9 Typical Application Circuit .....	10
1.10 Typical Characteristics .....	11
1.11 Functional Block Diagram .....	15
<b>2 Analog Section</b> .....	<b>16</b>
2.1 Fully Differential Analog Inputs .....	16
2.1.1 Analog-to-Digital Converter Inputs .....	16
2.1.2 Window Comparator Inputs .....	17
2.1.3 Sign Comparator Inputs .....	17
2.2 Analog-To-Digital Converter .....	17
2.2.1 $\overline{\text{HOLD1}}$ , $\overline{\text{HOLD2}}$ .....	17
2.2.2 Clock .....	18
2.2.3 Reset .....	18
2.2.4 Gain Adjustment .....	18
2.2.5 Offset Adjustment .....	18
2.2.6 Transition Noise .....	19
2.3 Sign Comparators .....	19
2.4 Window Comparators .....	21
2.5 8-Bit Digital-to-Analog Converter .....	22
2.6 Internal Reference .....	22
2.7 Grounding .....	22
2.8 Supply .....	22

# Analog Motor Control Front-End with Simultaneous Sampling on Seven S/H Capacitors and Three 1MSPS, 12-Bit, 12-Channel ADCs ADS7869



SBAS253B – MAY 2003 – REVISED NOVEMBER 2004

<b>3</b>	<b>Digital Section</b>	<b>23</b>
3.1	Introduction	23
3.2	VECANA Interface	24
3.2.1	Input Channel Selection	25
3.2.2	VECANA Timing Characteristics	26
3.2.3	WINCLK Selection	27
3.3	Serial Peripheral Interface (SPI)	27
3.3.1	SPI Timing Characteristics	29
3.4	Parallel Interface	30
3.4.1	Parallel Read and Write Control	30
3.4.2	Mode 10 Bus Access	31
3.4.3	Mode 11 Bus Access (Standard Mode)	33
3.4.4	Mode 11 Bus Access (TMS320c54xx DSP Family-Compatible Mode)	35
3.5	Register Map	37
3.6	Register Descriptions	39
3.6.1	FIFO Data Register (00H)	39
3.6.2	Offset Registers (01H – 0CH)	40
3.6.3	Gain Registers (0DH to 18H)	40
3.6.4	WINDAC Register (19H)	40
3.6.5	Control Register (1AH)	41
3.6.6	Counter Control/Status Register (1BH)	42
3.6.7	Edge Count Register (1CH, 1DH, 20H and 21H)	43
3.6.8	Edge Period Register (1EH and 22H)	43
3.6.9	Edge Time Period Register (1FH and 23H)	44
3.6.10	FIFO Test Register (24H)	44
3.6.11	Comparator Test Register (25H)	45
3.6.12	Interrupt Register (26H)	46
3.6.13	Parallel Register (27H)	47
3.6.14	Reset Register (28H)	48
3.7	FIFO	49
3.7.1	DAV Timing Characteristics	51
3.8	Digital Counter Modules	52
3.8.1	Operation	52
3.8.2	Digital Noise Filter	53
3.8.3	Binary Counters and Registers	56
3.9	Interrupt	58
3.10	Reset	58
3.10.1	Reset Timing Characteristics	58

## List of Illustrations

1–1. Typical Motor Control Application .....	10
1–2. Functional Diagram .....	15
1–3. Equivalent Input Circuit to the ADCs .....	16
1–4. Equivalent Input Circuit of the Window Comparators .....	17
1–5. Histogram of 8000 Conversions .....	19
1–6. Typical Transfer Function of a Sign Comparator .....	19
1–7. Position Sensor Comparator Overdrive .....	20
1–8. Current Sign Comparator Overdrive .....	20
1–9. Typical Transfer Function of a Window Comparator .....	21
1–10. VECANA Access .....	26
1–11. One SPI Transfer Cycle .....	27
1–12. Continuous SPI Transfer Cycle .....	28
1–13. SPI Access .....	29
1–14. Mode 10 Read Access .....	31
1–15. Mode 10 Write Access .....	32
1–16. Mode 11 Read Access (Standard Mode) .....	33
1–17. Mode 11 Write Access (Standard Mode) .....	34
1–18. Mode 11 Read Access (TMS320c54xx mode) .....	35
1–19. Mode 11 Write Access (TMS320c54xx mode) .....	36
1–20. FIFO Structure .....	49
1–21. FIFO Block Diagram .....	50
1–22. Timing of the DAV Signal .....	51
1–23. Block Diagram of a Counter Module .....	52
1–24. Digital Noise Filter Block Diagram .....	53
1–25. Timing Diagram of the Counter Signals with the Digital Noise Filter Enabled .....	54
1–26. Timing Diagram of the Counter Signals with the Digital Noise Filter Disabled .....	55
1–27. Detail Counter Block Diagram .....	56
1–28. Detail Counter Timing Diagram .....	57
1–29. Timing Diagram of the Reset Signal RST .....	58

## List of Tables

1–1. Selection of Interface Mode .....	23
1–2. Mode vs Pin Functions .....	23
1–3. DAC Input/Output Relationships .....	24
1–4. VECANA Gain Select Information .....	24
1–5. 13-bit VECANA ADIN Word Format .....	25
1–6. Controls for Input Multiplexers and Sample Holds .....	25
1–7. Window Comparator Clock .....	27
1–8. SPI Write 24-bit Word Format .....	27
1–9. Host Parallel Port Operation .....	30
1–10. Register Map Write 16-bit Data .....	37
1–11. Register Map Read 16-bit Data .....	38
1–12. FIFO Output Word Format .....	39
1–13. Offset Registers .....	40
1–14. Gain Registers .....	40
1–15. WINDAC Register .....	40
1–16. Control Registers .....	41
1–17. Counter/Control Status Register .....	42
1–18. Synchronous Latched Edge Count Register .....	43
1–19. Asynchronous Latched Edge Count Register .....	43
1–20. Edge Period Register .....	43
1–21. Edge Time Period Register .....	44
1–22. FIFO Test Register .....	44
1–23. Comparator Test Register .....	45
1–24. Interrupt Register .....	46
1–25. Parallel Register .....	47
1–26. Reset Register .....	48
1–27. FIFO 16-bit Data Read Format .....	49

## FEATURES

- Seven Simultaneously-Sampling Sample-and-Hold (S/H) Capacitors
- Fully Differential Inputs
- Flexible Digital Interface with Four Modes
  - One Mode 100% Software-Compatible to VECANA01
  - SPI and Two Parallel Modes
- Two Up—Down Counter Modules On-Chip
- 12-Bit System Gain Adjustment for Every Channel
- 12-Bit Accurate System Offset Adjustment for Every Channel



## APPLICATIONS

- Motor Control

## DESCRIPTION

The ADS7869 is a motor control front-end that includes three analog-to-digital converters (ADCs) with a total of seven sample-and-hold capacitors and 12 fully differential input channels. There are four sign comparators connected to four input channels. There are also three additional fully differential inputs; each input is connected to a window comparator and a sign comparator.

In addition, the ADS7869 also offers a very flexible digital interface with a parallel port that can be configured to different standards. Furthermore, a serial peripheral interface (SPI) and a specialized serial interface with three data lines (VECANA01 mode) are provided. This allows the ADS7869 to interface with most digital signal processors (DSPs) or microcontrollers. The chip is specialized for motor-control applications. For the position sensor analysis, two up—down counters are added on the silicon. This feature ensures that the analog input of the encoder is held at the same point of time as the counter value.

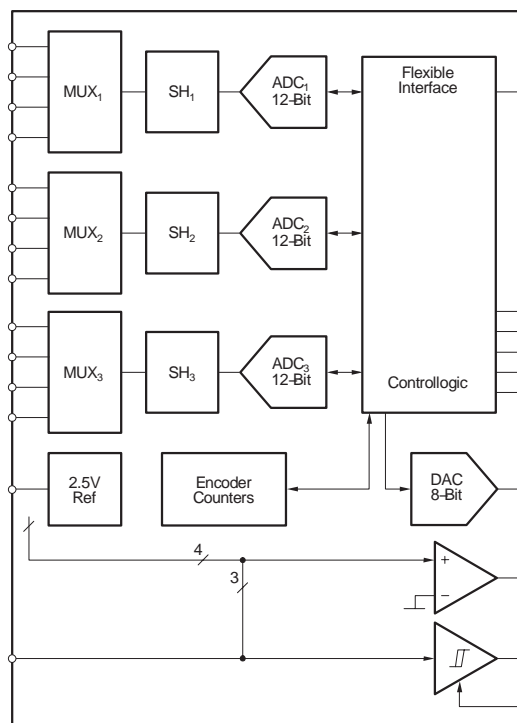

# Analog Motor Control Front-End with Simultaneous Sampling on Seven S/H Capacitors and Three 1MSPS, 12-Bit, 12-Channel ADCs ADS7869



SBAS253B – MAY 2003 – REVISED NOVEMBER 2004

## 1.1 ORDERING INFORMATION(1)

PRODUCT	MAXIMUM INTEGRAL LINEARITY ERROR (LSB)	NO MISSING CODES ERROR (LSB)	PACKAGE-LEAD	PACKAGE DESIGNATOR	SPECIFIED TEMPERATURE RANGE	ORDERING NUMBER	TRANSPORT MEDIA, QUANTITY
ADS7869I	±2	11	TQFP-100	PZT	–40°C to +85°C	ADS7869IPZTT	Tape and Reel, 250
						ADS7869IPZTR	Tape and Reel, 1000

(1) For the most current package and ordering information, see the Package Option Addendum located at the end of this data manual.

## 1.2 ABSOLUTE MAXIMUM RATINGS

over operating free-air temperature range unless otherwise noted(1)

	ADS7869I	UNIT
Supply voltage, AV <sub>DD</sub> to AGND	–0.3 to 6	V
Supply voltage, BV <sub>DD</sub> to BGND	–0.3 to 6	V
Analog input voltage with respect to AGND	AGND – 0.3 to AV <sub>DD</sub> + 0.3	V
Reference input voltage with respect to AGND	AGND – 0.3 to AV <sub>DD</sub> + 0.3	V
Digital input voltage with respect to BGND	BGND – 0.3 to BV <sub>DD</sub> + 0.3	V
Ground voltage difference AGND to BGND	± 0.3	V
Input current to any pin except supply	–10 to +10	mA
Operating virtual junction temperature range, T <sub>J</sub>	–40 to +150	°C
Operating free-air temperature range, T <sub>A</sub>	–40 to +85	°C
Storage temperature range, T <sub>STG</sub>	–65 to +150	°C
Lead temperature 1,6mm (1/16-inch) from case for 10 seconds	+260	°C

(1) Stresses beyond those listed under *Absolute Maximum Ratings* may cause permanent damage to the device. These are stress ratings only, and functional operation of the device at these or any other conditions beyond those indicated under *Recommended Operating Conditions* is not implied. Exposure to absolute-maximum-rated conditions for extended periods may affect device reliability.

## 1.3 RECOMMENDED OPERATING CONDITIONS

	MIN	NOM	MAX	UNIT
Supply Voltage, AGND to AV <sub>DD</sub>	4.5	5	5.5	V
Supply Voltage, BGND to BV <sub>DD</sub>	Low-Voltage Levels		3.6	V
	5V Logic Levels		5.5	V
Reference Input Voltage	2.475	2.5	2.525	V
Analog Inputs (also see <i>Fully Differential Analog Inputs</i> section)	+IN – (–IN)		+REF_ADC	V
Operating junction temperature range, T <sub>J</sub>	–40		+85	°C

## 1.4 PACKAGE DISSIPATION RATINGS

BOARD	PACKAGE	R <sub>θJC</sub>	R <sub>θJA</sub>	DERATING FACTOR ABOVE T <sub>A</sub> = 25°C	T <sub>A</sub> ≤ 25°C POWER RATING	T <sub>A</sub> = 70°C POWER RATING	T <sub>A</sub> = 85°C POWER RATING
Low-K(1)	PZT	3.5°C/W	45°C/W	22.222mW/°C	2778mW	1778mW	1444mW
High-K(2)	PZT	3.5°C/W	2.82°C/W	35.461mW/°C	4433mW	2837mW	2305mW

(1) The JEDEC Low-K (1s) board design used to derive this data was a 3-inch x 3-inch, two-layer board with 2-ounce copper traces on top of the board.

(2) The JEDEC High-K (2s2p) board design used to derive this data was a 3-inch x 3-inch, multilayer board with 1-ounce internal power and ground planes and 2-ounce copper traces on the top and bottom of the board.



### 1.5 ELECTRICAL CHARACTERISTICS

Over recommended operating free-air temperature range at  $-40^{\circ}\text{C}$  to  $+85^{\circ}\text{C}$ ,  $V_{\text{DD}} = 5\text{V}$ ,  $BV_{\text{DD}} = 3.3\text{V}$ ,  $V_{\text{REF}} = \text{internal } +2.5\text{V}$ ,  $f_{\text{CLK}} = 16\text{MHz}$ ,  $f_{\text{SAMPLE}} = 1\text{MSPS}$ , unless otherwise noted.

PARAMETER	CONDITION	ADS7869I			UNIT
		MIN	TYP(1)	MAX	
<b>Resolution</b>		12			Bit
<b>Analog Input</b>					
Full-scale Voltage, Differential	See Gain Adjustment	-REF_ADC		+REF_ADC	V
Input Capacitance			10		pF
Input Leakage Current			$\pm 1$		nA
CMRR	At DC		64		dB
<b>DC Accuracy</b>					
No Missing Codes		11			Bit
INL Integral Linearity Error			$\pm 1$	$\pm 2.5$	LSB
DNL Differential Linearity Error			$\pm 0.65$	$\pm 2$	LSB
$V_{\text{OS}}$ Bipolar Offset Error	Synchronous Channels		2	$\pm 6$	LSB
$V_{\text{OS}}$ Bipolar Offset Error	AX and BX Channels		5	$\pm 8$	LSB
$V_{\text{OS}}$ Bipolar Offset Match	IU, IV, and IW Channels		2.5	6	LSB
$V_{\text{OS}}$ Bipolar Offset Match	A1, B1, A2, and B2 Channels		0.5	3	LSB
$V_{\text{OS}}$ Bipolar Offset Match	AX and BX Channels		0.5	3	LSB
$TCV_{\text{OS}}$ Bipolar Offset Error Drift			1		$\mu\text{V}/^{\circ}\text{C}$
Gain Error	Max Input Range, Related to REF <sub>IN</sub>		0.05	1	%
Gain Error	Every Other Input Range		1.5	4	%
Gain Error Drift	Max Input Range, Related to REF <sub>IN</sub>		3		ppm/ $^{\circ}\text{C}$
PSRR Power-Supply Rejection Ratio	$4.5\text{V} < V_{\text{DD}} < 5.5\text{V}$		70		dB
<b>Sampling Dynamics</b>					
$t_{\text{CONV}}$ Conversion Time per ADC	$16\text{MHz} \leq f_{\text{CLK}} \leq 1\text{MHz}$	0.75		12	$\mu\text{s}$
$t_{\text{AQ}}$ Acquisition Time		250			ns
Throughput Rate				1000	kSPS
Aperture Delay				20	ns
Aperture Delay Matching			1		ns
Aperture Jitter			50		ps
Clock Frequency		1		16	MHz
<b>AC Accuracy</b>					
Total Harmonic Distortion	THD	$V_{\text{IN}} = \pm 2.5V_{\text{PP}}$ at 10kHz		-78	dB
Signal-to-Noise Distortion	SNR	$V_{\text{IN}} = \pm 2.5V_{\text{PP}}$ at 10kHz		71	dB
Signal-to-Noise + Distortion	SINAD	$V_{\text{IN}} = \pm 2.5V_{\text{PP}}$ at 10kHz		70	dB
<b>Digital Inputs(2)</b>					
Logic Family			CMOS		
$V_{\text{IH}}$ High-Level Input Voltage		$0.7 \cdot V_{\text{DD}}$		$BV_{\text{DD}} + 0.3$	V
$V_{\text{IL}}$ Low-Level Input Voltage		-0.3		$0.3 \cdot V_{\text{DD}}$	V
$I_{\text{IN}}$ Input Current	$BV_{\text{DD}}$ to BGND			$\pm 50$	nA
$C_{\text{I}}$ Input Capacitance			5		pF
<b>Digital Outputs(2)</b>					
Logic Family			CMOS		
$V_{\text{OH}}$ High-Level Output Voltage	$BV_{\text{DD}} = 4.5\text{V}$ , $I_{\text{OH}} = -100\mu\text{A}$	4.44			V
$V_{\text{OL}}$ Low-Level Output Voltage	$BV_{\text{DD}} = 4.5\text{V}$ , $I_{\text{OL}} = +100\mu\text{A}$			0.5	V
$I_{\text{OZ}}$ High-Impedance-State Output Current	$V_{\text{I}} = BV_{\text{DD}}$ to BGND			$\pm 50$	nA
$C_{\text{O}}$ Output Capacitance			5		pF
$C_{\text{L}}$ Load Capacitance				30	pF

(1) All values are at  $T_{\text{A}} = +25^{\circ}\text{C}$ .

(2) Applies for 5.0V nominal supply:  $4.5\text{V} < BV_{\text{DD}} < 5.5\text{V}$ .

(3) Applies for 3.0V nominal supply:  $2.7\text{V} < BV_{\text{DD}} < 3.6\text{V}$ .

# Analog Motor Control Front-End with Simultaneous Sampling on Seven S/H Capacitors and Three 1MSPS, 12-Bit, 12-Channel ADCs ADS7869



SBAS253B – MAY 2003 – REVISED NOVEMBER 2004

## 1.5 ELECTRICAL CHARACTERISTICS (continued)

Over recommended operating free-air temperature range at  $-40^{\circ}\text{C}$  to  $+85^{\circ}\text{C}$ ,  $\text{AV}_{\text{DD}} = 5\text{V}$ ,  $\text{BV}_{\text{DD}} = 3.3\text{V}$ ,  $\text{V}_{\text{REF}} = \text{internal } +2.5\text{V}$ ,  $\text{f}_{\text{CLK}} = 16\text{MHz}$ ,  $\text{f}_{\text{SAMPLE}} = 1\text{MSPS}$ , unless otherwise noted.

PARAMETER	CONDITION	ADS7869I			UNIT
		MIN	TYP(1)	MAX	
<b>Digital Inputs<sup>(3)</sup></b>					
Logic Family			LVC MOS		
$\text{V}_{\text{IH}}$ High-Level Input Voltage	$\text{BV}_{\text{DD}} = 3.6\text{V}$	2		$\text{BV}_{\text{DD}} + 0.3$	V
$\text{V}_{\text{IL}}$ Low-Level Input Voltage	$\text{BV}_{\text{DD}} = 2.7\text{V}$	-0.3		0.8	V
$\text{I}_{\text{IN}}$ Input Current	$\text{V}_\text{I} = \text{BV}_{\text{DD}}$ to BGND			$\pm 50$	nA
$\text{C}_\text{I}$ Input Capacitance			5		pF
<b>Digital Outputs<sup>(3)</sup></b>					
Logic Family			LVC MOS		
$\text{V}_{\text{OH}}$ High-Level Output Voltage	$\text{BV}_{\text{DD}} = 2.7\text{V}$ , $\text{I}_{\text{OH}} = -100\mu\text{A}$	$\text{BV}_{\text{DD}} - 0.2$			V
$\text{V}_{\text{OL}}$ Low-Level Output Voltage	$\text{BV}_{\text{DD}} = 2.7\text{V}$ , $\text{I}_{\text{OL}} = +100\mu\text{A}$			0.2	V
$\text{I}_{\text{OZ}}$ High-Impedance-State Output Current	$\text{V}_\text{I} = \text{BV}_{\text{DD}}$ to BGND			$\pm 50$	nA
$\text{C}_\text{O}$ Output Capacitance			5		pF
$\text{C}_\text{L}$ Load Capacitance				30	pF
<b>Power Supply</b>					
$\text{AV}_{\text{DD}}$ Analog Supply Voltage		4.5		5.5	V
$\text{BV}_{\text{DD}}$ Buffer I/O Supply Voltage		2.7		5.5	V
$\text{AI}_{\text{DD}}$ Analog Supply Current			45	50	mA
$\text{BI}_{\text{DD}}$ Buffer I/O Supply Current			2		mA
Power Dissipation				250	mW
<b>Reference Output</b>					
$\text{V}_{\text{REF}}$ Reference Output Voltage	$-40^{\circ}\text{C} > \text{t} > +85^{\circ}\text{C}$	2.475	2.500	2.525	V
$\text{V}_{\text{REF}}$ Reference Output Voltage	at $25^{\circ}\text{C}$	2.480	2.500	2.520	V
$\text{dV}_{\text{REF}}/\text{dT}$ Reference Voltage Drift			$\pm 20$		ppm/ $^{\circ}\text{C}$
PSRR Power-Supply Rejection Ratio			60		dB
$\text{I}_{\text{OUT}}$ Output Current	DC Current			1	$\mu\text{A}$
$\text{I}_{\text{SC}}$ Short-Circuit Current			1		mA
$\text{t}_{\text{ON}}$ Turn-On Setting Time			100		$\mu\text{s}$
<b>Reference Input</b>					
$\text{V}_{\text{IN}}$ Reference Input Voltage		2.475	2.5	2.525	V
Input Resistance			100		$\text{M}\Omega$
Input Capacitance			5		pF
<b>Digital-to-Analog Converter</b>					
Resolution		8			Bits
Output Range	$\text{I}_{\text{OUT}} = 0$	0		2.49	V
INL Integral Linearity Error				$\pm 1$	LSB
DNL Differential Linearity Error				$\pm 2$	LSB
Offset Error			0.5	1	LSB
Full-Scale Error	FS = Internal Reference Voltage – 1LSB			$\pm 1$	%
$\text{I}_{\text{OUT}}$ Output Current				0.5	$\mu\text{A}$
Output Settling Time	to 0.5LSB, no load capacitance		0.2	1	$\mu\text{s}$
<b>Position Sensor Sign Comparator</b>					
Input Range	Lower Voltage of Differential Inputs	0		$\text{AV}_{\text{DD}} - 1.8$	V
Offset Range			$\pm 5$	$\pm 30$	mV
Hysteresis			75	100	mV
Delay Time			25	150	ns

(1) All values are at  $\text{T}_\text{A} = +25^{\circ}\text{C}$ .

(2) Applies for 5.0V nominal supply:  $4.5\text{V} < \text{BV}_{\text{DD}} < 5.5\text{V}$ .

(3) Applies for 3.0V nominal supply:  $2.7\text{V} < \text{BV}_{\text{DD}} < 3.6\text{V}$ .

## 1.5 ELECTRICAL CHARACTERISTICS (continued)

Over recommended operating free-air temperature range at  $-40^{\circ}\text{C}$  to  $+85^{\circ}\text{C}$ ,  $V_{\text{DD}} = 5\text{V}$ ,  $BV_{\text{DD}} = 3.3\text{V}$ ,  $V_{\text{REF}} = \text{internal } +2.5\text{V}$ ,  $f_{\text{CLK}} = 16\text{MHz}$ ,  $f_{\text{SAMPLE}} = 1\text{MSPS}$ , unless otherwise noted.

PARAMETER	CONDITION	ADS7869I			UNIT
		MIN	TYP(1)	MAX	
<b>Current Sign Comparator</b>					
Input Range	Lower Voltage of Differential Inputs	0		$V_{\text{DD}} - 1.8$	V
Offset Range			$\pm 2$	$\pm 20$	mV
Hysteresis			10	30	mV
Delay Time			25	150	ns
<b>Window Comparator</b>					
Input Range		-0.3		$V_{\text{DD}} + 0.3$	V
Offset Range			$\pm 10$	$\pm 30$	mV
Hysteresis		60	70	80	mV
Delay Time	$f_{\text{CLK}} = 16\text{MHz}$		250	375	ns
Threshold Voltage Input Range	(DAIN pin)	0.5		2.5	V

(1) All values are at  $T_A = +25^{\circ}\text{C}$ .

(2) Applies for 5.0V nominal supply:  $4.5\text{V} < BV_{\text{DD}} < 5.5\text{V}$ .

(3) Applies for 3.0V nominal supply:  $2.7\text{V} < BV_{\text{DD}} < 3.6\text{V}$ .

# Analog Motor Control Front-End with Simultaneous Sampling on Seven S/H Capacitors and Three 1MSPS, 12-Bit, 12-Channel ADCs ADS7869



SBAS253B – MAY 2003 – REVISED NOVEMBER 2004

## 1.6 PINOUT DRAWING

### TQFP Package

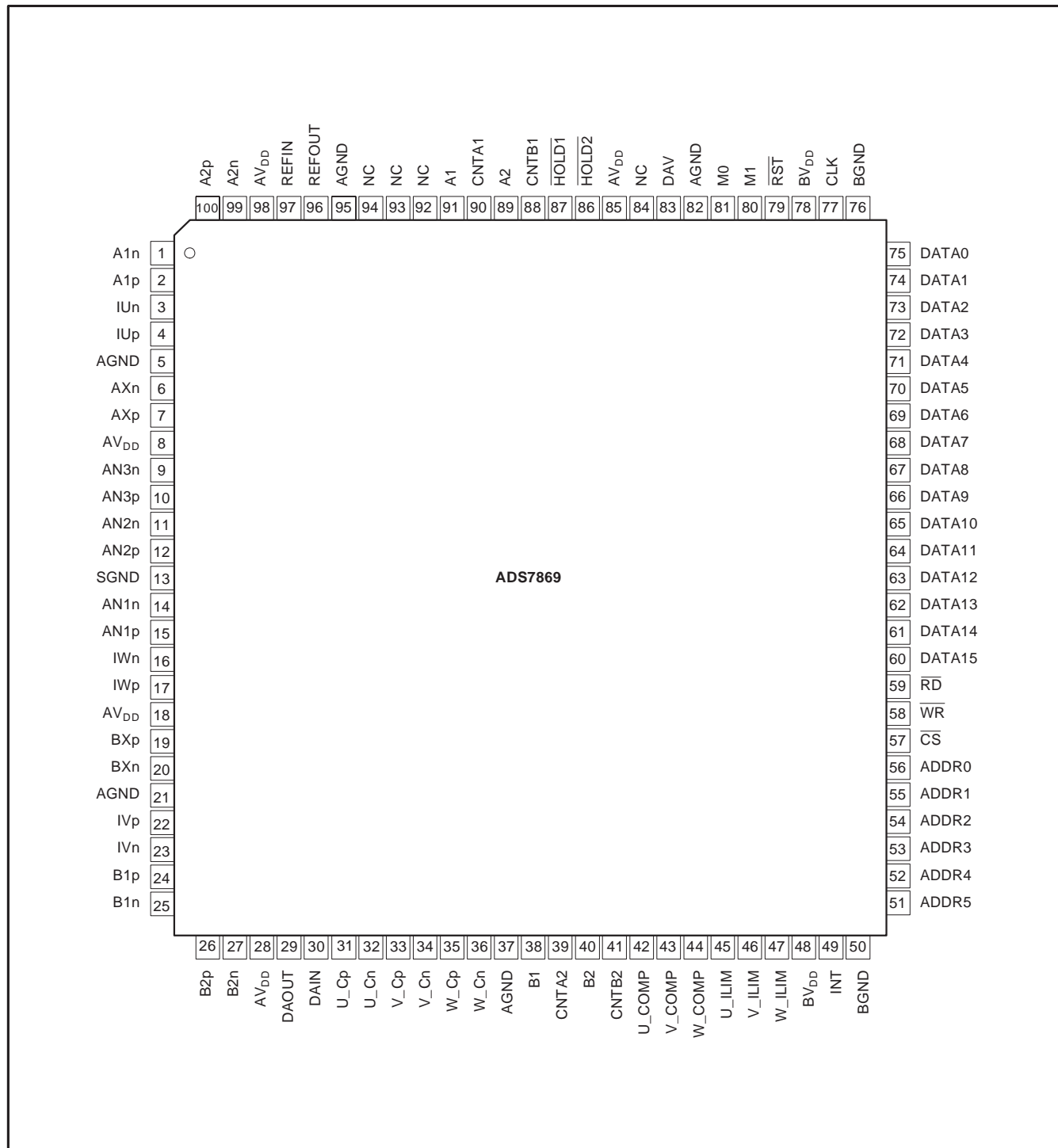

## 1.7 PIN FUNCTIONS

### TQFP Package

SIGNAL	PIN NUMBER	TYPE	DESCRIPTION
<b>ANALOG SIGNALS</b>			
<b>Analog Input Signals of Position Sensors</b>			
A1p	2	Analog In	Position Sensor 1, Analog Input of SIN, Positive Input
A1n	1	Analog In	Position Sensor 1, Analog Input of SIN, Negative Input
B1p	24	Analog In	Position Sensor 1, Analog Input of COS, Positive Input
B1n	25	Analog In	Position Sensor 1, Analog Input of COS, Negative Input
AXp	7	Analog In	Position Sensor x, Asynchronous Analog Input of SIN, Positive Input
AXn	6	Analog In	Position Sensor x, Asynchronous Analog Input of SIN, Negative Input
A2p	100	Analog In	Position Sensor 2, Analog Input of SIN, Positive Input
A2n	99	Analog In	Position Sensor 2, Analog Input of SIN, Negative Input
B2p	26	Analog In	Position Sensor 2, Analog Input of COS, Positive Input
B2n	27	Analog In	Position Sensor 2, Analog Input of COS, Negative Input
BXp	19	Analog In	Position Sensor X, Asynchronous Analog Input of COS, Positive Input
BXn	20	Analog In	Position Sensor X, Asynchronous Analog Input of COS, Negative Input
<b>Counter Signals of Position Sensors</b>			
A1	91	Digital Out	Sign of SIN Signal, Position Sensor 1
B1	38	Digital Out	Sign of COS Signal, Position Sensor 1
A2	89	Digital Out	Sign of SIN Signal, Position Sensor 2
B2	40	Digital Out	Sign of COS Signal, Position Sensor 2
CNTA1	90	Digital In	Input Signal SIN to 16-bit Up/Down Counter 1
CNTB1	88	Digital In	Input Signal COS to 16-bit Up/Down Counter 1
CNTA2	39	Digital In	Input Signal SIN to 16-bit Up/Down Counter 2
CNTB2	41	Digital In	Input Signal COS to 16-bit Up/Down Counter 2
<b>Analog Input Signals of Phase Currents</b>			
IUp	4	Analog In	Phase U Current, Positive Input
IUn	3	Analog In	Phase U Current, Negative Input
IVp	22	Analog In	Phase V Current, Positive Input
IVn	23	Analog In	Phase V Current, Negative Input
IWp	17	Analog In	Phase W Current, Positive Input
IWn	16	Analog In	Phase W Current, Negative Input

# Analog Motor Control Front-End with Simultaneous Sampling on Seven S/H Capacitors and Three 1MSPS, 12-Bit, 12-Channel ADCs ADS7869



SBAS253B – MAY 2003 – REVISED NOVEMBER 2004

## TQFP Package

SIGNAL	PIN NUMBER	TYPE	DESCRIPTION
<b>Comparator Signals of Phase Currents</b>			
DAOUT	29	Analog Out	8-Bit DAC Output for Over-Current Limit Value
DAIN	30	Analog In	Over-Current Limit Value as Input for Window Comparators
U_Cp	31	Analog In	Phase U Current Signal Input for Sign and Window Comparator, Positive Input
U_Cn	32	Analog In	Phase U Current Signal Input for Sign and Window Comparator, Negative Input
V_Cp	33	Analog In	Phase V Current Signal Input for Sign and Window Comparator, Positive Input
V_Cn	34	Analog In	Phase V Current Signal Input for Sign and Window Comparator, Negative Input
W_Cp	35	Analog In	Phase W Current Signal Input for Sign and Window Comparator, Positive Input
W_Cn	36	Analog In	Phase W Current Signal Input for Sign and Window Comparator, Negative Input
U_COMP	42	Digital Out	Sign of Phase U Current
V_COMP	43	Digital Out	Sign of Phase V Current
W_COMP	44	Digital Out	Sign of Phase W Current
U_ILIM	45	Digital Out	Over-current Output of Phase U, Active Low Output
V_ILIM	46	Digital Out	Over-current Output of Phase V, Active Low Output
W_ILIM	47	Digital Out	Over-current Output of Phase W, Active Low Output
<b>Other Analog Signals</b>			
AN(x)p	15, 12, 10	Analog In	Auxiliary Analog Input Channel (x), Positive Input
AN(x)n	14, 11, 9	Analog In	Auxiliary Analog Input Channel (x), Negative Input
REFIN	97	Analog In	Reference Voltage Input Pin
REFOUT	96	Analog Out	Reference Voltage Output Pin
NC	84, 92, 93, 94	—	No connection (should be left open)
<b>DIGITAL INTERFACE SIGNALS</b>			
ADDR(x)	56 – 51	Digital In	Address Decode Input <sup>(1)</sup>
DATA(xx)	75 – 60	Digital In/Out	Bidirectional 3-state Data Bus <sup>(1)</sup>
$\overline{\text{CS}}$	57	Digital In	Active Low Chip-Select Signal <sup>(1)</sup>
$\overline{\text{RD}}$	59	Digital In	Active Low Read Signal <sup>(1)</sup>
$\overline{\text{WR}}$	58	Digital In	Active Low Write Signal <sup>(1)</sup>
CLK	77	Digital In	System Clock
INT	49	Digital Out	Active High Interrupt Output
$\overline{\text{RST}}$	79	Digital In	Active Low Reset Input
M(x)	81, 80	Digital In	Mode Select Pins <sup>(1)</sup>
DAV	83	Digital Out	Data Available Signal
$\overline{\text{HOLD1}}$	87	Digital In	Active Low Convert Start and Synchronous Hold Signal for Sample-and-Hold Amplifiers
$\overline{\text{HOLD2}}$	86	Digital In	Active Low Asynchronous Hold Signal for Sample-and-Hold Amplifiers
<b>POWER SUPPLY</b>			
AVDD	8, 18, 28, 85, 98	Power	Analog Power Supply
BVDD	48, 78	Power	Interface Power Supply
AGND	5, 21, 37, 82, 95		Analog Ground
BGND	50, 76		Interface Ground
SGND	13		Signal Ground

(1) See *Digital* section for detailed information about the different modes.

### 1.8 BASIC CIRCUIT CONFIGURATION

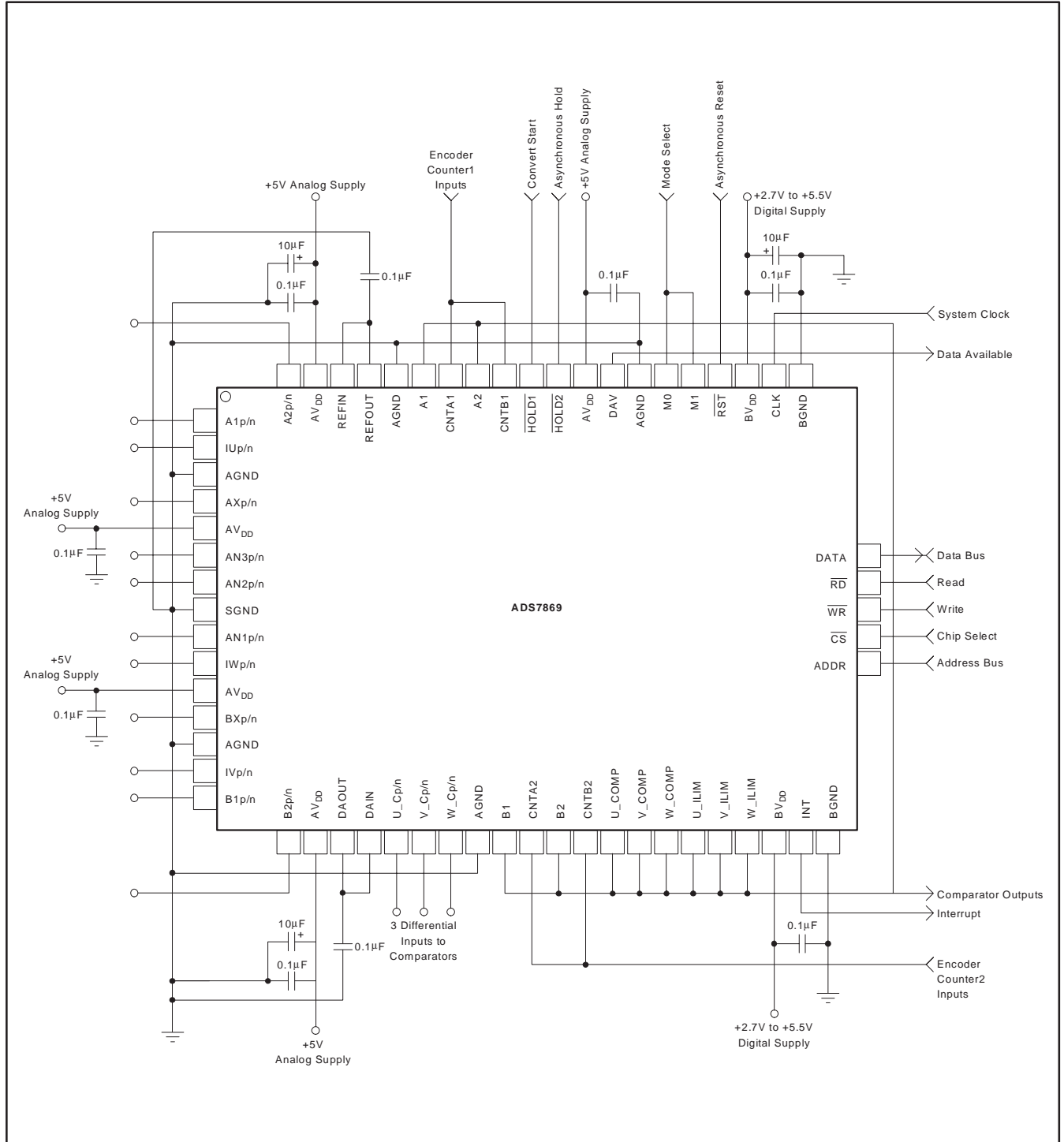

# Analog Motor Control Front-End with Simultaneous Sampling on Seven S/H Capacitors and Three 1MSPS, 12-Bit, 12-Channel ADCs ADS7869

SBAS253B – MAY 2003 – REVISED NOVEMBER 2004

## 1.9 TYPICAL APPLICATION CIRCUIT

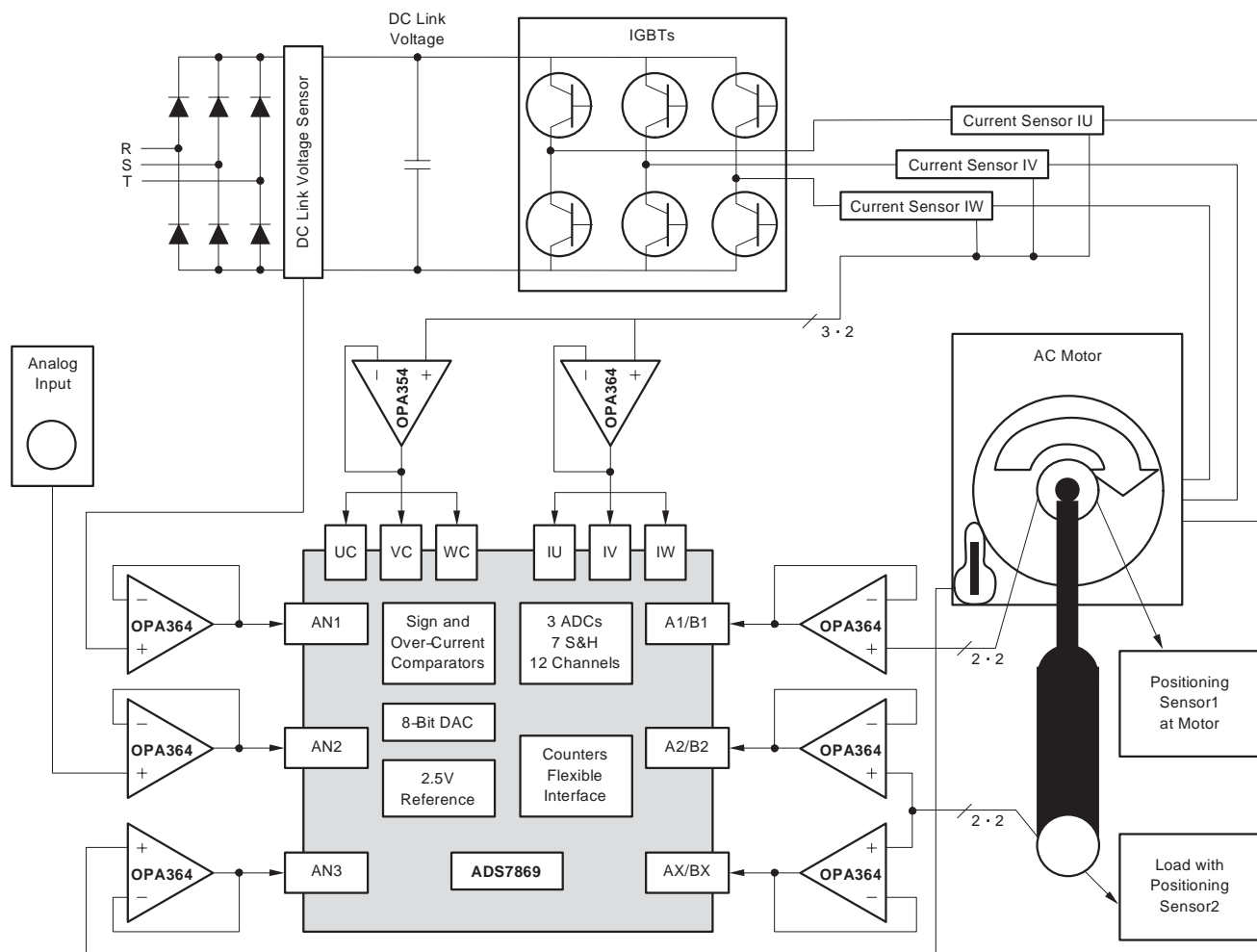

**Figure 1–1. Typical Motor Control Application**

Figure 1–1 shows an example of a typical motor control circuit. The IU, IV and IW channels measure the currents of the motor. The position (speed) of the motor and load are measured simultaneously by A1, B1 and A2, B2, respectively, using resolver or analog encoder sensors. The asynchronous inputs AX and BX can be used to capture the reference signal of encoders to derive the absolute position. Channel AN1 measures the differential DC link voltage. AN3 measures the temperature of the motor. An auxiliary voltage can be measured with channel AN2. The counter inputs connect to the appropriate comparator outputs (A1 to CNTA1, B1 to CNTB1 and so on). The level input of the window comparators, DAIN, should be connected to the 8-bit DAC output DAOUT.



### 1.10 TYPICAL CHARACTERISTICS

At  $T_A = +25^\circ\text{C}$ ,  $AV_{DD} = 5\text{V}$ ,  $BV_{DD} = 3.3\text{V}$ ,  $V_{REF} = \text{internal } +2.5\text{V}$ ,  $f_{CLK} = 16\text{MHz}$ ,  $f_{SAMPLE} = 1\text{MSPS}$ , unless otherwise noted.

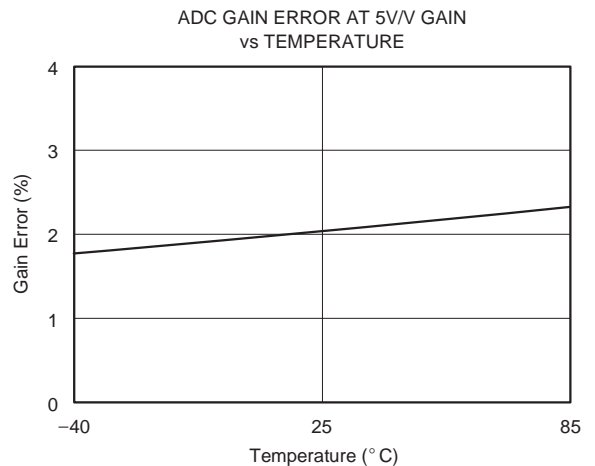
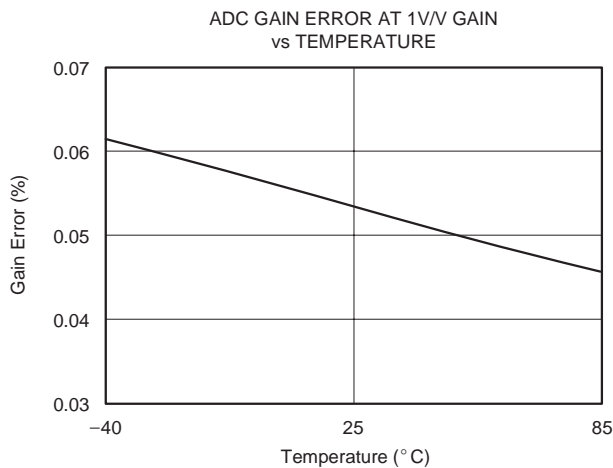
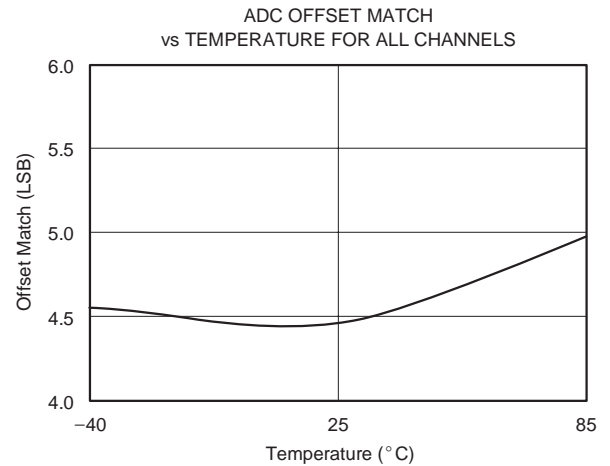
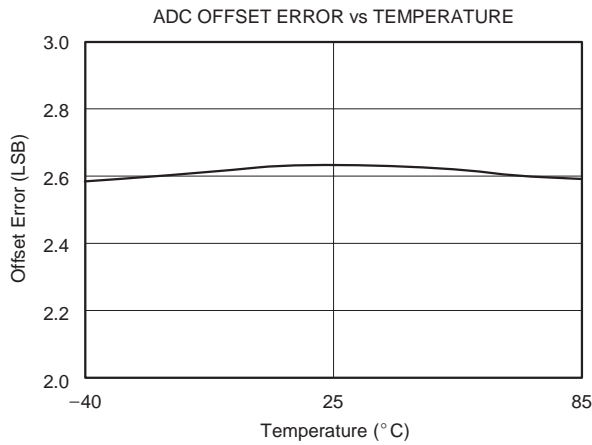
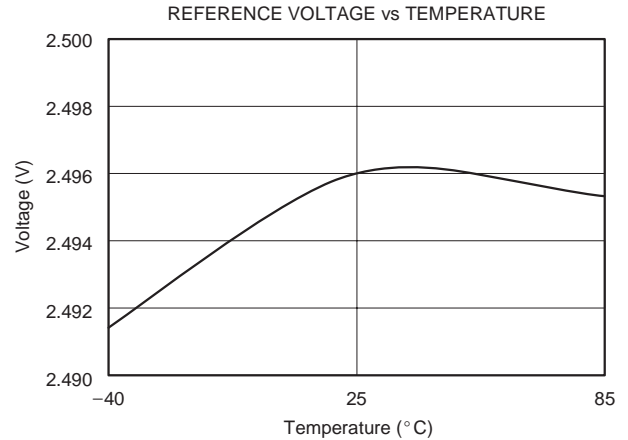
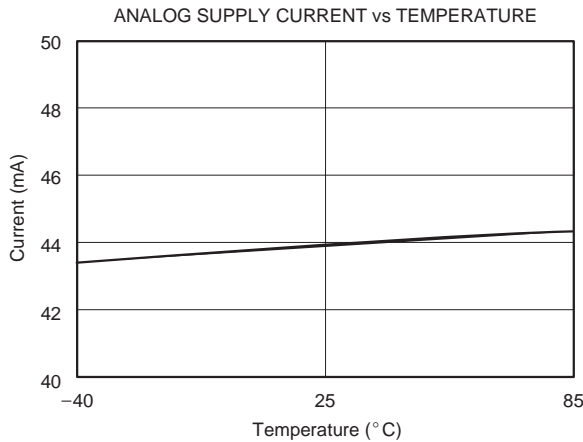

# Analog Motor Control Front-End with Simultaneous Sampling on Seven S/H Capacitors and Three 1MSPS, 12-Bit, 12-Channel ADCs ADS7869



SBAS253B – MAY 2003 – REVISED NOVEMBER 2004

## TYPICAL CHARACTERISTICS (Continued)

At  $T_A = +25^\circ\text{C}$ ,  $V_{DD} = 5\text{V}$ ,  $BV_{DD} = 3.3\text{V}$ ,  $V_{REF} = \text{internal } +2.5\text{V}$ ,  $f_{CLK} = 16\text{MHz}$ ,  $f_{SAMPLE} = 1\text{ MSPS}$ , unless otherwise noted.

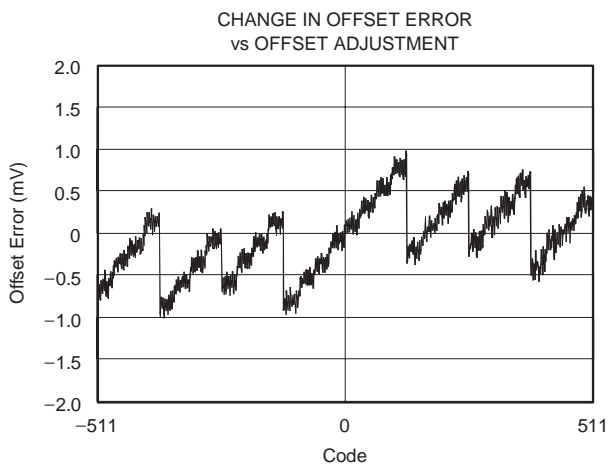
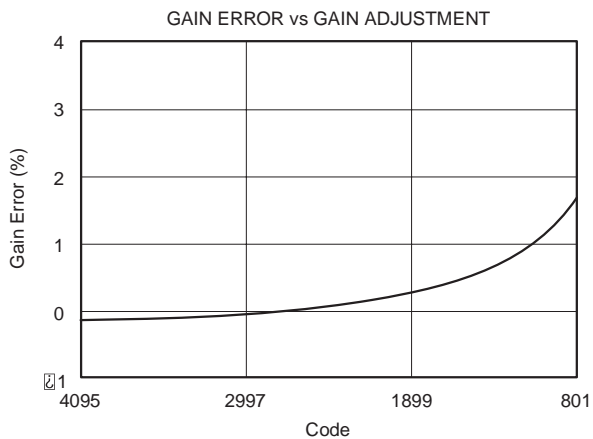
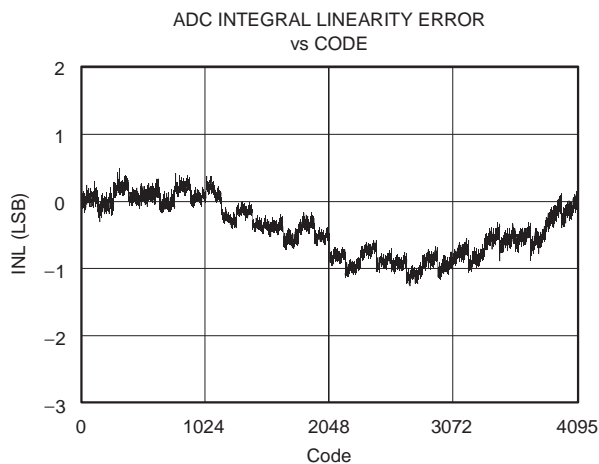
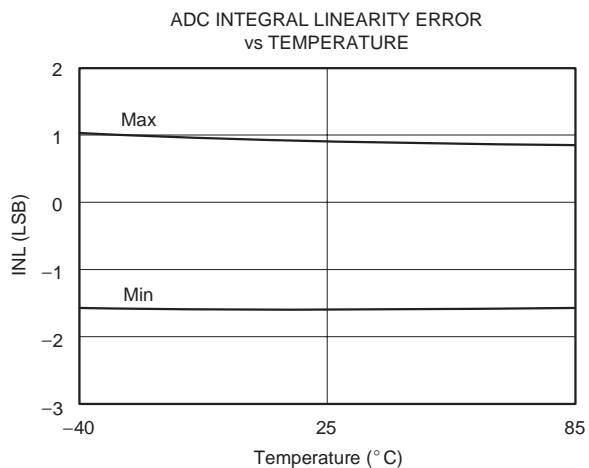
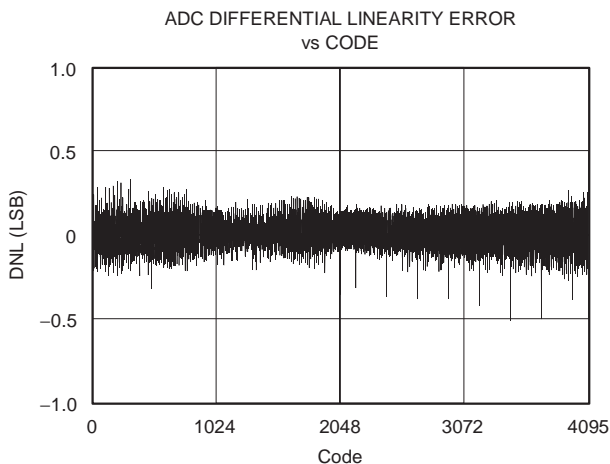
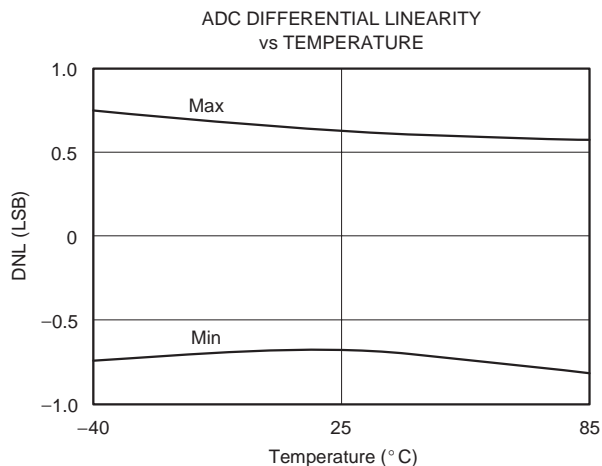

**TYPICAL CHARACTERISTICS (Continued)**

At  $T_A = +25^\circ\text{C}$ ,  $AV_{DD} = 5\text{V}$ ,  $BV_{DD} = 3.3\text{V}$ ,  $V_{REF} = \text{internal } +2.5\text{V}$ ,  $f_{CLK} = 16\text{MHz}$ ,  $f_{SAMPLE} = 1\text{ MSPS}$ , unless otherwise noted.

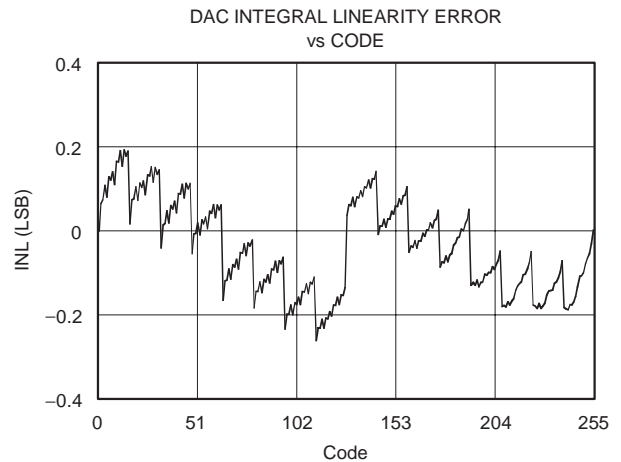
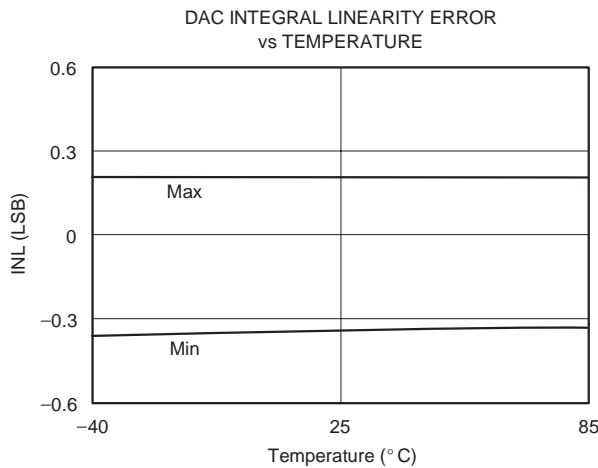
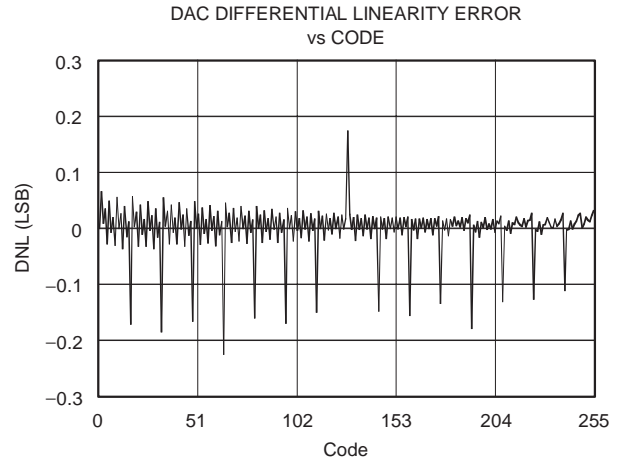
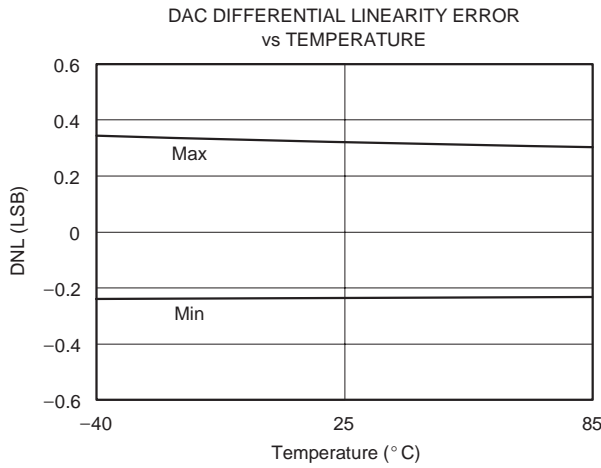
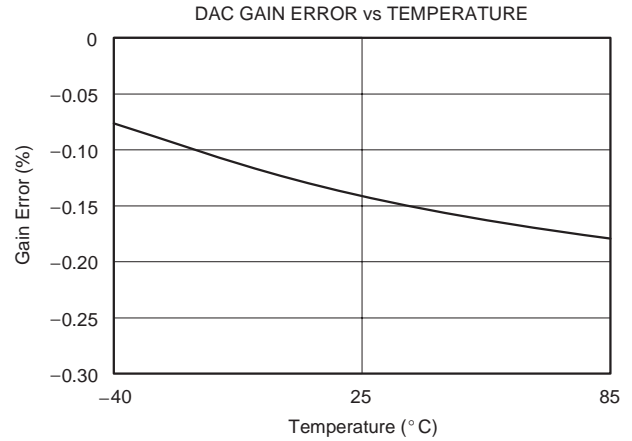
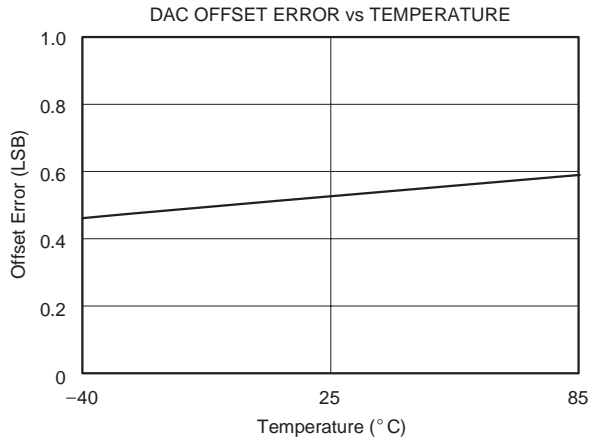

# Analog Motor Control Front-End with Simultaneous Sampling on Seven S/H Capacitors and Three 1MSPS, 12-Bit, 12-Channel ADCs ADS7869



SBAS253B – MAY 2003 – REVISED NOVEMBER 2004

## TYPICAL CHARACTERISTICS (Continued)

At  $T_A = +25^\circ\text{C}$ ,  $V_{DD} = 5\text{V}$ ,  $BV_{DD} = 3.3\text{V}$ ,  $V_{REF} = \text{internal } +2.5\text{V}$ ,  $f_{CLK} = 16\text{MHz}$ ,  $f_{SAMPLE} = 1\text{ MSPS}$ , unless otherwise noted.

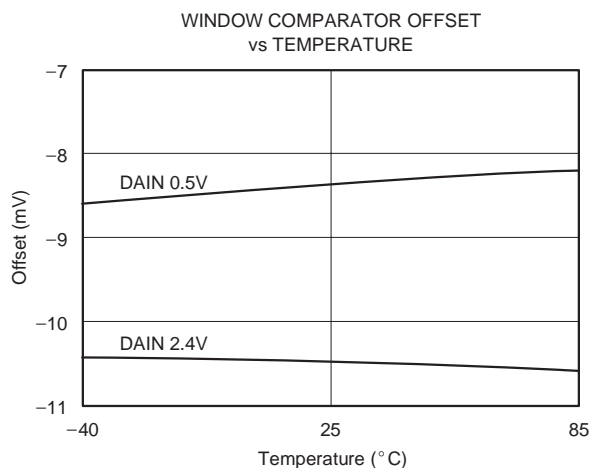
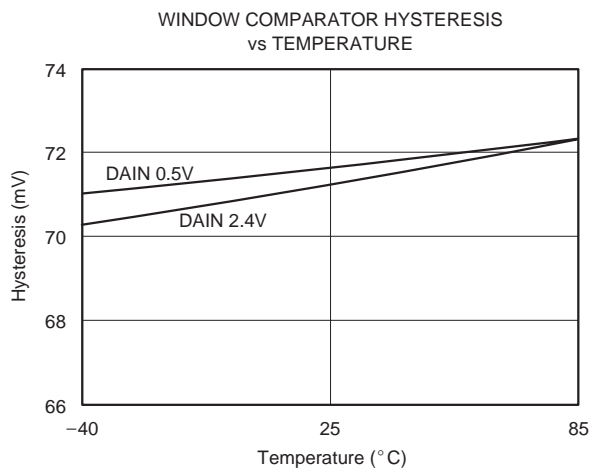
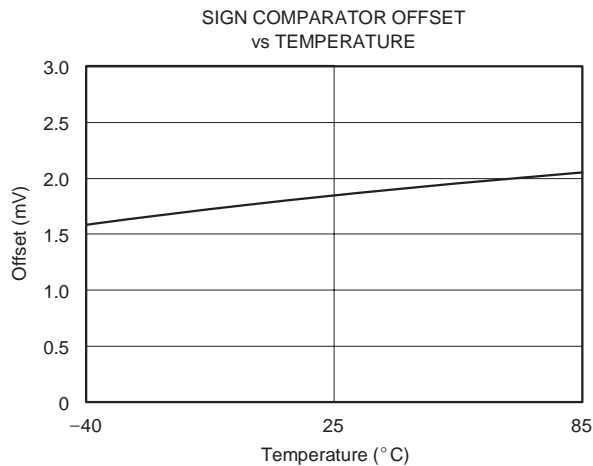
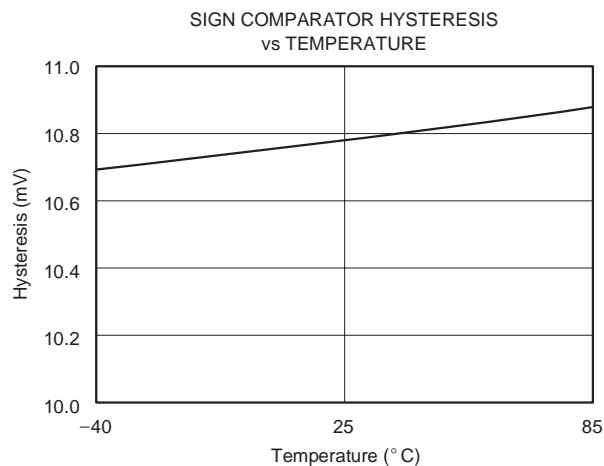
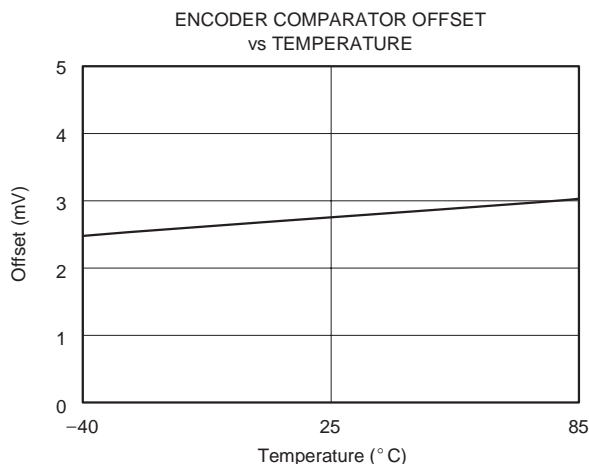
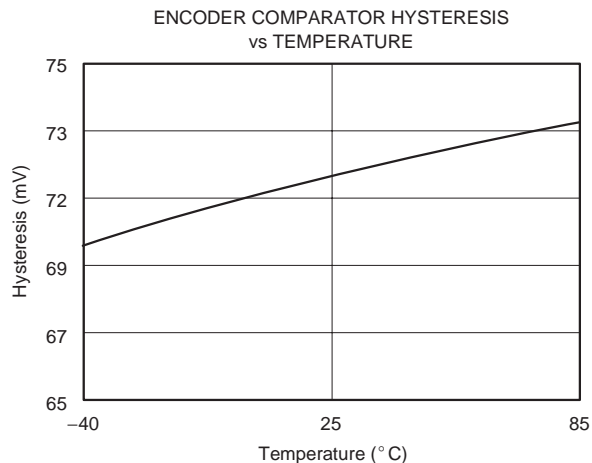

### 1.11 FUNCTIONAL BLOCK DIAGRAM

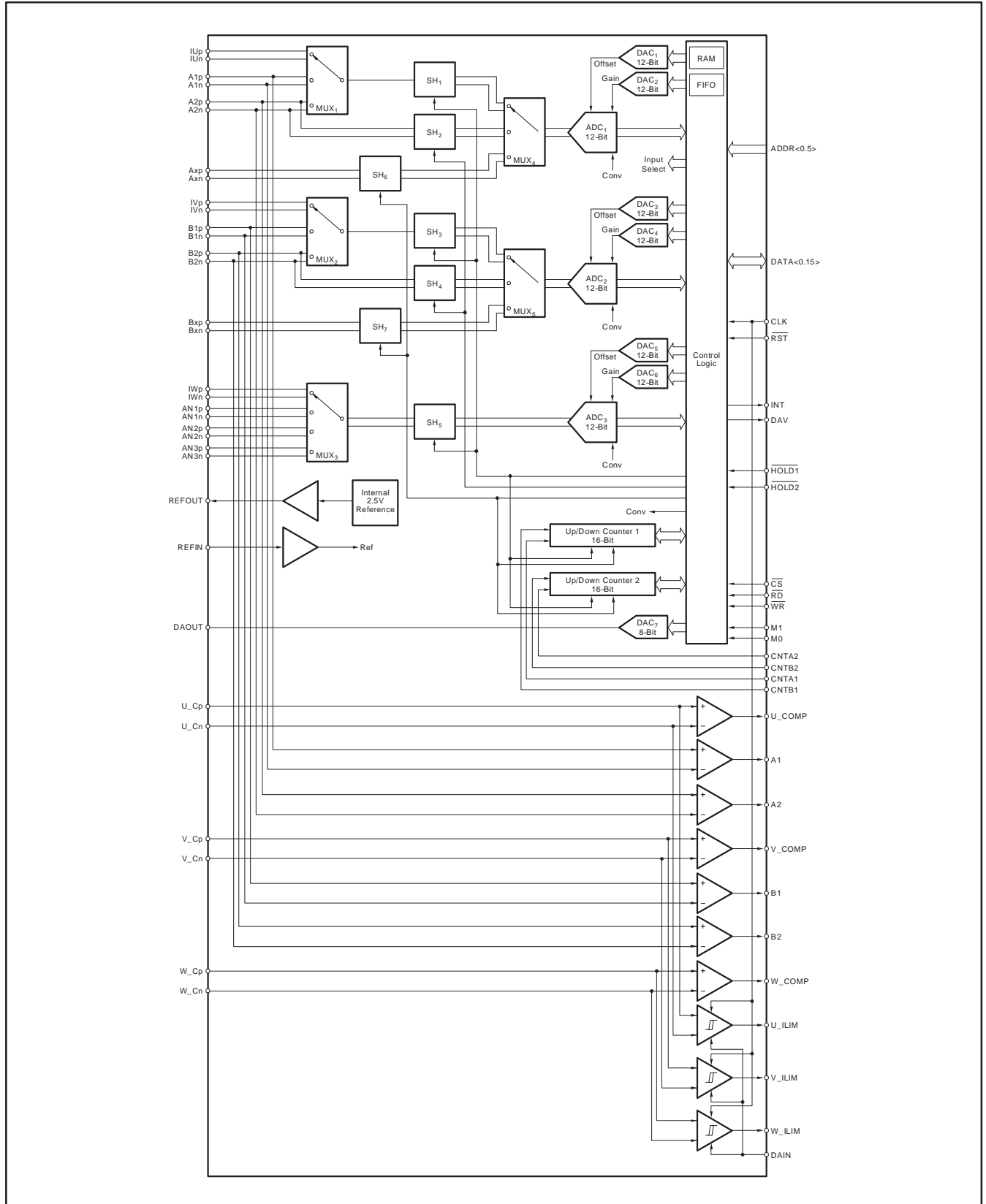

Figure 1–2. Functional Diagram

# Analog Motor Control Front-End with Simultaneous Sampling on Seven S/H Capacitors and Three 1MSPS, 12-Bit, 12-Channel ADCs ADS7869

SBAS253B – MAY 2003 – REVISED NOVEMBER 2004

## 2 Analog Section

The analog section addresses the Analog-to-Digital Converters, including the gain and offset adjustment. There is also a discussion of the analog inputs, the seven sign comparators, three window comparators, the 8-bit Digital-to-Analog Converter (DAC), the reference voltage, grounding, and the supply voltage.

### 2.1 Fully Differential Analog Inputs

#### 2.1.1 Analog-to-Digital Converter Inputs

The 12 inputs to the ADCs, as well as the three inputs (U\_C, V\_C and W\_C) to the comparators, are fully differential and provide a good common-mode rejection of 60dB at 50kHz. This is very important to suppress noise in difficult environments.

The seven sample-and-hold circuits from the ADC contain a 5pF capacitor ( $C_S$  in Figure 1–3) that is connected via a switch to the analog inputs. Opening the switch holds the data. The switch closes when the conversion is finished. The capacitor is then loaded to an initial voltage that is equal to the reference at the ADC, which is selected with the gain adjustment.

The voltage of the input pin is usually different from the voltage of the sample capacitor when the input switch closes. The sample capacitor needs to be recharged to the 12-bit accuracy, one-half of a least significant bit (LSB), within an acquisition time ( $t_{AQ}$ ) of at least 200ns.

The minimum –3dB bandwidth of the driving operational amplifier can be calculated to:

$$f_{3db} = \frac{\ln(2) \cdot (n + 1)}{2\pi \cdot t_{AQ}} \quad (1)$$

where  $n$  is equal to 12, the resolution of the ADC (in the case of the ADS7869). When  $t_{AQ} = 200$ ns, the minimum bandwidth of the driving amplifier is 7MHz. The bandwidth can be relaxed if the acquisition time is increased by the application.

The OPA364 from Texas Instruments is recommended; besides the necessary bandwidth, it provides a low offset in a small package at a low price.

The phase margin of the driving operational amplifier is usually reduced by the sampling capacitor of the ADC. A resistor between the capacitor and the amplifier reduces this effect; therefore, an internal 300Ω resistor ( $R_{SER}$ ) is in series with the switch. The resistance of the closed switch ( $R_{SW}$ ) is approximately 80Ω. See Figure 1–3.

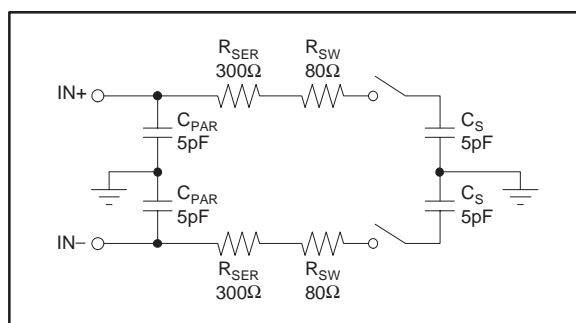

Figure 1–3. Equivalent Input Circuit to the ADCs

The differential input range (positive minus negative input) of the ADC is  $\pm REF\_ADC$ , the reference of the converter, which is selected with the gain adjustment.

It is important that the voltage to all inputs does not exceed more than 0.3V above the analog supply or 0.3V below the ground. There is no DC current flow through the inputs. Current is only necessary when recharging the sample-and-hold capacitors,  $C_S$ .

### 2.1.2 Window Comparator Inputs

A sampling architecture was selected for the window comparators. The sampling time is two clock cycles with a minimum  $t_{AQ}$  (see Equation 1) of 125ns. The necessary accuracy is 10mV (see 8-bit DAC section) with a 5V input range. The required bandwidth of the driving amplifier is 8.8MHz (see Equation 1). The OPAx354 from Texas Instruments is recommended.

The input circuit of the window comparator is similar to the ADC inputs. The only difference is that the sampling capacitors are reduced to 2.5pF. (See Figure 1–4.)

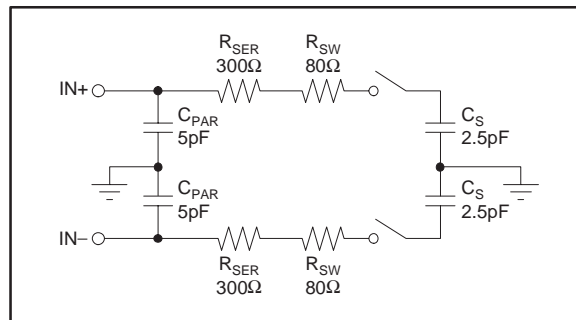

Figure 1–4. Equivalent Input Circuit of the Window Comparators

### 2.1.3 Sign Comparator Inputs

Four sign comparators are connected to the ADC inputs (A1, B1, A2 and B2); three of the sign comparators are wired to the window comparator inputs (U\_C, V\_C, and W\_C).

The sample capacitors of the ADCs and the window comparators could produce voltage glitches; therefore, it is important to drive the inputs with low impedance.

The lower voltage of the differential input should remain within the range of 0 to  $AV_{DD}-1.8V$ .

## 2.2 Analog-To-Digital Converter

The ADS7869 includes three, SAR-type, 1MSPS, 12-bit ADCs, and three pairs of S/H capacitors, which are each connected to ADC<sub>1</sub> and ADC<sub>2</sub>. A single S/H capacitor is connected to ADC<sub>3</sub>. Gain and offset adjustments are added to each ADC. (See Figure 1–2 on page 15.)

### 2.2.1 $\overline{HOLD1}$ , $\overline{HOLD2}$

The analog inputs are held when the  $\overline{HOLDx}$  signals go low. The charges of the synchronous sample-and-holds (S/H<sub>1–5</sub>) are frozen on the falling edge of  $\overline{HOLD1}$ . The setup time of  $\overline{HOLD1}$ , against the rising edge of the system clock, is typically 25ns. The conversion will automatically start on the next rising edge of the clock. The S/Hs are switched back into the sample mode when the conversion is finished, 12 clock cycles later. This point of time is indicated by DAV. (See Figure 1–10 on page 26.)  $\overline{HOLD1}$  must go high at the latest at the 13th falling clock after conversion start.

The asynchronous sample and holds (S/H<sub>6–7</sub>) are triggered by the active low  $\overline{HOLD2}$  signal. The setup time of  $\overline{HOLD2}$ , against the falling edge of  $\overline{HOLD1}$ , is 0ns; see Figure 1–10. The conversion of these S/H circuits is initiated when they are selected through the digital interface and the  $\overline{HOLD1}$  signal goes low. The inputs are connected back to the S/H capacitor when the  $\overline{HOLD2}$  signal goes high.  $\overline{HOLD2}$  needs to be low during the whole conversion. It is possible to connect  $\overline{HOLD1}$  and  $\overline{HOLD2}$  together.

# Analog Motor Control Front-End with Simultaneous Sampling on Seven S/H Capacitors and Three 1MSPS, 12-Bit, 12-Channel ADCs ADS7869



SBAS253B – MAY 2003 – REVISED NOVEMBER 2004

---

## 2.2.2 Clock

The ADC uses the external clock CLK, which needs to be in the range of 1MHz to 16MHz. 12 clock cycles are necessary for a conversion, with a minimum of four clock cycles for the acquisition. Therefore, the maximum throughput rate of 1MSPS is achieved with a 16MHz clock and 16 clock cycles per complete conversion cycle. The duty cycle should be 50%; however, the ADS7869 will still function properly with a duty cycle between 30% and 70%.

## 2.2.3 Reset

A reset condition stops any ongoing conversion and reconnects the synchronous S/Hs to the inputs; see the *Reset* Section.

## 2.2.4 Gain Adjustment

The output of a 12-bit DAC (REF\_ADC) is used as the reference voltage for the ADC. There is one DAC for each ADC. The voltage range is between 0V (code 000<sub>H</sub>) and the 2.5V of REFIN (code FFF<sub>H</sub>). The ADC operates correctly if the selected voltage is in the range of 0.5V to 2.5V. The output voltage of the DAC sets the differential input range of the ADC, which is  $\pm$ REF\_ADC. The desired input range can be adjusted in 1.22mV steps.

In the VECANA mode, the gain information contained in the digital input word ADIN automatically sets the DAC value. See the *Vecana Interface* section for further information.

In all other modes, there is a register for every input channel inside the digital interface, which stores the gain information for any given channel. When a particular channel is selected by the application, the value of this register is automatically written to the DAC and the DAC output is adjusted to the desired value. The DAC settles to this value within 250ns (equivalent to the minimum acquisition time).

The gain information inside the registers is set to zero when a reset condition occurs. These registers need to be set to the selected value before the ADCs are used.

In VECANA mode, the DAC is initially set to Full-Scale and the differential input range is equal to  $\pm$ (voltage at the REFIN pin).

## 2.2.5 Offset Adjustment

The offset can be adjusted, similar to the gain, to a 12-bit level with respect to the actual input voltage range of the ADC. For example, if the input range is  $\pm$ 1V, the offset can be adjusted in increments of 488 $\mu$ V. The maximum adjustment is  $\pm$ 12.5% of the input range.

There is a register inside the digital interface for each input channel. This registers store the offset adjustment value for each channel. When a channel is selected for conversion, the offset is automatically adjusted. The selected channel and the related register information must not be changed during the conversion.

Setting the register to 201<sub>H</sub> results in a  $-12.5\%$  adjustment, 000<sub>H</sub> results in no adjustment, and 1FF<sub>H</sub> results in a  $+12.5\%$  adjustment. The offset adjustment value 200<sub>H</sub> is not allowed.

The offset adjustment cannot be used in VECANA mode. A reset condition will set the offset adjustment to zero.



### 2.2.6 Transition Noise

The transition noise of the ADS7869 itself is low, as shown in Figure 1–5. Applying a low-noise DC input and initiating 8000 conversions generated this histogram.

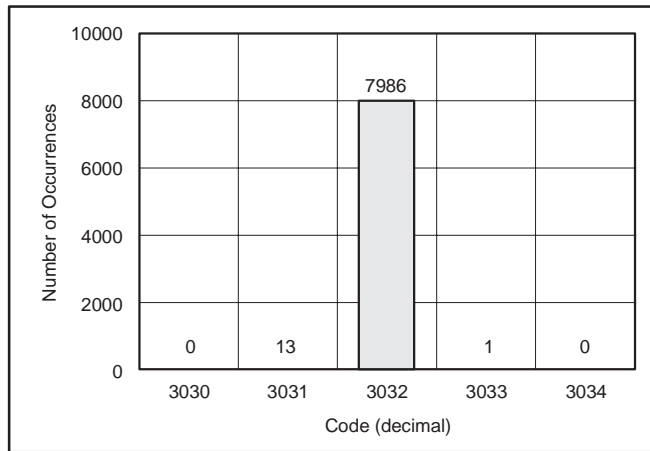

**Figure 1–5. Histogram of 8000 Conversions**

### 2.3 Sign Comparators

The ADS7869 includes two sets of sign comparators that differ in their hysteresis. The first set, which is used for the position sensor inputs in motor control applications, is connected to the inputs A1, B1, A2, and B2. The hysteresis of these comparators is typically 75mV. In motor control applications, these comparators are used to measure the signs of the position sensor input signals.

The second set is in parallel to the window comparators at the U\_C, V\_C, and W\_C pins. The hysteresis of these components is typically 10mV. In motor control applications, these comparators are used to measure the sign of the main currents.

The sign comparator switches from 0 to 1 if the differential input voltage is above  $+1/2$  of the hysteresis. If the output is 1, the sign comparator switches back to 0 if the differential input voltage is below  $-1/2$  of the hysteresis. See Figure 1–6.

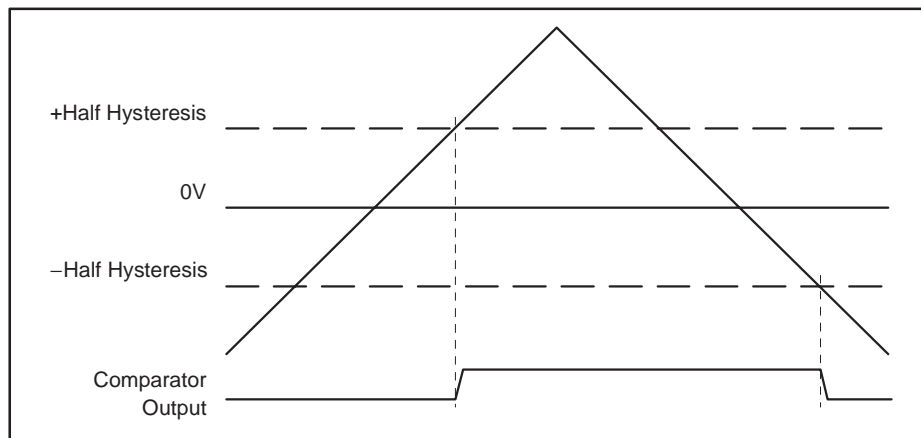

**Figure 1–6. Typical Transfer Function of a Sign Comparator**

# Analog Motor Control Front-End with Simultaneous Sampling on Seven S/H Capacitors and Three 1MSPS, 12-Bit, 12-Channel ADCs ADS7869

SBAS253B – MAY 2003 – REVISED NOVEMBER 2004

The input range of the comparators is limited. The lower voltage of the differential inputs should always be within the range of 0 to  $AV_{DD}-1.8V$ .

On every comparator, the output is delayed to the input voltage. This delay is dependent on the overdrive of the comparator inputs. The overdrive is the input voltage ( $V_{IN}$ ) minus one-half of the hysteresis.

If the differential input voltage of the position sensor sign comparator is switching from  $-40mV$  to  $+40mV$  (step function,  $2.5mV$  overdrive), then the delay time of the output is typically  $100ns$ . The delay is reduced to typically  $25ns$  if the comparator is switching between  $-100mV$  and  $+100mV$  ( $72.5mV$  overdrive). For the delay times as a function of step size with different overdrives, see Figure 1–7 and Figure 1–8.

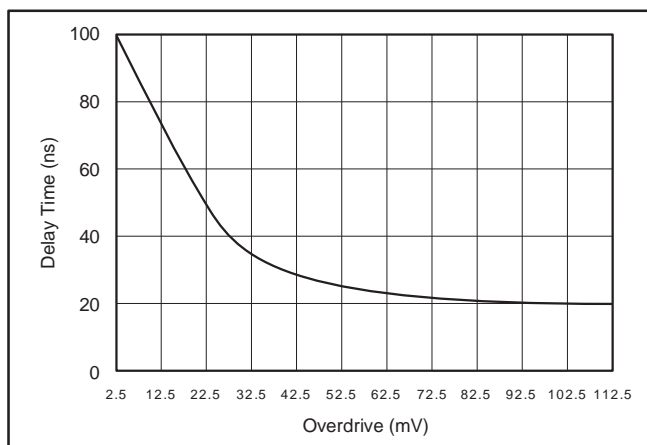

Figure 1–7. Position Sensor Comparator Overdrive

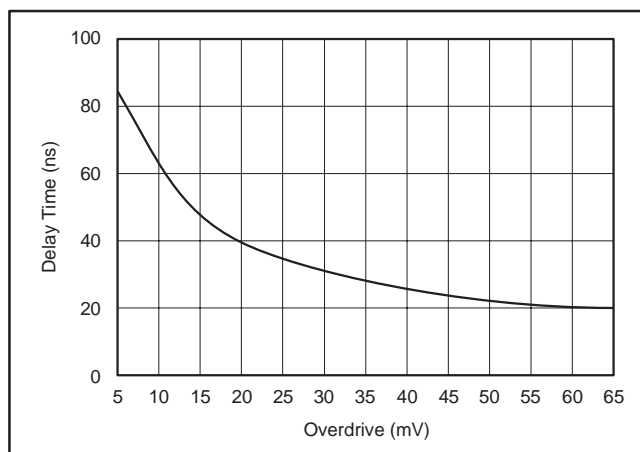
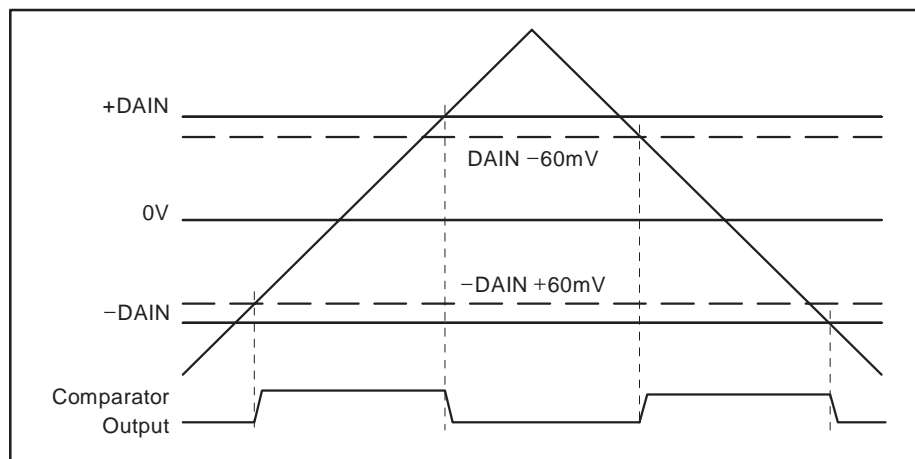

Figure 1–8. Current Sign Comparator Overdrive

## 2.4 Window Comparators

The window comparators test if the input voltage is within a certain range; this range is  $\pm$ (voltage applied to DAIN, pin 30). If the differential input voltage remains within this range, then the output of the window comparator is 1. If the voltage is outside this range, then the output is set to 0. The window comparator has a hysteresis that is turned on when the output is 0. The comparator outputs switch back to 1 when the input voltage is within the range of  $\pm$ (DAIN –60mV). (See Figure 1–9.) The voltage at DAIN needs to be in a range of 0.5V to 2.5V.

The window comparator has a switched capacitor circuitry, similar to the ADC architecture, but different from other window comparators. This design dramatically increases the accuracy; due to the additional accuracy, a proper front-end of the input signal is required. (See the *Window Comparator Inputs* section.)



**Figure 1–9. Typical Transfer Function of a Window Comparator**

Two clock cycles are used to sample the inputs. The next two clock cycles are used to test the lower and the upper voltage limit. Every four clock cycles (or every 250ns with a 16MHz clock) the output of the window comparator is updated. In a worst-case scenario, it takes six clock cycles for the window comparator to detect a current limit. The window comparators need a continuous clock to operate properly.

In motor control applications, the window comparators are used to monitor the main currents for failures.

# Analog Motor Control Front-End with Simultaneous Sampling on Seven S/H Capacitors and Three 1MSPS, 12-Bit, 12-Channel ADCs ADS7869



SBAS253B – MAY 2003 – REVISED NOVEMBER 2004

## 2.5 8-Bit Digital-to-Analog Converter

A voltage between 0.5V to 2.5V is required at DAIN (pin 30) to set the range of the window comparators; this can be accomplished with the 8-bit DAC. The DAC value is programmed via the digital interface. Input code 00<sub>H</sub> corresponds to a DAC output voltage of 0V. The full-scale value (FF<sub>H</sub>) is at 2.49V (internal reference minus 1LSB).

The impedance of the output is typically 10k $\Omega$ ; the output impedance is independent of the output voltage. The DAC output is connected to DAOUT (pin 29). The settling time ( $t_s$ ) is dependent on the external capacitance ( $C_e$ ) on this pin, and can be calculated to:

$$t_s = 10k\Omega \cdot C_e \cdot (n + 1) \cdot \ln(2) \quad (2)$$

In this equation,  $n$  is equal to 8, the resolution of the DAC. The output impedance also limits the output current. This current should not exceed 0.5 $\mu$ A (0.5 $\mu$ A $\cdot$ 10k $\Omega$  = 5mV).

DAOUT and DAIN can be shorted. A capacitor (typically 0.1 $\mu$ F) can be used to low-pass the DAC output; however, this low-pass configuration is not required.

## 2.6 Internal Reference

The internal reference, REFOUT (pin 96), provides the 2.5V required for the reference input of the ADCs at REFIN (pin 97). An internal buffer with a high impedance output drives the reference output pin. This internal buffer is optimized to reject glitches at the reference pin. Any capacitor can be connected to the REFOUT pin in able to reduce noise. It is recommended that a 0.1 $\mu$ F capacitor be connected between the REFOUT (pin 96) and the SGND (pin 13). The Signal ground, SGND, is used internally as a negative reference. The reference voltage is considered a differential voltage between this ground and REFOUT.

Normally, the REFOUT and REFIN pins are both shorted. The internal reference provides an excellent temperature drift, typically 20ppm, and an initial accuracy of 2.5V $\pm$ 20mV at 25 $^{\circ}$ C. If this does not provide the required accuracy for an application, then an external reference can be connected to the REFIN pin.

## 2.7 Grounding

Optimal test results were achieved with a solid ground plane: linearity, offset, and noise performance each showed improvement. During PCB layout, care should be taken that the return currents do not cross any sensitive areas or signals.

Digital signals that interface with the ADS7869 are referenced to the solid ground plane. ESD protection diodes, inside the ADS7869, start conducting if the grounds are separated and the digital inputs go below –0.3V; this includes short glitches. Current will flow through the substrate of the ADS7869 and will disturb the analog performance.

## 2.8 Supply

The ADS7869 has two separate supplies, BV<sub>DD</sub> (pins 48 and 78) and AV<sub>DD</sub> (pins 8, 18, 28, 85 and 98).

BV<sub>DD</sub> is used as a digital pad supply only, and is in the range of 2.7V to 5.5V. This allows the ADS7869 to interface with all state-of-the-art processors and controllers. BV<sub>DD</sub> should be filtered in order to limit the noise energy from the external digital circuitry to the ADS7869. The current through BV<sub>DD</sub> is far below 5mA; depending on the external load, a 10 $\Omega$  to 100 $\Omega$  resistor can be placed between the external digital circuitry and the ADS7869. Bypass capacitors (two 0.1 $\mu$ F and one 10 $\mu$ F) should be placed between the two BV<sub>DD</sub> pins and the ground plane.

AV<sub>DD</sub> supplies the internal circuitry, and can vary from 4.5 to 5.5V. It is not possible to use a passive filter between the digital board supply of the application and the AV<sub>DD</sub> pins, because the supply current of the ADS7869 is typically 45mA. In order to generate the analog supply voltage for the ADS7869 and the necessary analog front-end, a linear regulator (7805 family) is recommended. Bypass capacitors of 0.1 $\mu$ F should be placed between all AV<sub>DD</sub> pins and the ground plane. Bypass capacitors of 10 $\mu$ F should be placed between two AV<sub>DD</sub> pins and the ground plane.

### 3 Digital Section

#### 3.1 Introduction

The ADS7869 can interface with a DSP or  $\mu$ C in four different ways. The M1 and M0 pins determine in which mode the ADS7869 will communicate; see Table 1–1. It can be connected as a standard VECANA01 interface, as an SPI, or as two different parallel interfaces.

**Table 1–1. Selection of Interface Mode**

M1	M0	MODE
0	0	VECANA mode
0	1	SPI mode
1	0	Parallel 1
1	1	Parallel 2

As a function of the selected mode, some pins will have different assignment as shown in Table 1–2.

**Table 1–2. Mode vs Pin Functions**

Pin No. 80, 81 (M1, M0)	VECANA Mode <sup>(1)</sup>		SPI <sup>(1)</sup>	Parallel 1	Parallel 2
	00		01	10	11
56	NC		NC	ADDR0 (LSB)	ADDR0 (LSB)
55	NC		NC	ADDR1	ADDR1
54	NC		NC	ADDR2	ADDR2
53	S1		NC	ADDR3	ADDR3
52	S0		NC	ADDR4	ADDR4
51	WINCLK		NC	ADDR5 (MSB)	ADDR5 (MSB)
75	NC		NC	DATA0 (LSB)	DATA0 (LSB)
74	NC		NC	DATA1	DATA1
73	NC		NC	DATA2	DATA2
72	NC		NC	DATA3	DATA3
71	NC		NC	DATA4	DATA4
70	ADOUT1	ADOUT1 <sup>(3)</sup>	NC	DATA5	DATA5
69	ADOUT2	ADOUT2 <sup>(3)</sup>	NC	DATA6	DATA6
68	ADOUT3	ADOUT3 <sup>(3)</sup>	SPISOMI	DATA7	DATA7
67	ADIN	ADIN <sup>(3)</sup>	SPISIMO	DATA8	DATA8
66	NC		SPICLK	DATA9	DATA9
65	NC		NC	DATA10	DATA10
64	NC		NC	DATA11	DATA11
63	NC		NC	DATA12	DATA12
62	NC		NC	DATA13	DATA13
61	NC		NC	DATA14	DATA14
60	NC		NC	DATA15 (MSB)	DATA15 (MSB)
57	NC		SPISTE	CS	CS
59	NC		NC	R/W	RD / – <sup>(2)</sup>
58	NC		NC	WE	WR / R/W <sup>(2)</sup>
77	CLK	ADCLK <sup>(3)</sup>	CLK	CLK	CLK
79	RST		RST	RST	RST
49	NC		INT	INT	INT
83	DAV	ADBUSY <sup>(3)</sup>	DAV	DAV	DAV
87	HOLD1	ADCONV <sup>(3)</sup>	HOLD1	HOLD1	HOLD1
86	HOLD2	NPSH <sup>(3)</sup>	HOLD2	HOLD2	HOLD2

(1) NC means no connection. The NC pins in VECANA01 and SPI modes should be grounded with a pull-down resistor.

(2) For parallel mode 11 there is one sub-mode for compatibility with the TMS320c54xx DSP family; see *Mode 11 Bus Access* (TMS320c54xx DSP family-compatible mode) section.

(3) Original VECANA01 pin names.

# Analog Motor Control Front-End with Simultaneous Sampling on Seven S/H Capacitors and Three 1MSPS, 12-Bit, 12-Channel ADCs ADS7869



SBAS253B – MAY 2003 – REVISED NOVEMBER 2004

## 3.2 VECANA Interface

The VECANA01 mode of the ADS7869 interface acts exactly like the original VECANA01 interface. This mode was added to the ADS7869 for backward-compatibility purposes.

Sampling and conversion are controlled with the  $\overline{\text{HOLD1}}$  and CLK inputs. The ADS7869 is designed to operate with an external clock supplied to the CLK input. This allows the conversion to be synchronous with the system clock, thus reducing transient noise effects. The DAV signal indicates when a conversion is taking place with a low-level pulse. The DAV signal is equivalent to the ADBUSY signal in the VECANA01.

The typical clock frequency for the specified accuracy is 16MHz. This results in a complete conversion cycle, S/H acquisition and analog-to-digital (A/D) conversion of 1 $\mu$ s. It is possible to stop the clock after 14 clock cycles and start it again when the next conversion starts (after  $\overline{\text{HOLD1}}$  goes low); see the *WINCLK Selection* section.

When power is applied to the ADS7869, one conversion cycle is required for initialization before valid digital data is transmitted on the second cycle. The first conversion after power is applied is performed with indeterminate configuration values in the Input Setup Register. The second conversion uses those values to perform proper conversions and to output valid digital data from each of the ADCs.

The setup word received by the ADS7869 is used for the next conversion cycle while the ADCs are converting and transmitting their serial digital data for one conversion cycle. The 13-bit word is supplied to ADIN (pin 67), and is stored in the buffered Input Setup Register.

Configuration parameters are:

- DAC output voltage;
- Programmable gain/input voltage range;
- Input multiplexer; and
- sample-and-hold selection.

The DAC Input portion of the ADIN word (bits DAC [7...0]) determines the value of the DAC output voltage; see Table 1–5. The 8-bit DAC has 256 possible output steps from 0V to +2.490V. The value of 1LSB is 9.76mV (see Table 1–3 for input/output relationships).

Table 1–3 to Table 1–6 show information regarding these parameters.

**Table 1–3. DAC Input/Output Relationships**

DAC Input Code		Analog Output
00 <sub>H</sub>	0000 0000 <sub>B</sub>	0V
01 <sub>H</sub>	0000 0001 <sub>B</sub>	+0.010V
...	...	...
...	...	...
FF <sub>H</sub>	1111 1111 <sub>B</sub>	+2.490V

**Table 1–4. VECANA Gain Select Information**

Gain Select Bits	Gain Setting	Input Voltage Range
0 <sub>H</sub>	5.0V/V	±0.5V
1 <sub>H</sub>	2.5V/V	±1.0V
2 <sub>H</sub>	1.25V/V	±2.0V
3 <sub>H</sub>	1.0V/V	±2.5V

The Gain Select portion (bits GAIN [1..0]) determines the programmable gain of the ADIN word; see Table 1–5. The gain for all three ADCs is set by one gain input parameter. The gain values and allowable full-scale inputs are shown in Table 1–4.

The gain setting and input voltage range for the channels AN1, AN2, and AN3 at ADC3 are always 1.0V/V with respect to  $\pm 2.5V$ .

**Table 1–5. 13-bit VECANA ADIN Word Format**

D12	D11	D10	D9	D8	D7	D6	D5	D4	D3	D2	D1	D0
DAC7	DAC6	DAC5	DAC4	DAC3	DAC2	DAC1	DAC0	GAIN1	GAIN0	IN2	IN1	IN0

### 3.2.1 Input Channel Selection

Table 1–6 shows the relationships between the value of the input select bits and the input channels that are converted.

**Table 1–6. Controls for Input Multiplexers and Sample Holds**

INPUT SELECT, BITS 2–0		ANALOG SIGNAL CONNECTED TO ADC <sub>X</sub>					
HEX CODE	BINARY CODE	ADC <sub>1</sub>		ADC <sub>2</sub>		ADC <sub>3</sub>	
0 <sub>H</sub>	000	—	—	—	—	AN3	SH <sub>5</sub>
1 <sub>H</sub>	001	AX	SH <sub>6</sub>	BX	SH <sub>7</sub>	AN3	SH <sub>5</sub>
2 <sub>H</sub>	010	A2	SH <sub>1</sub>	B2	SH <sub>3</sub>	AN2	SH <sub>5</sub>
3 <sub>H</sub>	011	A2	SH <sub>2</sub>	B2	SH <sub>4</sub>	AN2	SH <sub>5</sub>
4 <sub>H</sub>	100	A1	SH <sub>1</sub>	B1	SH <sub>3</sub>	AN1	SH <sub>5</sub>
5 <sub>H</sub>	101	A1	SH <sub>1</sub>	B1	SH <sub>3</sub>	AN1	SH <sub>5</sub>
6 <sub>H</sub>	110	A1	SH <sub>1</sub>	B1	SH <sub>3</sub>	AN1	SH <sub>5</sub>
7 <sub>H</sub>	111	IU	SH <sub>1</sub>	IV	SH <sub>3</sub>	IW	SH <sub>5</sub>

#### Input Select = 0<sub>H</sub>

The synchronous sample-and-hold, SH<sub>5</sub>, samples AN3 (only), then ADC3 converts it on the signal  $\overline{\text{HOLD1}}$ .

#### Input Select = 1<sub>H</sub>

AX is sampled by the asynchronous sample-and-hold, SH<sub>6</sub>, with the signal  $\overline{\text{HOLD2}}$ ; ADC1 converts it on the signal  $\overline{\text{HOLD1}}$ . BX is sampled by the asynchronous sample-and-hold, SH<sub>7</sub>, with the signal  $\overline{\text{HOLD2}}$ ; ADC2 converts it on the signal  $\overline{\text{HOLD1}}$ . AN3 is sampled by the synchronous sample-and-hold, SH<sub>5</sub>, then ADC3 converts it on the signal  $\overline{\text{HOLD1}}$ .

The signal  $\overline{\text{HOLD2}}$  must be low during the entire conversion. If  $\overline{\text{HOLD2}}$  is high before a conversion starts, ADC<sub>1</sub> and ADC<sub>2</sub> will not convert.

#### Input Select = 2<sub>H</sub>

A2 is sampled by the synchronous sample-and-hold, SH<sub>1</sub>; ADC<sub>1</sub> converts it on the signal  $\overline{\text{HOLD1}}$ . B2 is sampled by the synchronous sample-and-hold, SH<sub>3</sub>; ADC<sub>2</sub> converts it on the signal  $\overline{\text{HOLD1}}$ . AN2 is sampled by the synchronous sample-and-hold, SH<sub>5</sub>; ADC<sub>3</sub> converts it on the signal  $\overline{\text{HOLD1}}$ .

#### Input Select = 3<sub>H</sub>

A2 is converted by ADC<sub>1</sub> on the signal  $\overline{\text{HOLD1}}$ . A2 is sampled on SH<sub>2</sub> in a preceding conversion with Input Select 4<sub>H</sub>, 5<sub>H</sub>, or 6<sub>H</sub>. B2 is converted by ADC<sub>2</sub> on the signal  $\overline{\text{HOLD1}}$ . B2 is sampled on SH<sub>4</sub> in a preceding conversion with Input Select 4<sub>H</sub>, 5<sub>H</sub>, or 6<sub>H</sub>. AN2 is sampled by the synchronous sample-and-hold, SH<sub>5</sub>; ADC<sub>3</sub> converts it on the signal  $\overline{\text{HOLD1}}$ .

#### Input Select = 4<sub>H</sub>, 5<sub>H</sub> and 6<sub>H</sub>

A1 is sampled by the synchronous sample-and-hold, SH<sub>1</sub>; ADC<sub>1</sub> converts it on the signal  $\overline{\text{HOLD1}}$ . B1 is sampled by the synchronous sample-and-hold, SH<sub>3</sub>; ADC<sub>2</sub> converts it on the signal  $\overline{\text{HOLD1}}$ . AN1 is sampled by the synchronous sample-and-hold, SH<sub>5</sub>; ADC<sub>3</sub> converts it on the signal  $\overline{\text{HOLD1}}$ . A2 is sampled by the synchronous sample-and-hold, SH<sub>2</sub>, on the signal  $\overline{\text{HOLD1}}$ . B2 is sampled by the synchronous sample-and-hold, SH<sub>4</sub>, on the signal  $\overline{\text{HOLD1}}$ .

# Analog Motor Control Front-End with Simultaneous Sampling on Seven S/H Capacitors and Three 1MSPS, 12-Bit, 12-Channel ADCs ADS7869



SBAS253B – MAY 2003 – REVISED NOVEMBER 2004

## Input Select = 7<sub>H</sub>

IU is sampled by the synchronous sample-and-hold, SH<sub>1</sub>; ADC<sub>1</sub> converts it on the signal  $\overline{\text{HOLD1}}$ . IV is sampled by the synchronous sample-and-hold, SH<sub>3</sub>; ADC<sub>2</sub> converts it on the signal HOLD1. IW is sampled by the synchronous sample-and-hold, SH<sub>5</sub>; ADC<sub>3</sub> converts it on the signal HOLD1.

### 3.2.2 VECANA Timing Characteristics<sup>(1)</sup>

Over recommended operating free-air temperature range at -40°C to +85°C, AV<sub>DD</sub> = 5V, BV<sub>DD</sub> = 3V – 5V.

PARAMETER	SYMBOL	MIN	MAX	UNIT
ADCLK Period	t <sub>C1</sub>	62.5		ns
ADCLK HIGH or LOW Time	t <sub>w1</sub>	20		ns
HOLD1 Signal Setup Time	t <sub>SU1</sub>	25		ns
HOLD1 Signal Hold Time	t <sub>H1</sub>	20	15 + 12.5t <sub>C1</sub>	ns
HOLD2 Signal Setup Time	t <sub>SU2</sub>	0		ns
HOLD2 Signal Hold Time	t <sub>H2</sub>	0		ns
Delay Time from ADCLK Rising to DAV Falling Edge	t <sub>D1</sub>		15	ns
Output Data Delay Time	t <sub>D2</sub>		10	ns
Input Data Setup Time	t <sub>SU3</sub>	10		ns
Input Data Hold Time	t <sub>H3</sub>	10		ns
Delay Time from ADCLK Rising to DAV Rising Edge	t <sub>D3</sub>		15	ns
Sampling Time	t <sub>SAMPLE</sub>	4		t <sub>C1</sub>

(1) All input signals are specified with t<sub>R</sub> = t<sub>F</sub> = 5ns (10% to 90% of BV<sub>DD</sub>) and timed from a voltage level of (V<sub>IL</sub> + V<sub>IH</sub>)/2.

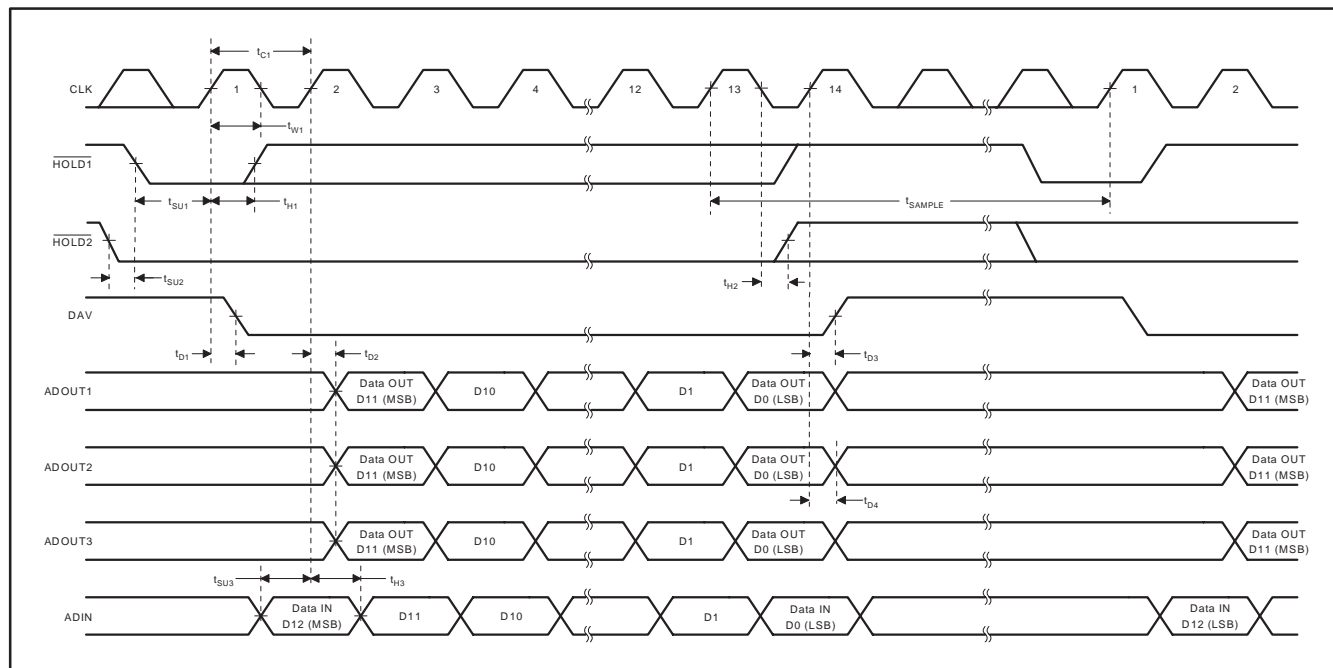

Figure 1–10. VECANA Access



### 3.2.3 WINCLK Selection

It is possible to apply a separate clock for the window comparators at the WINCLK (pin 51) in VECANA01 mode. By using the pins S0 (pin 52) and S1 (pin 53) as decoder inputs, the window comparators can be supplied with the system clock, an external clock (supplied by the WINCLK), and two divided external clocks; see Table 1–7.

**Table 1–7. Window Comparator Clock**

S1	S0	Clock to Window Comparators
0	0	Synchronous system clock
0	1	External WINCLK clock
1	0	External WINCLK clock / 2
1	1	External WINCLK clock / 4

The system clock, provided by CLK (pin 77), drives the window comparators in the other modes (SPI and parallel modes).

The window comparator clock, WINCLK, must be synchronous with the system clock, provided by CLK (pin 77). The window comparators can be supplied with a 6MHz clock when the system runs with a 15MHz clock.

In order to provide the window comparators with a maximum of 1µs detection time, a minimum clock of 6MHz must be supplied. See the *Window Comparator* section. It is necessary to operate the window comparators with a continuous clock.

### 3.3 Serial Peripheral Interface (SPI)

The SPI runs fully asynchronous to the rest of the system. The four signals of the SPI are SPICLK, SPISIMO, SPISOMI and SPISTE. The maximum speed of the SPI is 25MHz. When the select signal SPISTE is HIGH, the entire SPI, except the address and the data registers, is in reset state. The SPI clock SPICLK and the serial data input SPISIMO are disabled when SPISTE is HIGH. The incoming data is strobed by the SPI on the falling edge of the SPICLK. Outgoing data is put on the output SPISOMI on the rising edge of the SPICLK (see Figure 1–11). For a transmission of one 16-bit data word, 24 bits are required. The first incoming bit to the ADS7869 determines if the whole transmission is a read or a write operation. A '1' means a read and a '0' means a write operation. There are seven address bits, but only the six LSBs are used. Then the 16 data bits are transmitted or received (see Table 1–8).

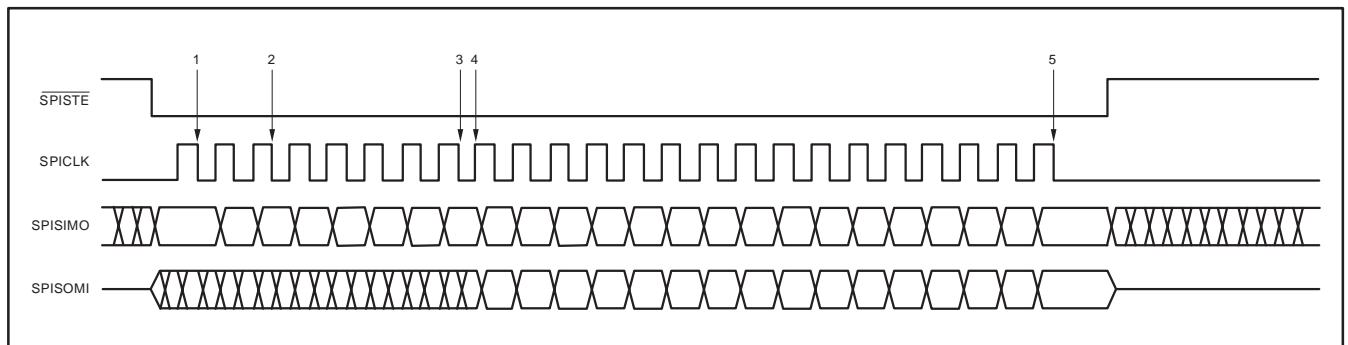

**Figure 1–11. One SPI Transfer Cycle.**

**Table 1–8. SPI Write 24-bit Word Format**

A23	A22	A21	A20	A19	A18	A17	A16	A15	A14	A13	A12	A11	A10	A9	A8	A7	A6	A5	A4	A3	A2	A1	A0
R/W	X	Address							Data														

# Analog Motor Control Front-End with Simultaneous Sampling on Seven S/H Capacitors and Three 1MSPS, 12-Bit, 12-Channel ADCs ADS7869

SBAS253B – MAY 2003 – REVISED NOVEMBER 2004

One 16-bit transfer is accomplished, as follows:

1. On the first falling edge of SPICLK, the read/write bit is strobed.
2. On the third falling edge of SPICLK, the MSB of the address (bit 5) is strobed.
3. On the eighth falling edge of SPICLK, the LSB of the address (bit 0) is strobed and the corresponding data of the register map is read.
4. On the ninth rising edge, the data read from the register map is latched into a shift register and shifted one position each rising edge of the SPICLK. This data is always sent out, even when a write operation is performed.
5. On the 24th falling edge of SPICLK, the last data bit is shifted in from SPISIMO and a write pulse is generated to write the data into the register map, if a write operation was performed.

During continuous read or write (see Figure 1–12), the address is decrementing after each read or write; see the indicating arrows. When the address is set to 00<sub>H</sub>, in the beginning, the FIFO can be read out fast. The data is written into the register map on the 16th SPICLK of a data word. If the  $\overline{\text{SPISTE}}$  is inactive before the 16th SPICLK in a data word, the data is not written into the register map; therefore, the data is lost.

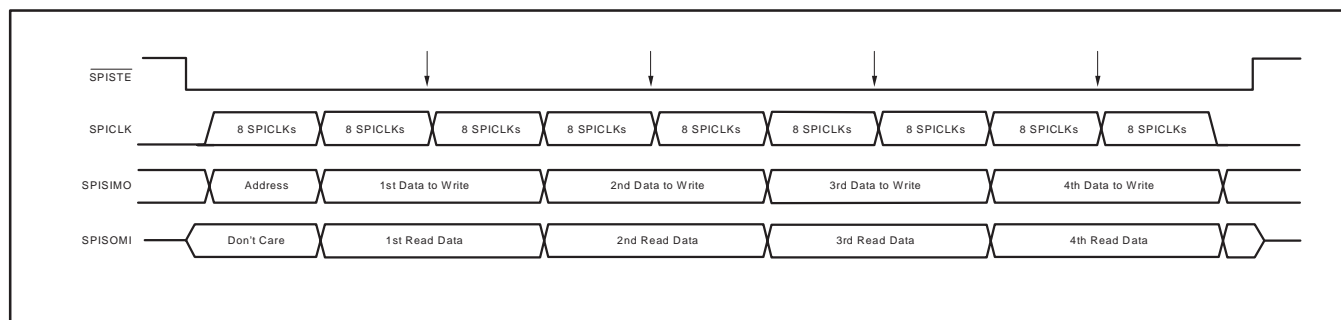

Figure 1–12. Continuous SPI Transfer Cycle

### 3.3.1 SPI Timing Characteristics(1)

Over recommended operating free-air temperature range at  $-40^{\circ}\text{C}$  to  $+85^{\circ}\text{C}$ ,  $\text{AV}_{\text{DD}} = 5\text{V}$ ,  $\text{BV}_{\text{DD}} = 3\text{V} - 5\text{V}$ .

PARAMETER	SYMBOL	MIN	MAX	UNIT
SPICLK Period	$t_{\text{C1}}$	40		ns
SPICLK HIGH or LOW Time	$t_{\text{W1}}$	10		ns
Delay Time from SPISTE Falling to SPICLK Rising Edge	$t_{\text{D1}}$	15		ns
Delay Time from SPISTE Falling to SPISOMI not Tristate	$t_{\text{D2}}$		15	ns
Data Setup Time	$t_{\text{SU1}}$	10		ns
Input Data Hold Time	$t_{\text{H1}}$	10		ns
Output Data Delay Time	$t_{\text{D3}}$		10	ns
Enable Lag Time	$t_{\text{D4}}$	15		ns
SPISOMI Disable Time	$t_{\text{D5}}$		15	ns
Sequential Transfer Delay	$t_{\text{W2}}$	30		ns

(1) All input signals are specified with  $t_{\text{R}} = t_{\text{F}} = 5\text{ns}$  (10% to 90% of  $\text{BV}_{\text{DD}}$ ) and timed from a voltage level of  $(V_{\text{IL}} + V_{\text{IH}})/2$ .

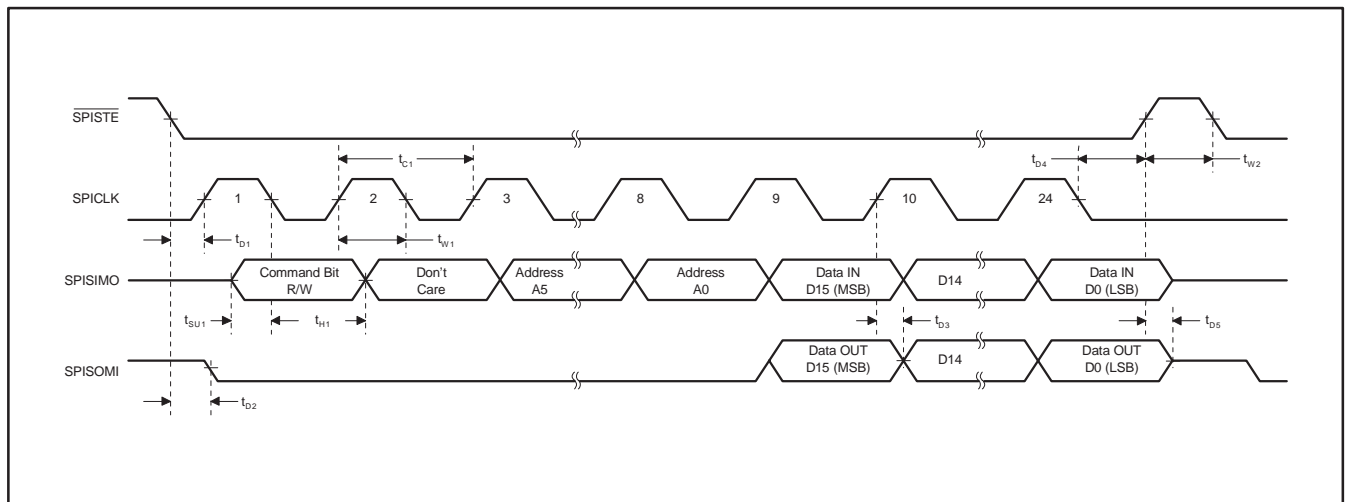

Figure 1–13. SPI Access

# Analog Motor Control Front-End with Simultaneous Sampling on Seven S/H Capacitors and Three 1MSPS, 12-Bit, 12-Channel ADCs ADS7869



SBAS253B – MAY 2003 – REVISED NOVEMBER 2004

## 3.4 Parallel Interface

The Parallel Interface has the following major capabilities:

1. Data words:
  - Data path with a width of 16 bits is supported.
2. Bus handshaking:
  - Separate  $\overline{RD}$  and  $\overline{WR}$  style control signals.
  - Separate  $R/\overline{W}$  and  $\overline{WE}$  style control signals.
3. Mapping
  - The ADS7869 appears as a memory-mapped peripheral. See Table 1–10 on page 37 and Table 1–11 on page 38.
  - Internal registers are directly mapped into consecutive locations in the external bus address space.

### 3.4.1 Parallel Read and Write Control

Reading from and writing to the ADS7869 is controlled by the chip select input ( $\overline{CS}$ , pin 57), the write input ( $\overline{WR}$ , pin 58) and the read input ( $\overline{RD}$ , pin 59). There is a control bit for mode 11, which can be reset to activate a special compatibility mode. (See *Mode 11 Bus Access [DSP-compatible mode]* section.) The read and write pins can be configured as a combined Read/Write and Write enable depending on the needs of the host processor. The mode pins M0 and M1 determine the method by which the ADS7869 is accessed by the host (see Table 1–9).

**Table 1–9. Host Parallel Port Operation**

[M1, M0]	PIN NAME	PIN NO.	FUNCTION	OPERATION
,10'	$R/\overline{W}$	59	Read/Write Signal	0: Data can be written to ADS7869; see $\overline{WE}$ 1: Data from ADS7869 is written to the Data Bus
	$\overline{WE}$	58	Write Enable	0: Data Bus is read by ADS7869 at rising edge 1: ADS7869 Write function is disabled
,11' standard	$\overline{RD}$	59	Read Signal	0: Data from ADS7869 is written to the Data Bus 1: ADS7869 Read function is disabled
	$\overline{WR}$	58	Write Signal	0: Data Bus is read by ADS7869 at rising edge 1: ADS7869 Write function is disabled
,11'TMS	—	59	—	Signal is ignored by ADS7869
	$R/\overline{W}$	58	Read/Write Signal	0: Data Bus is read by ADS7869 at rising edge of $\overline{CS}$ 1: Data from ADS7869 is written to the Data Bus

### 3.4.2 Mode 10 Bus Access

When M1 = 1 and M0 = 0 (mode 10), the host port uses the  $\overline{RD}$  (pin 59) as a read/write signal ( $R/\overline{W}$ ) and the  $\overline{WR}$  (pin 58) as a write-enable signal  $\overline{WE}$ . The current cycle is only processed when the chip select input  $\overline{CS}$  (pin 57) of the ADS7869 is active low.

$R/\overline{W}$  determines the direction of the transfer during a bus cycle; see Figure 1–14. When  $R/\overline{W}$  is high, data is placed on the databus by ADS7869, according to the address, as long as  $\overline{CS}$  is low.

For a write cycle, a low-level signal (on  $\overline{WE}$ ) indicates to the ADS7869 that the data on the bus is valid. With the rising edge of  $\overline{WE}$  the data is latched into the ADS7869. When the host sets  $\overline{CS}$  to low, a valid access to the ADS7869 is detected (see Figure 1–15).

#### 3.4.2.1 Read Timing Characteristics<sup>(1)</sup>

Over recommended operating free-air temperature range at  $-40^{\circ}\text{C}$  to  $+85^{\circ}\text{C}$ ,  $AV_{DD} = 5\text{V}$ ,  $BV_{DD} = 3\text{V} - 5\text{V}$ .

PARAMETER	SYMBOL	MIN	MAX	UNIT
Delay time from CS LOW to output data not in tri-state mode <sup>(2)</sup>	$t_{D1}$		8	ns
Access time from address valid to output data valid	$t_{A1}$		10	ns
Delay time from address not valid to output data not valid <sup>(3)</sup>	$t_{D2}$	0	8	ns
Delay time from CS HIGH to output data in tri-state mode <sup>(4)</sup>	$t_{D3}$		8	ns

- (1) All input signals are specified with  $t_R = t_F = 5\text{ns}$  (10% to 90% of  $BV_{DD}$ ) and timed from a voltage level of  $(V_{IL} + V_{IH})/2$ .
- (2) Refer to  $\overline{CS}$  signal or  $R/\overline{W}$  signal whichever occurs last.
- (3) One or more read cycles can be performed in one  $\overline{CS}$  cycle.
- (4) Refer to  $\overline{CS}$  signal or  $R/\overline{W}$  signal whichever occurs first.

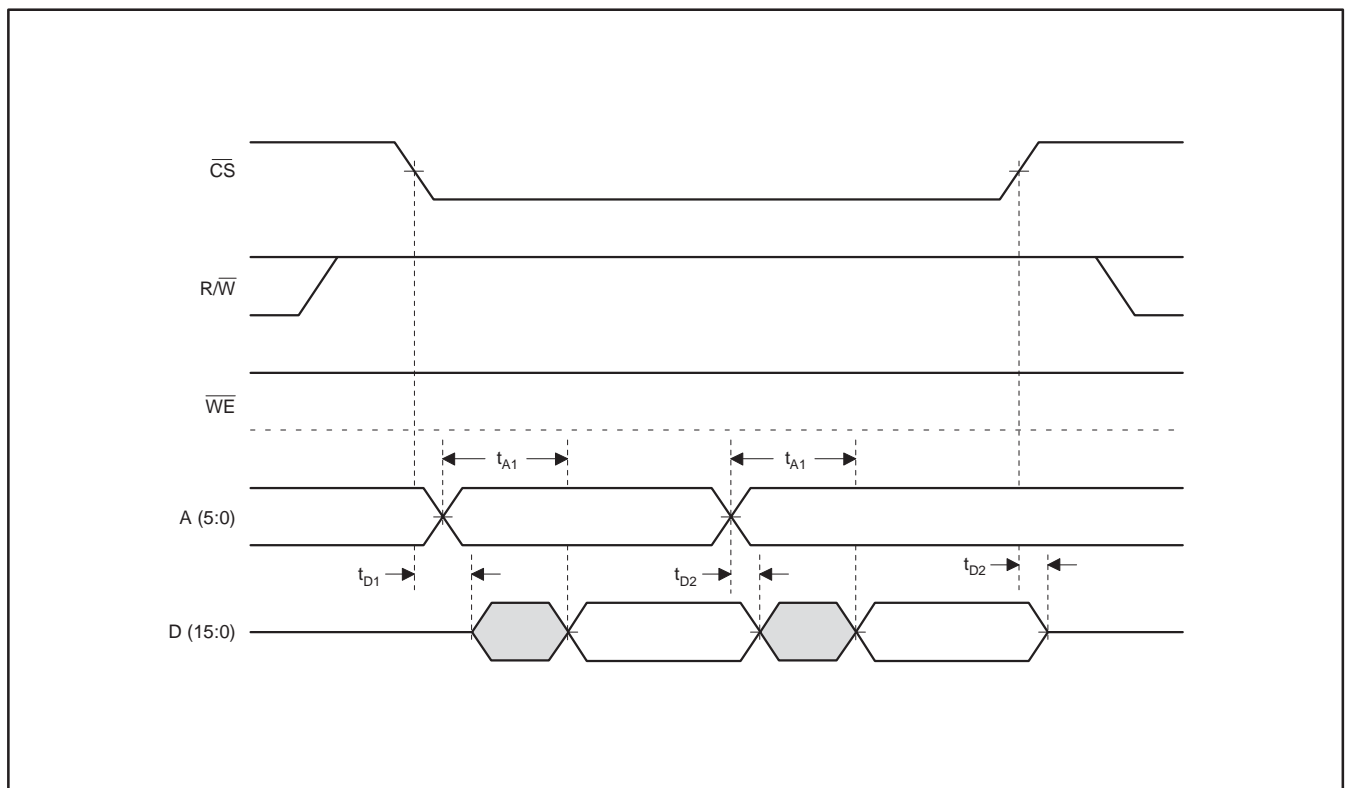

Figure 1–14. Mode 10 Read Access

# Analog Motor Control Front-End with Simultaneous Sampling on Seven S/H Capacitors and Three 1MSPS, 12-Bit, 12-Channel ADCs ADS7869

SBAS253B – MAY 2003 – REVISED NOVEMBER 2004

## 3.4.2.2 Write Timing Characteristics(1)

Over recommended operating free-air temperature range at  $-40^{\circ}\text{C}$  to  $+85^{\circ}\text{C}$ ,  $\text{AV}_{\text{DD}} = 5\text{V}$ ,  $\text{BV}_{\text{DD}} = 3\text{V} - 5\text{V}$ .

PARAMETER	SYMBOL	MIN	MAX	UNIT
Delay time from R/W LOW to CS LOW	$t_{\text{D1}}$	0		ns
Access time from CS LOW to WE HIGH	$t_{\text{A1}}$	25		ns
Width time for WE LOW	$t_{\text{W1}}$	20		ns
Width time for WE HIGH(2)	$t_{\text{W2}}$	10		ns
Setup time, address valid before rising edge of WE	$t_{\text{SU1}}$	10		ns
Hold time, address valid after rising edge of WE	$t_{\text{H1}}$	5		ns
Setup time, data valid before rising edge of WE	$t_{\text{SU2}}$	10		ns
Hold time, data valid after rising edge of WE	$t_{\text{H2}}$	5		ns
Delay time from WE HIGH to CS HIGH	$t_{\text{D2}}$	10		ns
Delay time from CS HIGH to R/W HIGH	$t_{\text{D3}}$	0		ns

(1) All input signals are specified with  $t_{\text{R}} = t_{\text{F}} = 5\text{ns}$  (10% to 90% of  $\text{BV}_{\text{DD}}$ ) and timed from a voltage level of  $(V_{\text{IL}} + V_{\text{IH}})/2$ .

(2) One or more write cycles can be performed in one CS cycle.

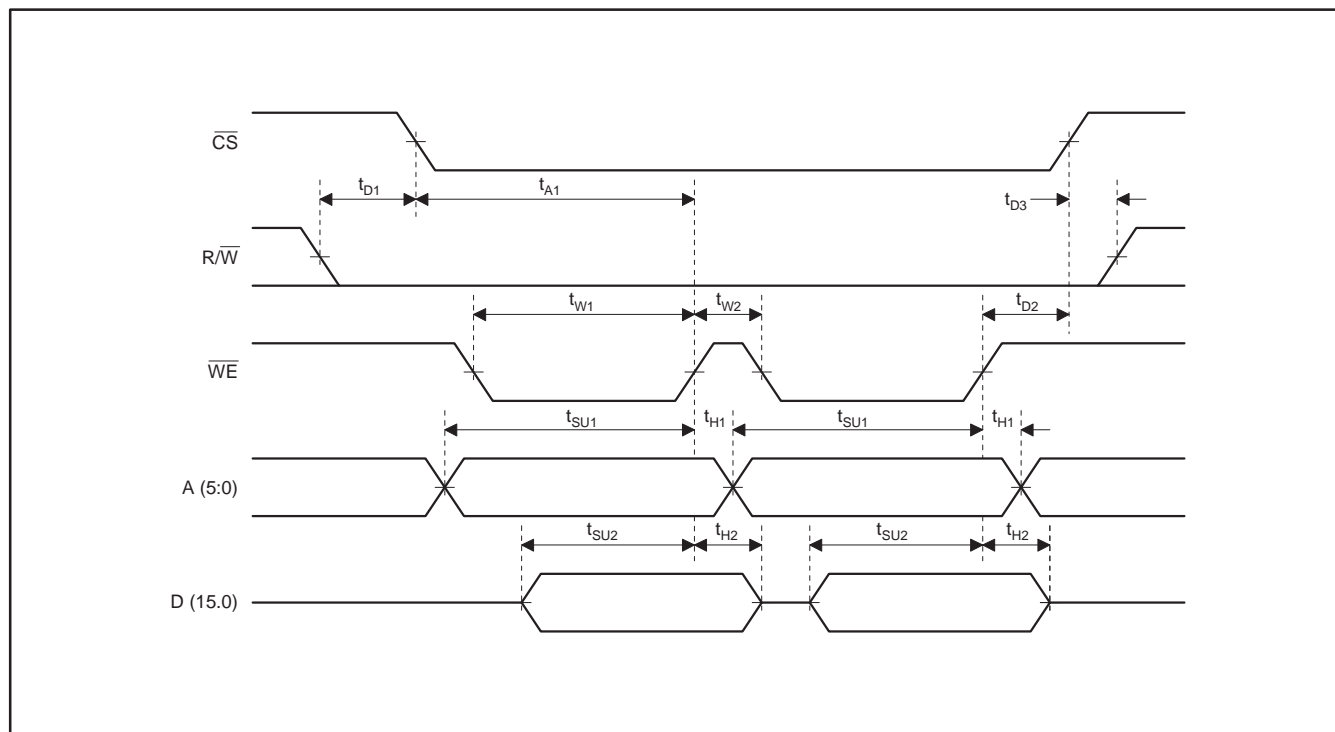

Figure 1–15. Mode 10 Write Access

### 3.4.3 Mode 11 Bus Access (Standard Mode)

When M1 = 1 and M0 = 1 (mode 11), the host port uses  $\overline{WR}$  (pin 58) and  $\overline{RD}$  (pin 59) for independent write and read access to the ADS7869. The current cycle is processed only when the  $\overline{CS}$  (pin 57) input of the ADS7869 is an active low. Bit 0 of the PARALLEL register (Address 27<sub>H</sub>) must have a reset value of 1 to use the standard mode.

In Mode 11 operation,  $\overline{RD}$  indicates to the ADS7869 that the host processor has requested a data transfer (see Figure 1–16). The ADS7869 outputs data to the host. The address can be changed within a  $\overline{CS}$  low cycle, and more than one data can be read.

To configure the registers in the ADS7869, the host issues a  $\overline{WR}$  signal to indicate that valid data is available on the bus. With the rising edge of the  $\overline{WR}$  the data is latched into the ADS7869; see Figure 1–17. The address for the ADS7869 must be valid before the write operation takes place. The  $\overline{CS}$  signal can stay low between two consecutive writes.

#### 3.4.3.1 Read Timing Characteristics<sup>(1)</sup>

Over recommended operating free-air temperature range at –40°C to +85°C, AV<sub>DD</sub> = 5V, BV<sub>DD</sub> = 3V – 5V.

PARAMETER	SYMBOL	MIN	MAX	UNIT
Delay time from CS LOW to output data not in tri-state mode <sup>(2)</sup>	t <sub>D1</sub>		8	ns
Access time from address valid to output data valid	t <sub>A1</sub>		10	ns
Delay time from address not valid to output data not valid <sup>(3)</sup>	t <sub>D2</sub>	0	8	ns
Delay time from CS HIGH to output data in tri-state mode <sup>(4)</sup>	t <sub>D3</sub>		8	ns

- (1) All input signals are specified with t<sub>R</sub> = t<sub>F</sub> = 5ns (10% to 90% of BV<sub>DD</sub>) and timed from a voltage level of (V<sub>IL</sub> + V<sub>IH</sub>)/2.
- (2) Refer to  $\overline{CS}$  signal or  $\overline{RD}$  signal whichever occurs last.
- (3) One or more read cycles can be performed in one  $\overline{CS}$  cycle.
- (4) Refer to  $\overline{CS}$  signal or  $\overline{RD}$  signal whichever occurs first.

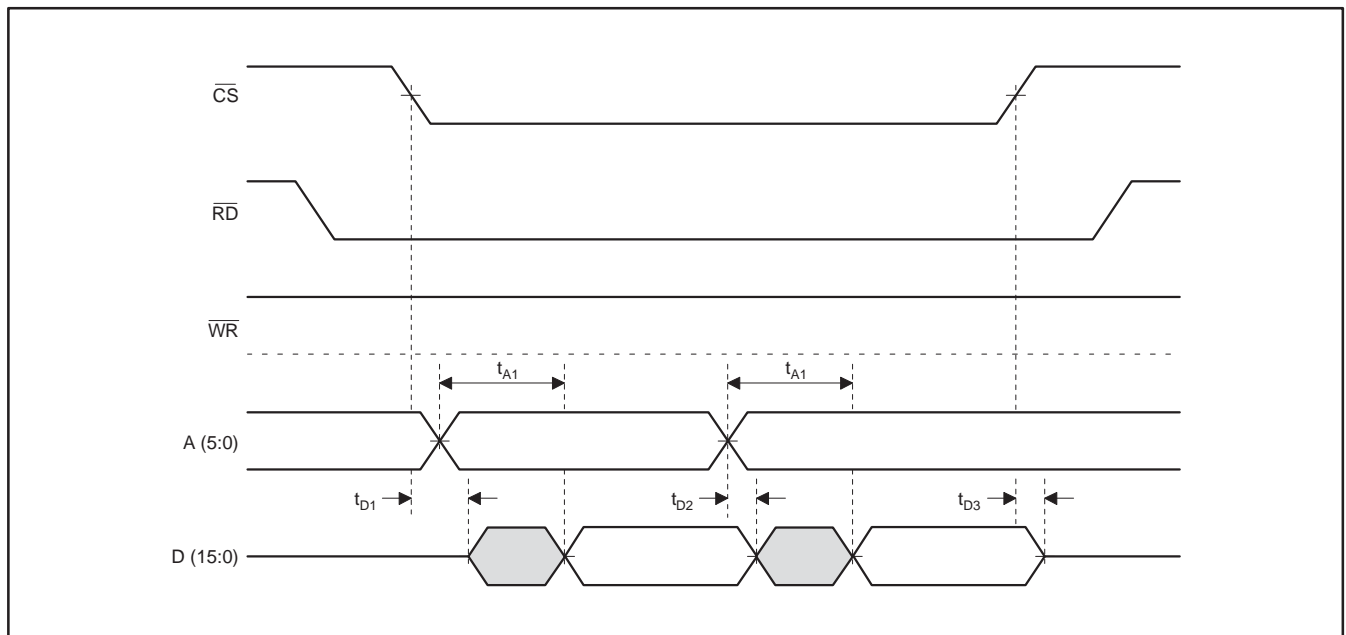

**Figure 1–16. Mode 11 Read Access (Standard Mode)**

# Analog Motor Control Front-End with Simultaneous Sampling on Seven S/H Capacitors and Three 1MSPS, 12-Bit, 12-Channel ADCs ADS7869

SBAS253B – MAY 2003 – REVISED NOVEMBER 2004

## 3.4.3.2 Write Timing Characteristics(1)

Over recommended operating free-air temperature range at  $-40^{\circ}\text{C}$  to  $+85^{\circ}\text{C}$ ,  $\text{AV}_{\text{DD}} = 5\text{V}$ ,  $\text{BV}_{\text{DD}} = 3\text{V} - 5\text{V}$ .

PARAMETER	SYMBOL	MIN	MAX	UNIT
Access time from CS LOW to WR HIGH	$t_{A1}$	15		ns
Width time for WR LOW	$t_{W1}$	10		ns
Width time for WR HIGH <sup>(2)</sup>	$t_{W2}$	10		ns
Setup time, address valid before rising edge of WR	$t_{SU1}$	10		ns
Hold time, address valid after rising edge of WR	$t_{H1}$	5		ns
Setup time, data valid before rising edge of WR	$t_{SU2}$	10		ns
Hold time, data valid after rising edge of WR	$t_{H2}$	5		ns
Delay time from WR HIGH to CS HIGH	$t_{D1}$	10		ns

- (1) All input signals are specified with  $t_R = t_F = 5\text{ns}$  (10% to 90% of  $\text{BV}_{\text{DD}}$ ) and timed from a voltage level of  $(V_{\text{IL}} + V_{\text{IH}})/2$ .  
 (2) One or more write cycles can be performed in one CS cycle.

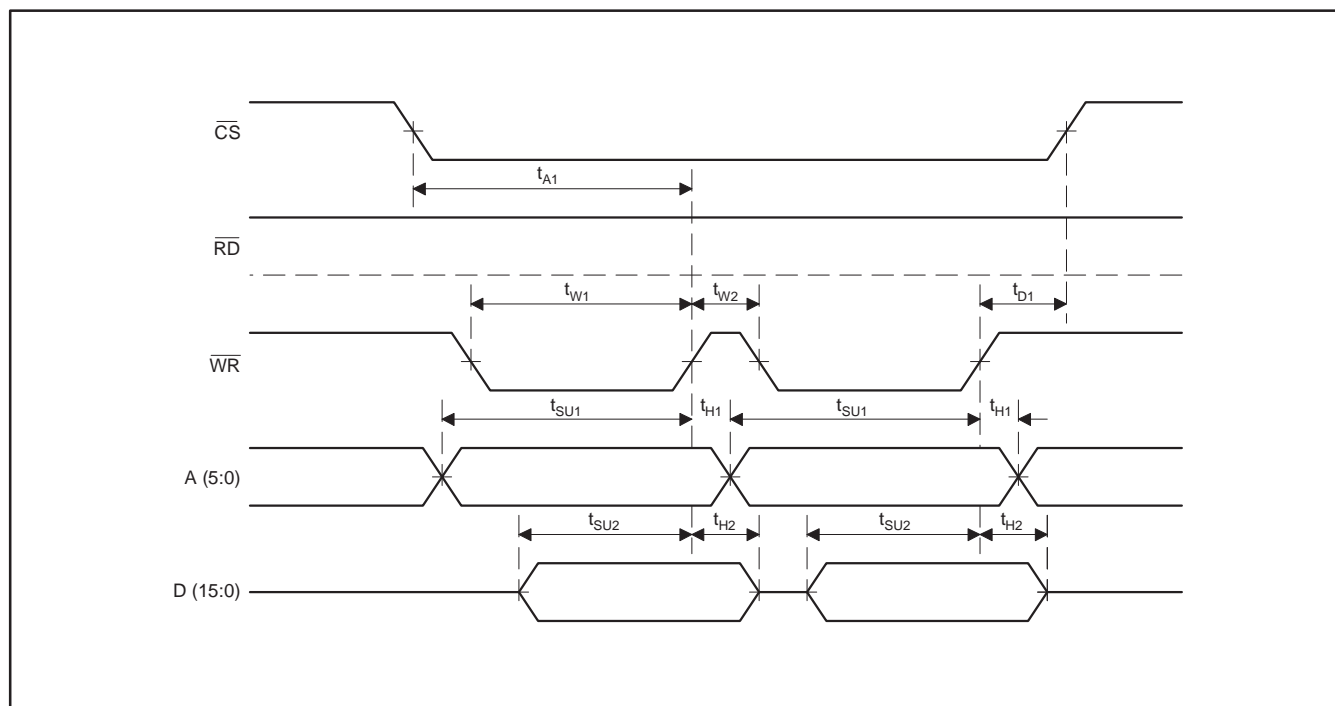

Figure 1–17. Mode 11 Write Access (Standard Mode)



### 3.4.4 Mode 11 Bus Access (TMS320c54xx DSP Family-Compatible Mode)

In the TMS320c54xx DSP family-compatible mode ( $M1 = 1$  and  $M0 = 1$ ), the host port uses  $\overline{CS}$  (pin 57) together with  $\overline{WR}$  (pin 57) as an  $R/\overline{W}$  for independent read and write access to the ADS7869. Bit 0 of the PARALLEL register (address  $27_H$ ) must have a value of 0 to use this compatible mode.

In this mode,  $\overline{CS}$ , together with the  $R/\overline{W}$  (which remains high), indicates to the ADS7869 that the host processor has requested a read data transfer (see Figure 1–18). The ADS7869 will output data to the host as long as the  $\overline{CS}$  is an active low.

To configure the registers, in the ADS7869 the host puts the  $R/\overline{W}$  signal to low to indicate that valid data is available on the bus. With the rising edge of the  $\overline{CS}$ , the data is latched into the ADS7869 (see Figure 1–19). The address for the ADS7869 must be valid before the  $\overline{CS}$  is set to low.

Before using this mode, the register bit 0 at address  $27_H$  must be reset. The reset can be performed with a TMS320C54xx DSP write operation with the original mode 11, because the write access is similar to the write access of mode 11. (See *Mode 11 Bus Access [standard mode]* section.) This mode can perform read operations, after bit 0 is reset, as mentioned above.

#### 3.4.4.1 Read Timing Characteristics<sup>(1)</sup>

Over recommended operating free-air temperature range at  $-40^\circ\text{C}$  to  $+85^\circ\text{C}$ ,  $AV_{DD} = 5\text{V}$ ,  $BV_{DD} = 3\text{V} - 5\text{V}$ .

PARAMETER	SYMBOL	MIN	MAX	UNIT
Delay time from CS LOW to output data not in tri-state mode	$t_{D1}$		8	ns
Access time from address valid to output data valid	$t_{A1}$		10	ns
Delay time from address not valid to output data not valid <sup>(2)</sup>	$t_{D2}$	0	8	ns
Delay time from CS HIGH to output data in tri-state mode	$t_{D3}$		8	ns

(1) All input signals are specified with  $t_R = t_F = 5\text{ns}$  (10% to 90% of  $BV_{DD}$ ) and timed from a voltage level of  $(V_{IL} + V_{IH})/2$ .

(2) One or more read cycles can be performed in one  $\overline{CS}$  cycle.

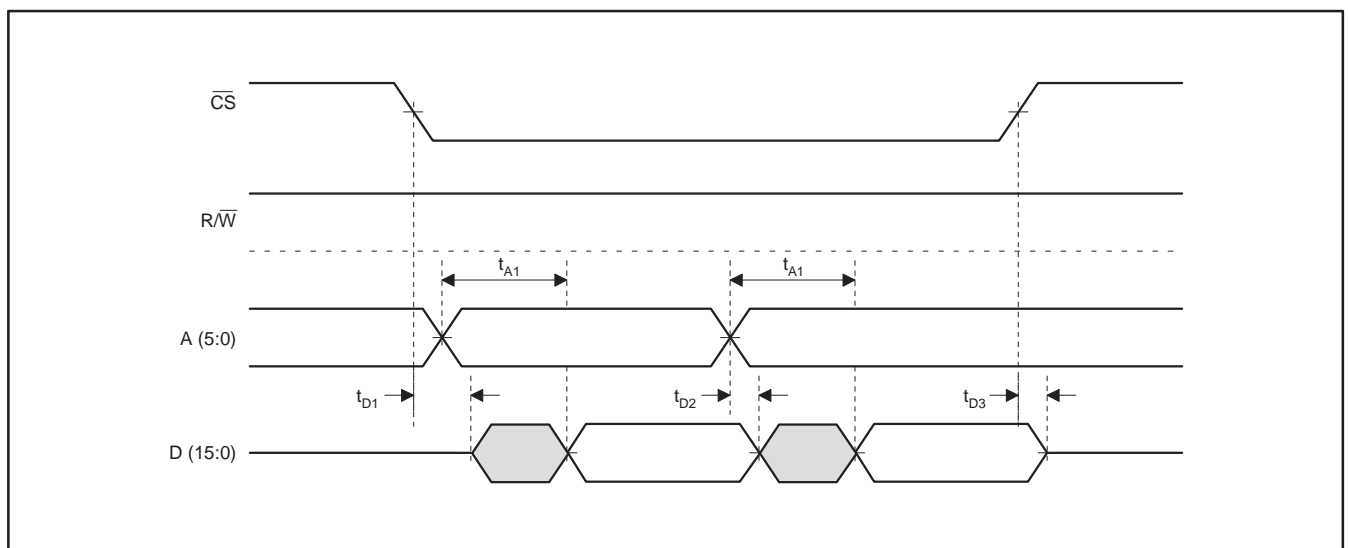

Figure 1–18. Mode 11 Read Access (TMS320c54xx mode)

# Analog Motor Control Front-End with Simultaneous Sampling on Seven S/H Capacitors and Three 1MSPS, 12-Bit, 12-Channel ADCs ADS7869



SBAS253B – MAY 2003 – REVISED NOVEMBER 2004

## 3.4.4.2 Write Timing Characteristics(1)

Over recommended operating free-air temperature range at  $-40^{\circ}\text{C}$  to  $+85^{\circ}\text{C}$ ,  $\text{AV}_{\text{DD}} = 5\text{V}$ ,  $\text{BV}_{\text{DD}} = 3\text{V} - 5\text{V}$ .

PARAMETER	SYMBOL	MIN	MAX	UNIT
Setup time from R/W LOW to CS LOW	$t_{\text{SU1}}$	0		ns
Hold time from CS HIGH to R/W HIGH	$t_{\text{H1}}$	5		ns
Setup time from address valid to CS LOW	$t_{\text{SU2}}$	10		ns
Hold time from CS HIGH to address not valid	$t_{\text{H2}}$	5		ns
Setup time from data valid to CS HIGH	$t_{\text{SU3}}$	10		ns
Hold time from CS HIGH to data not valid	$t_{\text{H3}}$	5		ns

(1) All input signals are specified with  $t_{\text{R}} = t_{\text{F}} = 5\text{ns}$  (10% to 90% of  $\text{BV}_{\text{DD}}$ ) and timed from a voltage level of  $(V_{\text{IL}} + V_{\text{IH}})/2$ .

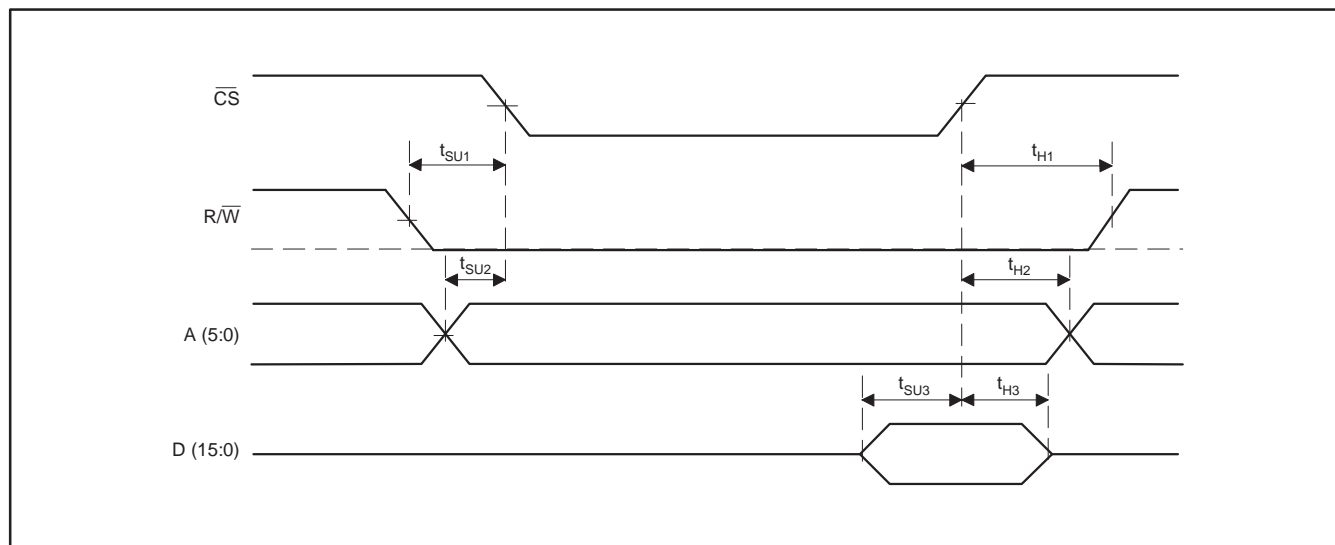

Figure 1–19. Mode 11 Write Access (TMS320c54xx mode)

### 3.5 Register Map

**Table 1–10. Register Map Write 16-bit Data**

ADDRESS	D15	D14	D13	D12	D11	D10	D9	D8	D7	D6	D5	D4	D3	D2	D1	D0	
00 <sub>H</sub>	Unwriteable (don't care)																
01 <sub>H</sub>	x	x	x	x	x	x	Channel IU, write 10-bit offset DAC-value										
02 <sub>H</sub>	x	x	x	x	x	x	Channel A1, write 10-bit offset DAC-value										
03 <sub>H</sub>	x	x	x	x	x	x	Channel A2, write 10-bit offset DAC-value										
04 <sub>H</sub>	x	x	x	x	x	x	Channel IV, write 10-bit offset DAC-value										
05 <sub>H</sub>	x	x	x	x	x	x	Channel B1, write 10-bit offset DAC-value										
06 <sub>H</sub>	x	x	x	x	x	x	Channel B2, write 10-bit offset DAC-value										
07 <sub>H</sub>	x	x	x	x	x	x	Channel IW, write 10-bit offset DAC-value										
08 <sub>H</sub>	x	x	x	x	x	x	Channel AN1, write 10-bit offset DAC-value										
09 <sub>H</sub>	x	x	x	x	x	x	Channel AN2, write 10-bit offset DAC-value										
0A <sub>H</sub>	x	x	x	x	x	x	Channel AN3, write 10-bit offset DAC-value										
0B <sub>H</sub>	x	x	x	x	x	x	Channel AX, write 10-bit offset DAC-value										
0C <sub>H</sub>	x	x	x	x	x	x	Channel BX, write 10-bit offset DAC-value										
0D <sub>H</sub>	x	x	x	x	Channel IU, write 12-bit gain DAC-value												
0E <sub>H</sub>	x	x	x	x	Channel A1, write 12-bit gain DAC-value												
0F <sub>H</sub>	x	x	x	x	Channel A2, write 12-bit gain DAC-value												
10 <sub>H</sub>	x	x	x	x	Channel IV, write 12-bit gain DAC-value												
11 <sub>H</sub>	x	x	x	x	Channel B1, write 12-bit gain DAC-value												
12 <sub>H</sub>	x	x	x	x	Channel B2, write 12-bit gain DAC-value												
13 <sub>H</sub>	x	x	x	x	Channel IW, write 12-bit gain DAC-value												
14 <sub>H</sub>	x	x	x	x	Channel AN1, write 12-bit gain DAC-value												
15 <sub>H</sub>	x	x	x	x	Channel AN2, write 12-bit gain DAC-value												
16 <sub>H</sub>	x	x	x	x	Channel AN3, write 12-bit gain DAC-value												
17 <sub>H</sub>	x	x	x	x	Channel AX, write 12-bit gain DAC-value												
18 <sub>H</sub>	x	x	x	x	Channel BX, write 12-bit gain DAC-value												
19 <sub>H</sub>	x	x	x	x	x	x	x	x	Over current, write 8-bit window DAC-value								
1A <sub>H</sub>	x	x	x	x	x	x	x	x	x	x	x	DAV	x	INPUT			
1B <sub>H</sub>	x	x	x	x	x	x	x	x	x	x	x	x	Write 4-bit counter control				
1C <sub>H</sub>	Unwriteable (don't care)																
1D <sub>H</sub>	Counter 1, write 16-bit value in EDGECOUNT1 counter																
1E <sub>H</sub>	Unwriteable (don't care)																
1F <sub>H</sub>	Unwriteable (don't care)																
20 <sub>H</sub>	Unwriteable (don't care)																
21 <sub>H</sub>	Counter 2, write 16-bit value in EDGECOUNT2 counter																
22 <sub>H</sub>	Unwriteable (don't care)																
23 <sub>H</sub>	Unwriteable (don't care)																
24 <sub>H</sub>	write 16-bit value in FIFO_TEST register																
25 <sub>H</sub>	write 16-bit value in COMP_TEST register																
26 <sub>H</sub>	Counter interrupt enables				x	x	x	x	x	x	x	x	x	x	x	FIFO interrupt enables	
27 <sub>H</sub>	x	x	x	x	x	x	x	x	x	x	x	x	x	x	x	PARALLEL	
28 <sub>H</sub>	write 16-bit value in RESET register																
29 <sub>H</sub> –3F <sub>H</sub>	Unwriteable (don't care)																

NOTE: 'x' means unwriteable (don't care)

# Analog Motor Control Front-End with Simultaneous Sampling on Seven S/H Capacitors and Three 1MSPS, 12-Bit, 12-Channel ADCs ADS7869



SBAS253B – MAY 2003 – REVISED NOVEMBER 2004

**Table 1–11. Register Map Read 16-bit Data**

ADDRESS	D15	D14	D13	D12	D11	D10	D9	D8	D7	D6	D5	D4	D3	D2	D1	D0	
00 <sub>H</sub>	FIFO data																
01 <sub>H</sub>	Channel IU, read 10-bit offset DAC-value <sup>(1)</sup>																
02 <sub>H</sub>	Channel A1, read 10-bit offset DAC-value <sup>(1)</sup>																
03 <sub>H</sub>	Channel A2, read 10-bit offset DAC-value <sup>(1)</sup>																
04 <sub>H</sub>	Channel IV, read 10-bit offset DAC-value <sup>(1)</sup>																
05 <sub>H</sub>	Channel B1, read 10-bit offset DAC-value <sup>(1)</sup>																
06 <sub>H</sub>	Channel B2, read 10-bit offset DAC-value <sup>(1)</sup>																
07 <sub>H</sub>	Channel IW, read 10-bit offset DAC-value <sup>(1)</sup>																
08 <sub>H</sub>	Channel AN1, read 10-bit offset DAC-value <sup>(1)</sup>																
09 <sub>H</sub>	Channel AN2, read 10-bit offset DAC-value <sup>(1)</sup>																
0A <sub>H</sub>	Channel AN3, read 10-bit offset DAC-value <sup>(1)</sup>																
0B <sub>H</sub>	Channel AX, read 10-bit offset DAC-value <sup>(1)</sup>																
0C <sub>H</sub>	Channel BX, read 10-bit offset DAC-value <sup>(1)</sup>																
0D <sub>H</sub>	0	0	0	0	Channel IU, read 12-bit gain DAC-value												
0E <sub>H</sub>	0	0	0	0	Channel A1, read 12-bit gain DAC-value												
0F <sub>H</sub>	0	0	0	0	Channel A2, read 12-bit gain DAC-value												
10 <sub>H</sub>	0	0	0	0	Channel IV, read 12-bit gain DAC-value												
11 <sub>H</sub>	0	0	0	0	Channel B1, read 12-bit gain DAC-value												
12 <sub>H</sub>	0	0	0	0	Channel B2, read 12-bit gain DAC-value												
13 <sub>H</sub>	0	0	0	0	Channel IW, read 12-bit gain DAC-value												
14 <sub>H</sub>	0	0	0	0	Channel AN1, read 12-bit gain DAC-value												
15 <sub>H</sub>	0	0	0	0	Channel AN2, read 12-bit gain DAC-value												
16 <sub>H</sub>	0	0	0	0	Channel AN3, read 12-bit gain DAC-value												
17 <sub>H</sub>	0	0	0	0	Channel AX, read 12-bit gain DAC-value												
18 <sub>H</sub>	0	0	0	0	Channel BX, read 12-bit gain DAC-value												
19 <sub>H</sub>	(3)	(3)	(3)	(3)	(3)	(3)	(3)	(3)	Over current, read 8-bit window DAC-value								
1A <sub>H</sub>	0	0	0	0	0	0	0	0	0	0	0	DAV	0	INPUT			
1B <sub>H</sub>	Read counter control and status register																
1C <sub>H</sub>	Counter 1, read 16-bit value in ASEDGCNT1 register																
1D <sub>H</sub>	Counter 1, read 16-bit value in SYEDGCNT1 register																
1E <sub>H</sub>	Counter 1, read 16-bit value in SYEDGPRD1 register																
1F <sub>H</sub>	Counter 1, read 16-bit value in SYEDGTIME1 register																
20 <sub>H</sub>	Counter 2, read 16-bit value in ASEDGCNT2 register																
21 <sub>H</sub>	Counter 2, read 16-bit value in SYEDGCNT2 register																
22 <sub>H</sub>	Counter 2, read 16-bit value in SYEDGPRD2 register																
23 <sub>H</sub>	Counter 2, read 16-bit value in SYEDGTIME2 register																
24 <sub>H</sub>	Read 16-bit value in FIFO_TEST register																
25 <sub>H</sub> <sup>(2)</sup>	Read 6 MSB of COMP register							B2	B1	A2	A1	UC	VC	WC	UI	VI	WI
26 <sub>H</sub>	Read INTERRUPT register																
27 <sub>H</sub>	0	0	0	0	0	0	0	0	0	0	0	0	0	0	0	PARALLEL	
28 <sub>H</sub>	Read 0000 <sub>H</sub>																
29 <sub>H</sub> –3F <sub>H</sub>	Unused (read 0000 <sub>H</sub> )																

(1) MSB is copied to upper bits to achieve 16-bit two's complement values.

(2) The lower 10 bits are the comparator outputs.

(3) The MSB of the 8-bit DAC is copied in the upper 8 bits.

### 3.6 Register Descriptions

The following table shows the symbols that are used in this section. The last number in the symbol represents the reset value.

R	Readable Bit
W	Writeable Bit
U	Unused
0/1	Value After Reset

#### 3.6.1 FIFO Data Register (00<sub>H</sub>)

The FIFO Data Register is at address 00<sub>H</sub> in the register map. The output word of the FIFO is in 16-bit format. The resolution of the ADCs is 12 bits. Output data from each of the ADCs is in binary two's complement format. The four MSBs are used for channel identification. The format of the output word is shown in Table 1–12.

There are three words stored in the FIFO for each conversion. There must be three read accesses to this register to get all three conversion values out of the FIFO.

**Table 1–12. FIFO Output Word Format**

R0	R0	R0	R0	R0	R0	R0	R0	R0	R0	R0	R0	R0	R0	R0	R0
CA3	CA2	CA1	CA0	D11	D10	D9	D8	D7	D6	D5	D4	D3	D2	D1	D0
bit 15	bit 14	bit 13	bit 12	bit 11	bit 10	bit 9	bit 8	bit 7	bit 6	bit 5	bit 4	bit 3	bit 2	bit 1	bit 0

CA3–0: INPUT CHANNEL ADDRESS BITS	
<b>Bit 15–12:</b>	0000 = Data from IU input 0001 = Data from A1 input 0010 = Data from A2 input 0011 = Data from IV input 0100 = Data from B1 input 0101 = Data from B2 input 0110 = Data from IW input 0111 = Data from AN1 input 1000 = Data from AN2 input 1001 = Data from AN3 input 1010 = Data from AX input 1011 = Data from BX input 1100 = Unused 1101 = Unused 1110 = Unused 1111 = Unused
<b>Bit 11–0:</b>	<b>DATA11–0:</b> The output from the ADCs

In test mode, the upper four bits are copied from Bit 11 of the written data; see the *FIFO Test Register (24<sub>H</sub>)* section.

# Analog Motor Control Front-End with Simultaneous Sampling on Seven S/H Capacitors and Three 1MSPS, 12-Bit, 12-Channel ADCs ADS7869



SBAS253B – MAY 2003 – REVISED NOVEMBER 2004

## 3.6.2 Offset Registers (01<sub>H</sub> – 0C<sub>H</sub>)

The Offset Registers are stored at the addresses 01<sub>H</sub> to 0C<sub>H</sub>. The Offset Registers are 10 bits wide and represented in the two's complement format. The sign bit is copied in bit locations 15 to 10. This copy is only performed by a read access (that is, bits 15 to 10 must not be correctly set, in order to achieve the copy of the sign bit). The data format is shown in Table 1–13. The valid offset adjustment values are from –511 (201<sub>H</sub>) to +511 (1FF<sub>H</sub>). The value –512 (200<sub>H</sub>) is not allowed.

**Table 1–13. Offset Registers**

R0	R0	R0	R0	R0	R0	RW0	RW0	RW0	RW0	RW0	RW0	RW0	RW0	RW0	RW0
D9	D9	D9	D9	D9	D9	D9	D8	D7	D6	D5	D4	D3	D2	D1	D0
bit 15	bit 14	bit 13	bit 12	bit 11	bit 10	bit 9	bit 8	bit 7	bit 6	bit 5	bit 4	bit 3	bit 2	bit 1	bit 0
<b>Bit 15–9:</b>						D9: The MSB of the offset									
<b>Bit 8–0:</b>						D9–0: The 10 bits of the offset value									

## 3.6.3 Gain Registers (0D<sub>H</sub> to 18<sub>H</sub>)

The Gain Registers are stored at the addresses 0D<sub>H</sub> to 18<sub>H</sub>. The Gain Registers are 12 bits wide. The gain value is stored in a straight binary format. The data format is shown in Table 1–14.

**Table 1–14. Gain Registers**

R0	R0	R0	R0	RW0	RW0	RW0	RW0	RW0	RW0	RW0	RW0	RW0	RW0	RW0	RW0
0	0	0	0	D11	D10	D9	D8	D7	D6	D5	D4	D3	D2	D1	D0
bit 15	bit 14	bit 13	bit 12	bit 11	bit 10	bit 9	bit 8	bit 7	bit 6	bit 5	bit 4	bit 3	bit 2	bit 1	bit 0
<b>Bit 15–12:</b>				Always read as '0'; don't care at write											
<b>Bit 11–0:</b>				D11–0: The 12 bits of the gain value											

## 3.6.4 WINDAC Register (19<sub>H</sub>)

The WINDAC Register is located in address 19<sub>H</sub>. The WINDAC Register sets the output of the 8-bit DAC used by the window comparators. The word is in 8-bit straight binary format. The output voltage is a function of the register value and the internal reference voltage. (See Table 1–3.) The format of the data word is shown in Table 1–15.

**Table 1–15. WINDAC Register**

R0	R0	R0	R0	R0	R0	R0	R0	RW0	RW0	RW0	RW0	RW0	RW0	RW0	RW0
D7	D7	D7	D7	D7	D7	D7	D7	D7	D6	D5	D4	D3	D2	D1	D0
bit 15	bit 14	bit 13	bit 12	bit 11	bit 10	bit 9	bit 8	bit 7	bit 6	bit 5	bit 4	bit 3	bit 2	bit 1	bit 0
<b>Bit 15–8:</b>								D7: MSB from DAC input data							
<b>Bit 7–0:</b>								D7–0: The 8 bits input to Digital-to-Analog Converter							

### 3.6.5 Control Register (1A<sub>H</sub>)

The Control Register is located in address 1A<sub>H</sub>. The control register contains the input selection and the DAV pin control. (See the *FIFO* section for additional information.) The format of the Control Register is shown in Table 1–16. For more about the input selection, see the *Vecana Interface* section.

**Table 1–16. Control Registers**

R0	R0	R0	R0	R0	R0	R0	R0	R0	R0	R0	RW0	R0	RW0	RW0	RW0
0	0	0	0	0	0	0	0	0	0	0	DAV	0	I2	I1	I0
bit 15	bit 14	bit 13	bit 12	bit 11	bit 10	bit 9	bit 8	bit 7	bit 6	bit 5	bit 4	bit 3	bit 2	bit 1	bit 0

<b>Bit 15–5, 3:</b>	<b>Unused</b> (read as '0'); don't care at write
<b>Bit 4:</b>	<b>DAV:</b> The 8 bits input to Digital-to-Analog Converter 1 = DAV signal active HIGH 0 = DAV signal active LOW
<b>Bit 2–0:</b>	<b>I2–0:</b> Input channel selection bits 000 = AN3 for ADC <sub>3</sub> 001 = AX for ADC <sub>1</sub> , BX for ADC <sub>2</sub> , and AN3 for ADC <sub>3</sub> 010 = A2 via SH <sub>1</sub> for ADC <sub>1</sub> , B2 via SH <sub>3</sub> for ADC <sub>2</sub> and AN2 for ADC <sub>3</sub> 011 = A2 via SH <sub>2</sub> for ADC <sub>1</sub> , B2 via SH <sub>4</sub> for ADC <sub>2</sub> and AN2 for ADC <sub>3</sub> 100, 101, 110 = A1 for ADC <sub>1</sub> , B1 for ADC <sub>2</sub> and AN1 for ADC <sub>3</sub> 111 = IU for ADC <sub>1</sub> , IV for ADC <sub>2</sub> and IW for ADC <sub>3</sub>

# Analog Motor Control Front-End with Simultaneous Sampling on Seven S/H Capacitors and Three 1MSPS, 12-Bit, 12-Channel ADCs ADS7869



SBAS253B – MAY 2003 – REVISED NOVEMBER 2004

## 3.6.6 Counter Control/Status Register (1B<sub>H</sub>)

The Counter Control/Status Register is located in address 1B<sub>H</sub>. The counter control/status register CCTRLSTAT is a combined control register for the filtered input of the counters and a status register for the over- or under-flow status of the counters and the filtered input signals strobed by HOLD1. See the *Digital Counters* section for more information on this topic.

When the filter bits FxxE are set, the appropriate input is synchronized with the system clock and a digital filter processes the input signal. If the bit is reset, the signals are just synchronized.

The overflow states EOx/TOx are set when the appropriate counter has reached the value FFFF<sub>H</sub>. This indicates when the time, between two edges of the input signals, is greater than 4ms at 16MHz. Only the time counter keeps its value until a counter reset is performed. See the *Reset Register* section for additional information.

The filtered values of the counter inputs CNTA2, CNTA1, CNTB2 and CNTB1 are sampled with the synchronous signal HOLD1 and are stored in the appropriate bits FB1, FA1, FB2 and FA2. The format of the Counter Control/Status Register is described in Table 1–17.

**Table 1–17. Counter Control/Status Register**

R0	R0	R0	R0	R0	R0	R0	R0	R0	R0	R0	R0	RW1	RW1	RW1	RW1
FA1	FB1	FA2	FB2	0	0	0	0	EO2	TO2	EO1	TO1	FA2E	FB2E	FA1E	FB1E
bit 15	bit 14	bit 13	bit 12	bit 11	bit 10	bit 9	bit 8	bit 7	bit 6	bit 5	bit 4	bit 3	bit 2	bit 1	bit 0

<b>Bit 15:</b>	<b>FA1:</b> Synchronously strobed and filtered CNTA1 signal
<b>Bit 14:</b>	<b>FB1:</b> Synchronously strobed and filtered CNTB1 signal
<b>Bit 13:</b>	<b>FA2:</b> Synchronously strobed and filtered CNTA2 signal
<b>Bit 12:</b>	<b>FB2:</b> Synchronously strobed and filtered CNTB2 signal
<b>Bit 7:</b>	<b>EO2:</b> EDGECONT2, over- or under-flow state 1 = when EDGECONT1 reached FFFF <sub>H</sub> 0 = when EDGECONT1 is other than FFFF <sub>H</sub>
<b>Bit 6:</b>	<b>TO2:</b> TIMECOUNT2, over- or under-flow state 1 = when TIMECOUNT1 reached FFFF <sub>H</sub> 0 = when TIMECOUNT1 is other than FFFF <sub>H</sub>
<b>Bit 5:</b>	<b>EO1:</b> EDGECONT1, over- or under-flow state 1 = when EDGECONT0 reached FFFF <sub>H</sub> 0 = when EDGECONT0 is other than FFFF <sub>H</sub>
<b>Bit 4:</b>	<b>TO1:</b> TIMECOUNT1, over- or under-flow state 1 = when TIMECOUNT0 reached FFFF <sub>H</sub> 0 = when TIMECOUNT0 is other than FFFF <sub>H</sub>
<b>Bit 3:</b>	<b>FA2E:</b> Enable of digital filter input CNTA2 1 = Input signal of CNTA2 will be filtered 0 = Input signal of CNTA2 will not be filtered
<b>Bit 2:</b>	<b>FB2E:</b> Enable of digital filter input CNTB2 1 = Input signal of CNTB2 will be filtered 0 = Input signal of CNTB2 will not be filtered
<b>Bit 1:</b>	<b>FA1E:</b> Enable of digital filter input CNTA1 1 = Input signal of CNTA1 will be filtered 0 = Input signal of CNTA1 will not be filtered
<b>Bit 0:</b>	<b>FB1E:</b> Enable of digital filter input CNTB1 1 = Input signal of CNTB1 will be filtered 0 = Input signal of CNTB1 will not be filtered



### 3.6.7 Edge Count Register (1C<sub>H</sub>, 1D<sub>H</sub>, 20<sub>H</sub> and 21<sub>H</sub>)

There are four shadow registers for the two edge counters. The registers SYEDGCNT1 and SYEDGCNT2, synchronous edge count 1 (in address 1D<sub>H</sub>), and synchronous edge count 2 (in address 21<sub>H</sub>), latch the values, from the edge counters, when the synchronous hold signal HOLD<sub>1</sub> is set to low.

Registers ASEDGCNT1, ASEDGCNT2, asynchronous edge count 1 (in address 1C<sub>H</sub>), and asynchronous edge count 2 (in address 20<sub>H</sub>), latch the values from the edge counters when the asynchronous hold signal HOLD<sub>2</sub> is set to low.

An initial value is given to the edge counter 1, EDGE CNT1, by writing into the register SYEDGCNT1. An initial value is given to the edge counter 2, EDGE CNT2, by writing into the register SYEDGCNT2; see Table 1–18.

**Table 1–18. Synchronous Latched Edge Count Register**

RW0	RW0	RW0	RW0	RW0	RW0	RW0	RW0	RW0	RW0	RW0	RW0	RW0	RW0	R–	R–
D15	D14	D13	D12	D11	D10	D9	D8	D7	D6	D5	D4	D3	D2	D1	D0
bit 15	bit 14	bit 13	bit 12	bit 11	bit 10	bit 9	bit 8	bit 7	bit 6	bit 5	bit 4	bit 3	bit 2	bit 1	bit 0

<b>Bit 15–2:</b>	<b>D15–2:</b> The 14 MSBs of the synchronous latched edge counters
<b>Bit 1–0:</b>	<b>D1–0:</b> The 2 LSBs of the synchronous latched edge counters. The value is adjusted to the value of the CNTAx and CNTBx by a write access to these registers or a reset condition.

CNTAx	CNTBx	EDGE CNTx bit 1	EDGE CNTx bit 0	Position of the Angle
0	0	0	0	1st Quadrant
1	0	0	1	2nd Quadrant
1	1	1	0	3rd Quadrant
0	1	1	1	4th Quadrant

The data can only be read from the asynchronous latched registers ASEDGCNT1 and ASEDGCNT2; see Table 1–19.

**Table 1–19. Asynchronous Latched Edge Count Register**

R0	R0	R0	R0	R0	R0	R0	R0	R0	R0	R0	R0	R0	R0	R0	R0
D15	D14	D13	D12	D11	D10	D9	D8	D7	D6	D5	D4	D3	D2	D1	D0
bit 15	bit 14	bit 13	bit 12	bit 11	bit 10	bit 9	bit 8	bit 7	bit 6	bit 5	bit 4	bit 3	bit 2	bit 1	bit 0

<b>Bit 15–0:</b>	<b>D15–0:</b> The 16 bits of the asynchronous latched edge counters
------------------	---

### 3.6.8 Edge Period Register (1E<sub>H</sub> and 22<sub>H</sub>)

There are two read-only shadow registers for the two edge-period registers. The registers SYEDGPRD1 and SYEDGPRD2, synchronous edge period 1 (in address 1E<sub>H</sub>) and synchronous edge period 2 (in address 22<sub>H</sub>), latch the values from the edge period registers when the synchronous hold signal HOLD<sub>1</sub> is set to low. The Edge Period Register is described in Table 1–20.

**Table 1–20. Edge Period Register**

R0	R0	R0	R0	R0	R0	R0	R0	R0	R0	R0	R0	R0	R0	R0	R0
D15	D14	D13	D12	D11	D10	D9	D8	D7	D6	D5	D4	D3	D2	D1	D0
bit 15	bit 14	bit 13	bit 12	bit 11	bit 10	bit 9	bit 8	bit 7	bit 6	bit 5	bit 4	bit 3	bit 2	bit 1	bit 0

<b>Bit 15–0:</b>	<b>D15–0:</b> The 16 bits of the synchronous latched edge period registers
------------------	--

# Analog Motor Control Front-End with Simultaneous Sampling on Seven S/H Capacitors and Three 1MSPS, 12-Bit, 12-Channel ADCs ADS7869



SBAS253B – MAY 2003 – REVISED NOVEMBER 2004

## 3.6.9 Edge Time Period Register (1F<sub>H</sub> and 23<sub>H</sub>)

There are two read-only shadow registers for the two edge time counters. The registers SYEDGTIME1 and SYEDGTIME2, synchronous edge time 1 (in address 1F<sub>H</sub>) and synchronous edge time 2 (in address 23<sub>H</sub>), latch the values from the edge time counters when the synchronous hold signal HOLD1 is set to low. The Edge Time Register is described in Table 1–21.

**Table 1–21. Edge Time Period Register**

R0	R0	R0	R0	R0	R0	R0	R0	R0	R0	R0	R0	R0	R0	R0	R0
D15	D14	D13	D12	D11	D10	D9	D8	D7	D6	D5	D4	D3	D2	D1	D0
bit 15	bit 14	bit 13	bit 12	bit 11	bit 10	bit 9	bit 8	bit 7	bit 6	bit 5	bit 4	bit 3	bit 2	bit 1	bit 0
<b>Bit 15–0:</b>				D15–0: The 16 bits of the synchronous latched edge time counters											

## 3.6.10 FIFO Test Register (24<sub>H</sub>)

The purpose of the FIFO Test Register, in address 24<sub>H</sub>, is to test the FIFO during production test; the FIFO is filled with a defined pattern via this register. The internal FIFO structure can be verified by reading the patterns of the FIFO data register. When the FIFO test is enabled, the multiplexers are switched and lead the data (of the FIFO test register) into the FIFO, instead of the normal ADC data; to simulate the three ADCs, the data is latched into the FIFO three times. To distinguish between the channels, the first data is unchanged to simulate ADC<sub>1</sub>, the second data is inverted to simulate ADC<sub>2</sub>, and the six LSBs of the third data are inverted to simulate ADC<sub>3</sub>. While the FIFO test is enabled, a total of three data words will be stored in the FIFO, with one write instruction. In order to fill the entire FIFO register with test data, 10 writes must be performed. The test data is written into the FIFO only when the four enable bits have the value A<sub>H</sub>. **This register should not be used in normal operation.** The format of the output word is shown in Table 1–22.

**Table 1–22. FIFO Test Register**

RW0	RW0	RW0	RW0	RW0	RW0	RW0	RW0	RW0	RW0	RW0	RW0	RW0	RW0	RW0	RW0
E3	E2	E1	E0	D11	D10	D9	D8	D7	D6	D5	D4	D3	D2	D1	D0
bit 15	bit 14	bit 13	bit 12	bit 11	bit 10	bit 9	bit 8	bit 7	bit 6	bit 5	bit 4	bit 3	bit 2	bit 1	bit 0
<b>Bit 15–12:</b>				<b>E3–0:</b> Input channel address bits 0000 = Disable FIFO test ... 1001 = Disable FIFO test 1010 = Enable FIFO test write procedure 1011 = Disable FIFO test ... 1111 = Disable FIFO test											
<b>Bit 11–0:</b>				DATA11–0: The input data that will be written into the FIFO registers											

In FIFO test mode the four channel bits are copied from Bit 11 of the written data.

### 3.6.11 Comparator Test Register (25<sub>H</sub>)

The purpose of the Comparator Test Register, in address 25<sub>H</sub>, is to apply a defined pattern to the comparator output pins. This feature is for testing algorithms in the DSP or testing the hardware controlled by the comparator outputs. To enable the comparator test, the enable part of the register must contain the value 0C<sub>H</sub>. **This register should not be used in normal operation.** By reading the Comparator Test register, the comparator outputs are sent back in order to allow the host to read the actual comparator outputs in one cycle. The format of the output word is shown in Table 1–23.

**Table 1–23. Comparator Test Register**

RW0	RW0	RW0	RW0	RW0	RW0	RW–	RW–	RW–	RW–	RW–	RW–	RW–	RW–	RW–	RW–
E5	E4	E3	E2	E1	E0	A1/B2	B1	A2	B2/A1	UC	VC	WC	UI	VI	WI
bit 15	bit 14	bit 13	bit 12	bit 11	bit 10	bit 9	bit 8	bit 7	bit 6	bit 5	bit 4	bit 3	bit 2	bit 1	bit 0

<b>Bit 15–10:</b>	<b>E5–0:</b> Input channel address bits 000000 = Disable COMPARATOR_TEST ... 001011 = Disable COMPARATOR_TEST 001100 = Enable COMPARATOR_TEST write procedure 001101 = Disable COMPARATOR_TEST ... 111111 = Disable COMPARATOR_TEST
<b>Bit 9:</b>	<b>A1:</b> Control bit of position sensor, sign comparator A1 output 1 = Comparator output A1, set HIGH 0 = Comparator output A1, set LOW By reading this bit, comparator output B2 is read
<b>Bit 8:</b>	<b>B1:</b> Control bit of position sensor, sign comparator B1 output 1 = Comparator output B1, set HIGH 0 = Comparator output B1, set LOW
<b>Bit 7:</b>	<b>A2:</b> Control bit of position sensor, sign comparator A2 output 1 = Comparator output A2, set HIGH 0 = Comparator output A2, set LOW
<b>Bit 6:</b>	<b>B2:</b> Control bit of position sensor, sign comparator B2 output 1 = Comparator output B2, set HIGH 0 = Comparator output B2, set LOW By reading this bit, comparator output A1 is read
<b>Bit 5:</b>	<b>UC:</b> Control bit phase U current sign comparator 1 = Comparator output U_COMP, set HIGH 0 = Comparator output U_COMP, set LOW
<b>Bit 4:</b>	<b>VC:</b> Control bit phase V current sign comparator 1 = Comparator output V_COMP, set HIGH 0 = Comparator output V_COMP, set LOW
<b>Bit 3:</b>	<b>WC:</b> Control bit phase W current sign comparator 1 = Comparator output W_COMP, set HIGH 0 = Comparator output W_COMP, set HIGH
<b>Bit 2:</b>	<b>UI:</b> Control bit phase U current window comparator 1 = Comparator output U_ILIM, set HIGH 0 = Comparator output U_ILIM, set LOW
<b>Bit 1:</b>	<b>VI:</b> Control bit phase V current window comparator 1 = Comparator output V_ILIM, set HIGH 0 = Comparator output V_ILIM, set LOW
<b>Bit 0:</b>	<b>WI:</b> Control bit phase W current window comparator 1 = Comparator output W_ILIM, set HIGH 0 = Comparator output W_ILIM, set LOW

# Analog Motor Control Front-End with Simultaneous Sampling on Seven S/H Capacitors and Three 1MSPS, 12-Bit, 12-Channel ADCs ADS7869



SBAS253B – MAY 2003 – REVISED NOVEMBER 2004

## 3.6.12 Interrupt Register (26<sub>H</sub>)

The Interrupt Register, in address 26<sub>H</sub>, contains the interrupt source and interrupt control bits. The bits xOxF are set when a particular counter had an over- or under-flow. The bits remain set until the Interrupt register is read; this is independent of whether the counter over- or under-flow states remain or not. The counter over- or under-flow interrupt is enabled when the appropriate xOxE bits are set.

The FFF bit, FIFO full flag, will be set when the FIFO is (or was) full and remains set until the Interrupt register is read, independent of whether the FIFO is full or not. The FF bit, FIFO full, indicates whether the FIFO is full or not. The FFF bit is cleared when the Interrupt register is read. The FIFO full interrupt is enabled when the bit FFE (or FIFO full enable) is set.

The FEF bit, FIFO empty flag, will be set when the FIFO is (or was) empty and remains set until the Interrupt register is read, independent of whether the FIFO is empty or not. The FE bit, FIFO empty, indicates if the FIFO is empty or not. The bit FEF is cleared when the Interrupt register is read. The FIFO empty interrupt is enabled when the FEE bit, FIFO empty enable, is set. For more information about the Interrupt pin, see the *Interrupt* section. Table 1–24 describes the Interrupt register.

**Table 1–24. Interrupt Register**

RW0	RW0	RW0	RW0	R0	R0	R0	R0	R0	R0	R0	R0	R0	R0	RW0	RW0
EO2E	TO2E	EO1E	TO1E	EO2F	TO2F	EO1F	TO1F	0	0	FF	FE	FFF	FEF	FFE	FEE
bit 15	bit 14	bit 13	bit 12	bit 11	bit 10	bit 9	bit 8	bit 7	bit 6	bit 5	bit 4	bit 3	bit 2	bit 1	bit 0
<b>Bit 15:</b>	<b>EO2E:</b> Edge counter 2, EDGECONT2, over- or under-flow interrupt enable bit 1 = Interrupt enable 0 = Interrupt disable														
<b>Bit 14:</b>	<b>TO2E:</b> Time counter 2, TIMECOUNT2, over- or under-flow interrupt enable bit 1 = Interrupt enable 0 = Interrupt disable														
<b>Bit 13:</b>	<b>EO1E:</b> Edge counter 1, EDGECONT1, over- or under-flow interrupt enable bit 1 = Interrupt enable 0 = Interrupt disable														
<b>Bit 12:</b>	<b>TO1E:</b> Time counter 1, TIMECOUNT1, over- or under-flow interrupt enable bit 1 = Interrupt enable 0 = Interrupt disable														
<b>Bit 11:</b>	<b>EO2F:</b> Edge counter 2, EDGECONT2, over- or under-flow flag 1 = EDGECONT2 over- or under-flow occurred 0 = EDGECONT2 over- or under-flow did not occur														
<b>Bit 10:</b>	<b>TO2F:</b> Time counter 2, TIMECOUNT2, over- or under-flow flag 1 = TIMECOUNT2 over- or under-flow occurred 0 = TIMECOUNT2 over- or under-flow did not occur														
<b>Bit 9:</b>	<b>EO1F:</b> Edge counter 1, EDGECONT1, over- or under-flow flag 1 = EDGECONT1 over- or under-flow occurred 0 = EDGECONT1 over- or under-flow did not occur														
<b>Bit 8:</b>	<b>TO1F:</b> Time counter 1, TIMECOUNT1, over- or under-flow flag 1 = TIMECOUNT1 over- or under-flow occurred 0 = TIMECOUNT1 over- or under-flow did not occur														
<b>Bit 7–6:</b>	<b>Unused</b> (read as '0')														

**Interrupt Register, continued**

<b>Bit 5:</b>	<b>FF:</b> FIFO full state 1 = FIFO is full 0 = FIFO is not full
<b>Bit 4:</b>	<b>FE:</b> FIFO empty state 1 = FIFO is empty 0 = FIFO is not empty
<b>Bit 3:</b>	<b>FFF:</b> FIFO full flag 1 = FIFO is or was full 0 = FIFO is not or was not full
<b>Bit 2:</b>	<b>FEF:</b> FIFO empty flag 1 = FIFO is or was empty 0 = FIFO is not or was not empty
<b>Bit 1</b>	<b>FFE:</b> FIFO full interrupt enable bit 1 = Interrupt enable 0 = Interrupt disable
<b>Bit 0:</b>	<b>FEE:</b> FIFO empty interrupt enable bit 1 = Interrupt enable 0 = Interrupt disable

**3.6.13 Parallel Register (27<sub>H</sub>)**

The Parallel Register, in address 27<sub>H</sub>, controls the parallel interface mode 11; see the *Mode 11 Bus Access* sections. The Parallel Register has no effect on modes 00, 01, and 10. There is only one bit present in the Parallel Register, the M bit. The format of the Parallel Register is shown in Table 1–25.

**Table 1–25. Parallel Register**

R0	R0	R0	R0	R0	R0	R0	R0	R0	R0	R0	R0	R0	R0	R0	RW1
0	0	0	0	0	0	0	0	0	0	0	0	0	0	0	M
bit 15	bit 14	bit 13	bit 12	bit 11	bit 10	bit 9	bit 8	bit 7	bit 6	bit 5	bit 4	bit 3	bit 2	bit 1	bit 0
<b>Bit 15–1:</b>		<b>Unused</b> (read as '0')													
<b>Bit 0:</b>		<b>M:</b> Set up the type of the parallel interface 1 = Parallel interface, mode 11 (default) 0 = TMS320c54xx DSP family-compatible parallel interface													

# Analog Motor Control Front-End with Simultaneous Sampling on Seven S/H Capacitors and Three 1MSPS, 12-Bit, 12-Channel ADCs ADS7869



SBAS253B – MAY 2003 – REVISED NOVEMBER 2004

## 3.6.14 Reset Register (28<sub>H</sub>)

The Reset Register, in address 28<sub>H</sub>, can either reset the ADS7869 entirely, or simply reset the counters. Writing an AA<sub>H</sub> pattern to the C<sub>X</sub> bits will reset both counter 1 and counter 2, and all registers related to the counters. Writing an AA<sub>H</sub> pattern to the S<sub>X</sub> bits forces the ADS7869 into a reset state; both the digital and the analog sections are reset. The reset register is a write-only register. If the Reset register is read, the data 0000<sub>H</sub> will be received. The format of the input word is shown in Table 1–26. To reset the complete ADS7869, the pattern AAAA<sub>H</sub> should be written to the Reset register.

Once the Reset register activates a system reset, the register must not be rewritten to in order to deactivate the reset condition. Writing another pattern to the C<sub>X</sub> bits (other than AA<sub>H</sub>) deactivates a reset condition of the counters or a reset condition of the device.

For more information about reset conditions, see the *Reset* section.

**Table 1–26. Reset Register**

W0	W0	W0	W0	W0	W0	W0	W0	W0	W0	W0	W0	W0	W0	W0	W0
S7	S6	S5	S4	S3	S2	S1	S0	C7	C6	C5	C4	C3	C2	C1	C0
bit 15	bit 14	bit 13	bit 12	bit 11	bit 10	bit 9	bit 8	bit 7	bit 6	bit 5	bit 4	bit 3	bit 2	bit 1	bit 0
<b>Bit 15–8:</b>		<b>S7–0:</b> Reset control of entire ADS7869 (both digital and analog sections) 00000000 = No effect on ADS7869 ... 10101001 = No effect on ADS7869 10101010 = Reset entire ADS7869 10101011 = No effect on ADS7869 ... 11111111 = No effect on ADS7869													
<b>Bit 7–0:</b>		<b>C7–0:</b> Reset control of both counters and related registers of ADS7869 00000000 = No effect on ADS7869 ... 10101001 = No effect on ADS7869 10101010 = Reset both counters in ADS7869 10101011 = No effect on ADS7869 ... 11111111 = No effect on ADS7869													

### 3.7 FIFO

The FIFO of the ADS7869 is organized as a 32-word ring buffer with 16 bits per word, shown in Figure 1–20.

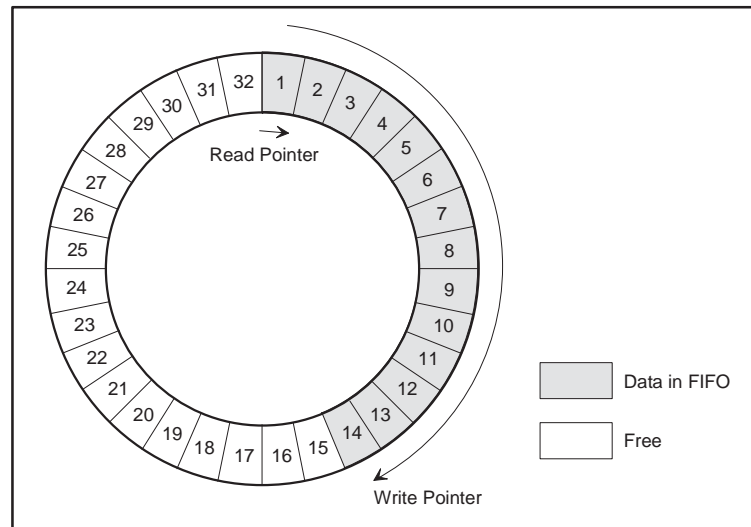

Figure 1–20. FIFO Structure

The converted data of the ADS7869 is automatically written into the FIFO. To control the writing and reading process, a write pointer and a read pointer are used. The read pointer always shows the location that contains the last read data. The write pointer indicates the location that contains the last written sample. The converted values are written in a predefined sequence to the circular buffer, beginning with ADC<sub>1</sub> and ending with ADC<sub>3</sub>. The channel number is stored with the ADC data. The data of the FIFO is read through the FIFO register at address 00<sub>H</sub>; its format is presented in Table 1–27. The table shows that the channel information for the converted channel data, is continually maintained. The address 00<sub>H</sub> in the register map shows only the data to which the read pointer is directed.

The FIFO generates the DAV signal; see Figure 1–22 on page 51. In VECANA mode, this signal is low; it indicates that the ADS7869 is converting data (see Figure 1–10 on page 26). In the other modes, the DAV indicates that data in the FIFO is available. The DAV signal can be configured as either a positive or negative signal; see the *Control Register* section.

Table 1–27. FIFO 16-bit Data Read Format

ADDRESS	D15	D14	D13	D12	D11	D10	D9	D8	D7	D6	D5	D4	D3	D2	D1	D0
00 <sub>H</sub>	0	0	0	0	ADC <sub>1</sub> value, channel IU, included offset and gain compensation											
00 <sub>H</sub>	0	0	0	1	ADC <sub>1</sub> value, channel A1, included offset and gain compensation											
00 <sub>H</sub>	0	0	1	0	ADC <sub>1</sub> value, channel A2, included offset and gain compensation											
00 <sub>H</sub>	0	0	1	1	ADC <sub>2</sub> value, channel IV, included offset and gain compensation											
00 <sub>H</sub>	0	1	0	0	ADC <sub>2</sub> value, channel B1, included offset and gain compensation											
00 <sub>H</sub>	0	1	0	1	ADC <sub>2</sub> value, channel B2, included offset and gain compensation											
00 <sub>H</sub>	0	1	1	0	ADC <sub>3</sub> value, channel IW, included offset and gain compensation											
00 <sub>H</sub>	0	1	1	1	ADC <sub>3</sub> value, channel AN1, included offset and gain compensation											
00 <sub>H</sub>	1	0	0	0	ADC <sub>3</sub> value, channel AN2, included offset and gain compensation											
00 <sub>H</sub>	1	0	0	1	ADC <sub>3</sub> value, channel AN3, included offset and gain compensation											
00 <sub>H</sub>	1	0	1	0	ADC <sub>1</sub> value, channel AX, included offset and gain compensation											
00 <sub>H</sub>	1	0	1	1	ADC <sub>2</sub> value, channel BX, included offset and gain compensation											
00 <sub>H</sub>	1	1	0	0	Not existing											
00 <sub>H</sub>	1	1	0	1	Not existing											
00 <sub>H</sub>	1	1	1	0	Not existing											
00 <sub>H</sub>	1	1	1	1	Not existing											

# Analog Motor Control Front-End with Simultaneous Sampling on Seven S/H Capacitors and Three 1MSPS, 12-Bit, 12-Channel ADCs ADS7869

SBAS253B – MAY 2003 – REVISED NOVEMBER 2004

The DAV signal becomes active when the write pointer is ahead of the read pointer. The DAV signal becomes inactive again when the read pointer equals the write pointer (that is, when the FIFO is empty).

When the ADCs are writing data into the FIFO, and the write pointer is more than 32 steps ahead of the read pointer, a FF (FIFO Full) state will be set. FF is cleared when the first FIFO read operation is performed. To synchronize the pointers after an FF state, the FIFO should be read out until a FE (FIFO Empty) occurs.

If a read is attempted, while the read and write pointers are equal, the read pointer will not increase; the same data (the data with the same channel number) is read again. When this occurs, an FE state is set. The FE state is cleared when new data is written into the FIFO. The read pointer will not go beyond the write pointer. Both FF and FE go into the Interrupt section. The functional block diagram of the FIFO is shown in Figure 1–21.

The purpose of the test data is to verify the FIFO structure for the development of an application. This is described in the *FIFO Test Register* section. **This register should not be used in normal operation.**

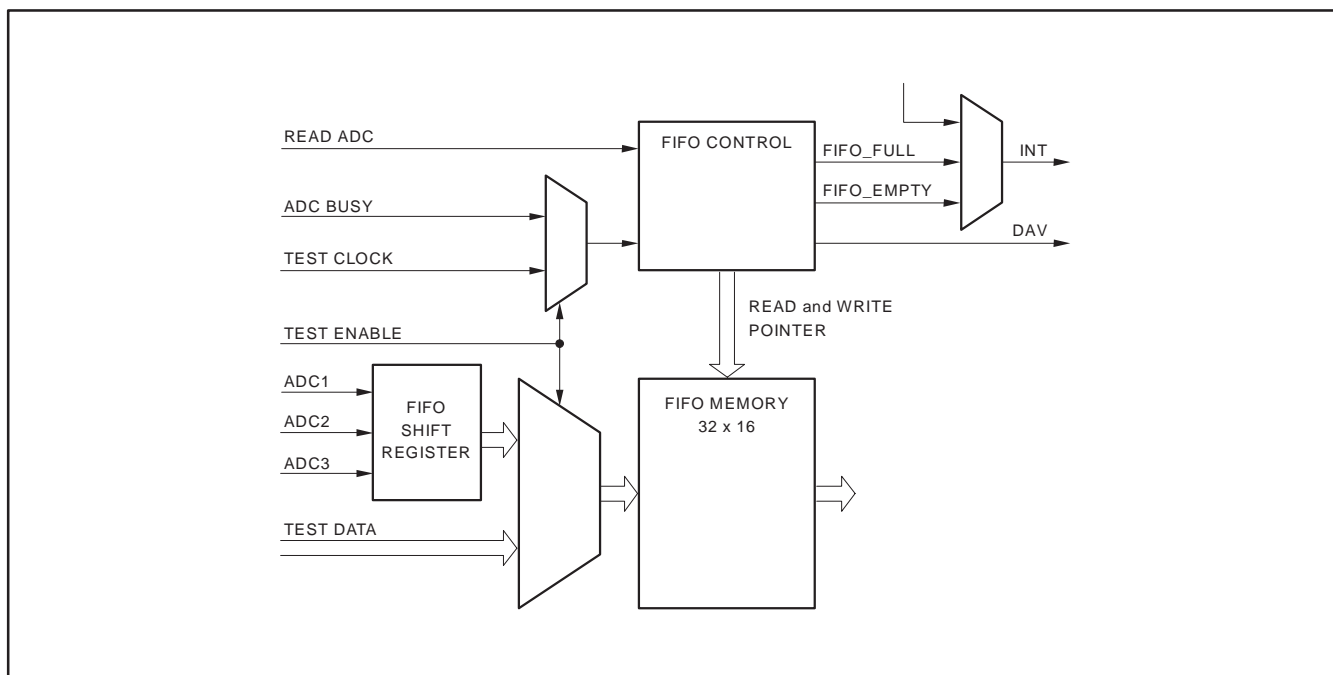

Figure 1–21. FIFO Block Diagram



### 3.7.1 DAV Timing Characteristics(1)

Over recommended operating free-air temperature range at  $-40^{\circ}\text{C}$  to  $+85^{\circ}\text{C}$ ,  $\text{AV}_{\text{DD}} = 5\text{V}$ ,  $\text{BV}_{\text{DD}} = 3\text{V} - 5\text{V}$ .

PARAMETER	SYMBOL	MIN	MAX	UNIT
Delay time from 14th rising CLK to falling DAV <sup>(2)</sup>	$t_{\text{D1}}$		50	ns
Setup time from RD HIGH to next rising CLK	$t_{\text{SU1}}$	8		ns
Delay time from rising CLK to rising DAV <sup>(2)(3)</sup>	$t_{\text{D2}}$		50	ns
Setup time from CS HIGH to next rising CLK	$t_{\text{SU2}}$	8		ns
Delay time from rising CLK to rising DAV <sup>(2)(3)</sup>	$t_{\text{D3}}$		50	ns
Setup time from SPISTE HIGH to next rising CLK	$t_{\text{SU3}}$	8		ns
Delay time from rising CLK to rising DAV <sup>(2)(3)</sup>	$t_{\text{D4}}$		50	ns

(1) All input signals are specified with  $t_{\text{R}} = t_{\text{F}} = 5\text{ns}$  (10% to 90% of  $\text{BV}_{\text{DD}}$ ) and timed from a voltage level of  $(V_{\text{IL}} + V_{\text{IH}})/2$ .

(2) With the DAV bit in the Control register (14H), the DAV signal can have opposite polarity.

(3) Only applicable when the last data is read from the FIFO

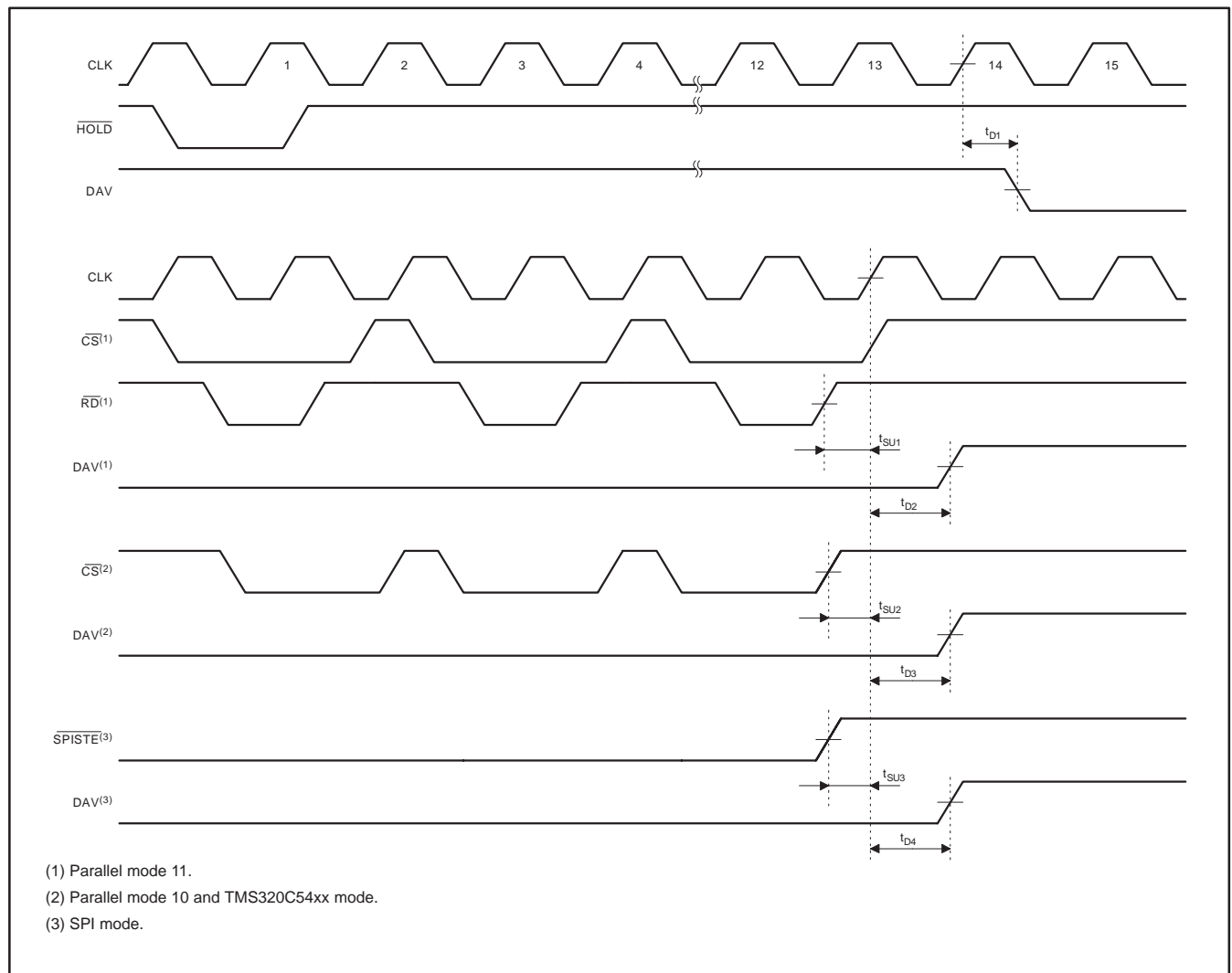

Figure 1–22. Timing of the DAV Signal

# Analog Motor Control Front-End with Simultaneous Sampling on Seven S/H Capacitors and Three 1MSPS, 12-Bit, 12-Channel ADCs ADS7869

SBAS253B – MAY 2003 – REVISED NOVEMBER 2004

## 3.8 Digital Counter Modules

The interface of the ADS7869 for the analog position sensors has the following features:

- Up to 16MHz operation frequency
- Error-safe state machine for fully four-quadrant decoding
- High noise immunity:
  - Differential signal inputs
  - Analog input comparators with hysteresis
  - Schmitt trigger digital inputs
- Digital Noise Filter
- 16-bit binary Up/Down counters with over- and under-flow detection
- Synchronous to the system clock
- Asynchronous and synchronous latching of the counter values at the same time as the ADC values are sampled and held
- Five shadow registers

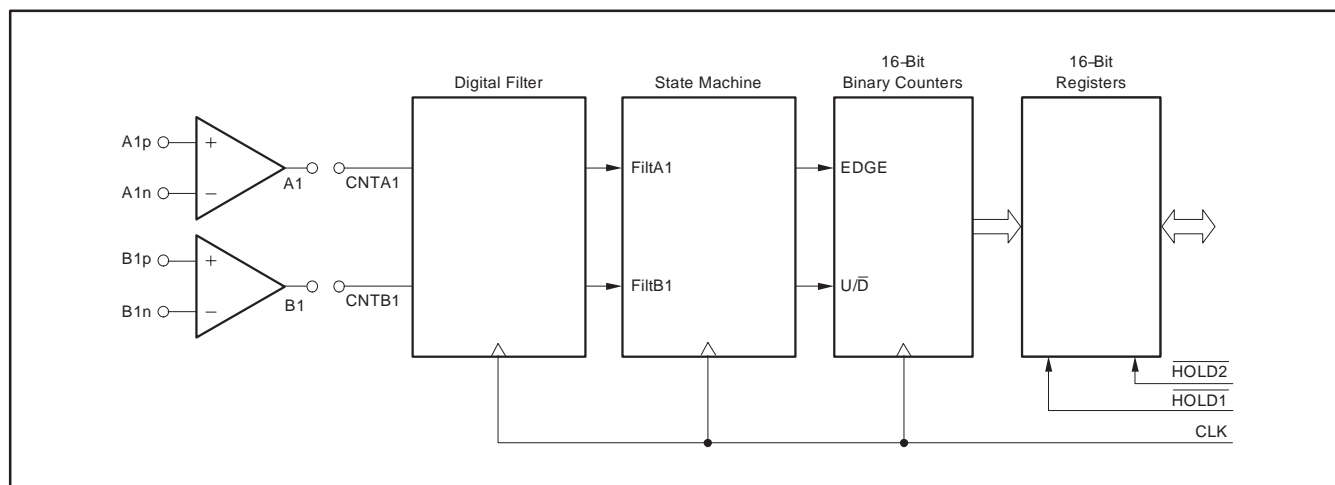

Figure 1–23. Block Diagram of a Counter Module

### 3.8.1 Operation

Analog position sensors have two signals on the output, sine and cosine. Both signals are differential and positioned at 90 electrical degrees to each other. The sign comparators, with typically 75mV hysteresis, process the position sensor output differential signal. This dramatically reduces the common-mode noise, which is present in motor control applications. The digital output signal from the comparator is connected to the counter input. Extra noise suppression is obtained with Schmitt trigger inputs. The digital signals are carried through a programmable digital filter. The filtered, glitch-free signals are processed by a state machine, which increments or decrements the counters. The counter values are then latched into corresponding registers by the synchronous or asynchronous hold signals  $\overline{\text{HOLD1}}$  and  $\overline{\text{HOLD2}}$ .

There is a counter module implemented for each pair of position sensor signals (A1, B1 and A2, B2). These counters can count upwards or downwards, depending on the direction of the position sensor signal (that is, the phase difference of the signals A1 and B1, respectively, or A2 and B2). These counter values are stored in shadow registers when the ADC channels are sampled and held. The four position sensor channels and the counter values are all sampled at the same time on the  $\overline{\text{HOLD1}}$  or  $\overline{\text{HOLD2}}$  signal.

With a 16MHz system clock, the maximum data rate that the counters will operate at is 2MHz.

### 3.8.2 Digital Noise Filter

A digital noise filter rejects noise on the incoming quadrature signal. The digital noise filter rejects large, short duration, noise spikes; false counts, triggered by noise or spikes, are also significantly suppressed. See Figure 1–24.

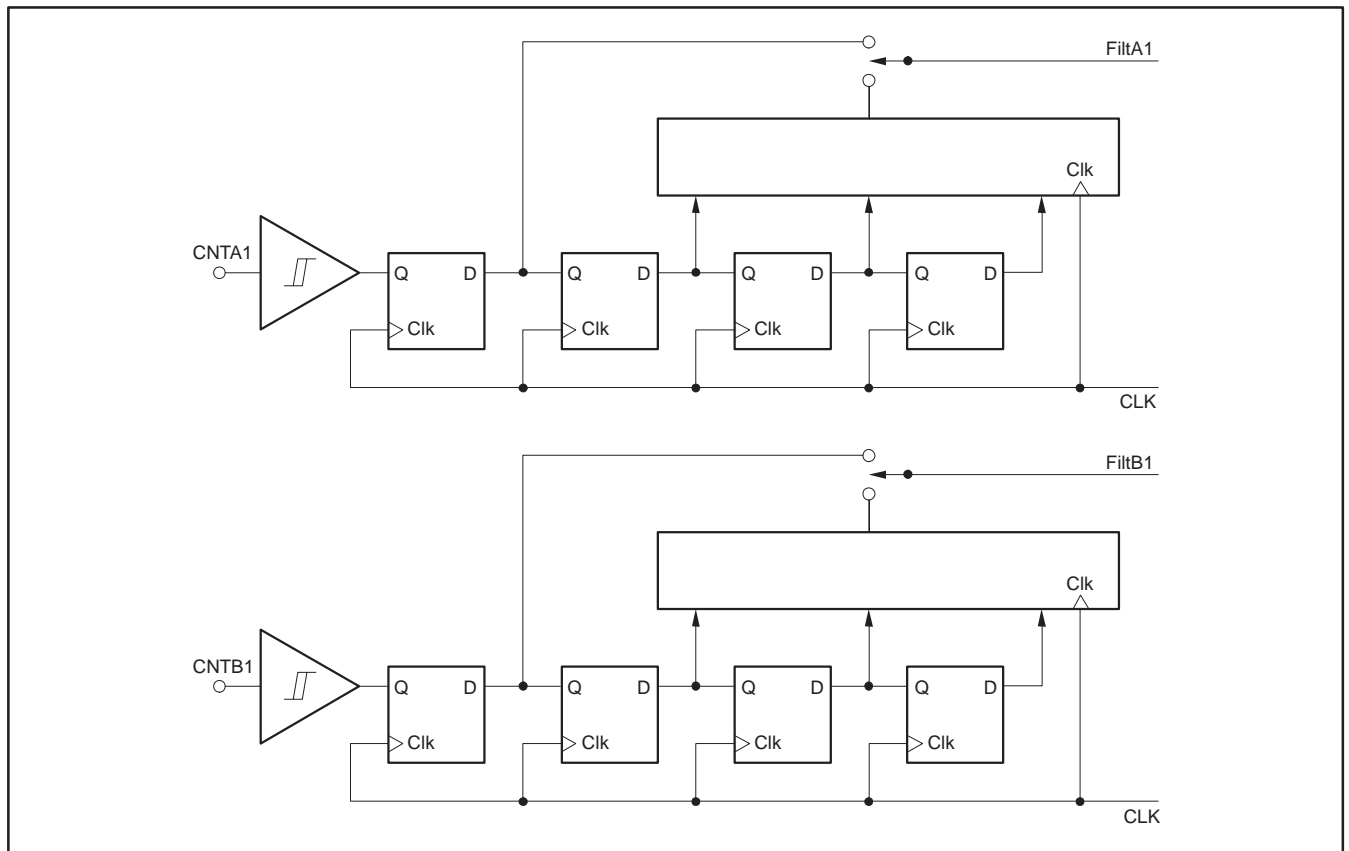

**Figure 1–24. Digital Noise Filter Block Diagram**

The input signals,  $Cnt_{XY}$ , are sampled on the rising clock edge. Before the signals are passed to the state machine, the signals must be stable for a minimum of three consecutive rising clock edges. Pulses shorter than two clock periods are rejected; glitches between rising clock edges are also ignored. See Figure 1–25.

# Analog Motor Control Front-End with Simultaneous Sampling on Seven S/H Capacitors and Three 1MSPS, 12-Bit, 12-Channel ADCs ADS7869

SBAS253B – MAY 2003 – REVISED NOVEMBER 2004

## 3.8.2.1 Filtered Timing Characteristics(1)

Over recommended operating free-air temperature range at  $-40^{\circ}\text{C}$  to  $+85^{\circ}\text{C}$ ,  $\text{AV}_{\text{DD}} = 5\text{V}$ ,  $\text{BV}_{\text{DD}} = 3\text{V} - 5\text{V}$ .

PARAMETER	SYMBOL	MIN	MAX	UNIT
CLK Period	$t_{\text{C1}}$	62.5		ns
Counter input signal, CNTA1 or CNTB1, Period	$t_{\text{C2}}$	8		$t_{\text{C1}}$
Counter input signal, CNTA1 or CNTB1, HIGH or LOW time	$t_{\text{W2}}$	4		$t_{\text{C1}}$
Delay between CNTA1 or CNTB1 signal, any combination	$t_{\text{D1}}$	2		$t_{\text{C1}}$
Filtered noise spike on CNTA1 or CNTB1 input HIGH or LOW Time	$t_{\text{W3}}$		2	$t_{\text{C1}}$

(1) All input signals are specified with  $t_{\text{R}} = t_{\text{F}} = 5\text{ns}$  (10% to 90% of  $\text{BV}_{\text{DD}}$ ) and timed from a voltage level of  $(V_{\text{IL}} + V_{\text{IH}})/2$ .

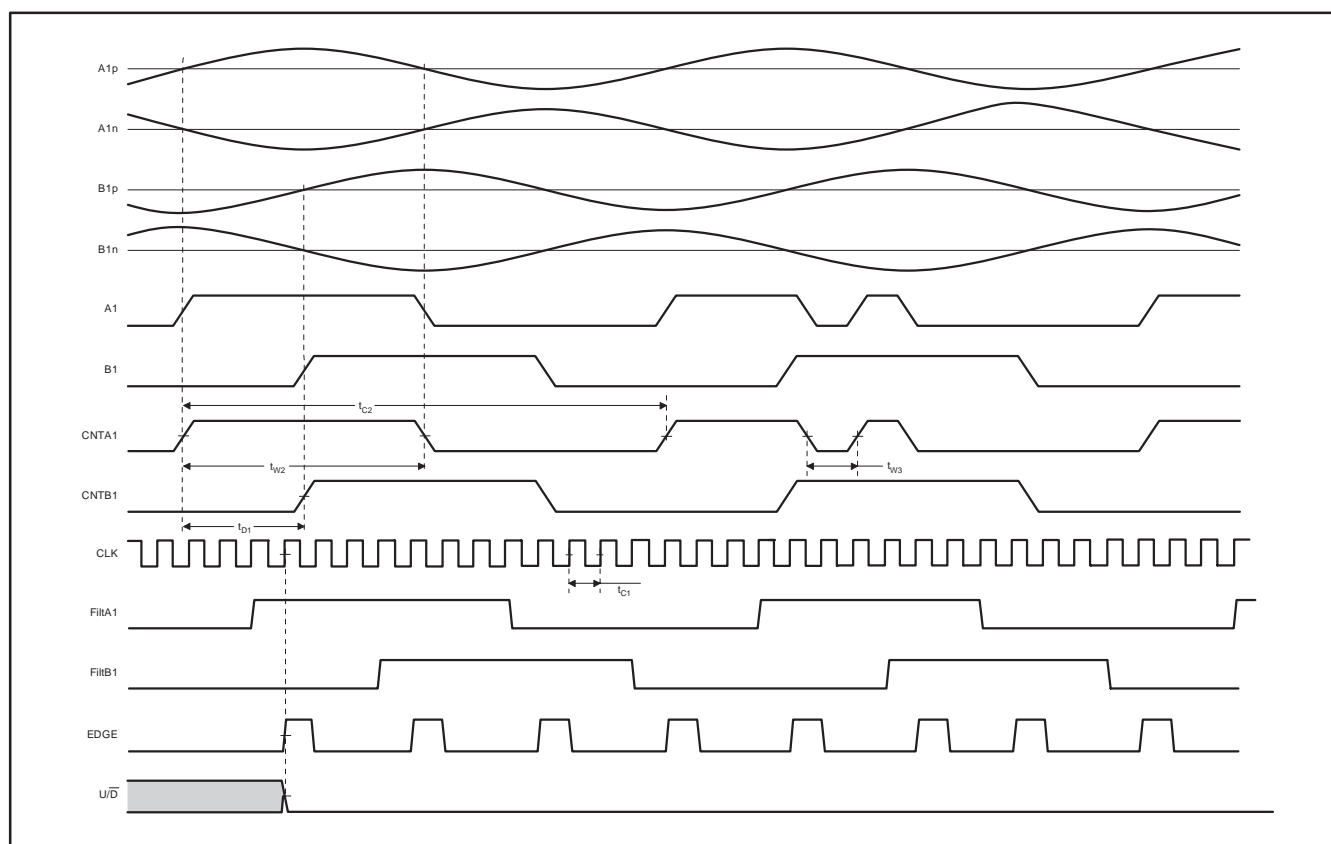

Figure 1–25. Timing Diagram of the Counter Signals with the Digital Noise Filter Enabled

### 3.8.2.2 Unfiltered Timing Characteristics(1)

Over recommended operating free-air temperature range at  $-40^{\circ}\text{C}$  to  $+85^{\circ}\text{C}$ ,  $\text{AV}_{\text{DD}} = 5\text{V}$ ,  $\text{BV}_{\text{DD}} = 3\text{V} - 5\text{V}$ .

PARAMETER	SYMBOL	MIN	MAX	UNIT
CLK Period	$t_{\text{C1}}$	62.5		ns
Counter input signal, CNTA1 or CNTB1, Period	$t_{\text{C2}}$	8		$t_{\text{C1}}$
Counter input signal, CNTA1 or CNTB1, HIGH or LOW time	$t_{\text{W2}}$	4		$t_{\text{C1}}$
Delay between CNTA1 or CNTB1 signal, any combination	$t_{\text{D1}}$	2		$t_{\text{C1}}$

(1) All input signals are specified with  $t_{\text{R}} = t_{\text{F}} = 5\text{ns}$  (10% to 90% of  $\text{BV}_{\text{DD}}$ ) and timed from a voltage level of  $(V_{\text{IL}} + V_{\text{IH}})/2$ .

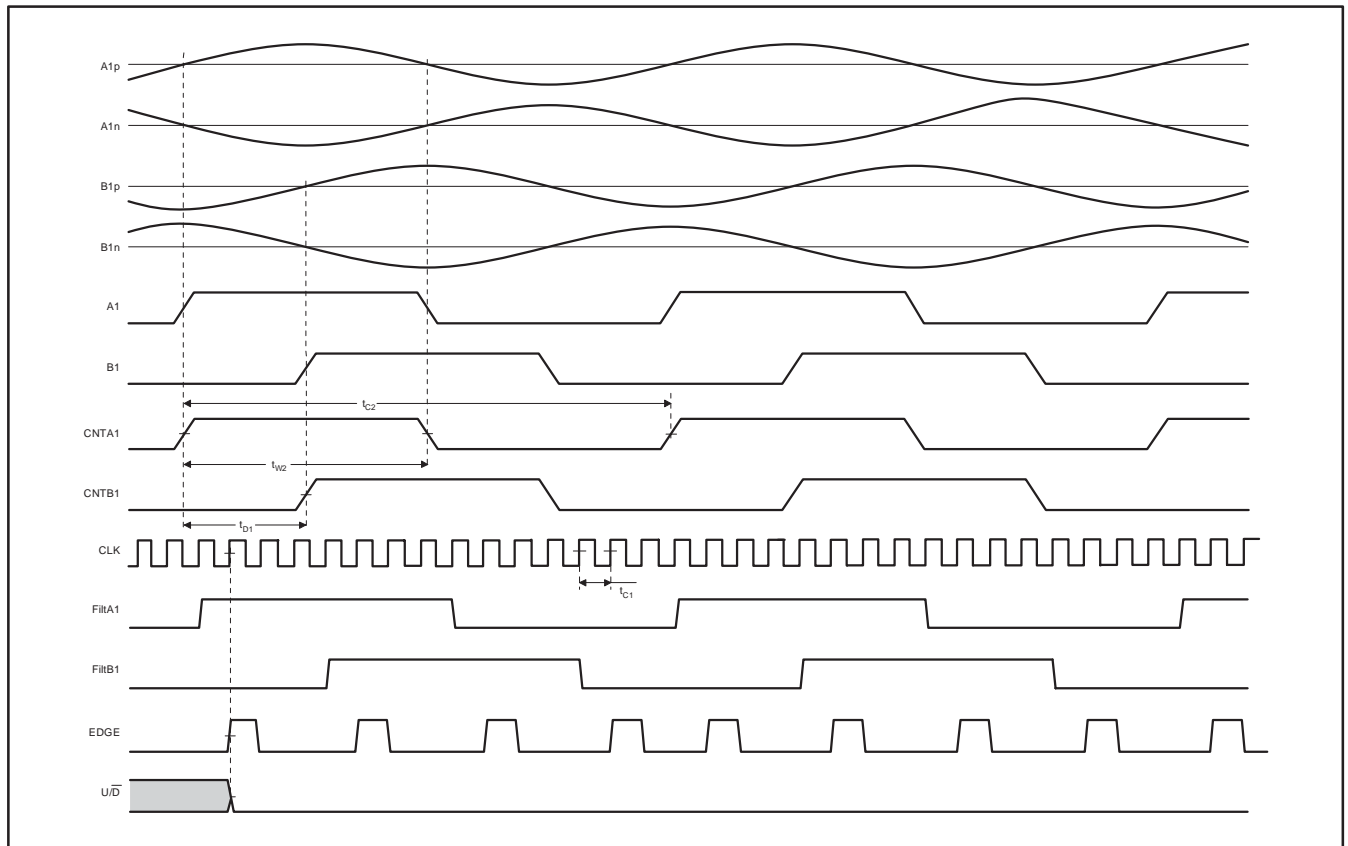

Figure 1–26. Timing Diagram of the Counter Signals with the Digital Noise Filter Disabled

# Analog Motor Control Front-End with Simultaneous Sampling on Seven S/H Capacitors and Three 1MSPS, 12-Bit, 12-Channel ADCs ADS7869

SBAS253B – MAY 2003 – REVISED NOVEMBER 2004

## 3.8.3 Binary Counters and Registers

The complete up/down counter includes two 16-bit counters and five 16-bit shadow registers. The first counter is a 16-bit up/down counter, which counts upwards or downwards on the EDGE input signal as a function of the  $U/\bar{D}$  signal. This is the coarse angle counter, and it is called EDGECNT. For the fine angle computation, the second 16-bit counter, TIMECOUNT, is implemented. This counter increments with the system clock and resets when the EDGE signal occurs. The TIMECOUNT counter cannot be decremented. The system is shown in Figure 1–27 and the timing is shown in Figure 1–28. The  $U/\bar{D}$  signal is high, counting upwards, when B1 runs before A1. The  $U/\bar{D}$  signal is low, counting downwards, when A1 runs before B1. The EDGE signal is set by every filtered edge of A1 and B1.

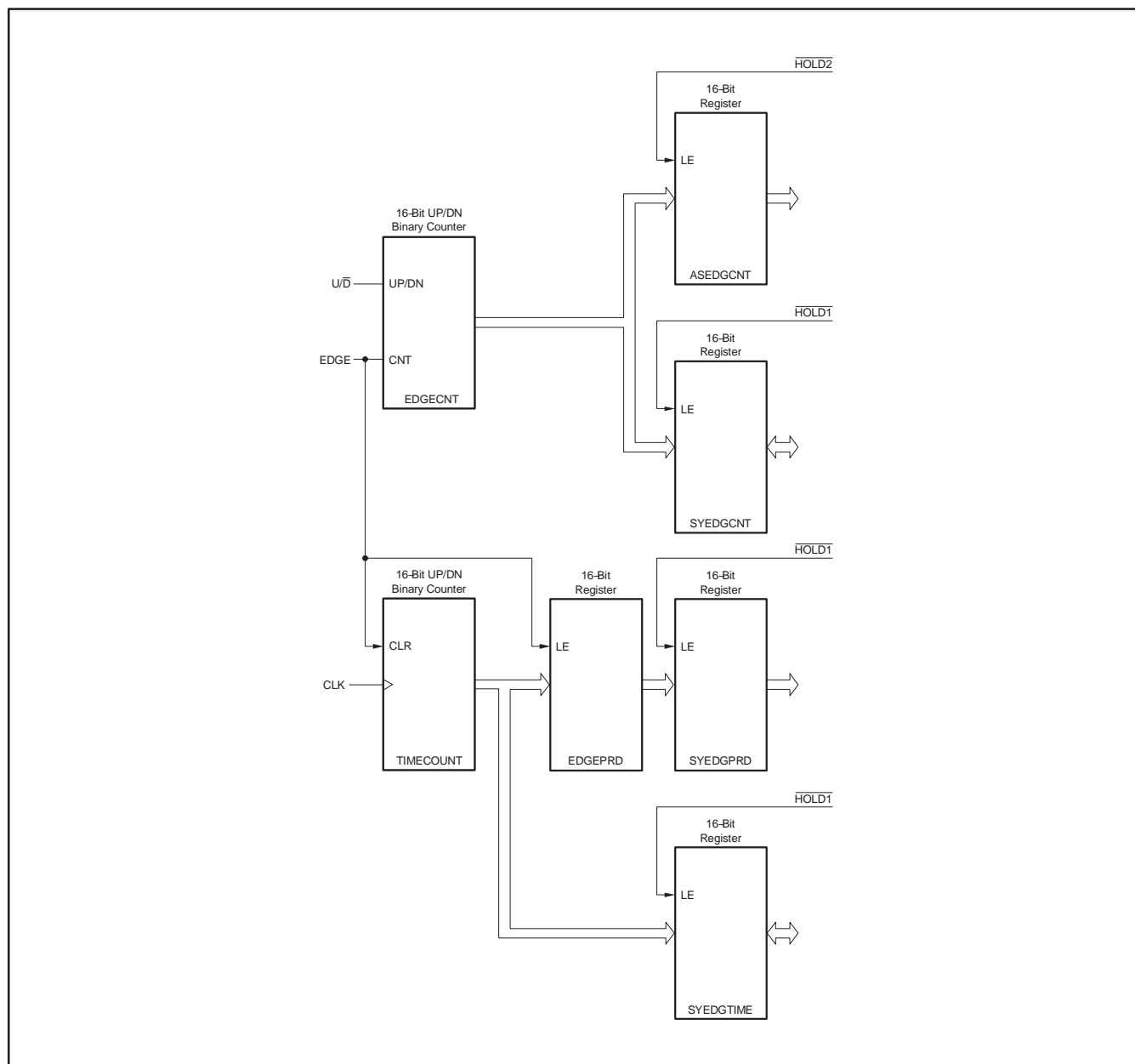
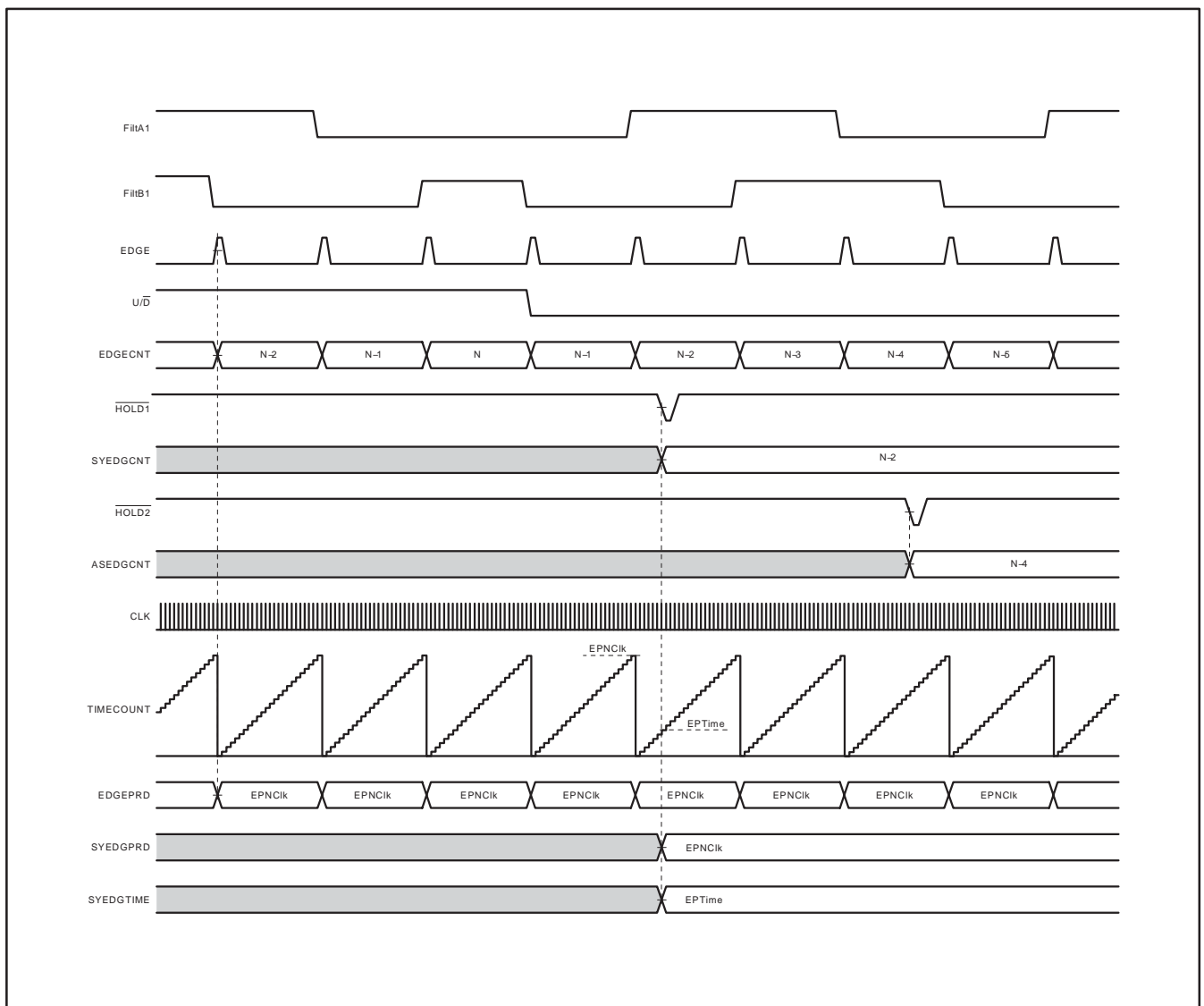

Figure 1–27. Detail Counter Block Diagram

When EDGEcnt cause an over- or under-flow, the corresponding bit in the Interrupt Register is set. The counter continues to increment or decrement in value. When the EDGE signal rises, the TIMECOUNT value is latched into the shadow register EDGEPRD. The value of EDGEPRD is the number of system clocks between two valid edges of the input signals from the comparators. This value is reciprocally proportional to the angular speed of the position sensor. The value in the EDGEPRD register is latched in the SYEDGPRD Register on the synchronous hold signal, HOLD1.

The EDGEcnt and TIMECOUNT counter values are stored into the shadow registers (SYEDGCNT and SYEDGPRD) with the synchronous hold signal, HOLD1, which samples the analog inputs. The value of the SYEDGTIME Register represents the time between the last EDGE signal and the synchronous hold signal HOLD1. The EDGEcnt counter value is stored into a shadow register ASEDGCNT on the asynchronous sample signal HOLD2.

The shadow registers SYEDGCNT, ASEDGCNT, SYEDGPRD and SYEDGTIME can be read through the register map. The counter EDGEcnt can be written through the address of the SYEDGCNT Register in the register map. The 14 MSBs of the written data are stored in the EDGEcnt register. The two LSBs are determined from the inputs FiltA1 and FiltB1; see the *Edge Count Register* section. This is to prevent inconsistency between the EDGEcnt counters and the ADC data of the position sensor input signals.



**Figure 1–28. Detail Counter Timing Diagram**

# Analog Motor Control Front-End with Simultaneous Sampling on Seven S/H Capacitors and Three 1MSPS, 12-Bit, 12-Channel ADCs ADS7869

SBAS253B – MAY 2003 – REVISED NOVEMBER 2004

## 3.9 Interrupt

The interrupt can have several sources:

- FIFO full status
- FIFO empty status
- Two TIMECOUNT over- or under-flows
- Two EDGECOUNT over- or under-flows

These six sources are combined into one interrupt signal. The interrupt signal is active high; when the interrupt pin INT is high, one of the six sources is also high.

To reset an interrupt, the Interrupt Register must be read (see *Interrupt Register* section), in order to allow the host to determine which source, or sources, caused the interrupt.

## 3.10 Reset

The ADS7869 can be forced into a reset state in three different ways:

- Power-on.
- Pulling the  $\overline{\text{RST}}$  pin (reset pin 79) low.
- Writing to the Reset Register.

In addition, the digital counters can be reset via the reset register, without resetting the entire ADS7869.

In a reset state, the analog inputs are sampled, the registers (in the register map) are forced into their reset values, and the FIFO and the counters are cleared. One rising clock pulse during a reset condition is necessary to reset the synchronous counters.

It takes one clock cycle for the ADS7869 to begin the normal operation after the last reset condition is cleared. (See Figure 1–29.)

### 3.10.1 Reset Timing Characteristics<sup>(1)</sup>

Over recommended operating free-air temperature range at  $-40^{\circ}\text{C}$  to  $+85^{\circ}\text{C}$ ,  $\text{AV}_{\text{DD}} = 5\text{V}$ ,  $\text{BV}_{\text{DD}} = 3\text{V} - 5\text{V}$ .

PARAMETER	SYMBOL	MIN	MAX	UNIT
Setup time from RST LOW to rising CLK	$t_{\text{SU1}}$	10		ns
Hold time from rising CLK to RST HIGH	$t_{\text{H1}}$	5		ns

(1) All input signals are specified with  $t_{\text{R}} = t_{\text{F}} = 5\text{ns}$  (10% to 90% of  $\text{BV}_{\text{DD}}$ ) and timed from a voltage level of  $(V_{\text{IL}} + V_{\text{IH}})/2$ .

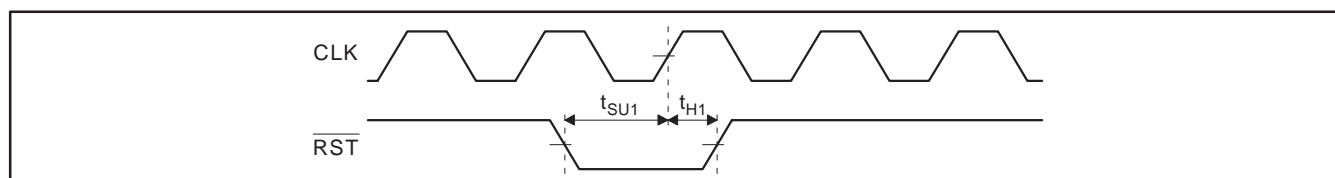

Figure 1–29. Timing Diagram of the Reset Signal  $\overline{\text{RST}}$



---

### PACKAGING INFORMATION

ORDERABLE DEVICE	STATUS(1)	PACKAGE TYPE	PACKAGE DRAWING	PINS	PACKAGE QTY
ADS7869IPZTR	ACTIVE	TQFP	PZT	100	1000

(1) The marketing status values are defined as follows:

**ACTIVE:** Product device recommended for new designs.

**LIFEBUY:** TI has announced that the device will be discontinued, and a lifetime-buy period is in effect.

**NRND:** Not recommended for new designs. Device is in production to support existing customers, but TI does not recommend using this part in a new design.

**PREVIEW:** Device has been announced but is not in production. Samples may or may not be available.

**OBSOLETE:** TI has discontinued the production of the device.

---

# MECHANICAL DATA

MTQF012B – OCTOBER 1994 – REVISED DECEMBER 1996

PZT (S-PQFP-G100)

PLASTIC QUAD FLATPACK

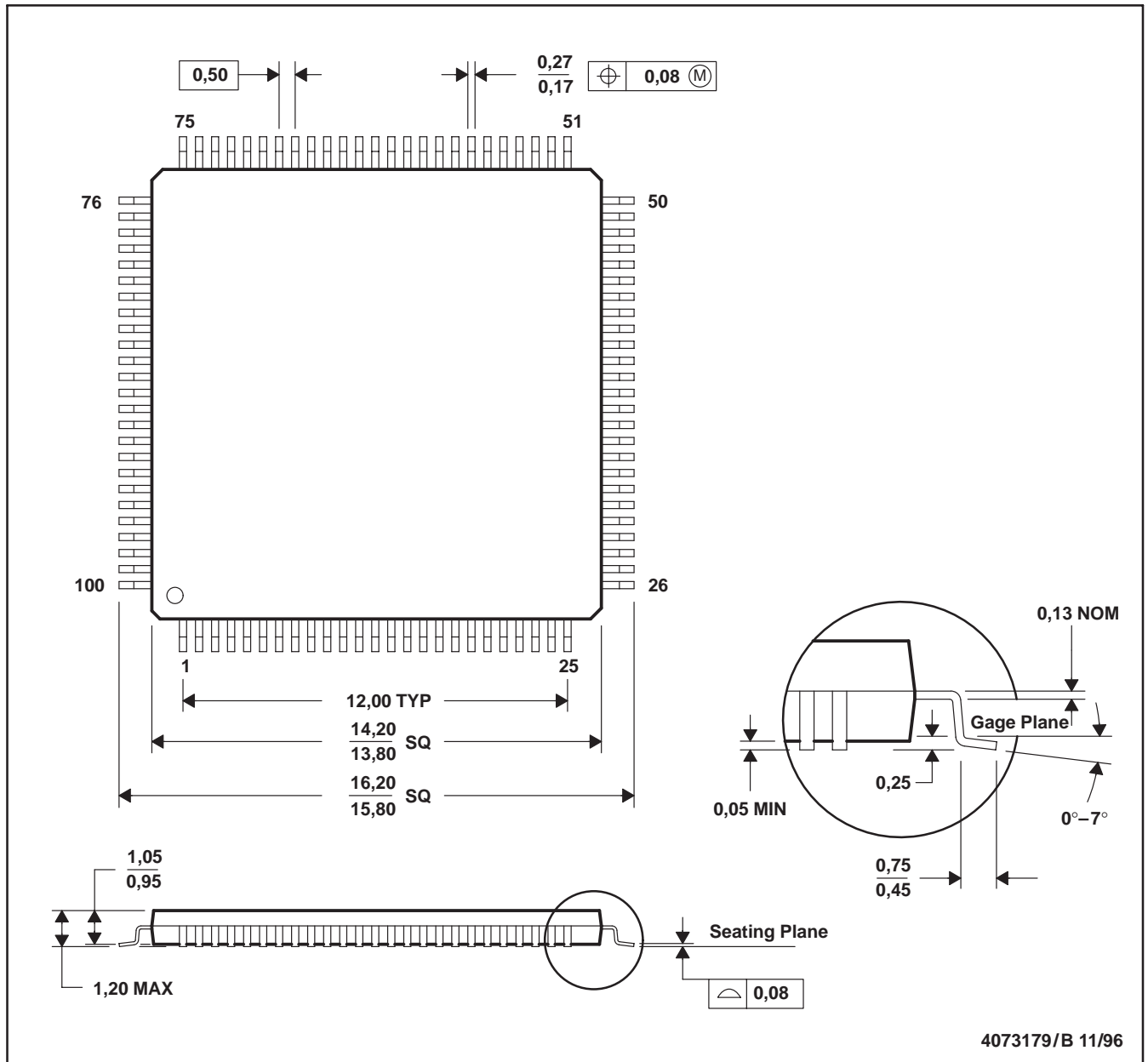

- NOTES: A. All linear dimensions are in millimeters.  
 B. This drawing is subject to change without notice.  
 C. Falls within JEDEC MS-026