

7-Unit 400mA Darlington Transistor Array

IR2403

T-43-25

# IR2403 7-Unit 400mA Darlington Transistor Array

## Description

The IR2403 is a 7-circuit driver. This IC can be used for directly driving high output current relays and LED digital display devices.

## Features

1. High output current,  $I_{OUT} = 400\text{mA}$  (MAX.)
2. High output breakdown voltage  
 $BV_{CEO} = 45\text{V}$  (MAX.)
3. Directly driven by MOS output
4. Darlington construction
5. 16-pin dual-in-line package

## Pin Connections

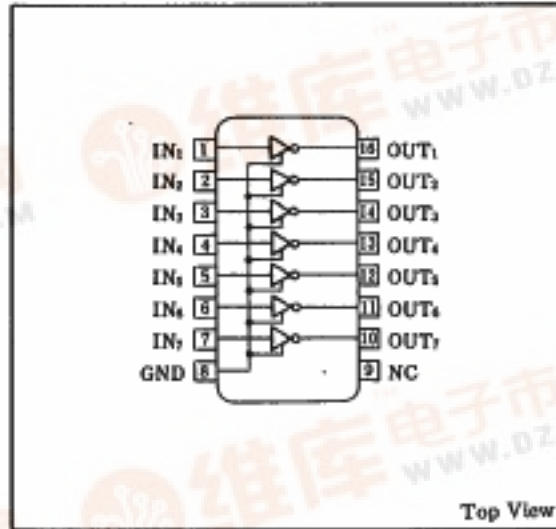

## Equivalent Circuit

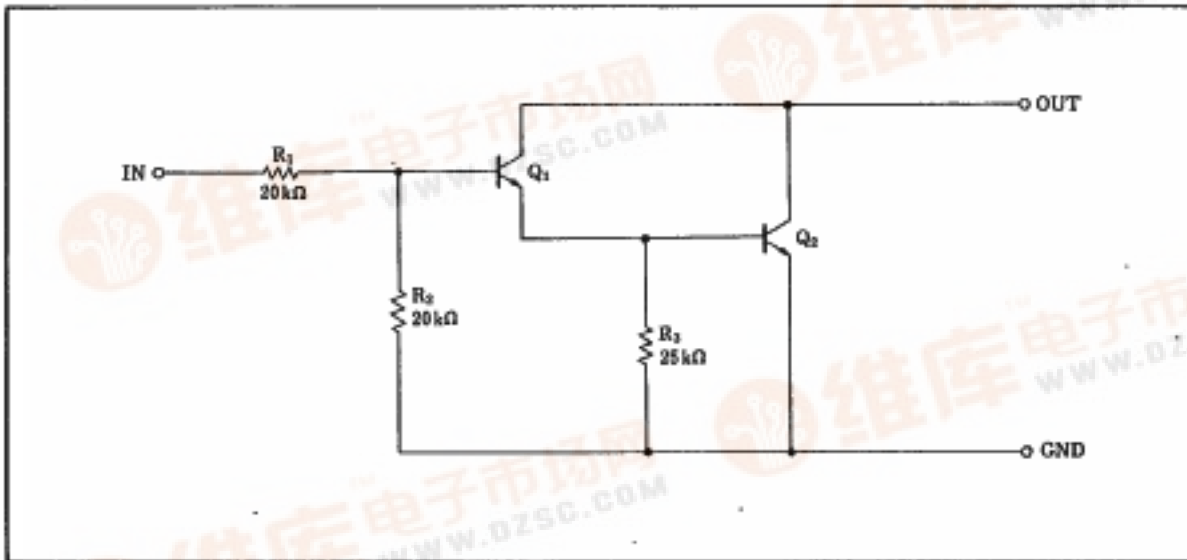

SHARP

## 7-Unit 400mA Darlingtion Transistor Array

T-43-25

IR2403

## ■ Absolute Maximum Ratings

Parameter	Symbol	Condition	Rating	Unit
Supply voltage	$V_{CC}$		45	V
Output current*1	$I_{OUT}$	Each circuit	400	mA
Input voltage	$V_{IN}$		45	V
Breakdown voltage between collector-base	$BV_{CBO}$		45	V
Breakdown voltage between collector-emitter	$BV_{CEO}$		45	V
Power dissipation	$P_D$	$T_a \leq 25^\circ\text{C}$	650	mW
$P_D$ derating ratio	$\Delta P_D/^\circ\text{C}$	$T_a > 25^\circ\text{C}$	6.5	mW/°C
Operating temperature	$T_{OPR}$		-25 - +75	°C
Storage temperature	$T_{STG}$		-55 - +125	°C

\*1 Duty cycle 8% or less, repetitive frequency 10Hz or more.

## ■ Recommended Operating Conditions

Parameter	Symbol	Condition	Rating	Unit
Max. output voltage	$V_{OM}$		45 or less	V
Operating temperature	$T_{OPR}$		-20 - +75	°C
Output current	$I_{OUT}$	at 8% duty	0~400	mA
		at 50% duty	0~150	

\* Repetitive frequency 10Hz or more.

## ■ Electrical Characteristics

 $(T_a = -25 - +75^\circ\text{C})$ 

Parameter	Symbol	Condition	MIN.	TYP.	MAX.	Unit
Supply voltage	$V_{CC}$				45	V
ON-state input current	$I_{I\ ON}$	$V_{IN} = 17\text{V}, I_{OUT} = 0\text{mA}$		0.8	1.5	mA
ON-state output voltage	$V_{O\ ON1}$	$V_{IN} = 13\text{V}, I_{OUT} = 400\text{mA}$			2.2	V
	$V_{O\ ON2}$	$V_{IN} = 13\text{V}, I_{OUT} = 200\text{mA}$			1.4	
	$V_{O\ ON3}$	$V_{IN} = 13\text{V}, I_{OUT} = 100\text{mA}$			1.2	
OFF-state output current	$I_{O\ OFF}$	$V_{IN} = 0\text{V}, V_{OUT} = 45\text{V}$			100	$\mu\text{A}$
DC current amplitude	$I_{PR}$	$V_{CE} = 2.5\text{V}, I_C = 300\text{mA}$	1,000			

## ■ Electrical Characteristic Curve

## Output current—Duty cycle Characteristics

