

IR51HD214

SELF-OSCILLATING HALF-BRIDGE

Features

- Output Power MOSFETs in half-bridge configuration
250V Rated Breakdown Voltage
- High side gate drive designed for bootstrap operation
- Bootstrap diode integrated into package
- Accurate timing control for both Power MOSFETs
Matched delay to get 50% duty cycle
Matched deadtime of 1.2us
- Internal oscillator with programmable frequency

$$f = \frac{1}{1.4 \times (R_T + 75\Omega) \times C_T}$$

- Zener clamped Vcc for offline operation
- Half-bridge output is out of phase with R_T

Description

The IR51HD214 is a high voltage, high speed, self-oscillating half-bridge. Proprietary HVIC and latch immune CMOS technologies, along with the HEXFET® power MOSFET technology, enable ruggedized single package construction. The front-end features a programmable oscillator which functions similar to the CMOS 555 timer. The supply to the control circuit has a zener clamp to simplify offline operation. The output features two HEXFETs in a half-bridge configuration with an internally set deadtime designed for minimum cross-conduction in the half-bridge. Propagation delays for the high and low side power MOSFETs are matched to simplify use in 50% duty cycle applications. The device can operate up to 250 volts.

Product Summary

V _{IN} (max)	250V
Duty Cycle	50%
Deadtime	1.2µs
R _{DS(on)}	2.0Ω
P _D (T _A = 25 °C)	2.0W

Package

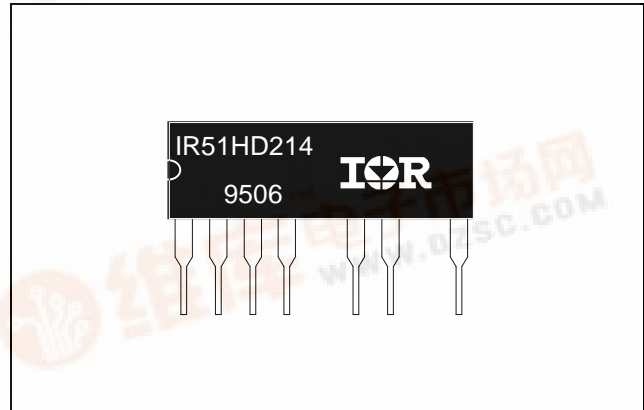

Typical Connection

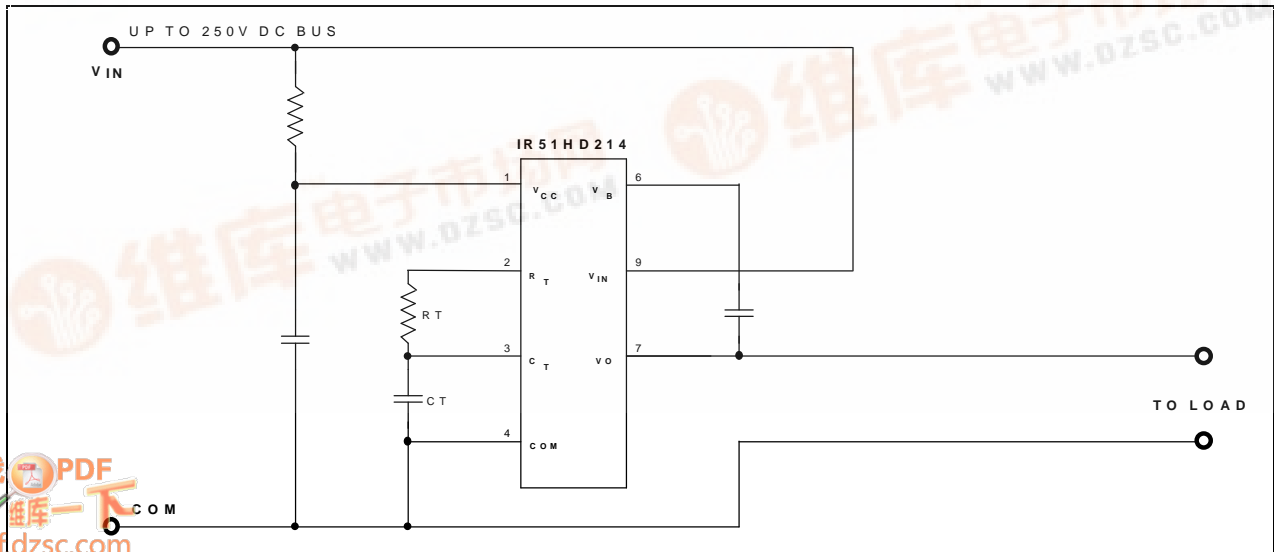

IR51HD214



Absolute Maximum Ratings

Absolute Maximum Ratings indicate sustained limits beyond which damage to the device may occur. All voltage parameters are absolute voltages referenced to COM, all currents are defined positive into any lead. The Thermal Resistance and Power Dissipation ratings are measured under board mounted and still air conditions.

Symbol	Parameter Definition	Min.	Max.	Units
V _{IN}	High Voltage Supply	-0.3	250	V
V _B	High Side Floating Supply Absolute Voltage	-0.3	275	
V _O	Half-Bridge Output Voltage	-0.3	V _{IN} + 0.3	
V _{RT}	R _T Voltage	-0.3	V _{CC} + 0.3	
V _{CT}	C _T Voltage	-0.3	V _{CC} + 0.3	
I _{CC}	Supply Current (Note 1)	---	25	mA
I _{RT}	R _T Output Current	-5	5	
dv/dt	Peak Diode Recovery dv/dt	---	4.8	V/ns
P _D	Package Power Dissipation @ T _A ≤ +25°C	---	2.00	W
R _{θJA}	Thermal Resistance, Junction to Ambient	---	60	°C/W
T _J	Junction Temperature	-55	150	°C
T _S	Storage Temperature	-55	150	
T _L	Lead Temperature (Soldering, 10 seconds)	---	300	

Recommended Operating Conditions

The Input/Output logic timing diagram is shown in Figure 1. For proper operation the device should be used within the recommended conditions.

Symbol	Parameter Definition	Min.	Max.	Units
V _B	High Side Floating Supply Absolute Voltage	VO + 10	VO + V _{CLAMP}	V
V _{IN}	High Voltage Supply	---	250	
V _O	Half-Bridge Output Voltage	---	250	
I _D	Continuous Drain Current (T _A = 25°C)	---	0.85	A
	(T _A = 85°C)	---	0.55	
I _{CC}	Supply Current (Note 1)	---	5	mA
T _A	Ambient Temperature	-40	125	°C

Note 1: Because of the IR51HD214's application specificity toward off-line supply systems, this IC contains a zener clamp structure between the chip V_{CC} and COM which has a nominal breakdown voltage of 15.6V. Therefore, the IC supply voltage is normally derived by current feeding the V_{CC} lead (typically by means of a high value resistor connected between the chip V_{CC} and the rectified line voltage and a local decoupling capacitor from V_{CC} to COM) and allowing the internal zener clamp circuit to determine the nominal supply voltage. Therefore, this circuit should not be driven by a DC, low impedance power source of greater than V_{CLAMP}.



IR51HD214

Dynamic Electrical Characteristics

$V_{BIAS} (V_{CC}, V_B) = 12V$ unless otherwise specified.

Symbol	Parameter Definition	$T_A = 25^\circ C$			Units	Test Conditions
		Min.	Typ.	Max.		
t_{rr}	Reverse Recovery Time (MOSFET Body Diode)	---	190	---	ns	$I_F = 850mA$ $di/dt = 100A/\mu s$
Q_{rr}	Reverse Recovery Charge (MOSFET Body Diode)	---	0.64	---	μC	
DT	Deadtime, LS Turn-Off to HS Turn-On & HS Turn-Off to LS Turn-On	---	1.2	---	μs	
D	R_T Duty Cycle	---	50	---	%	$f_{osc} = 20 kHz$

Static Electrical Characteristics

$V_{BIAS} (V_{CC}, V_B) = 12V$ unless otherwise specified.

Symbol	Parameter Definition	$T_A = 25^\circ C$			Units	Test Conditions
		Min.	Typ.	Max.		
Supply Characteristics						
V_{CCUV+}	V_{CC} Supply Undervoltage Positive Going Threshold	---	8.4	---	V	
V_{CCUV-}	V_{CC} Supply Undervoltage Negative Going Threshold	---	8.0	---		
I_{QCC}	Quiescent V_{CC} Supply Current	---	300	---	μA	
V_{CLAMP}	V_{CC} Zener Shunt Clamp Voltage	---	15.6	---	V	$I_{CC} = 5 mA$
Floating Supply Characteristics						
I_{QBS}	Quiescent V_{BS} Supply Current	---	30	---	μA	
I_{OS}	Offset Supply Leakage Current--	---	50	V		$B = V_{IN} = 250V$
Oscillator I/O Characteristics						
f_{OSC}	Oscillator Frequency	---	20	---	kHz	$R_T = 35.7 k\Omega$, $C_T = 1 nF$
		---	100	---		$R_T = 7.04 k\Omega$, $C_T = 1 nF$
I_{CT}	C_T Input Current	---	0.001	1.0	μA	
V_{CTUV}	C_T Undervoltage Lockout	---	100	---	$2.5V < V$	$CC < V_{CCUV+}$
V_{RT+}	R_T High Level Output Voltage, $V_{CC} - R_T$	---	20	---	mV	$I_{RT} = -100 \mu A$
		---	200	---		$I_{RT} = -1 mA$
V_{RT-}	R_T Low Level Output Voltage	---	20	---	mV	$I_{RT} = 100 \mu A$
		---	200	---		$I_{RT} = 1 mA$
V_{RTUV}	R_T Undervoltage Lockout, $V_{CC} - R_T$	---	100	---	V	$2.5V < V_{CC} < V_{CCUV+}$
V_{CT+}	2/3 V_{CC} Threshold	---	8.0	---	V	
V_{CT-}	1/3 V_{CC} Threshold	---	4.0	---	V	
Output Characteristics						
$R_{DS(on)}$	Static Drain-to-Source On-Resistance	---	2.0	---	Ω	$I_D = 850mA$
V_{SD}	Diode Forward Voltage	---	0.8	---	V	$T_i = 150^\circ C$

IR51HD214



Functional Block Diagram

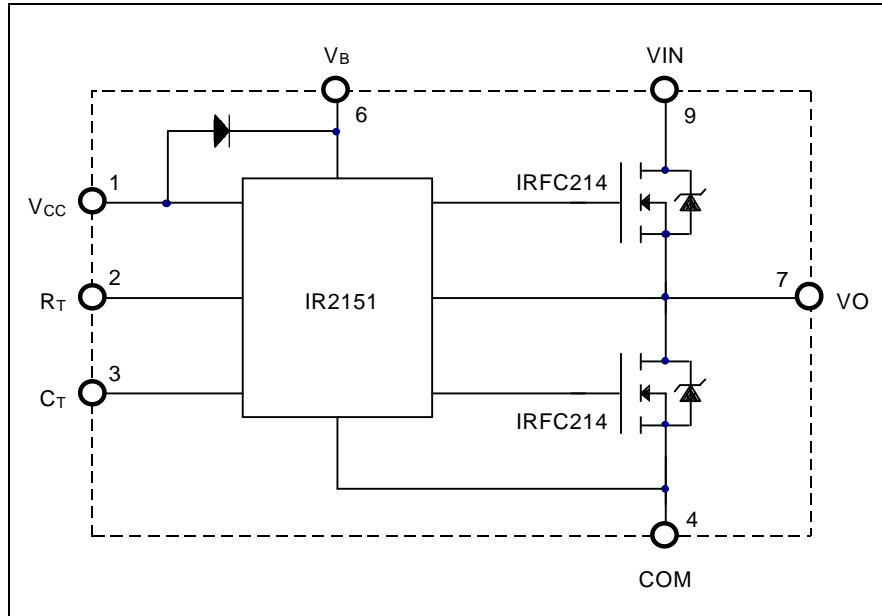

Lead Definitions

Symbol	Lead Description
V _{CC}	Logic and internal gate drive supply voltage. An internal zener clamp diode at 15.6 V nominal is included to allow the V _{CC} to be current fed directly from V _{IN} typically by means of a high value resistor.
R _T	Oscillator timing resistor input; a resistor is connected from R _T to C _T . R _T is out of phase with the half-bridge output (VO).
C _T	Oscillator timing capacitor output; a capacitor is connected from C _T to COM in order to program the oscillator frequency according to the following equation: $f = \frac{1}{1.4 \times (R_T + 75\Omega) \times C_T}$ where 75Ω is the effective impedance of the R _T output stage.
V _B	High side gate drive floating supply. For bootstrap operation a high voltage fast recovery diode is needed to feed from V _{CC} to V _B .
V _{IN}	High voltage supply.
VO	Half-bridge output.
COM	Logic and low side of half-bridge return.



IR51HD214

Lead Assignments

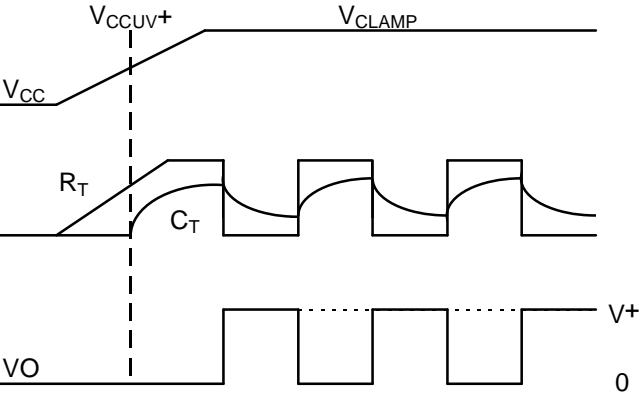
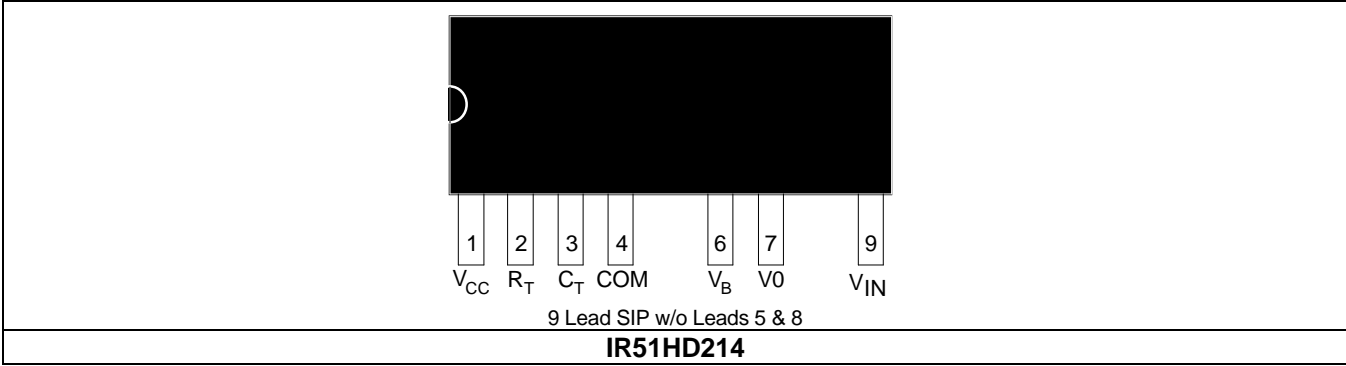

Figure 1. Input/Output Timing Diagram

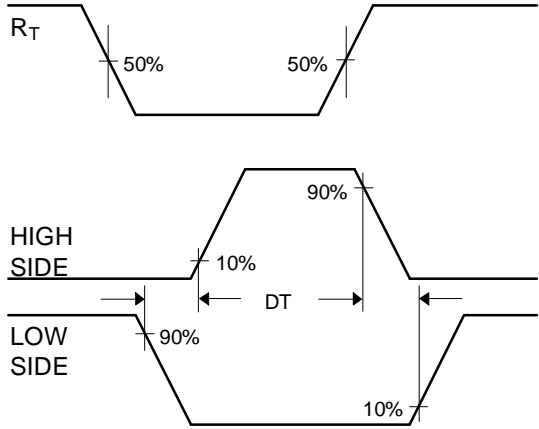
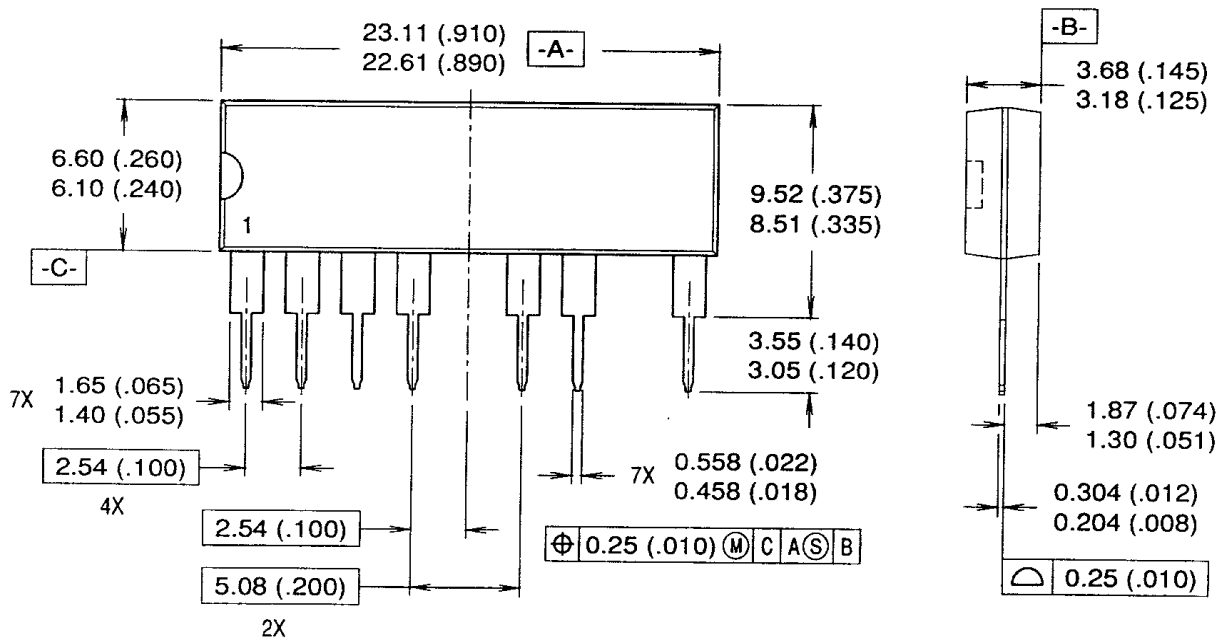

Figure 2. Deadtime Waveform Definitions

IR51HD214



NOTES:

1. DIMENSIONING & TOLERANCING PER ANSI Y14.5M-1982.
2. CONTROLLING DIMENSION: INCH.
3. DIMENSIONS ARE SHOWN IN MILLIMETERS (INCHES).

Package Outline

International
IOR Rectifier

WORLD HEADQUARTERS: 233 Kansas St., El Segundo, California 90245, Tel: (310) 322 3331
 EUROPEAN HEADQUARTERS: Hurst Green, Oxted, Surrey RH8 9BB, UK Tel: ++ 44 1883 732020
 IR CANADA: 7321 Victoria Park Ave., Suite 201, Markham, Ontario L3R 2Z8, Tel: (905) 475 1897
 IR GERMANY: Saalburgstrasse 157, 61350 Bad Homburg Tel: ++ 49 6172 96590
 IR ITALY: Via Liguria 49, 10071 Borgaro, Torino Tel: ++ 39 11 451 0111
 IR FAR EAST: 171 (K&H Bldg.), 30-4 Nishi-ikebukuro 3-Chome, Toshima-ku, Tokyo Japan Tel: 81 3 3983 0086
 IR SOUTHEAST ASIA: 315 Outram Road, #10-02 Tan Boon Liat Building, Singapore 0316 Tel: 65 221 8371
<http://www.irf.com>

Sales Offices, Agents and Distributors in Major Cities Throughout the World.

Data and specifications subject to change without notice.