

International IR Rectifier

IR6220

INTELLIGENT HIGH SIDE MOSFET POWER SWITCH

Features

- PWM Current Limit for Short Circuit Protection
- Over-Temperature Protection
- Active Output Negative Clamp
- Reverse Battery Protection
- Broken Ground Protection
- Short to VCC Protection
- Low Noise Charge Pump
- Sleep Mode Supply Current
- 4kV ESD Protection On All Pins
- Logic Ground Isolated From Power Ground

General Description:

The IR6220 is a 5 terminal monolithic HIGH SIDE SWITCH with built in short circuit, over-temperature, ESD, inductive load turn off capability and diagnostic feedback.

The on-chip protection circuit goes into PWM mode, limiting the average current during short circuit if the drain current exceeds 5A. The protection circuit latches off the high side switch if the junction temperature exceeds 170°C and latches on after the junction temperature falls by 10°C. The drain to source voltage is actively clamped at 55V, improving its performance during turn off with inductive loads.

The on-chip charge pump high side driver stage is floating and referenced to the source of the power MOSFET. Thus the logic to power ground isolation can be as high as 50V. This allows operation with larger offset as well as controlling the switch during load energy recirculation or regeneration.

A diagnostic pin is provided for status feedback of short circuit, over temperature and open load detection.

Block Diagram

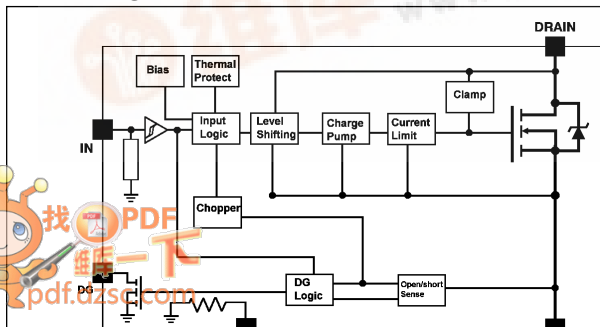

$V_{CC(OP)}$	5v-50v
$R_{ds(on)}$	100mΩ
I_{lim}	10A
$T_{j(sd)}$	170°C
E_{av}	200mJ

Applications

- Solenoid Driver
- DC Motor Driver

Truth Table

Condition	In	Out	Dg
Normal	H	H	H
Normal	L	L	L
Output Open	H	H	H
Output Open	L	H	H
Shorted Output	H	Current-Limiting	L
Shorted Output	L	L	L
Over-Temperature	H	L	L
Over-Temperature	L	L	L

Available Packages

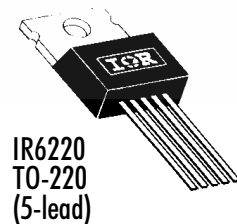

IR6220

International
IR Rectifier

Absolute Maximum Ratings

Absolute Maximum Ratings indicate sustained limits beyond which damage to the device may occur. ($T_c = 25^\circ\text{C}$ unless otherwise specified.)

		Minimum	Maximum	Units	Test Conditions	
V _{cc}	Supply Voltage	Permanent	-0.3	50	V	Pin 3 to Pin 1 (1), for 10 seconds
		Reverse	-16	—		
V _{offset}	Logic to Power Ground Offset	V _{cc} - 50	V _{cc} + 0.3			
V _{in}	Input Voltage	-0.3	30			
I _{in}	Input Current	—	10	mA		
V _{out}	Output Voltage	V _{cc} - 50	V _{cc} + 0.3	V		
I _{out}	Output Current	Self-limited				
V _{dg}	Diagnostic Output Voltage	-0.3	30	V		
I _{dg}	Diagnostic Output Current	—	10	mA		
E _{av}	Repetitive Avalanche Energy	—	200	mJ	I = 2A (2)	
ESD1	Electrostatic Discharge (Human Body Model)	—	4000	V	C = 100 pF, R = 1500Ω	
ESD2	Electrostatic Discharge (Machine Model)	—	1000	V	C = 200 pF, R = 0Ω	
PD	Power Dissipation	—	28	W	T _{case} = 25°C	
T _{Jop}	Operating Junction Temperature Range	-40	Self-limited			
T _{Stg}	Storage Temperature Range	-40	175			
T _L	Lead Temperature (Soldering, 10 seconds)	—	300			

NOTES: (1) with 15k Ω resistors in input and diagnostic

(2) maximum frequency depends on heatsink (rectangular waveform)

Static Electrical Characteristics

($T_c = 25^\circ\text{C}$ unless otherwise specified.)

		Minimum	Typical	Maximum	Units	Test Conditions
V _{ccop}	Operating Voltage Range	5	—	50	V	
I _{ccoff}	Sleep Mode Supply Current	—	40	—	μA	V _{cc} = 24V, V _{in} = 0V
I _{ccon}	Supply Current (Average)	—	3	—	mA	V _{in} = 5V
I _{ccac}	Supply Current (AC RMS)	—	20	—	μA	V _{in} = 5V
V _{ih}	High Level Input Threshold Voltage	—	2	2.5	V	
V _{il}	Low Level Input Threshold Voltage	1	1.8	—		
I _{ion}	On-State Input Current	10	—	70	μA	V _{in} = 3.5V
I _{loff}	Off-State Input Current	1	—	30		V _{in} = 0.4V
I _{oh}	Output Leakage Current	—	20	—		V _{out} = 6V
I _{ol}	Output Leakage Current	0	—	10		V _{out} = 0V
V _{dgl}	Low Level Diagnostic Output Voltage	—	0.3	—	V	I _{dg} = 1.6mA
I _{dgh}	Diagnostic Output Leakage Current	0	—	10	μA	V _{dg} = 5V
R _{DS(on)}	On-State Resistance	—	80	100	mΩ	I _{out} = 1A
		—	120	—		V _{cc} = 5V, I _{out} = 1A

Switching Electrical Characteristics

(V_{CC} = 14V, Resistive Load (R_L) = 12Ω, T_C = 25°C.)

		Minimum	Typical	Maximum	Units	Test Conditions
t _c	Over-Current Cycle Time	—	5	—	ms	
D _c	Over-Current Duty Cycle	—	10	—	%	
t _{on}	Turn-On Delay Time to 90%	—	50	—	μs	
t _{off}	Turn-Off Delay Time to 10%	—	60	—		
dv/dt _{on}	Slew Rate On	—	3	—	V/μs	
dv/dt _{off}	Slew Rate Off	—	5	—		

Protection Characteristics

		Minimum	Typical	Maximum	Units	Test Conditions	
I_{lim}	Internal Current Limit	—	10	—	A		
V_{sc}	Short Circuit Detection Voltage	—	3.5	—	V		
V_{slh}	Open Load Detection Voltage	—	3.5	—			
V_{cl1}	Output Negative Clamp	50	54	—			$I_{out} = 10mA$
V_{cl2}	Output Negative Clamp	—	56	62			$I_{out} = 2A$

Thermal Characteristics

		Minimum	Typical	Maximum	Units	Test Conditions
T_{isd}	Thermal Shutdown Temperature	—	170	—	°C	
T_{hys}	Thermal Hysteresis	—	5	—		
R_{thjc}	Thermal Resistance, Junction to Case	—	3.5	—	°C/W	
R_{thja}	Thermal Resistance, Junction to Ambient	—	50	—		

IR6220

International
IR Rectifier

Case Outline — TO-220 (IR6220)

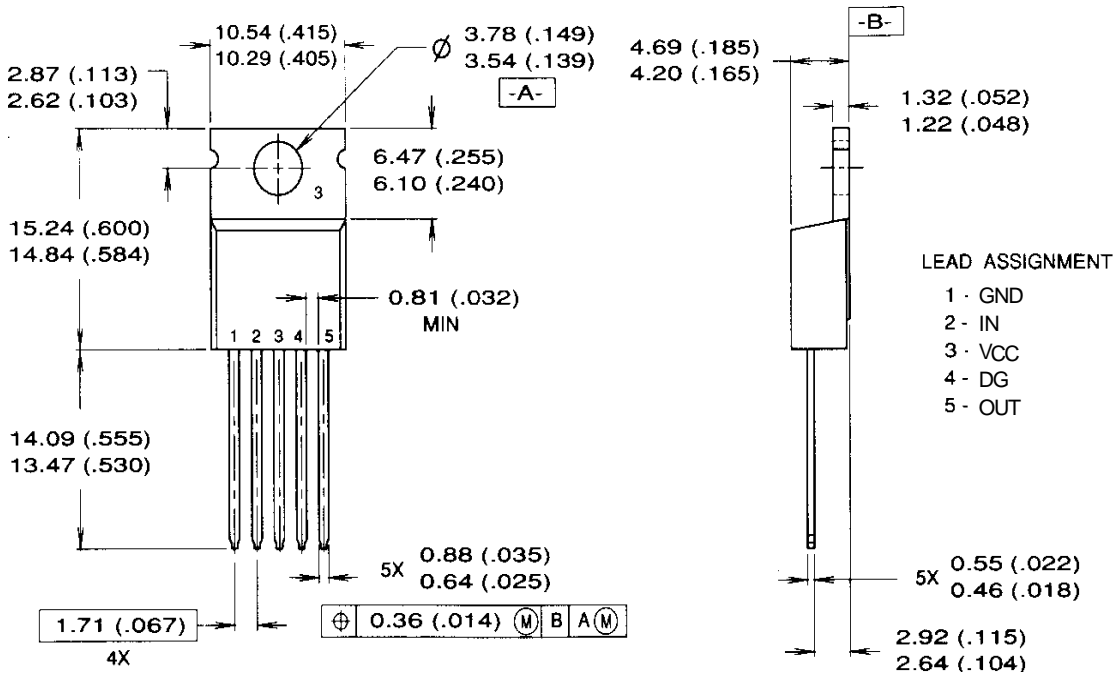

NOTES:

1. Dimensioning and tolerancing per ANSI Y14.5M, 1982
2. Controlling dimension: INCH
3. Dimensions shown are in millimeters (inches)
4. Heatsink and lead measurements do not include burrs.

International
IR Rectifier

WORLD HEADQUARTERS: 233 Kansas St., El Segundo, California 90245, Tel: (310) 322 3331

EUROPEAN HEADQUARTERS: Hurst Green, Oxted, Surrey RH8 9BB, UK Tel: ++ 44 1883 732020

IR CANADA: 7321 Victoria Park Ave., Suite 201, Markham, Ontario L3R 2Z8, Tel: (905) 475 1897

IR GERMANY: Saalburgstrasse 157, 61350 Bad Homburg Tel: ++ 49 6172 96590

IR ITALY: Via Liguria 49, 10071 Borgaro, Torino Tel: ++ 39 11 451 0111

IR FAR EAST: K&H Bldg., 2F, 3-30-4 Nishi-Ikeburo 3-Chome, Toshima-Ki, Tokyo Japan 171 Tel: 81 3 3983 0086

IR SOUTHEAST ASIA: 315 Outram Road, #10-02 Tan Boon Liat Building, Singapore 0316 Tel: 65 221 8371

<http://www.irf.com/>

Data and specifications subject to change without notice

12/96