

## 128K x 8 HIGH-SPEED CMOS STATIC RAM 3.3V REVOLUTIONARY PINOUT

DECEMBER 2005

### FEATURES

- High-speed access times:  
8, 10, 12 ns
- High-performance, low-power CMOS process
- Multiple center power and ground pins for greater noise immunity
- Easy memory expansion with  $\overline{CE}$  and  $\overline{OE}$  options
- $\overline{CE}$  power-down
- Fully static operation: no clock or refresh required
- TTL compatible inputs and outputs
- Single 3.3V power supply
- Packages available:
  - 32-pin 300-mil SOJ
  - 32-pin 400-mil SOJ
  - 32-pin TSOP (Type II)
  - 32-pin STSOP (Type I)
  - 36-pin BGA (8mmx10mm)
- Lead-free Available

### DESCRIPTION

The *ISSI* IS63LV1024/IS63LV1024L is a very high-speed, low power, 131,072-word by 8-bit CMOS static RAM in revolutionary pinout. The IS63LV1024/IS63LV1024L is fabricated using *ISSI*'s high-performance CMOS technology. This highly reliable process coupled with innovative circuit design techniques, yields higher performance and low power consumption devices.

When  $\overline{CE}$  is HIGH (deselected), the device assumes a standby mode at which the power dissipation can be reduced down to 250  $\mu$ W (typical) with CMOS input levels.

The IS63LV1024/IS63LV1024L operates from a single 3.3V power supply and all inputs are TTL-compatible.

### FUNCTIONAL BLOCK DIAGRAM

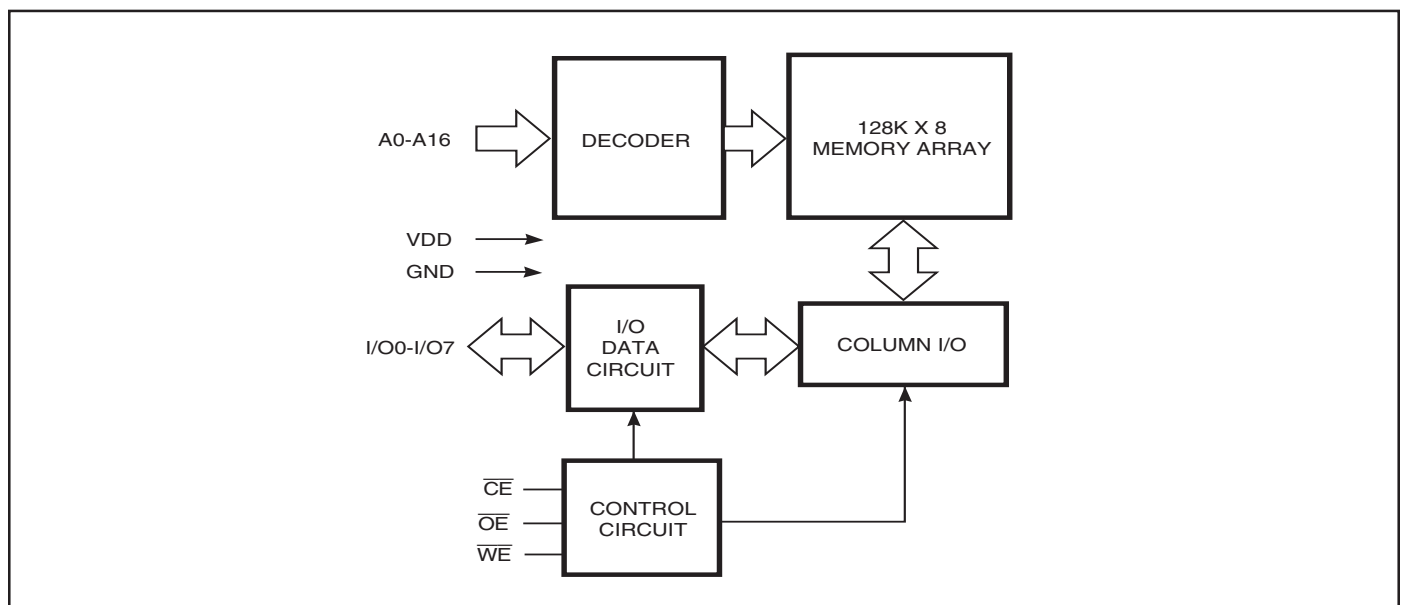

Copyright © 2005 Integrated Silicon Solution, Inc. All rights reserved. ISSI reserves the right to make changes to this specification and its products at any time without notice. ISSI assumes no liability arising out of the application or use of any information, products or services described herein. Customers are advised to obtain the latest version of this device specification before relying on any published information and before placing orders for products.

**PIN CONFIGURATION**  
32-Pin SOJ

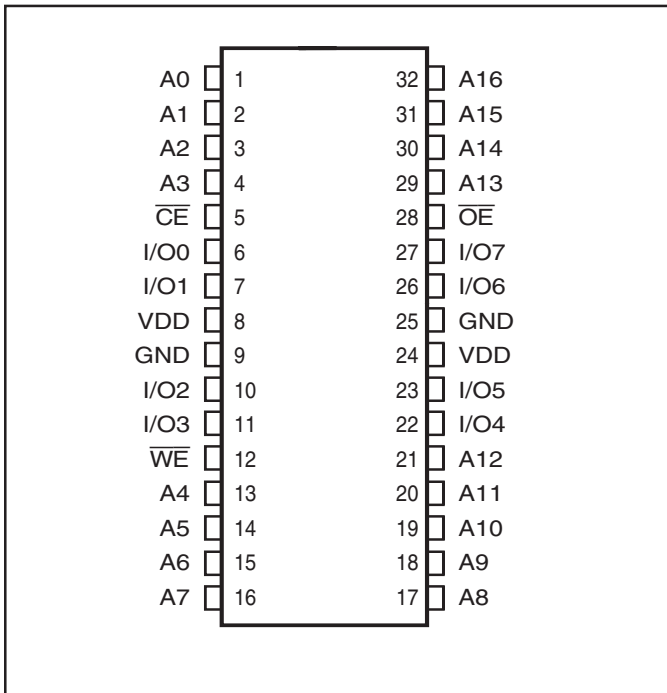

**PIN CONFIGURATION**  
32-Pin TSOP (Type II) (T)  
32-Pin STSOP (Type I) (H)

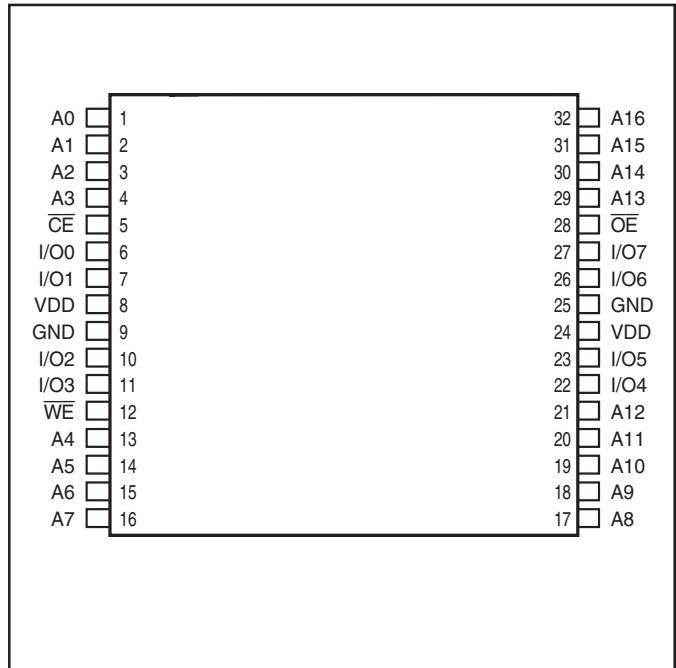

**PIN DESCRIPTIONS**

A0-A16	Address Inputs
$\overline{CE}$	Chip Enable Input
$\overline{OE}$	Output Enable Input
$\overline{WE}$	Write Enable Input
I/O0-I/O7	Data Inputs/Outputs
VDD	Power
GND	Ground

**PIN CONFIGURATION**  
36-mini BGA (B) (8 mm x 10 mm)

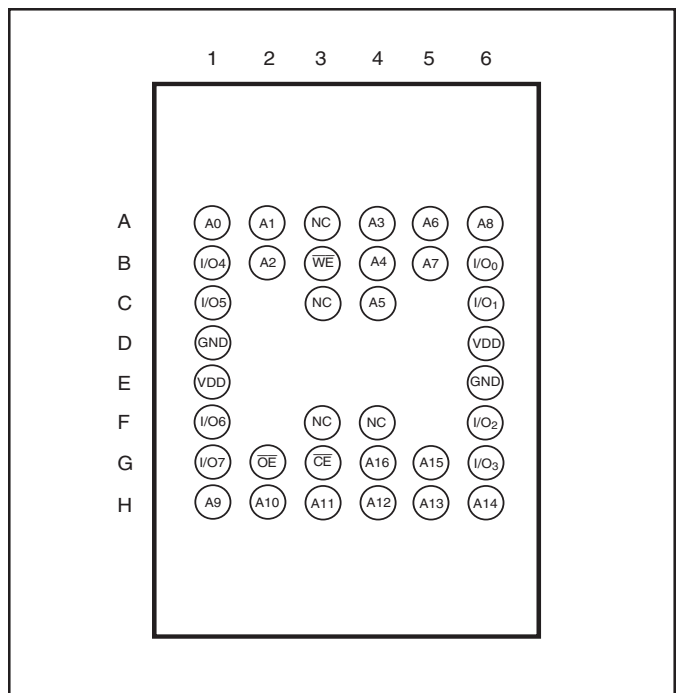

**TRUTH TABLE**

Mode	$\overline{WE}$	$\overline{CE}$	$\overline{OE}$	I/O Operation	V <sub>DD</sub> Current
Not Selected (Power-down)	X	H	X	High-Z	I <sub>SB1</sub> , I <sub>SB2</sub>
Output Disabled	H	L	H	High-Z	I <sub>CC1</sub> , I <sub>CC2</sub>
Read	H	L	L	D <sub>OUT</sub>	I <sub>CC1</sub> , I <sub>CC2</sub>
Write	L	L	X	D <sub>IN</sub>	I <sub>CC1</sub> , I <sub>CC2</sub>

**ABSOLUTE MAXIMUM RATINGS<sup>(1)</sup>**

Symbol	Parameter	Value	Unit
V <sub>TERM</sub>	Terminal Voltage with Respect to GND	-0.5 to V <sub>DD</sub> + 0.5	V
T <sub>STG</sub>	Storage Temperature	-65 to +150	°C
P <sub>T</sub>	Power Dissipation	1.0	W

**Notes:**

1. Stress greater than those listed under ABSOLUTE MAXIMUM RATINGS may cause permanent damage to the device. This is a stress rating only and functional operation of the device at these or any other conditions above those indicated in the operational sections of this specification is not implied. Exposure to absolute maximum rating conditions for extended periods may affect reliability.

**OPERATING RANGE**

Range	Ambient Temperature	V <sub>DD</sub>
Commercial	0°C to +70°C	3.3V ± 0.3V
Industrial	-40°C to +85°C	3.3V ± 0.15V

**DC ELECTRICAL CHARACTERISTICS** (Over Operating Range)

Symbol	Parameter	Test Conditions	Min.	Max.	Unit
V <sub>OH</sub>	Output HIGH Voltage	V <sub>DD</sub> = Min., I <sub>OH</sub> = -4.0 mA	2.4	—	V
V <sub>OL</sub>	Output LOW Voltage	V <sub>DD</sub> = Min., I <sub>OL</sub> = 8.0 mA	—	0.4	V
V <sub>IH</sub>	Input HIGH Voltage		2.2	V <sub>DD</sub> + 0.3	V
V <sub>IL</sub>	Input LOW Voltage <sup>(1)</sup>		-0.3	0.8	V
I <sub>LI</sub>	Input Leakage	GND ≤ V <sub>IN</sub> ≤ V <sub>DD</sub>	Com. Ind.	-1 5	1 5 μA
I <sub>LO</sub>	Output Leakage	GND ≤ V <sub>OUT</sub> ≤ V <sub>DD</sub> , Outputs Disabled	Com. Ind.	-1 -5	1 5 μA

**Notes:**

1. V<sub>IL</sub> = -3.0V for pulse width less than 10 ns.

**IS63LV1024 POWER SUPPLY CHARACTERISTICS<sup>(1)</sup>** (Over Operating Range)

Symbol	Parameter	Test Conditions		-8 ns		-10 ns		-12 ns		Unit
				Min.	Max.	Min.	Max.	Min.	Max.	
I <sub>CC1</sub>	V <sub>DD</sub> Operating Supply Current	V <sub>DD</sub> = Max., $\overline{CE} = V_{IL}$ I <sub>OUT</sub> = 0 mA, f = Max.	Com.	—	160	—	150	—	130	mA
			Ind.	—	170	—	160	—	140	
			typ. <sup>(2)</sup>	—	105	—	95	—	75	
			Ind. (@ 15 ns)					—	90	
I <sub>SB</sub>	TTL Standby Current (TTL Inputs)	V <sub>DD</sub> = Max., V <sub>IN</sub> = V <sub>IH</sub> or V <sub>IL</sub> $\overline{CE} \geq V_{IH}$ , f = Max	Com.	—	55	—	45	—	40	mA
			Ind.	—	55	—	45	—	40	
I <sub>SB1</sub>	TTL Standby Current (TTL Inputs)	V <sub>DD</sub> = Max., V <sub>IN</sub> = V <sub>IH</sub> or V <sub>IL</sub> $\overline{CE} \geq V_{IH}$ , f = 0	Com.	—	25	—	25	—	25	mA
			Ind.	—	30	—	30	—	30	
I <sub>SB2</sub>	CMOS Standby Current (CMOS Inputs)	V <sub>DD</sub> = Max., $\overline{CE} \geq V_{DD} - 0.2V$ , V <sub>IN</sub> ≥ V <sub>DD</sub> - 0.2V, or V <sub>IN</sub> ≤ 0.2V, f = 0	Com.	—	5	—	5	—	5	mA
			Ind.	—	10	—	10	—	10	
			typ. <sup>(2)</sup>	—	0.5	—	0.5	—	0.5	

**Notes:**

- At f = f<sub>MAX</sub>, address and data inputs are cycling at the maximum frequency, f = 0 means no input lines change.
- Typical values are measured at V<sub>DD</sub> = 3.3V, T<sub>A</sub> = 25°C. Not 100% tested.

**IS63LV1024L POWER SUPPLY CHARACTERISTICS<sup>(1)</sup>** (Over Operating Range)

Symbol	Parameter	Test Conditions		-8 ns		-10 ns		-12 ns		Unit
				Min.	Max.	Min.	Max.	Min.	Max.	
I <sub>CC1</sub>	V <sub>DD</sub> Operating Supply Current	V <sub>DD</sub> = Max., $\overline{CE} = V_{IL}$ I <sub>OUT</sub> = 0 mA, f = Max.	Com.	—	100	—	95	—	90	mA
			Ind.	—	110	—	105	—	100	
			typ. <sup>(2)</sup>	—	75	—	70	—	65	
I <sub>SB</sub>	TTL Standby Current (TTL Inputs)	V <sub>DD</sub> = Max., V <sub>IN</sub> = V <sub>IH</sub> or V <sub>IL</sub> $\overline{CE} \geq V_{IH}$ , f = Max	Com.	—	35	—	30	—	25	mA
			Ind.	—	40	—	35	—	30	
I <sub>SB1</sub>	TTL Standby Current (TTL Inputs)	V <sub>DD</sub> = Max., V <sub>IN</sub> = V <sub>IH</sub> or V <sub>IL</sub> $\overline{CE} \geq V_{IH}$ , f = 0	Com.	—	15	—	15	—	15	mA
			Ind.	—	20	—	20	—	20	
I <sub>SB2</sub>	CMOS Standby Current (CMOS Inputs)	V <sub>DD</sub> = Max., $\overline{CE} \geq V_{DD} - 0.2V$ , V <sub>IN</sub> ≥ V <sub>DD</sub> - 0.2V, or V <sub>IN</sub> ≤ 0.2V, f = 0	Com.	—	1	—	1	—	1	mA
			Ind.	—	1.5	—	1.5	—	1.5	
			typ. <sup>(2)</sup>	—	0.05	—	0.05	—	0.05	

**Notes:**

- At f = f<sub>MAX</sub>, address and data inputs are cycling at the maximum frequency, f = 0 means no input lines change.
- Typical values are measured at V<sub>DD</sub> = 3.3V, T<sub>A</sub> = 25°C. Not 100% tested.

**CAPACITANCE<sup>(1,2)</sup>**

Symbol	Parameter	Conditions	Max.	Unit
C <sub>IN</sub>	Input Capacitance	V <sub>IN</sub> = 0V	6	pF
C <sub>I/O</sub>	Input/Output Capacitance	V <sub>OUT</sub> = 0V	8	pF

**Notes:**

- Tested initially and after any design or process changes that may affect these parameters.
- Test conditions: T<sub>A</sub> = 25°C, f = 1 MHz, V<sub>DD</sub> = 3.3V.

**READ CYCLE SWITCHING CHARACTERISTICS<sup>(1)</sup>** (Over Operating Range)

Symbol	Parameter	-8 ns		-10 ns		-12 ns		Unit
		Min.	Max.	Min.	Max.	Min.	Max.	
t <sub>RC</sub>	Read Cycle Time	8	—	10	—	12	—	ns
t <sub>AA</sub>	Address Access Time	—	8	—	10	—	12	ns
t <sub>OH</sub>	Output Hold Time	2	—	2	—	2	—	ns
t <sub>ACE</sub>	$\overline{\text{CE}}$ Access Time	—	8	—	10	—	12	ns
t <sub>DOE</sub>	$\overline{\text{OE}}$ Access Time	—	4	—	5	—	6	ns
t <sub>LZOE<sup>(2)</sup></sub>	$\overline{\text{OE}}$ to Low-Z Output	0	—	0	—	0	—	ns
t <sub>HZOE<sup>(2)</sup></sub>	$\overline{\text{OE}}$ to High-Z Output	0	4	0	5	0	6	ns
t <sub>LZCE<sup>(2)</sup></sub>	$\overline{\text{CE}}$ to Low-Z Output	3	—	3	—	3	—	ns
t <sub>HZCE<sup>(2)</sup></sub>	$\overline{\text{CE}}$ to High-Z Output	0	4	0	5	0	6	ns
t <sub>PU</sub>	$\overline{\text{CE}}$ to Power Up Time	0	—	0	—	0	—	ns
t <sub>PD</sub>	$\overline{\text{CE}}$ to Power Down Time	—	8	—	10	—	12	ns

**Notes:**

1. Test conditions assume signal transition times of 3 ns or less, timing reference levels of 1.5V, input pulse levels of 0 to 3.0V loading specified in Figure 1.
2. Tested with the loading specified in Figure 2. Transition is measured ±500 mV from steady-state voltage. Not 100% tested.

**AC TEST CONDITIONS**

Parameter	Unit
Input Pulse Level	0V to 3.0V
Input Rise and Fall Times	3 ns
Input and Output Timing and Reference Levels	1.5V
Output Load	See Figures 1 and 2

**AC TEST LOADS**

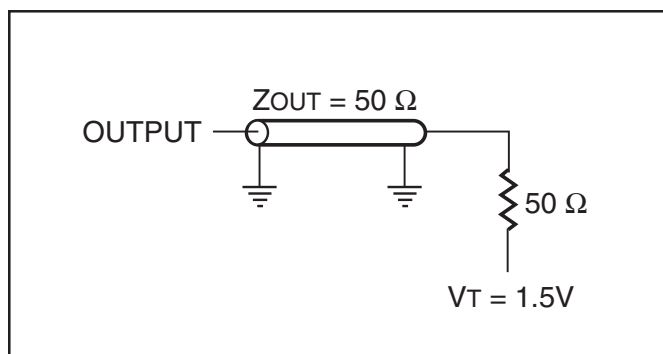

Figure 1

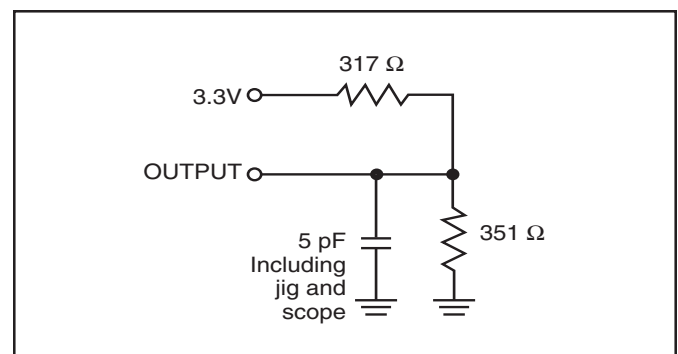
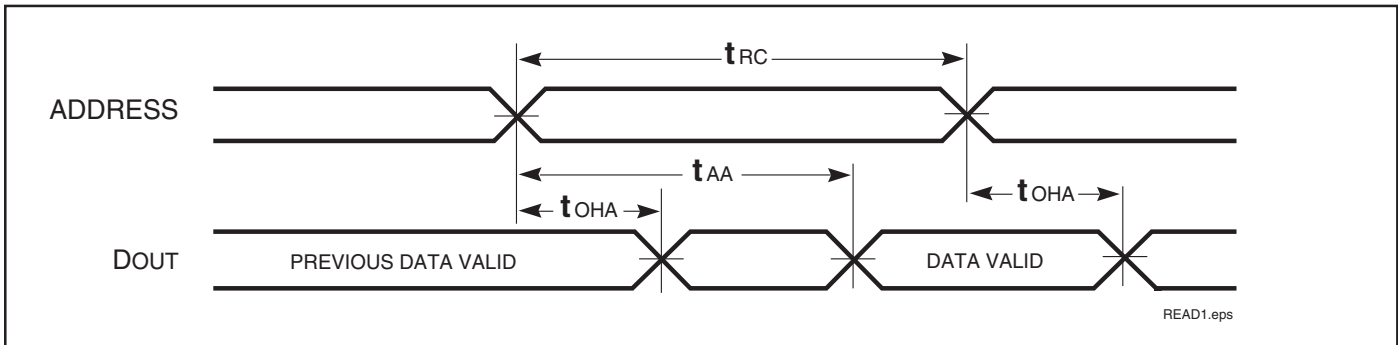

Figure 2

AC WAVEFORMS

READ CYCLE NO. 1<sup>(1,2)</sup>



READ CYCLE NO. 2<sup>(1,3)</sup>

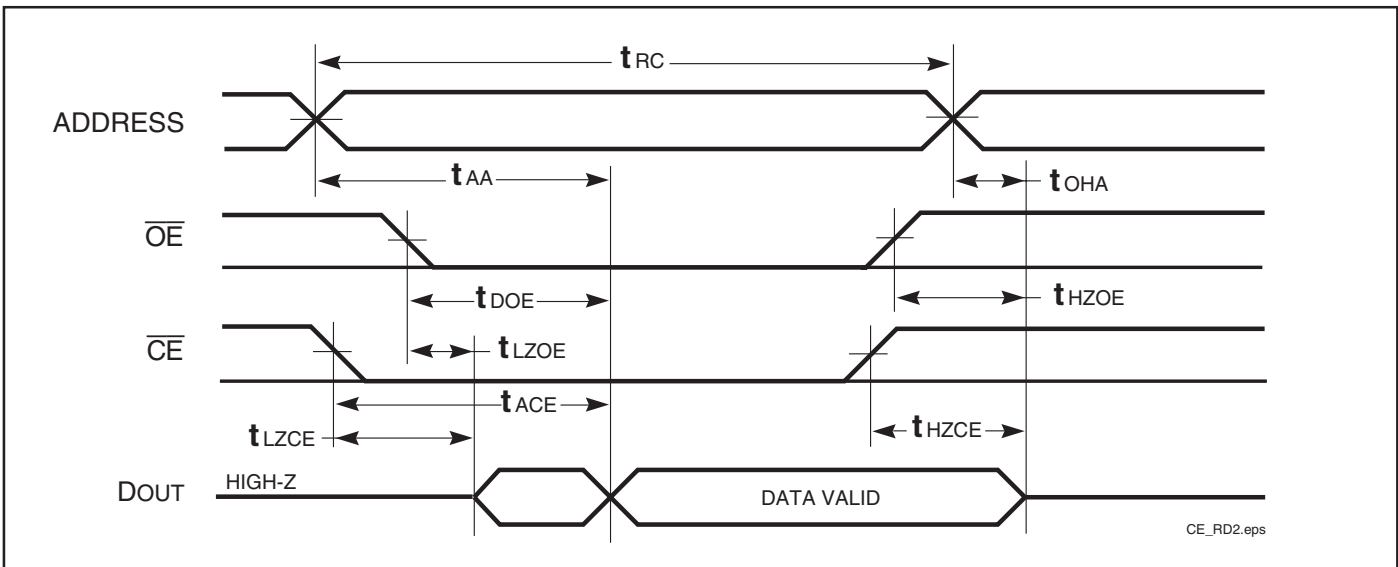

Notes:

1.  $\overline{WE}$  is HIGH for a Read Cycle.
2. The device is continuously selected.  $\overline{OE}$ ,  $\overline{CE}$  =  $V_{IL}$ .
3. Address is valid prior to or coincident with  $\overline{CE}$  LOW transitions.

**WRITE CYCLE SWITCHING CHARACTERISTICS<sup>(1,3)</sup>** (Over Operating Range)

Symbol	Parameter	-8 ns		-10 ns		-12 ns		Unit
		Min.	Max.	Min.	Max.	Min.	Max.	
t <sub>WC</sub>	Write Cycle Time	8	—	10	—	12	—	ns
t <sub>SCE</sub>	$\overline{CE}$ to Write End	7	—	7	—	8	—	ns
t <sub>AW</sub>	Address Setup Time to Write End	8	—	8	—	8	—	ns
t <sub>HA</sub>	Address Hold from Write End	0	—	0	—	0	—	ns
t <sub>SA</sub>	Address Setup Time	0	—	0	—	0	—	ns
t <sub>PWE1</sub> <sup>(1)</sup>	$\overline{WE}$ Pulse Width ( $\overline{OE}$ High)	7	—	7	—	8	—	ns
t <sub>PWE2</sub> <sup>(2)</sup>	$\overline{WE}$ Pulse Width ( $\overline{OE}$ Low)	8	—	10	—	12	—	ns
t <sub>SD</sub>	Data Setup to Write End	5	—	5	—	6	—	ns
t <sub>HD</sub>	Data Hold from Write End	0	—	0	—	0	—	ns
t <sub>HZWE</sub> <sup>(2)</sup>	$\overline{WE}$ LOW to High-Z Output	—	4	—	5	—	6	ns
t <sub>LZWE</sub> <sup>(2)</sup>	$\overline{WE}$ HIGH to Low-Z Output	3	—	3	—	3	—	ns

**Notes:**

1. Test conditions assume signal transition times of 3ns or less, timing reference levels of 1.5V, input pulse levels of 0 to 3.0V and output loading specified in Figure 1.
2. Tested with the load in Figure 2. Transition is measured  $\pm 500$  mV from steady-state voltage. Not 100% tested.
3. The internal write time is defined by the overlap of  $\overline{CE}$  LOW and  $\overline{WE}$  LOW. All signals must be in valid states to initiate a Write, but any one can go inactive to terminate the Write. The Data Input Setup and Hold timing are referenced to the rising or falling edge of the signal that terminates the Write.

**AC WAVEFORMS**

**WRITE CYCLE NO. 1<sup>(1,2)</sup>** ( $\overline{CE}$  Controlled,  $\overline{OE}$  = HIGH or LOW)

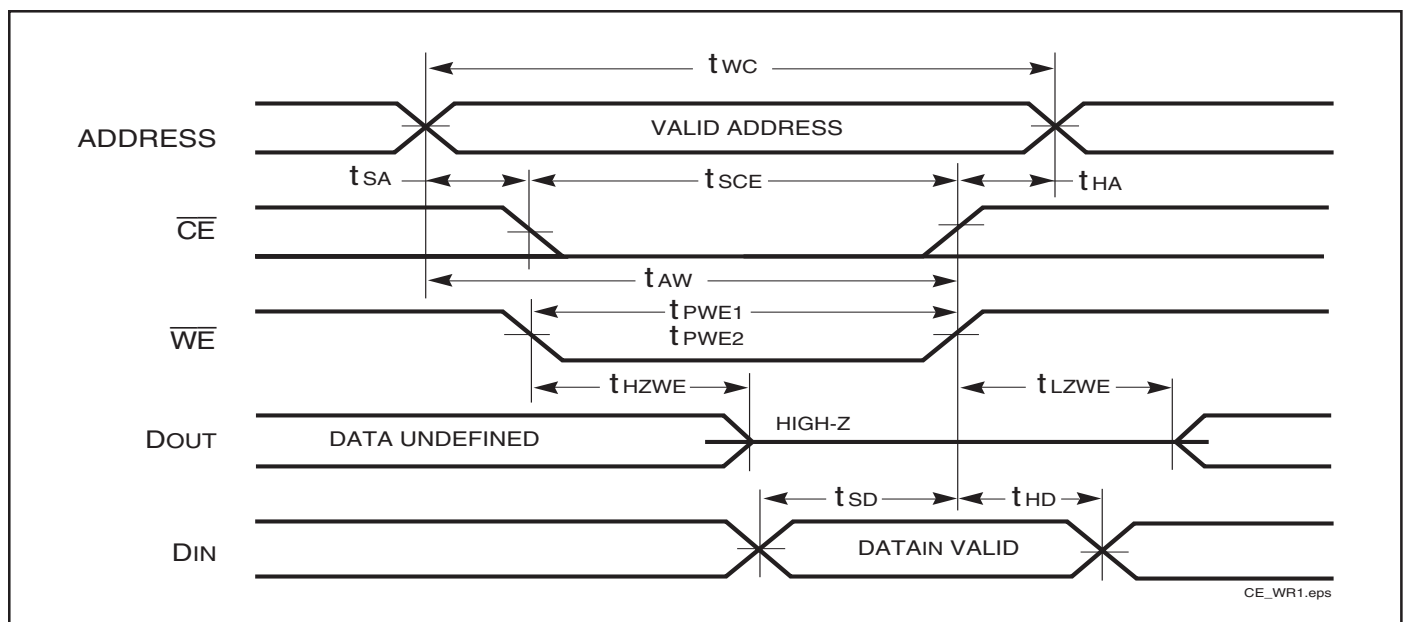

AC WAVEFORMS

WRITE CYCLE NO. 2<sup>(1)</sup> ( $\overline{WE}$  Controlled,  $\overline{OE}$  = HIGH during Write Cycle)

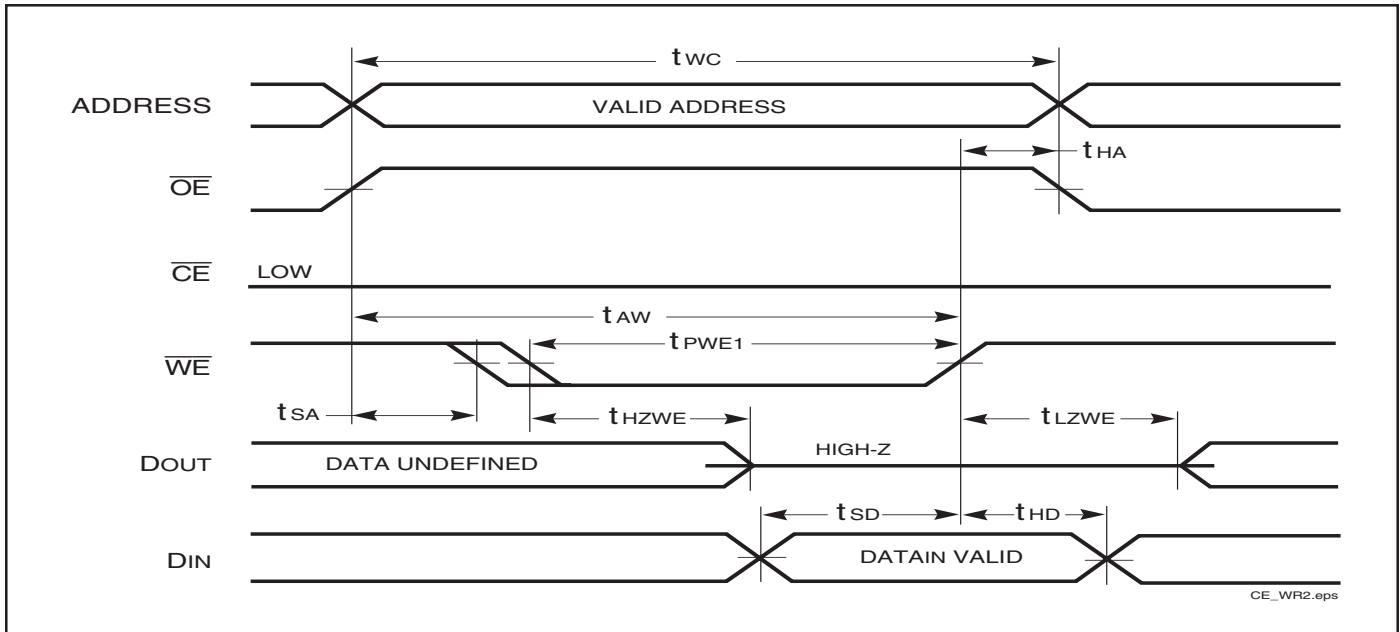

WRITE CYCLE NO. 3 ( $\overline{WE}$  Controlled:  $\overline{OE}$  is LOW During Write Cycle)

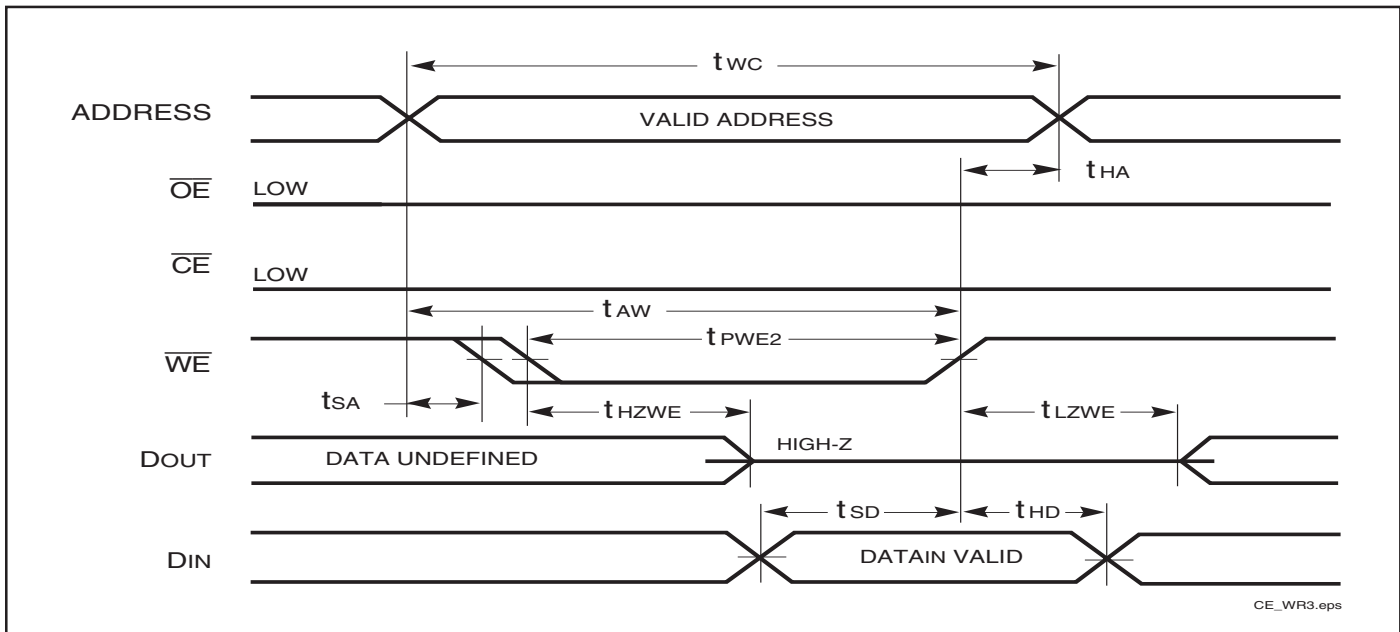

Notes:

1. The internal write time is defined by the overlap of  $\overline{CE}$  LOW and  $\overline{WE}$  LOW. All signals must be in valid states to initiate a Write, but any one can go inactive to terminate the Write. The Data Input Setup and Hold timing are referenced to the rising or falling edge of the signal that terminates the Write.
2. I/O will assume the High-Z state if  $\overline{OE} > V_{IH}$ .



### DATA RETENTION SWITCHING CHARACTERISTICS

Symbol	Parameter	Test Condition	Options	Min.	Typ. <sup>(1)</sup>	Max.	Unit
V <sub>DR</sub>	V <sub>DD</sub> for Data Retention	See Data Retention Waveform		2.0	—	3.6	V
I <sub>DR</sub>	Data Retention Current	V <sub>DD</sub> = 2.0V, $\overline{CE} \geq V_{DD} - 0.2V$	IS63LV1024 IS63LV1024L	—	0.5 0.05	10 1.5	mA
t <sub>SDR</sub>	Data Retention Setup Time	See Data Retention Waveform		0	—	—	ns
t <sub>RDR</sub>	Recovery Time	See Data Retention Waveform		t <sub>RC</sub>	—	—	ns

**Note 1:** Typical values are measured at V<sub>DD</sub> = 3.0V, T<sub>A</sub> = 25°C and not 100% tested.

### DATA RETENTION WAVEFORM ( $\overline{CE}$ Controlled)

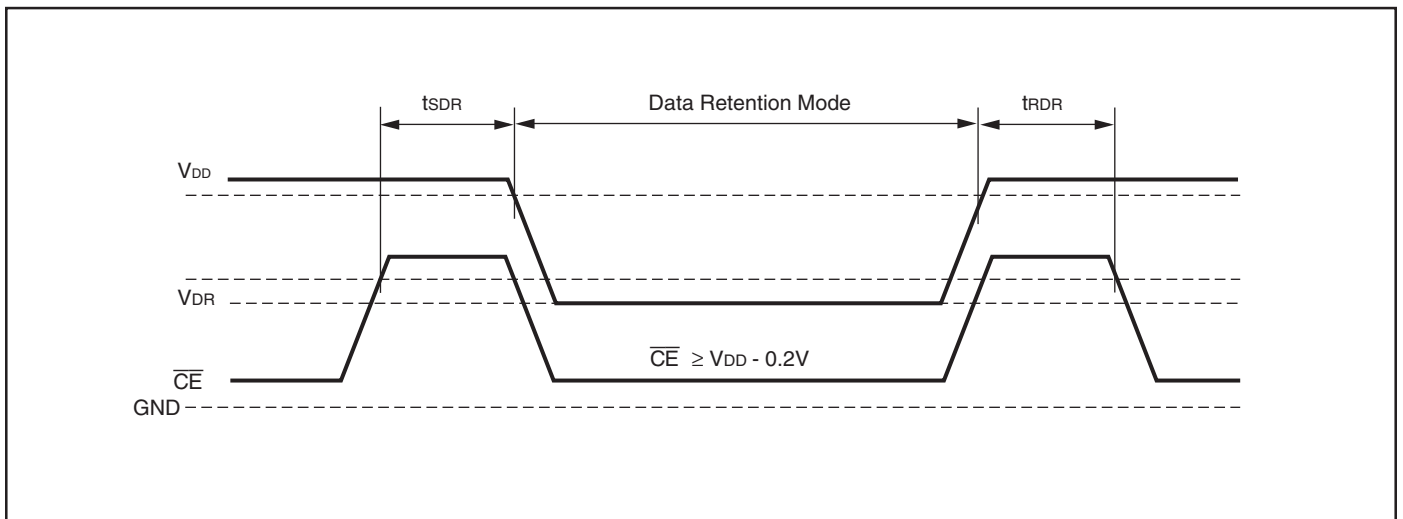

**IS63LV1024 ORDERING INFORMATION**

**Commercial Range: 0°C to +70°C**

Speed (ns)	Order Part No.	Package
8	IS63LV1024-8K	400-mil Plastic SOJ
	IS63LV1024-8KL	400-mil Plastic SOJ, Lead-free
10	IS63LV1024-10T	TSOP (Type II)
	IS63LV1024-10J	300-mil Plastic SOJ
	IS63LV1024-10K	400-mil Plastic SOJ
12	IS63LV1024-12T	TSOP (Type II)
	IS63LV1024-12J	300-mil Plastic SOJ
	IS63LV1024-12KL	400-mil Plastic SOJ, Lead-free

**Industrial Range: -40°C to +85°C**

Speed (ns)	Order Part No.	Package
8	IS63LV1024-8KI	400-mil Plastic SOJ
10	IS63LV1024-10KI	400-mil Plastic SOJ
12	IS63LV1024-12TI	TSOP (Type II)

**IS63LV1024L ORDERING INFORMATION**

**Commercial Range: 0°C to +70°C**

<b>Speed (ns)</b>	<b>Order Part No.</b>	<b>Package</b>
8	IS63LV1024L-8T	TSOP (Type II)
	IS63LV1024L-8B	mBGA (8mmx10mm)
10	IS63LV1024L-10T	TSOP (Type II)
	IS63LV1024L-10TL	TSOP (Type II), Lead-free
	IS63LV1024L-10HL	sTSOP (Type I) (8mm x13.4mm), Lead-free
12	IS63LV1024L-12T	TSOP (Type II)
	IS63LV1024L-12H	sTSOP (Type I) (8mm x13.4mm)
	IS63LV1024L-12J	300-mil Plastic SOJ
	IS63LV1024L-12JL	300-mil Plastic SOJ, Lead-free
	IS63LV1024L-12B	mBGA (8mmx10mm)

**Industrial Range: -40°C to +85°C**

<b>Speed (ns)</b>	<b>Order Part No.</b>	<b>Package</b>
8	IS63LV1024L-8TI	TSOP (Type II)
	IS63LV1024L-8JI	300-mil Plastic SOJ
	IS63LV1024L-8KI	400-mil Plastic SOJ
	IS63LV1024L-8BI	mBGA (8mmx10mm)
10	IS63LV1024L-10HI	sTSOP (Type I) (8mm x13.4mm)
	IS63LV1024L-10JLI	300-mil Plastic SOJ, Lead-free
	IS63LV1024L-10KLI	400-mil Plastic SOJ, Lead-free
	IS63LV1024L-10TLI	TSOP (Type II), Lead-free
12	IS63LV1024L-12BI	mBGA (8mmx10mm)
	IS63LV1024L-12BLI	mBGA (8mmx10mm), Lead-free

# PACKAGING INFORMATION

400-mil Plastic SOJ

Package Code: K

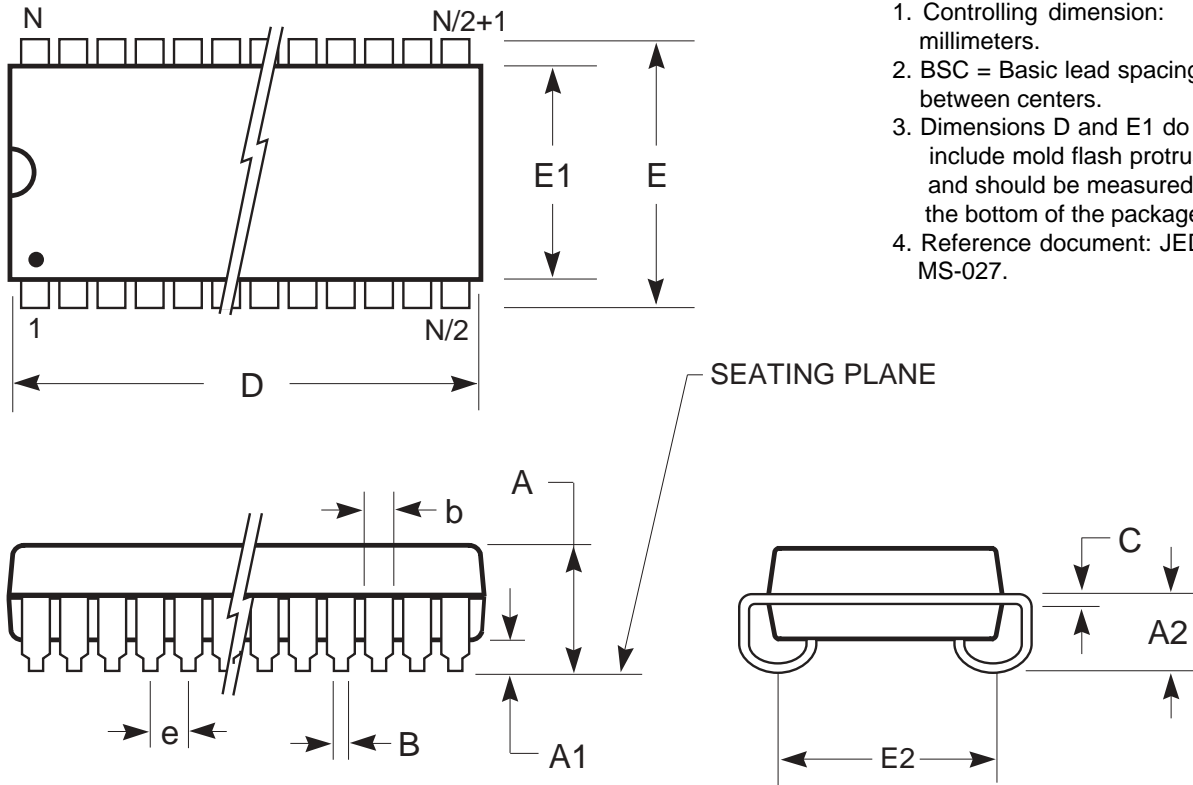

**Notes:**

1. Controlling dimension: millimeters.
2. BSC = Basic lead spacing between centers.
3. Dimensions D and E1 do not include mold flash protrusions and should be measured from the bottom of the package.
4. Reference document: JEDEC MS-027.

Symbol	Millimeters		Inches		Millimeters		Inches		Millimeters		Inches	
	Min	Max	Min	Max	Min	Max	Min	Max	Min	Max	Min	Max
No. Leads (N)	28				32				36			
A	3.25	3.75	0.128	0.148	3.25	3.75	0.128	0.148	3.25	3.75	0.128	0.148
A1	0.64	—	0.025	—	0.64	—	0.025	—	0.64	—	0.025	—
A2	2.08	—	0.082	—	2.08	—	0.082	—	2.08	—	0.082	—
B	0.38	0.51	0.015	0.020	0.38	0.51	0.015	0.020	0.38	0.51	0.015	0.020
b	0.66	0.81	0.026	0.032	0.66	0.81	0.026	0.032	0.66	0.81	0.026	0.032
C	0.18	0.33	0.007	0.013	0.18	0.33	0.007	0.013	0.18	0.33	0.007	0.013
D	18.29	18.54	0.720	0.730	20.82	21.08	0.820	0.830	23.37	23.62	0.920	0.930
E	11.05	11.30	0.435	0.445	11.05	11.30	0.435	0.445	11.05	11.30	0.435	0.445
E1	10.03	10.29	0.395	0.405	10.03	10.29	0.395	0.405	10.03	10.29	0.395	0.405
E2	9.40 BSC		0.370 BSC		9.40 BSC		0.370 BSC		9.40 BSC		0.370 BSC	
e	1.27 BSC		0.050 BSC		1.27 BSC		0.050 BSC		1.27 BSC		0.050 BSC	

Copyright © 2003 Integrated Silicon Solution, Inc. All rights reserved. ISSI reserves the right to make changes to this specification and its products at any time without notice. ISSI assumes no liability arising out of the application or use of any information, products or services described herein. Customers are advised to obtain the latest version of this device specification before relying on any published information and before placing orders for products.

Symbol	Millimeters		Inches		Millimeters		Inches		Millimeters		Inches	
	Min	Max	Min	Max	Min	Max	Min	Max	Min	Max	Min	Max
No. Leads (N)	<b>40</b>				<b>42</b>				<b>44</b>			
A	3.25	3.75	0.128	0.148	3.25	3.75	0.128	0.148	3.25	3.75	0.128	0.148
A1	0.64	—	0.025	—	0.64	—	0.025	—	0.64	—	0.025	—
A2	2.08	—	0.082	—	2.08	—	0.082	—	2.08	—	0.082	—
B	0.38	0.51	0.015	0.020	0.38	0.51	0.015	0.020	0.38	0.51	0.015	0.020
b	0.66	0.81	0.026	0.032	0.66	0.81	0.026	0.032	0.66	0.81	0.026	0.032
C	0.18	0.33	0.007	0.013	0.18	0.33	0.007	0.013	0.18	0.33	0.007	0.013
D	25.91	26.16	1.020	1.030	27.18	27.43	1.070	1.080	28.45	28.70	1.120	1.130
E	11.05	11.30	0.435	0.445	11.05	11.30	0.435	0.445	11.05	11.30	0.435	0.445
E1	10.03	10.29	0.395	0.405	10.03	10.29	0.395	0.405	10.03	10.29	0.395	0.405
E2	9.40 BSC		0.370 BSC		9.40 BSC		0.370 BSC		9.40 BSC		0.370 BSC	
e	1.27 BSC		0.050 BSC		1.27 BSC		0.050 BSC		1.27 BSC		0.050 BSC	

Copyright © 2003 Integrated Silicon Solution, Inc. All rights reserved. ISSI reserves the right to make changes to this specification and its products at any time without notice. ISSI assumes no liability arising out of the application or use of any information, products or services described herein. Customers are advised to obtain the latest version of this device specification before relying on any published information and before placing orders for products.

# PACKAGING INFORMATION



## 300-mil Plastic SOJ

Package Code: J

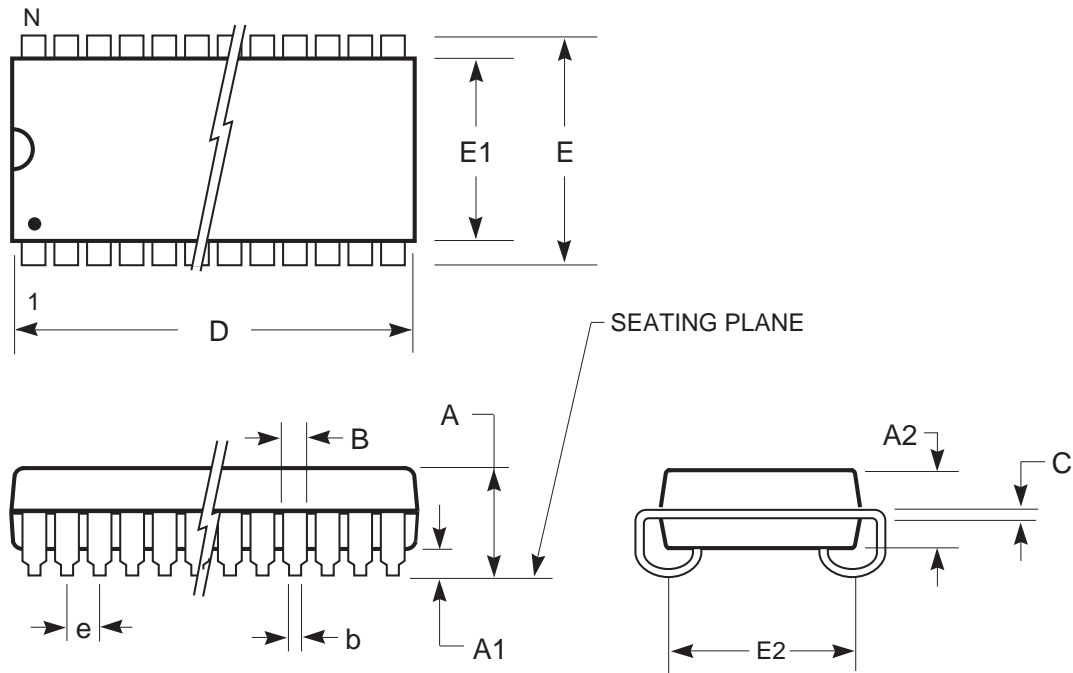

Sym.	MILLIMETERS			INCHES		
	Min.	Typ.	Max.	Min.	Typ.	Max.
N0. Leads	24/26					
A	—	—	3.56	—	—	0.140
A1	0.64	—	—	0.025	—	—
A2	2.41	—	2.67	0.095	—	0.105
b	0.41	—	0.51	0.016	—	0.020
B	0.66	—	0.81	0.026	—	0.032
C	0.20	—	0.25	0.008	—	0.010
D	17.02	—	17.27	0.670	—	0.680
E	8.26	—	8.76	0.325	—	0.345
E1	7.49	—	7.75	0.295	—	0.305
E2	6.27	—	7.29	0.247	—	0.287
e	1.27 BSC			0.050 BSC		

### Notes:

1. Controlling dimension: inches, unless otherwise specified.
2. BSC = Basic lead spacing between centers.
3. Dimensions D and E1 do not include mold flash protrusions and should be measured from the bottom of the package.
4. Formed leads shall be planar with respect to one another within 0.004 inches at the seating plane.

Copyright © 2003 Integrated Silicon Solution, Inc. All rights reserved. ISSI reserves the right to make changes to this specification and its products at any time without notice. ISSI assumes no liability arising out of the application or use of any information, products or services described herein. Customers are advised to obtain the latest version of this device specification before relying on any published information and before placing orders for products.

# PACKAGING INFORMATION



300-mil Plastic SOJ  
Package Code: J

MILLIMETERS				INCHES		
Sym.	Min.	Typ.	Max.	Min.	Typ.	Max.
NO. Leads				28		
A	—	—	3.56	—	—	0.140
A1	0.64	—	—	0.025	—	—
A2	2.41	—	2.67	0.095	—	0.105
b	0.41	—	0.51	0.016	—	0.020
B	0.66	—	0.81	0.026	—	0.032
C	0.20	—	0.25	0.008	—	0.010
D	18.29	—	18.54	0.720	—	0.730
E	8.26	—	8.76	0.325	—	0.345
E1	7.49	—	7.75	0.295	—	0.305
E2	6.27	—	7.29	0.247	—	0.287
e	1.27 BSC			0.050 BSC		

MILLIMETERS				INCHES		
Sym.	Min.	Typ.	Max.	Min.	Typ.	Max.
NO. Leads				32		
A	—	—	3.56	—	—	0.140
A1	0.64	—	—	0.025	—	—
A2	2.41	—	2.67	0.095	—	0.105
b	0.41	—	0.51	0.016	—	0.020
B	0.66	—	0.81	0.026	—	0.032
C	0.20	—	0.25	0.008	—	0.010
D	20.83	—	21.08	0.820	—	0.830
E	8.26	—	8.76	0.325	—	0.345
E1	7.49	—	7.75	0.295	—	0.305
E2	6.27	—	7.29	0.247	—	0.287
e	1.27 BSC			0.050 BSC		

# PACKAGING INFORMATION

Plastic STSOP - 32 pins  
 Package Code: H (Type I)

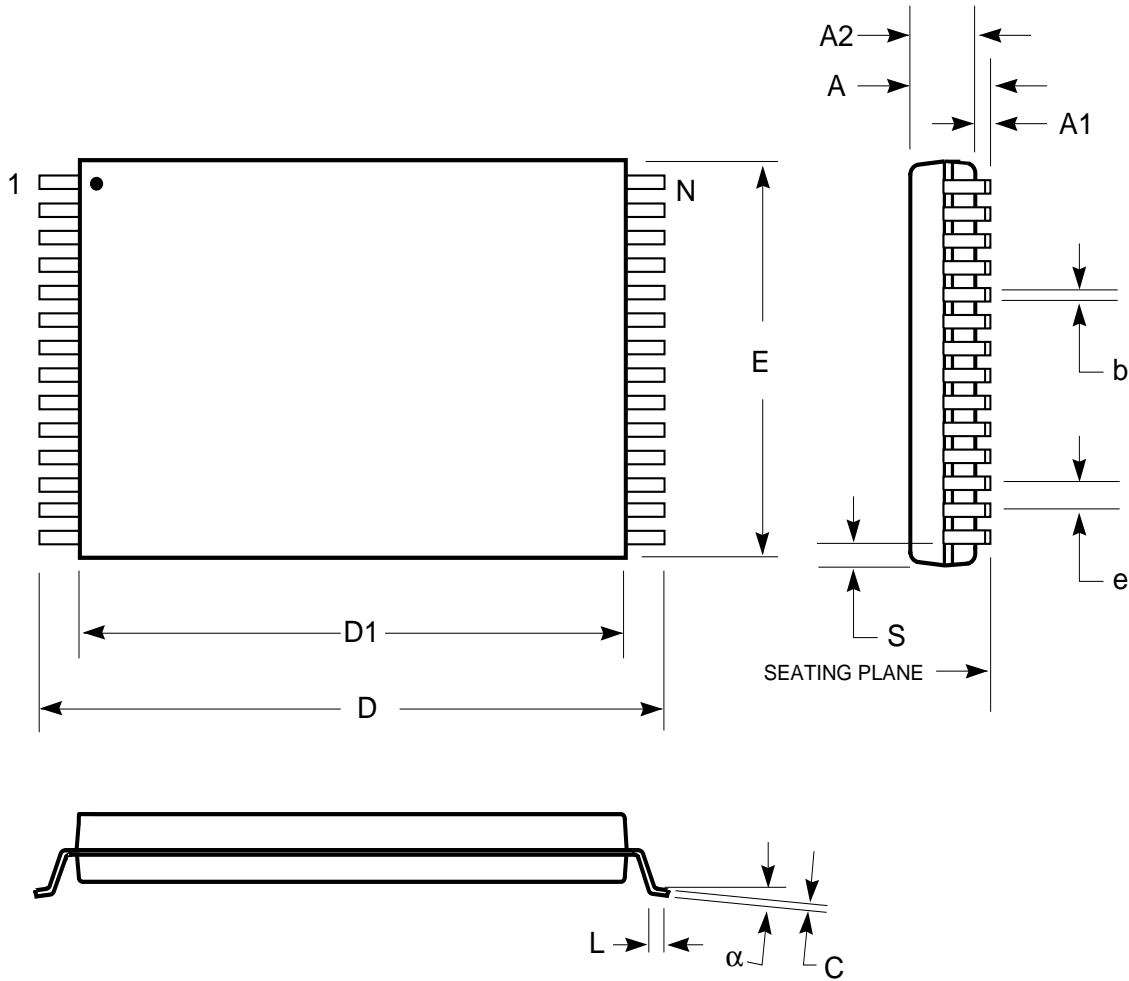

Plastic STSOP (H - Type I)				
	Millimeters		Inches	
Symbol	Min	Max	Min	Max
Ref. Std.				
N	32			
A	—	1.25	—	0.049
A1	0.05	—	0.002	—
A2	0.95	1.05	0.037	0.041
b	0.17	0.23	0.007	0.009
C	0.14	0.16	0.0055	0.0063
D	13.20	13.60	0.520	0.535
D1	11.70	11.90	0.461	0.469
E	7.90	8.10	0.311	0.319
e	0.50 BSC		0.020 BSC	
L	0.30	0.70	0.012	0.028
S	0.28 Typ.		0.011 Typ.	
$\alpha$	0°	5°	0°	5°

**Notes:**

1. Controlling dimension: millimeters, unless otherwise specified.
2. BSC = Basic lead spacing between centers.
3. Dimensions D1 and E do not include mold flash protrusions and should be measured from the bottom of the package.
4. Formed leads shall be planar with respect to one another within 0.004 inches at the seating plane.



# PACKAGING INFORMATION



## Mini Ball Grid Array Package Code: B (36-pin)

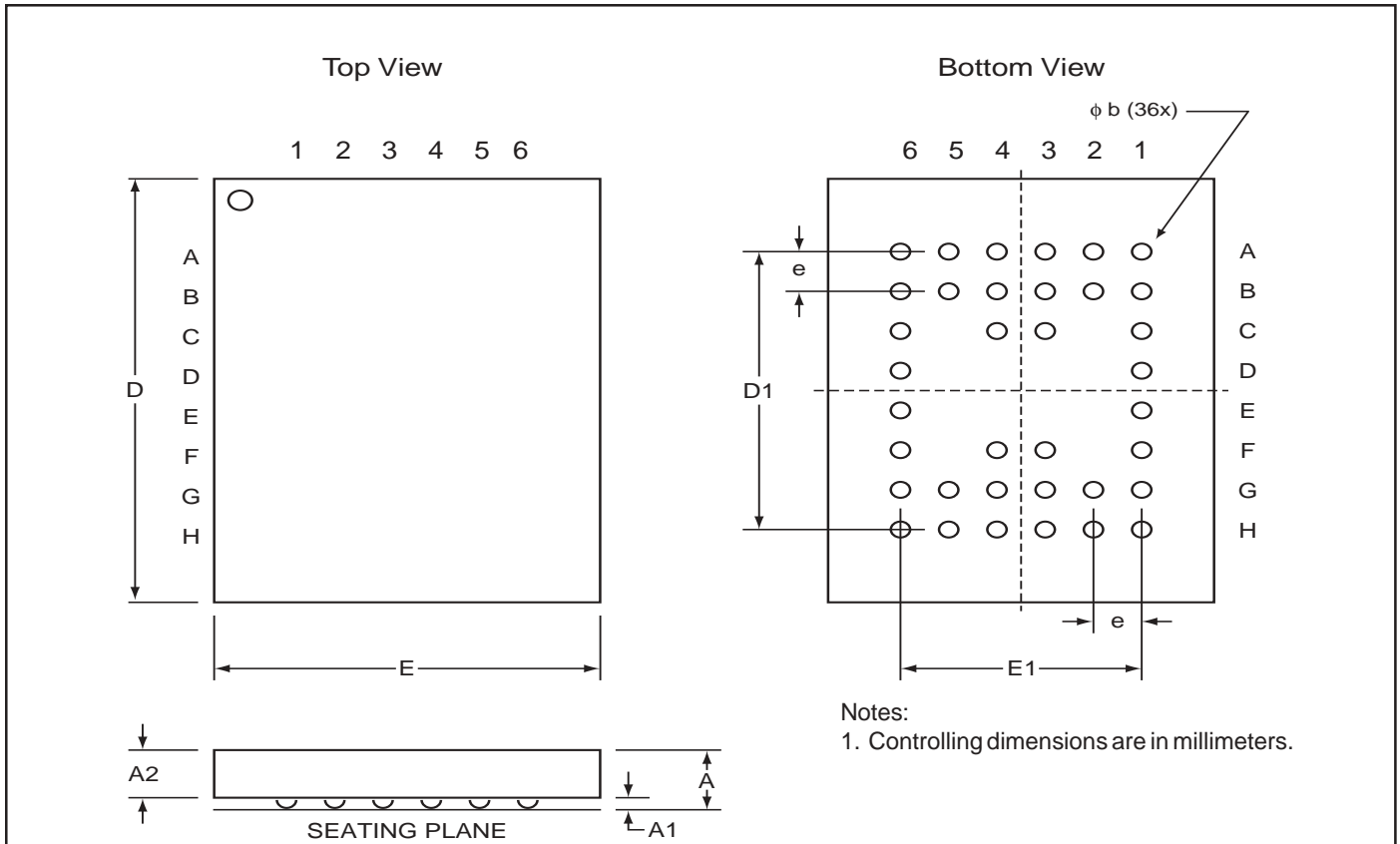

### mBGA - 6mm x 8mm

	MILLIMETERS			INCHES			
	Sym.	Min.	Typ.	Max.	Min.	Typ.	Max.
N0. Leads		36			36		
A	—	—	1.20	—	—	0.047	
A1	0.24	—	0.30	0.009	—	0.012	
A2	0.60	—	—	0.024	—	—	
D	7.90	8.00	8.10	0.311	0.315	0.319	
D1		5.25BSC		0.207BSC			
E	5.90	6.00	6.10	0.232	0.236	0.240	
E1		3.75BSC		0.148BSC			
e		0.75BSC		0.030BSC			
b	0.30	0.35	0.40	0.012	0.014	0.016	

### mBGA - 8mm x 10mm

	MILLIMETER			INCHES			
	Sym.	Min.	Typ.	Max.	Min.	Typ.	Max.
N0. Leads		36			36		
A	—	—	1.20	—	—	0.047	
A1	0.24	—	0.30	0.009	—	0.012	
A2	0.60	—	—	0.024	—	—	
D	9.90	10.00	10.10	0.390	0.394	0.398	
D1		5.25BSC		.207BSC			
E	7.90	8.00	8.10	0.311	0.315	0.319	
E1		3.75BSC		0.148BSC			
e		0.75BSC		0.030BSC			
b	0.30	0.35	0.40	0.012	0.014	0.016	

Copyright © 2003 Integrated Silicon Solution, Inc. All rights reserved. ISSI reserves the right to make changes to this specification and its products at any time without notice. ISSI assumes no liability arising out of the application or use of any information, products or services described herein. Customers are advised to obtain the latest version of this device specification before relying on any published information and before placing orders for products.

Integrated Silicon Solution, Inc. — [www.issi.com](http://www.issi.com) — 1-800-379-4774

Rev. E  
01/15/03

# PACKAGING INFORMATION



## Plastic TSOP Package Code: T (Type II)



### Notes:

1. Controlling dimension: millimeters, unless otherwise specified.
2. BSC = Basic lead spacing between centers.
3. Dimensions D and E1 do not include mold flash protrusions and should be measured from the bottom of the package.
4. Formed leads shall be planar with respect to one another within 0.004 inches at the seating plane.

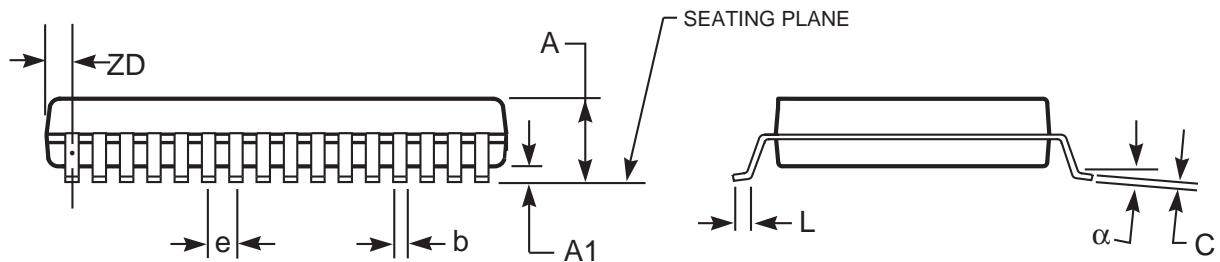

Plastic TSOP (T - Type II)

Symbol	Millimeters		Inches		Millimeters		Inches		Millimeters		Inches	
	Min	Max	Min	Max	Min	Max	Min	Max	Min	Max	Min	Max
Ref. Std.												
No. Leads (N)	32				44				50			
A	—	1.20	—	0.047	—	1.20	—	0.047	—	1.20	—	0.047
A1	0.05	0.15	0.002	0.006	0.05	0.15	0.002	0.006	0.05	0.15	0.002	0.006
b	0.30	0.52	0.012	0.020	0.30	0.45	0.012	0.018	0.30	0.45	0.012	0.018
C	0.12	0.21	0.005	0.008	0.12	0.21	0.005	0.008	0.12	0.21	0.005	0.008
D	20.82	21.08	0.820	0.830	18.31	18.52	0.721	0.729	20.82	21.08	0.820	0.830
E1	10.03	10.29	0.391	0.400	10.03	10.29	0.395	0.405	10.03	10.29	0.395	0.405
E	11.56	11.96	0.451	0.466	11.56	11.96	0.455	0.471	11.56	11.96	0.455	0.471
e	1.27 BSC		0.050 BSC		0.80 BSC		0.032 BSC		0.80 BSC		0.031 BSC	
L	0.40	0.60	0.016	0.024	0.41	0.60	0.016	0.024	0.40	0.60	0.016	0.024
ZD	0.95 REF		0.037 REF		0.81 REF		0.032 REF		0.88 REF		0.035 REF	
alpha	0°	5°	0°	5°	0°	5°	0°	5°	0°	5°	0°	5°

Copyright © 2003 Integrated Silicon Solution, Inc. All rights reserved. ISSI reserves the right to make changes to this specification and its products at any time without notice. ISSI assumes no liability arising out of the application or use of any information, products or services described herein. Customers are advised to obtain the latest version of this device specification before relying on any published information and before placing orders for products.