

ISO422

DIFFERENTIAL BUS TRANSCEIVER

FEATURES

- FULL-/HALF-DUPLEX OPERATION
- 1500Vrms ISOLATION (cont)
- 2500Vrms ISOLATION (1 min)
- 2.5Mbps PERFORMANCE
- LOOP-TEST FACILITY

APPLICATIONS

- BUS TRANSMISSION SYSTEMS
- GROUND LOOP ISOLATION

DESCRIPTION

ISO422 provides 1500Vrms isolation for industrial bus transmission systems. ISO422 may be configured in full or half duplex modes providing the user with best flexibility for the application. Transmission rates of 2.5Mbps can be obtained covering most requirements. A loop-back test facility is included. LBE allows data on the D input to be routed to the R output for test purposes.

ISO422 is available in 24-pin PDIP and 24-pin Gull Wing⁽¹⁾ packages and is specified over the temperature range -40°C to +85°C.

NOTE: (1) Gull Wing version available Q1'99.

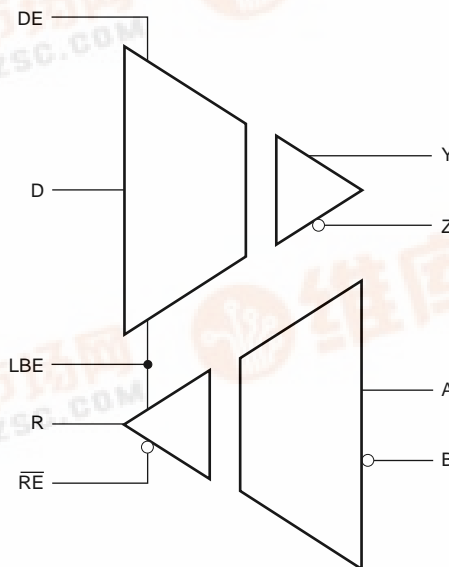

SPECIFICATIONS

At $T_A = +25^\circ\text{C}$, and $V_S = +5\text{V}$, unless otherwise noted.

PARAMETER	CONDITIONS	ISO422P, P-U ⁽¹⁾			UNITS
		MIN	TYP	MAX	
ISOLATION					
Rated Continuous Isolation	V_{ISO} 50Hz, 60Hz	1500			V
Partial Discharge Voltage	1s, 5 x 5pC/per cycle ⁽²⁾	2500			V
Barrier Impedance			$> 10^{14} \parallel 10$		$\Omega \parallel \text{pF}$
Leakage Current	240V, 60Hz		1		μA
	2500V, 50Hz			10	μA
Creepage Distance			8.6		mm
Internal Isolation Distance			0.1		mm
Transient Recovery Time	5kV/ μs Edge			1	μs
DRIVER DC CHARACTERISTICS					
High Level Input Voltage	V_{IH} D and DE Inputs ⁽³⁾	2			V
Low Level Input Voltage	V_{IL} D and DE Inputs ⁽³⁾			0.8	V
Input Leakage Current	I_L D and DE Inputs ⁽³⁾		5		nA
Input Capacitance	C_{IN} D and DE Inputs ⁽³⁾		5		pF
Output Voltage	V_O V_Y or V_Z	0		5	V
Differential Output Voltage	V_{OD} I_{OY} or $I_{OZ} = 0$	1.5		5	V
	$R_L = 100\Omega$	2	3.6	5	V
	$R_L = 54\Omega$	1.5	2.8	5	V
Change in Mag Diff Out Voltage	$\Delta V_{OD} $ $R_L = 100\Omega$ or 54Ω ⁽⁴⁾		± 40	± 200	mV
Common-Mode Output Voltage	V_{OC} $R_L = 100\Omega$ or 54Ω			3	V
Change in Mag CM Out Voltage	$\Delta V_{OC} $ $R_L = 100\Omega$ or 54Ω ⁽⁴⁾		± 40	± 200	mV
Output Current	I_O $V_O = V_{CC2}$, Output Disabled		± 10	± 1000	nA
	$V_O = 0\text{V}$, Output Disabled		± 10	± 1000	nA
Short-Circuit Output Current	$V_O = V_{CC2}$, Continuous		100		mA
	$V_O = 0\text{V}$, Continuous		-110		mA
DRIVER SWITCHING CHARACTERISTICS (Figure 6)					
Differential Output Delay Time	t_{DD} $R_L = 54\Omega$		120	150	ns
Skew $ t_{DDH} - t_{DDL} $	$R_L = 54\Omega$		25	50	ns
Differential Output Transition Time	t_{DT} $R_L = 54\Omega$			100	ns
Output Enable Time to HIGH	t_{DZH} $R_L = 100\Omega$		120	150	ns
Output Enable Time to LOW	t_{DZL} $R_L = 100\Omega$		120	150	ns
Output Disable Time from HIGH	t_{DZH} $R_L = 100\Omega$		120	150	ns
Output Disable Time from LOW	t_{DLZ} $R_L = 100\Omega$		120	150	ns
RECEIVER DC CHARACTERISTICS					
High Level Output Voltage	V_{OH} $I_{OH} = 6\text{mA}$	$V_{CC} - 1$			V
Low Level Output Voltage	V_{OL} $I_{OL} = 6\text{mA}$			0.4	V
Output Short-Circuit Current	I_{OS} 1s max		30		mA
Output HI-Z Leakage	I_{OZ} $V_{OUT} = 0\text{V}$ to V_{CC1}		± 10	± 1000	nA
Enable Input HIGH Threshold	V_{IH} \overline{RE} Input ⁽³⁾	2			V
Enable Input LOW Threshold	V_{IL} \overline{RE} Input ⁽³⁾			0.8	V
Input Leakage Current	I_L \overline{RE} Input ⁽³⁾		5		nA
Input Capacitance	C_{IN} \overline{RE} Input ⁽³⁾		5		pF
Differential Input HIGH Threshold	V_{TH} $V_O = 2.8\text{V}$		100	200	mV
Differential Input LOW Threshold	V_{TL} $V_O = 0.4\text{V}$	-200	-100		mV
Input Hysteresis	See Note 5		60		mV
Line Input Current	I_{BI} Power On ($GND_B < V_{BI} < V_{SB}$)		± 10	± 1000	nA
Line Voltage	V_{BI} Power Off ($I_{BI} \pm 10\text{mA}$ max)		± 12		V
Input Resistance	R_{IN}	1			$M\Omega$
RECEIVER SWITCHING CHARACTERISTICS (Figure 7)					
Propagation Delay L to H	t_{RLH} $V_{ID} = -1.5\text{V}$ to 1.5V , $C_L = 10\text{pF}$		120	150	ns
Propagation Delay H to L	t_{RHL} $V_{ID} = 1.5\text{V}$ to -1.5V , $C_L = 10\text{pF}$		120	150	ns
Skew $ t_{RLH} - t_{RHL} $			40		ns
Output Rise Time	t_R $C_L = 10\text{pF}$		10		ns
Output Fall Time	t_F $C_L = 10\text{pF}$		10		ns
Output Enable Time to HIGH	t_{RZH} $C_L = 10\text{pF}$		15	25	ns
Output Enable Time to LOW	t_{RZL} $C_L = 10\text{pF}$		15	25	ns
Output Disable Time from HIGH	t_{RHZ} $C_L = 10\text{pF}$		15	25	ns
Output Disable Time from LOW	t_{RLZ} $C_L = 10\text{pF}$		15	25	ns

SPECIFICATIONS (CONT)

At $T_A = +25^\circ\text{C}$, and $V_S = +5\text{V}$, unless otherwise noted.

PARAMETER	CONDITIONS	ISO422P, P-U ⁽¹⁾			UNITS
		MIN	TYP	MAX	
POWER					
Supply Voltage—Data Side	V_{SA}	4.5		5.5	V
Supply Current—Data Side	I_{SA}		10	13	mA
Supply Current—Data Side	I_{SA}		20		mA
Supply Voltage—Bus Side	V_{SB}	4.5		5.5	V
Supply Voltage—Bus Side	I_{SB}		12	20	mA
			20		mA
BUS LIMITS					
Input Current				± 10	mA
Maximum Differential Input				± 5	V
Maximum Data Rate			2.5		Mbps
TEMPERATURE RANGE					
Operating		-40		+85	$^\circ\text{C}$
Storage		-40		+125	$^\circ\text{C}$
Thermal Resistance	θ_{JA}		75		$^\circ\text{C/W}$

NOTES: (1) Gull Wing version available Q1'99. (2) All devices receive a 1s test. Failure criterion is > 5 pulses of $> 5\text{pC}$ per cycle. (3) Logic inputs are HCT-type and thresholds are a function of power supply voltage with approximately 100mV hysteresis. (4) Change in magnitude when the input is changed from HIGH to LOW. (5) The difference between the differential low to high and high to low transition points.

PIN CONFIGURATION

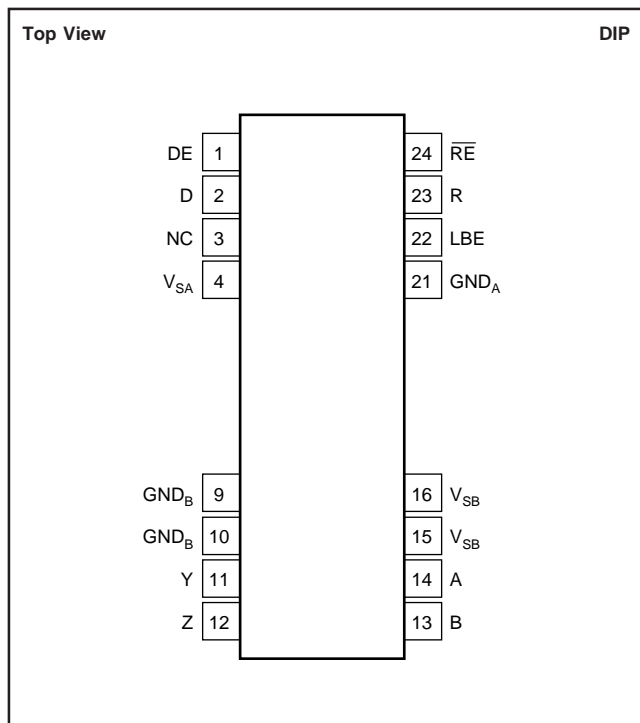

ABSOLUTE MAXIMUM RATINGS

Supply Voltage: V_{SA}	-0.5V to +6V
V_{SB}	-0.5V to +6V
Continuous Isolation Voltage	1500Vrms
Storage Temperature	-40°C to $+125^\circ\text{C}$
Lead Temperature (soldering, 10s)	$+300^\circ\text{C}$

PACKAGE INFORMATION

PRODUCT	PACKAGE	PACKAGE DRAWING NUMBER ⁽¹⁾
ISO422P	24-Pin Plastic DIP	243-4
ISO422P-U	24-Pin Gull Wing Surface Mount	243-5

NOTE: (1) For detailed drawing and dimension table, please see end of data sheet, or Appendix C of Burr-Brown IC Data Book.



ELECTROSTATIC DISCHARGE SENSITIVITY

Electrostatic discharge can cause damage ranging from performance degradation to complete device failure. Burr-Brown Corporation recommends that all integrated circuits be handled and stored using appropriate ESD protection methods.

ESD damage can range from subtle performance degradation to complete device failure. Precision integrated circuits may be more susceptible to damage because very small parametric changes could cause the device not to meet published specifications.

TYPICAL PERFORMANCE CURVES

At $T_A = +25^\circ\text{C}$, and $V_S = +5\text{V}$, unless otherwise noted.

PROPAGATION DELAY

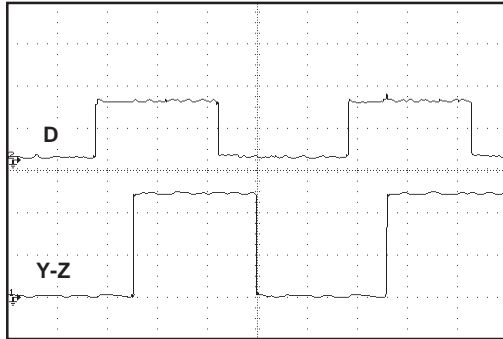

2 $\mu\text{s}/\text{div}$

BUS 0 TO 1 TRANSITION

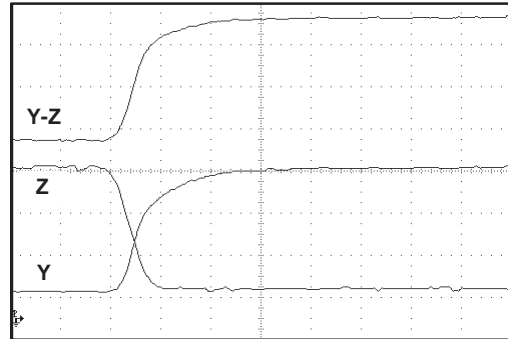

20ns/div

BUS 1 TO 0 TRANSITION

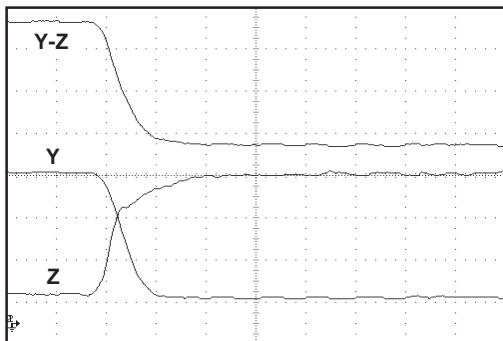

20ns/div

TERMINATED 200m CABLE

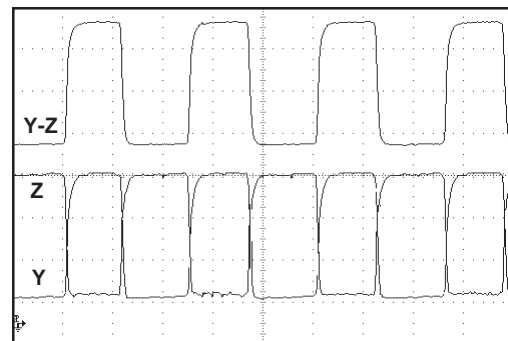

50ns/div

2k Ω RESISTORS INSERTED IN TERMINATED CABLE

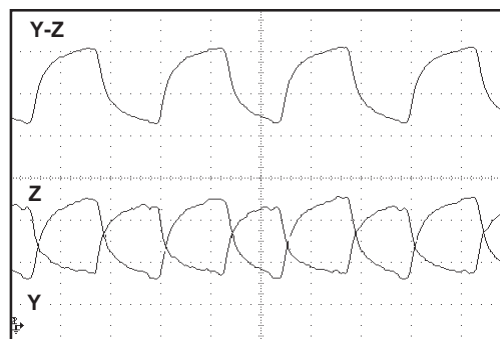

200ns/div

OPERATION

ISO422 is an isolated, full-duplex bus transceiver which is compatible with three-wire data bus systems using EIA standards RS-422-A and RS-485. It is based on Burr-Brown's capacitive barrier technology. The data bus input is designed to present a very high impedance to the data bus, thus allowing a virtually unlimited number of receivers on any data bus section. To allow this feature, the data bus input is limited to a common-mode range within the magnitude of the supplies. This limitation requires that all nodes on the bus are referenced to a common ground. However, systems attached to the bus through ISO422, are isolated up to 1500Vrms and may, therefore, have local floating ground potentials up to this isolation voltage. The circuit encodes all data passed across the barrier to ensure that the input values and control signals are correctly passed across the barrier under all power up conditions. The ISO422 also allows data recovery to the current input state, after any transient upset.

TRANSMIT

Data is passed from the D input to the data bus outputs after a barrier transmission delay (t_{DD}) when the DE input is HIGH. When DE is LOW, the data bus drivers are switched off, and assume the high impedance state. When enabling the data bus output, i.e., switching DE from LOW to HIGH, the enable signal is passed directly across the barrier and enables the output, after a barrier transmission delay and output enable time (t_{DLZ}/t_{DZH}). Similarly, when disabling the data bus output, i.e., switching DE from HIGH to LOW, the disable signal is passed directly across the barrier and disables the output after a barrier transmission delay and output disable time (t_{DLZ}/t_{DZH}).

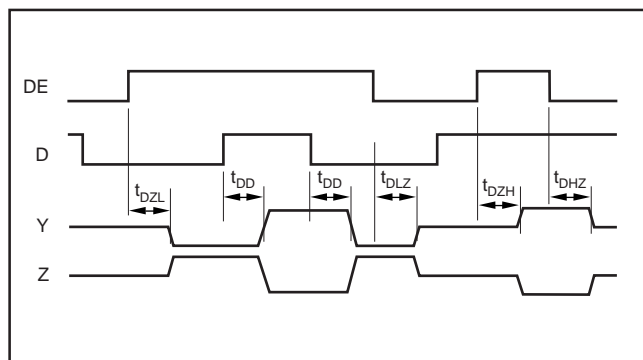

FIGURE 1. ISO422 Data Transmit.

RECEIVE

The receive data is determined by the data bus differential signal after a barrier transmission delay (t_{RZL}). When the difference between the A input and the B input (A-B) is greater than +200mV, the R output will be HIGH. If A-B is more negative than -200mV, the R output is undefined. Since the receiver has a high impedance input, no disable signal is required for the data bus input, which is always

active. The receive enable/disable time is simply the time to enable/disable the R output (t_{RLZ}) and does not require any additional barrier transmission time.

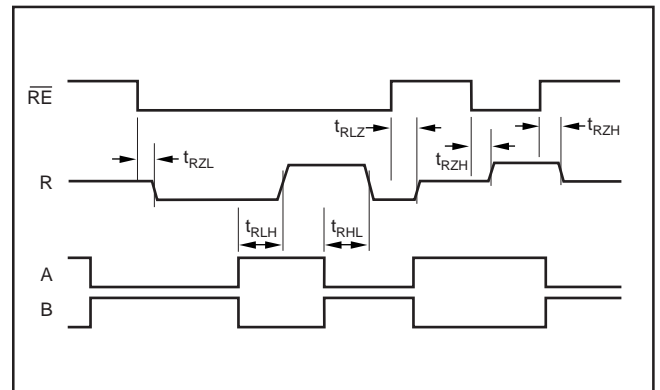

FIGURE 2. ISO422 Data Receive.

DATA CORRUPTION

If, due to transient upset, the data passed across the barrier is corrupted, the data will be restored within 100ns from the end of the corrupting signal.

SYNCHRONIZATION

The data transmitted across the barrier is coded using an internal clock. This clock also captures the incoming asynchronous data and synchronizes it to the clock edges. This will give rise to an rms propagation delay jitter of approximately 50ns.

LOOPBACK

A loopback function is provided by the LBE input. If this input is HIGH, then enabling both the transmitter and the receiver will cause the device to route the D input to the R output, in addition to the data bus outputs. Data on the incoming bus is ignored. This feature allows a simple connection test to be performed during any application. When LBE is LOW, transmit and receive will operate in the normal full-duplex mode.

DATA BUS CONNECTION

ISO422 can be used in half duplex, or full duplex data communication bus systems. It is capable of continuously driving a 54Ω load, equivalent to a double-terminated transmission line, at the fully specified data rate. When connecting to the data bus, the voltage on the A and B input lines must remain between V_{SB} and GND_B . This can be achieved by using a common bus ground connection, such as GND_B , as shown in Figures 5 and 6.

For any system connected to the bus, the isolation provided by ISO422 allows the independent local ground potential to be as high as 1500Vrms with respect to the data bus ground reference. This feature replaces the limited +12V to -7V range of the RS-485 standard with the full-isolation voltage capability of the ISO422.

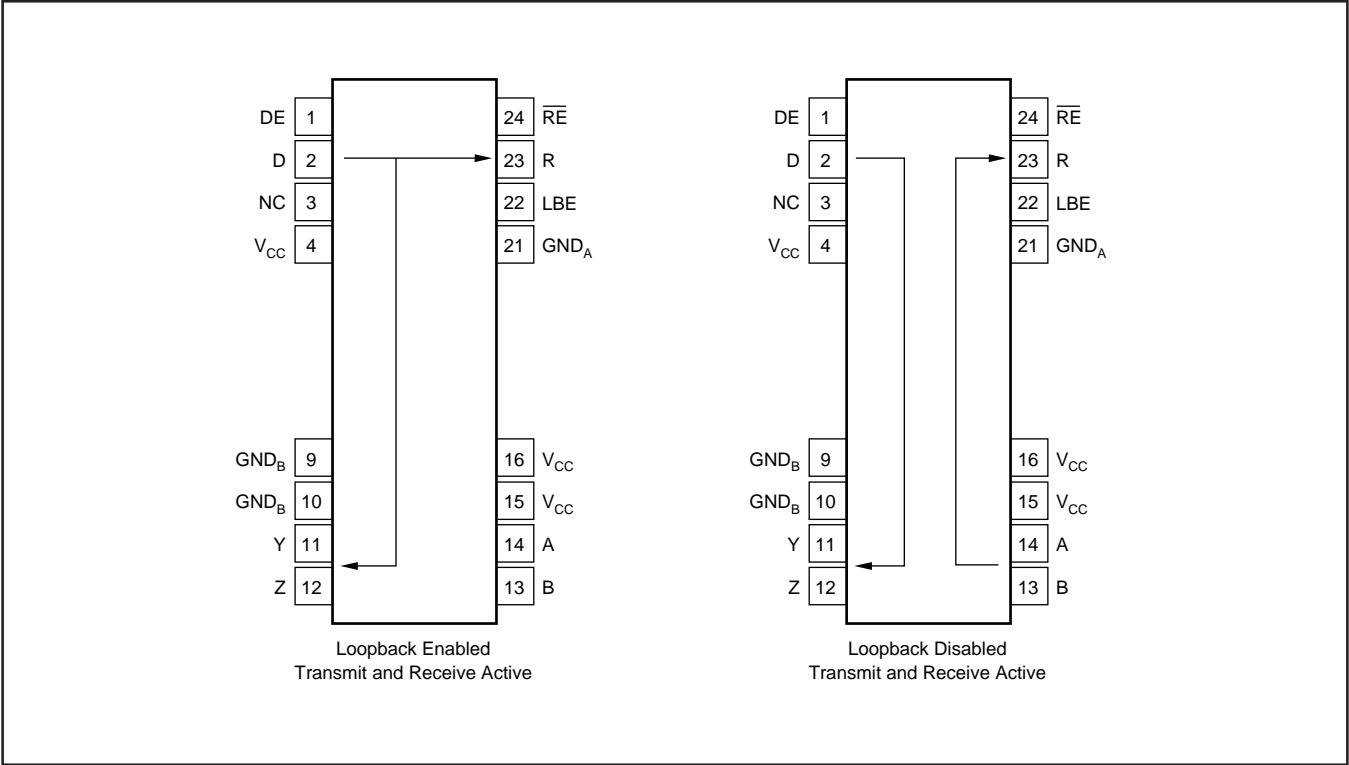

FIGURE 3. Loopback.

CONNECTION TO CAN BUS

Since the bus can be enabled and disabled at the same rate as the data (2.5MHz), it is possible to use ISO422 as an isolated bus driver in CAN systems. Again, the ISO422 bus line must be constrained within the supply voltages.

Figure 4 shows the connections which allow ISO422 to be used in CANbus systems. The DE input of the ISO422 is used as the CAN TX0 input and is used to transmit the data by enabling and disabling the Y and Z outputs. The D and RE inputs of the ISO422 are tied to GND_A. This ensures that the Y output can only pull down, and the Z output can only pull up. With D tied to GND_A, the DE input of ISO422 (TX0 of CAN) activates the Y output as an open drain pull-down driver, and activates the Z output as an open drain pull-up driver. Therefore, the Y line acts as CANL and the Z line acts as CANH. When DE (TX0) is HIGH, ISO422 makes the bus state dominant i.e., Y pulls LOW and Z pulls HIGH. With DE (TX0) LOW, Y and Z are high impedance and the bus state is recessive. Data is received in the normal manner which is half duplex. Line A is connected to CANH, and line B is connected to CANL. The R output becomes RX0. RE is tied to GND_A to keep R (RX0) enabled. If required, RE may be used to disable the RX0 output.

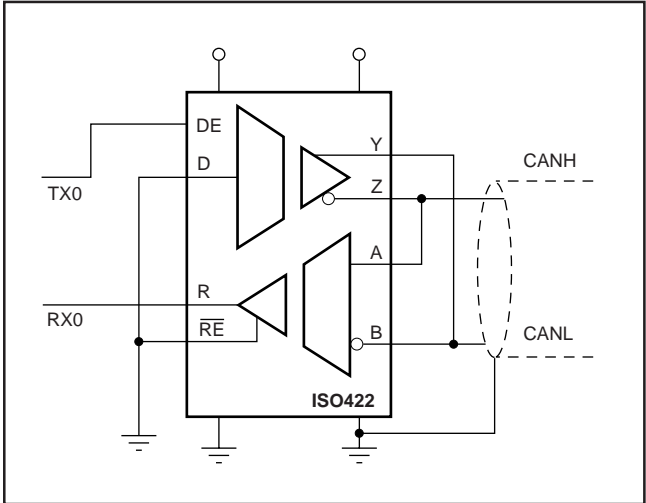

FIGURE 4. CANBus Connection.

TX0	CANH	CANL	BUS	RX0
H	H	L	Dominant	L
L	Hi-Z	Hi-Z	Recessive	H

TABLE I. CAN.

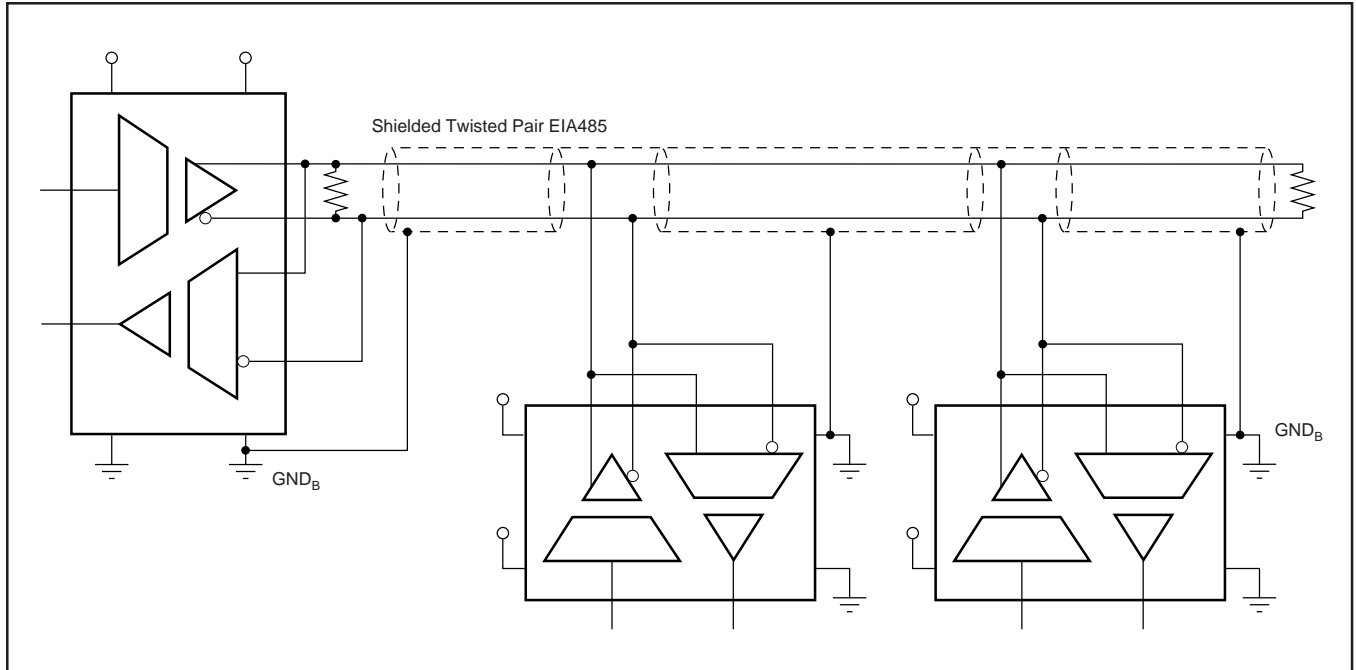

FIGURE 5. Half-Duplex Connection.

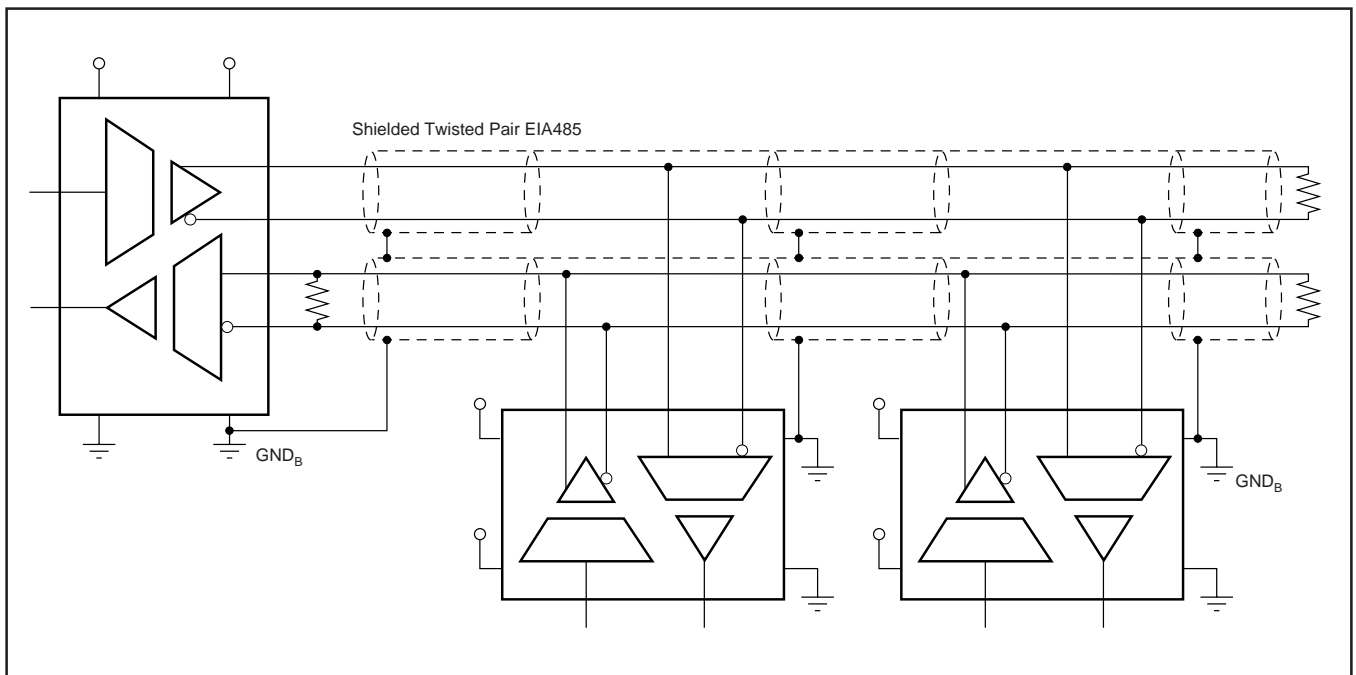

FIGURE 6. Full-Duplex Connection.

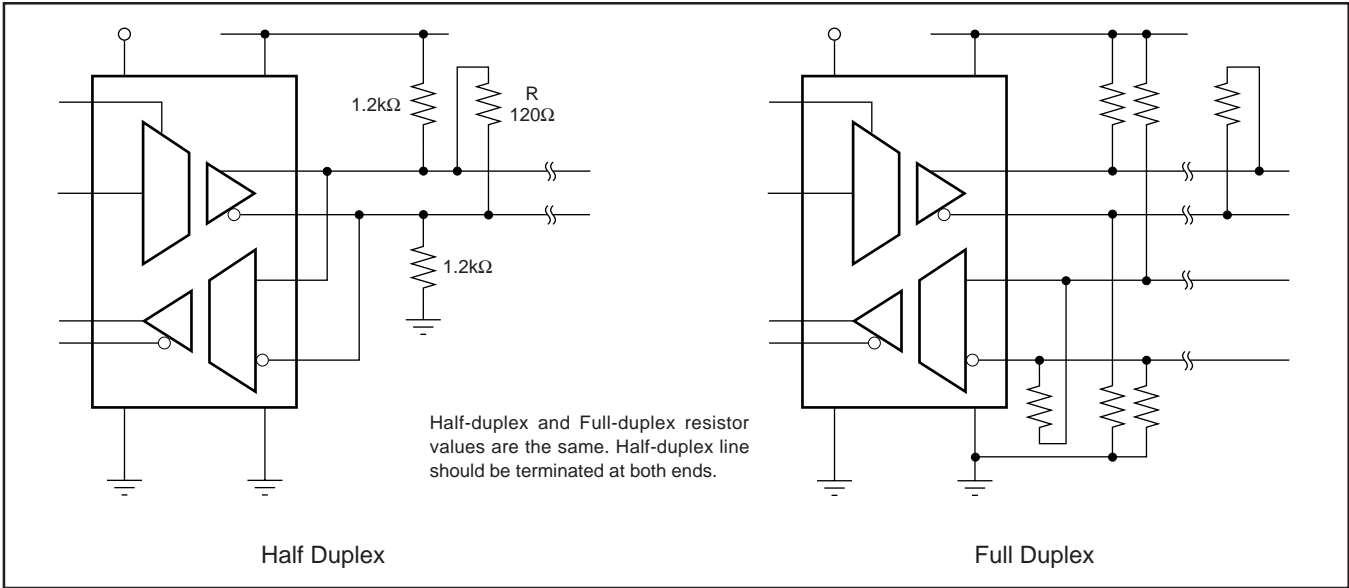

FIGURE 7. Suggested Bus Termination Methods.

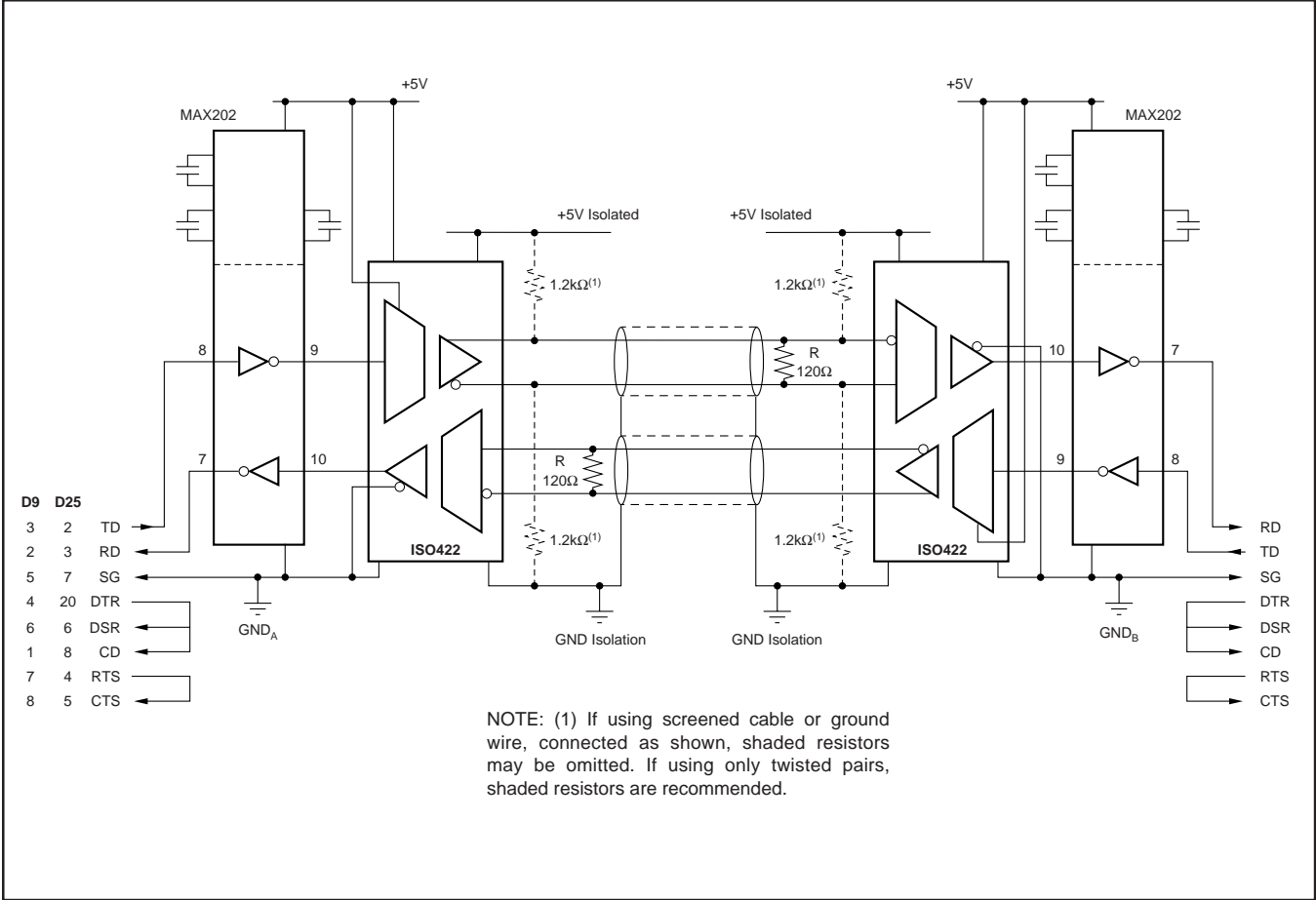

FIGURE 8. Isolated RS232 to RS422. Null Modem Configuration.