

700MHz Differential Twisted-Pair Drivers

The EL5178 and EL5378 are single and triple high bandwidth amplifiers with an output in differential form. They are primarily targeted for applications such as driving twisted-pair lines in component video applications. The inputs can be in either single-ended or differential form but the outputs are always in differential form.

On the EL5178 and EL5378, two feedback inputs provide the user with the ability to set the gain of each device (stable at minimum gain of 2).

The output common mode level for each channel is set by the associated REF pin, which have a -3dB bandwidth of over 110MHz. Generally, these pins are grounded but can be tied to any voltage reference.

All outputs are short circuit protected to withstand temporary overload condition.

The EL5178 is available in 8-pin MSOP and SO packages and EL5378 is available in a 28-pin QSOP package. All specified for operation over the full -40°C to +85°C temperature range.

Pinouts

EL5178
(8-PIN MSOP, SO)
TOP VIEW

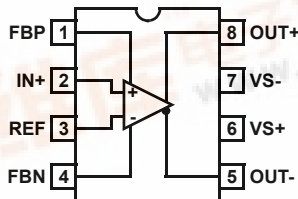

EL5378
(28-PIN QSOP)
TOP VIEW

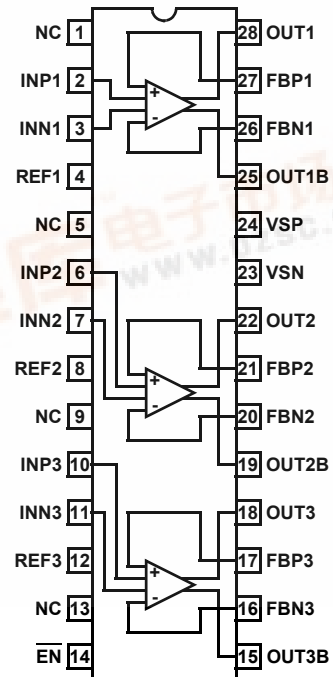

Features

- Fully differential inputs, outputs, and feedback
- Differential input range $\pm 2.3V$
- 700MHz 3dB bandwidth
- 1000V/ μs slew rate
- Low distortion at 5MHz and 20MHz
- Single 5V or dual $\pm 5V$ supplies
- 60mA maximum output current
- Low power - 12.5mA per channel
- Pb-free available (RoHS compliant)

Applications

- Twisted-pair driver
- Differential line driver
- VGA over twisted-pair
- ADSL/HDSL driver
- Single ended to differential amplification
- Transmission of analog signals in a noisy environment

EL5178, EL5378

Ordering Information

PART NUMBER	PACKAGE	TAPE & REEL	PKG. DWG. #
EL5178IS	8-Pin SO	-	MDP0027
EL5178IS-T7	8-Pin SO	7"	MDP0027
EL5178IS-T13	8-Pin SO	13"	MDP0027
EL5178ISZ (See Note)	8-Pin SO (Pb-Free)	-	MDP0027
EL5178ISZ-T7 (See Note)	8-Pin SO (Pb-Free)	7"	MDP0027
EL5178ISZ-T13 (See Note)	8-Pin SO (Pb-Free)	13"	MDP0027
EL5178IY	8-Pin MSOP	-	MDP0043
EL5178IY-T7	8-Pin MSOP	7"	MDP0043
EL5178IY-T13	8-Pin MSOP	13"	MDP0043

PART NUMBER	PACKAGE	TAPE & REEL	PKG. DWG. #
EL5178IYZ (See Note)	8-Pin MSOP (Pb-Free)	-	MDP0043
EL5178IYZ-T7 (See Note)	8-Pin MSOP (Pb-Free)	7"	MDP0043
EL5178IYZ-T13 (See Note)	8-Pin MSOP (Pb-Free)	13"	MDP0043
EL5378IU	28-Pin QSOP	-	MDP0040
EL5378IU-T7	28-Pin QSOP	7"	MDP0040
EL5378IU-T13	28-Pin QSOP	13"	MDP0040
EL5378IUZ (See Note)	28-Pin QSOP (Pb-Free)	-	MDP0040
EL5378IUZ-T7 (See Note)	28-Pin QSOP (Pb-Free)	7"	MDP0040
EL5378IUZ-T13 (See Note)	28-Pin QSOP (Pb-Free)	13"	MDP0040

NOTE: Intersil Pb-free products employ special Pb-free material sets; molding compounds/die attach materials and 100% matte tin plate termination finish, which are RoHS compliant and compatible with both SnPb and Pb-free soldering operations. Intersil Pb-free products are MSL classified at Pb-free peak reflow temperatures that meet or exceed the Pb-free requirements of IPC/JEDEC J STD-020.

EL5178, EL5378

Absolute Maximum Ratings (T_A = 25°C)

Supply Voltage (V _{S+} to V _{S-}) 12V	Storage Temperature Range -65°C to +150°C
Maximum Output Current ±60mA	Operating Junction Temperature +135°C
Input Current (all inputs and references) 4mA	Ambient Operating Temperature -40°C to +85°C
ESD MM 300V, HBM 3kV	

CAUTION: Stresses above those listed in "Absolute Maximum Ratings" may cause permanent damage to the device. This is a stress only rating and operation of the device at these or any other conditions above those indicated in the operational sections of this specification is not implied.

IMPORTANT NOTE: All parameters having Min/Max specifications are guaranteed. Typ values are for information purposes only. Unless otherwise noted, all tests are at the specified temperature and are pulsed tests, therefore: T_J = T_C = T_A

Electrical Specifications V_{S+} = +5V, V_{S-} = -5V, T_A = 25°C, V_{IN} = 0V, R_{LD} = 1kΩ, C_{LD} = 2.7pF, [R_F = 604Ω, R_G = 402Ω (EL5178)], [R_F = 402Ω, R_G = 274Ω (EL5378)], unless otherwise specified.

PARAMETER	DESCRIPTION	CONDITIONS	MIN	TYP	MAX	UNIT
AC PERFORMANCE						
BW	-3dB Bandwidth	A _V = 2, C _{LD} = 2.7pF		700		MHz
		A _V = 5, C _{LD} = 2.7pF		80		MHz
		A _V = 2, C _{LD} = 2.7pF, R _{LD} = 200Ω		320		MHz
BW	±0.1dB Bandwidth	A _V = 2, C _{LD} = 2.7pF		45		MHz
SR	Slew Rate, Differential (EL5178)	V _{OUT} = 3V _{P-P} , 20% to 80%	650	850		V/μs
	Slew Rate, Differential (EL5378)	V _{OUT} = 3V _{P-P} , 20% to 80%	650	1000		V/μs
T _{STL}	Settling Time to 0.1%	V _{OUT} = 2V _{P-P}		35		ns
T _{OVR}	Output Overdrive Recovery Time	A _V = 2		20		ns
GBWP	Gain Bandwidth Product			350		MHz
V _{REFBW} (-3dB)	V _{REF} -3dB Bandwidth (EL5378)	C _{LD} = 2.7pF		110		MHz
V _{REFSR+}	V _{REF} Slew Rate - Rise (EL5378)	V _{OUT} = 2V _{P-P} , 20% to 80%		134		V/μs
V _{REFSR-}	V _{REF} Slew Rate - Fall (EL5378)	V _{OUT} = 2V _{P-P} , 20% to 80%		70		V/μs
V _N	Input Voltage Noise	at 10kHz		18		nV/√Hz
I _N	Input Current Noise	at 10kHz		1.5		pA/√Hz
HD2	Second Harmonic Distortion	V _{OUT} = 2V _{P-P} , 5MHz		-83		dBc
		V _{OUT} = 2V _{P-P} , 20MHz		-72		dBc
HD3	Third Harmonic Distortion	V _{OUT} = 2V _{P-P} , 5MHz		-88		dBc
		V _{OUT} = 2V _{P-P} , 20MHz		-70		dBc
dG	Differential Gain at 3.58MHz	R _{LD} = 300Ω, A _V = 2		0.06		%
dθ	Differential Phase at 3.58MHz	R _{LD} = 300Ω, A _V = 2		0.13		°
e _S	Channel Separation (EL5378)	at F = 1MHz		90		dB
INPUT CHARACTERISTICS						
V _{OS}	Input Referred Offset Voltage			±1.9	±30	mV
I _{IN}	Input Bias Current (V _{IN+} , V _{IN-})		-20	-14	-7	μA
I _{REF}	Input Bias Current (V _{REF}) (EL5378)	V _{REF} = ±3.0V	0.05	2.3	4	μA
R _{IN}	Differential Input Resistance			150		kΩ
C _{IN}	Differential Input Capacitance			1		pF
DMIR	Differential Mode Input Range (EL5378)			±2.3		V
CMIR+	Common Mode Positive Input Range at V _{IN+} , V _{IN-} (EL5378)		3.1	3.4		V

EL5178, EL5378

Electrical Specifications $V_{S+} = +5V$, $V_{S-} = -5V$, $T_A = 25^\circ C$, $V_{IN} = 0V$, $R_{LD} = 1k\Omega$, $C_{LD} = 2.7pF$, [$R_F = 604\Omega$, $R_G = 402\Omega$ (EL5178)], [$R_F = 402\Omega$, $R_G = 274\Omega$ (EL5378)], unless otherwise specified. **(Continued)**

PARAMETER	DESCRIPTION	CONDITIONS	MIN	TYP	MAX	UNIT
CMIR-	Common Mode Negative Input Range at V_{IN+} , V_{IN-} (EL5378)			-4.4	-4.1	V
V_{REFIN+}	Positive Reference Input Voltage Range (EL5378)	$V_{IN+} = V_{IN-} = 0V$	3.2	3.7		V
V_{REFIN-}	Negative Reference Input Voltage Range (EL5378)	$V_{IN+} = V_{IN-} = 0V$		-3.3	-3.2	V
V_{REFOS}	Output Offset Relative to V_{REF} (EL5378)			± 50	± 100	mV
CMRR	Input Common Mode Rejection Ratio	$V_{IN} = \pm 2.5V$	65	78		dB
OUTPUT CHARACTERISTICS						
V_{OUT}	Output Voltage Swing	$R_L = 1k\Omega$	± 3.4	± 3.7		V
$I_{OUT(Max)}$	Maximum Output Current	$R_L = 10\Omega$, $V_{IN+} = \pm 3.2V$	± 50	± 60	± 100	mA
R_{OUT}	Output Impedance			130		m Ω
SUPPLY						
V_{SUPPLY}	Supply Operating Range	V_{S+} to V_{S-}	4.75		11	V
$I_{S(ON)}$	Power Supply Current - Per Channel		10	12.5	14	mA
$I_{S(OFF)+}$	Positive Power Supply Current - Disabled (EL5378)	\overline{EN} pin tied to 4.8V		1.7	10	μA
$I_{S(OFF)-}$	Negative Power Supply Current - Disabled (EL5378)		-200	-120		μA
PSRR	Power Supply Rejection Ratio	V_S from $\pm 4.5V$ to $\pm 5.5V$	60	75		dB
ENABLE (EL5378 ONLY)						
t_{EN}	Enable Time			130		ns
t_{DS}	Disable Time			1.2		μs
V_{IH}	\overline{EN} Pin Voltage for Power-Up				$V_{S+} - 1.5$	V
V_{IL}	\overline{EN} Pin Voltage for Shut-Down		$V_{S+} - 0.5$			V
I_{IH-EN}	\overline{EN} Pin Input Current High	At $V_{EN} = 5V$		123	200	μA
I_{IL-EN}	\overline{EN} Pin Input Current Low	At $V_{EN} = 0V$	-20	-8		μA

EL5178, EL5378

Pin Descriptions

EL5178	EL5378	PIN NAME	PIN FUNCTION
1	17, 21, 27	FBP1, 2, 3	Feedback from non-inverting outputs
2	2, 6, 10	INP1, 2, 3	Non-inverting inputs
3	3, 7, 11	INN1, 2, 3	Inverting inputs, note that on EL5178, this pin is also the REF pin
4	16, 20, 26	FBN1, 2, 3	Feedback from inverting outputs
5	15, 19, 25	OUT1B, 2B, 3B	Inverting outputs
6	24	VSP	Positive supply
7	23	VSN	Negative supply
8	18, 22, 28	OUT1, 2, 3	Non-inverting outputs
	1, 5, 9, 13	NC	No connect; grounded for best crosstalk performance
	4, 8, 12	REF1, 2, 3	Reference inputs, sets common-mode output voltage
	14	$\overline{\text{EN}}$	ENABLE

Typical Performance Curves

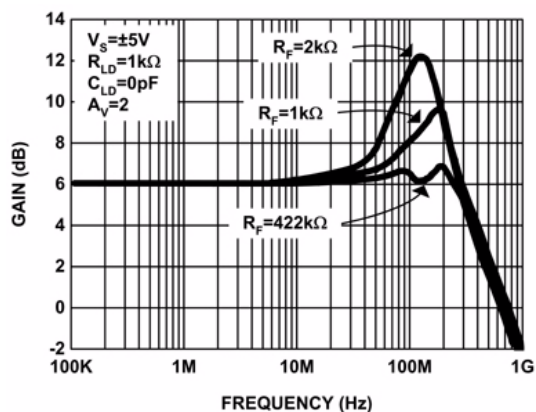

FIGURE 1. EL5178 FREQUENCY RESPONSE FOR VARIOUS R_F

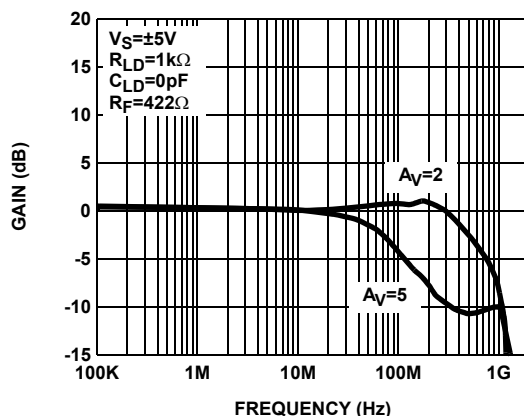

FIGURE 2. EL5178 FREQUENCY RESPONSE FOR VARIOUS GAIN

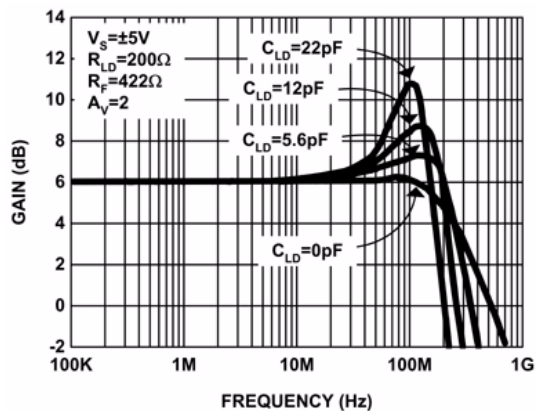

FIGURE 3. EL5178 FREQUENCY RESPONSE FOR VARIOUS C_{LD}

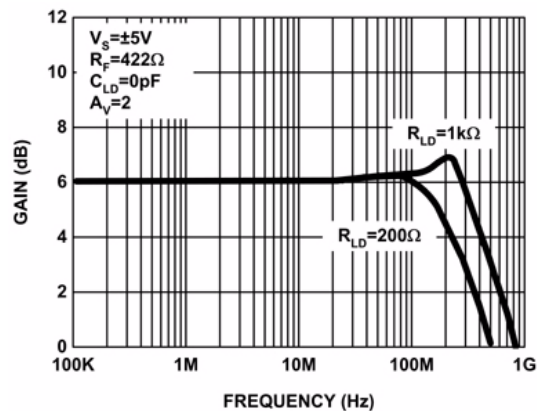

FIGURE 4. EL5178 FREQUENCY RESPONSE FOR VARIOUS R_{LD}

Typical Performance Curves

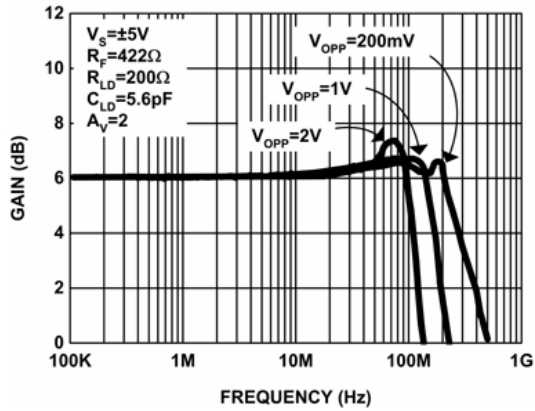

FIGURE 5. EL5178 FREQUENCY RESPONSE FOR VARIOUS V_{OPP}

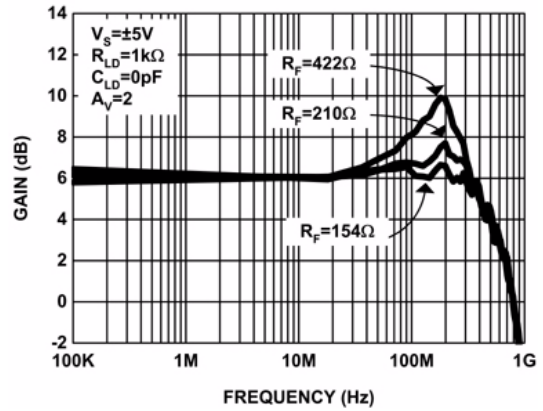

FIGURE 6. EL5378 FREQUENCY RESPONSE FOR VARIOUS R_F

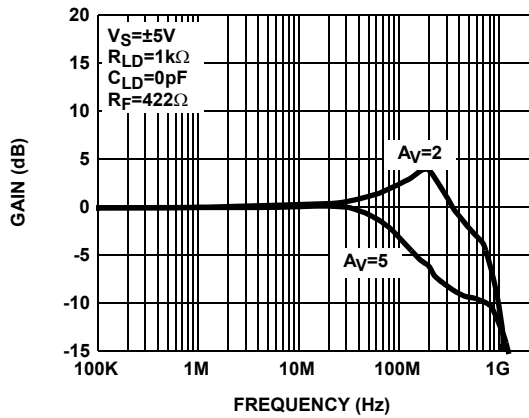

FIGURE 7. EL5378 FREQUENCY RESPONSE FOR VARIOUS GAIN

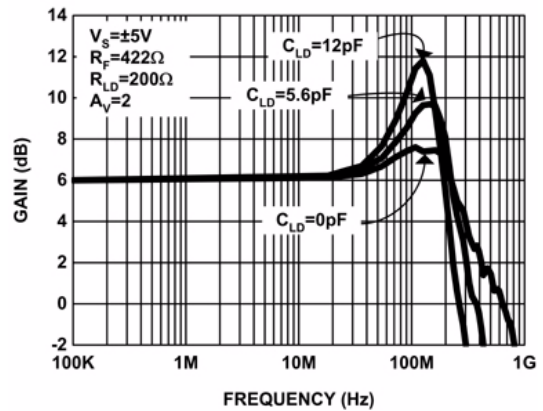

FIGURE 8. EL5378 FREQUENCY RESPONSE FOR VARIOUS C_{LD}

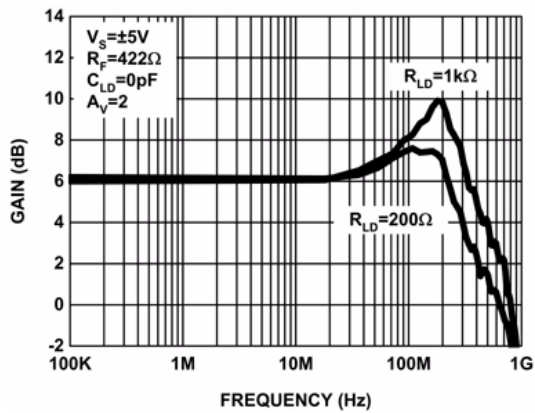

FIGURE 9. EL5378 FREQUENCY RESPONSE FOR VARIOUS R_{LD}

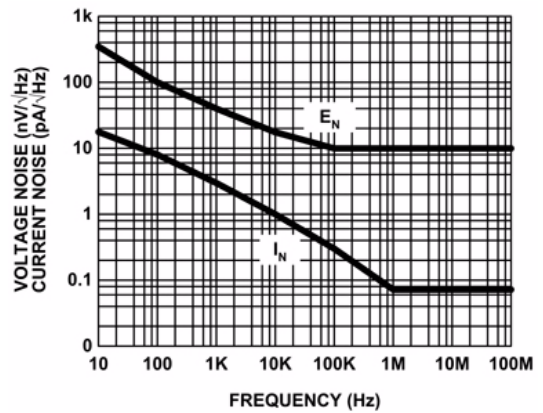

FIGURE 10. VOLTAGE AND CURRENT NOISE vs FREQUENCY

Typical Performance Curves

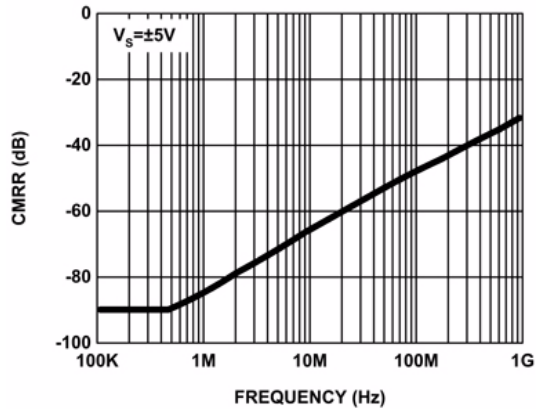

FIGURE 11. CMRR vs FREQUENCY

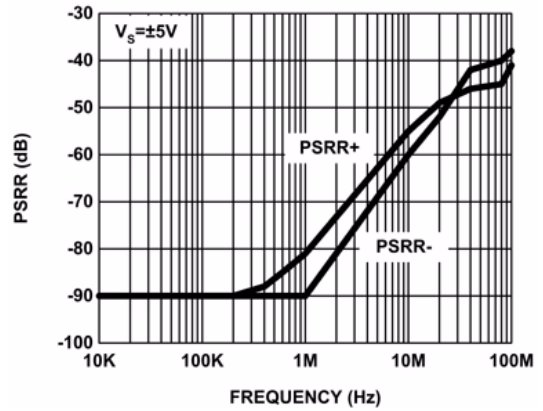

FIGURE 12. DIFFERENTIAL PSRR vs FREQUENCY

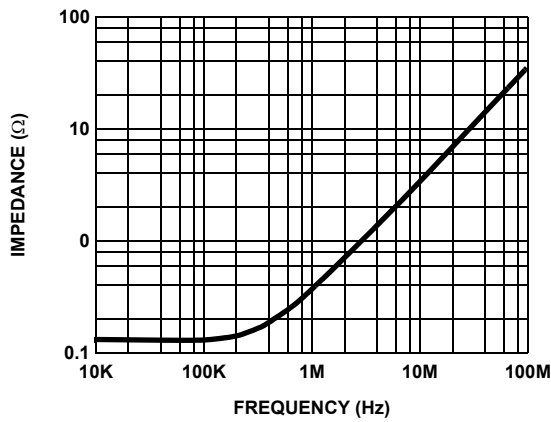

FIGURE 13. OUTPUT IMPEDANCE vs FREQUENCY

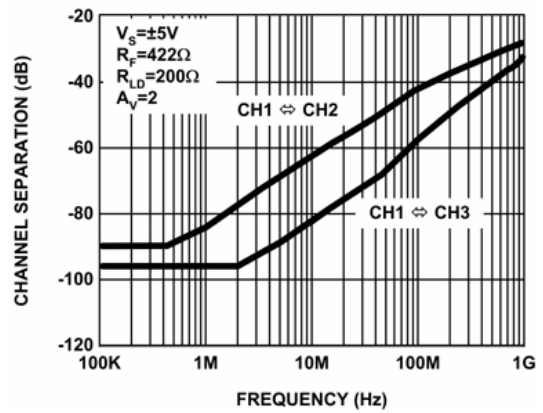

FIGURE 14. EL5378 CHANNEL SEPARATION

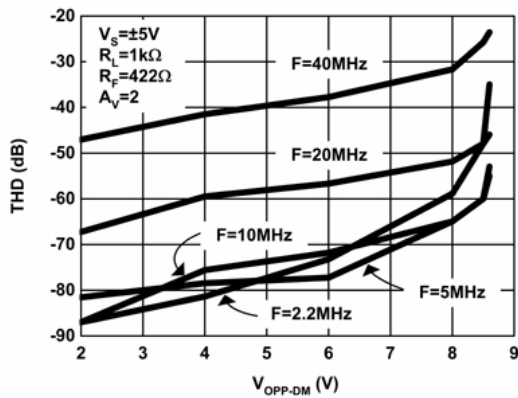

FIGURE 15. TOTAL HARMONIC DISTORTION vs DIFFERENTIAL OUTPUT SWING

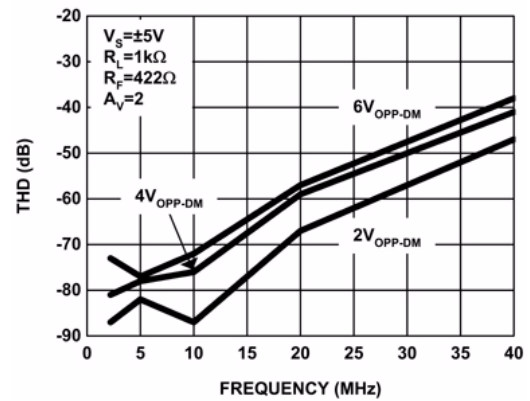

FIGURE 16. TOTAL HARMONIC DISTORTION vs FREQUENCY

Typical Performance Curves

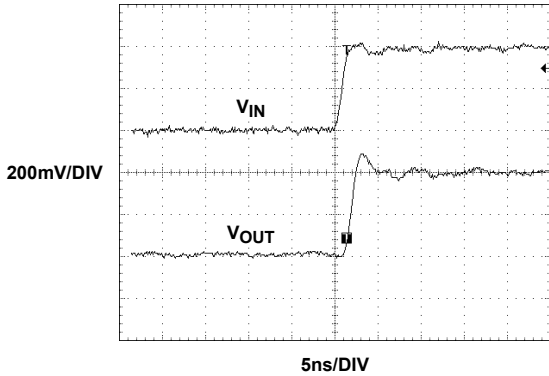

FIGURE 17. SMALL SIGNAL TRANSIENT RESPONSE

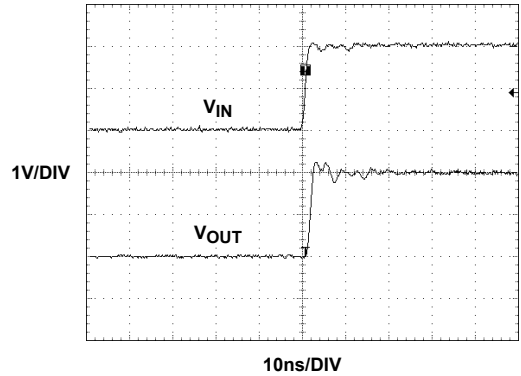

FIGURE 18. LARGE SIGNAL TRANSIENT RESPONSE

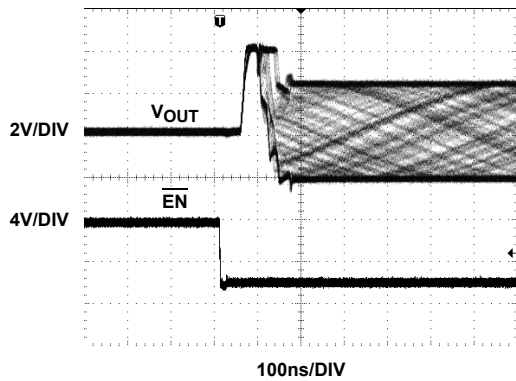

FIGURE 19. EL5378 ENABLED RESPONSE

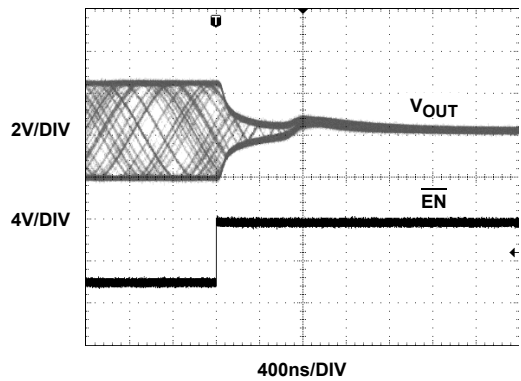

FIGURE 20. EL5378 DISABLED RESPONSE

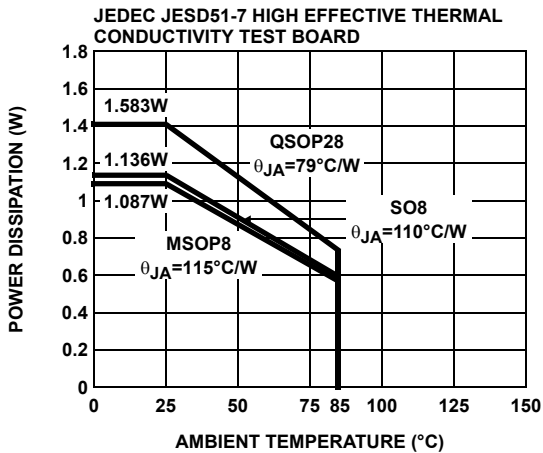

FIGURE 21. PACKAGE POWER DISSIPATION vs AMBIENT TEMPERATURE

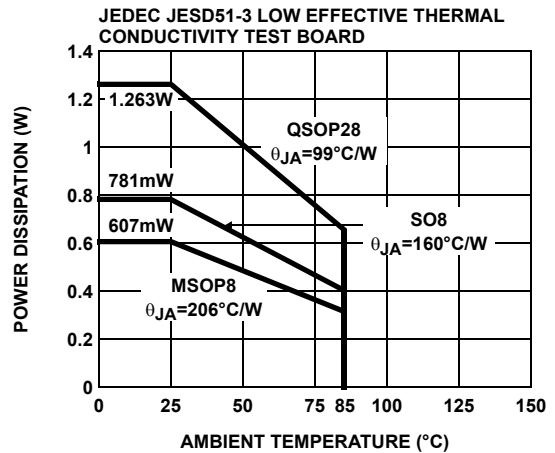
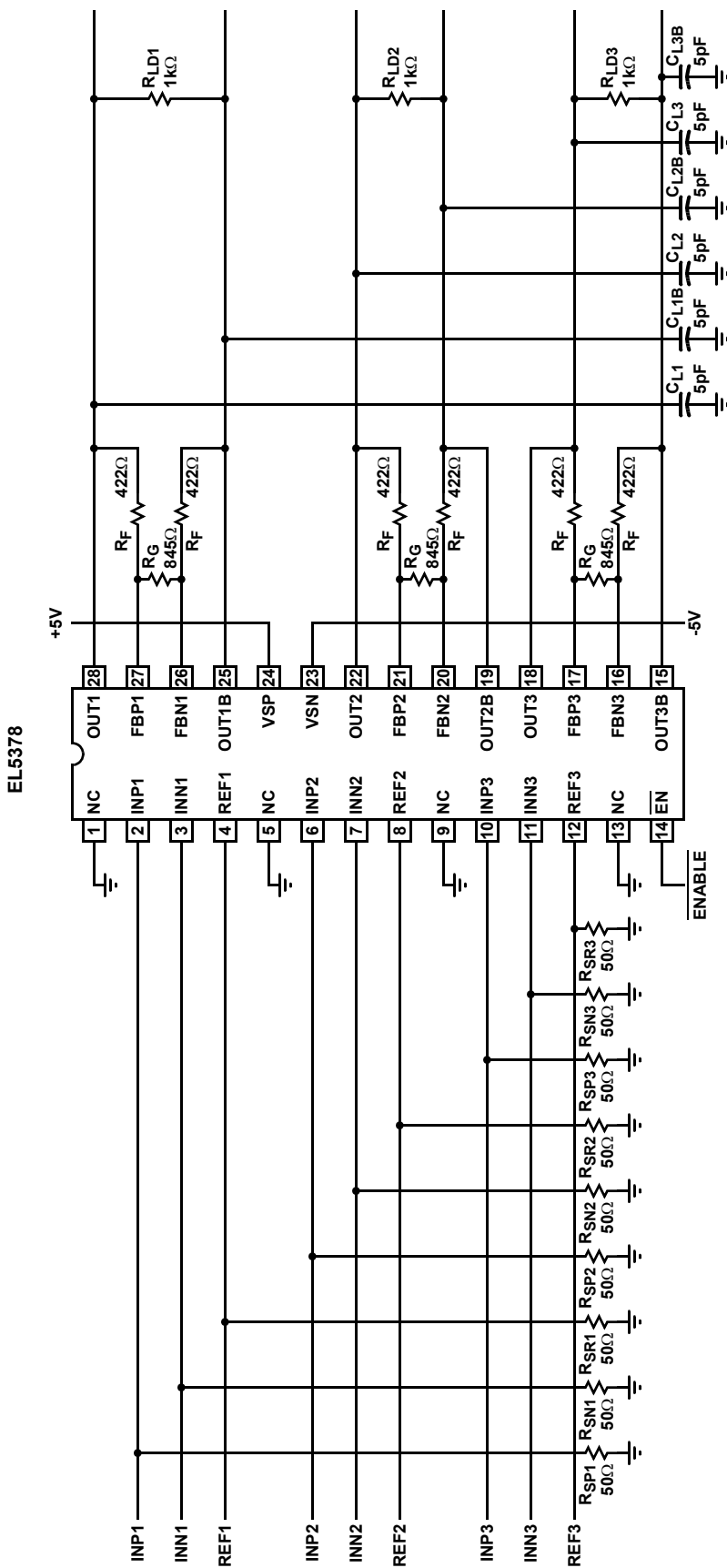
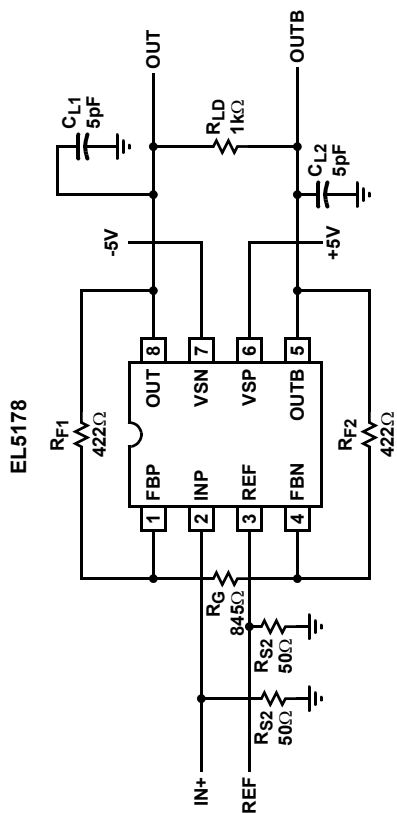
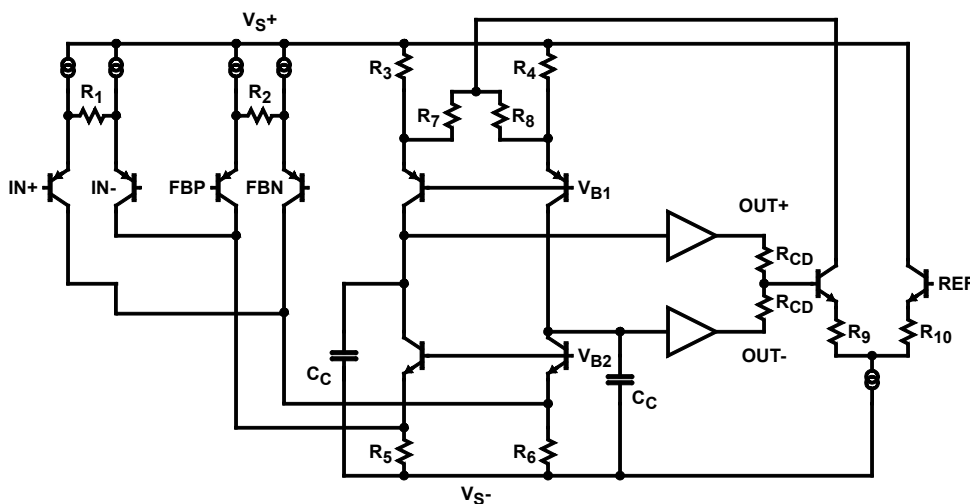

FIGURE 22. PACKAGE POWER DISSIPATION vs AMBIENT TEMPERATURE

Connection Diagrams



Simplified Schematic



Description of Operation and Application Information

Product Description

The EL5178 and EL5378 are wide bandwidth, low power and single/differential ended to differential output amplifiers. The EL5178 is a single channel differential amplifier. Since the I_{N-} pin and REF pin are tied together internally, the EL5178 can be used as a single ended to differential converter. The EL5378 is a triple channel differential amplifier. The EL5378 have a separate I_{N-} pin and REF pin for each channel. It can be used as single/differential ended to differential converter. The EL5178 and EL5378 are internally compensated for closed loop gain of 1 or greater. Connected in gain of 2 and driving a $1\text{k}\Omega$ differential load, the EL5178 and EL5378 have a -3dB bandwidth of 700MHz . Driving a 200Ω differential load at gain of 2, the bandwidth is about 320MHz . The EL5378 is available with a power down feature to reduce the power while the amplifier is disabled.

Input, Output, and Supply Voltage Range

The EL5178 and EL5378 have been designed to operate with a single supply voltage of 5V to 10V or a split supplies with its total voltage from 5V to 10V . The amplifiers have an input common mode voltage range from -4.3V to 3.4V for $\pm 5\text{V}$ supply. The differential mode input range (DMIR) between the two inputs is from -2.3V to $+2.3\text{V}$. The input voltage range at the REF pin is from -3.3V to 3.7V . If the input common mode or differential mode signal is outside the above-specified ranges, it will cause the output signal distorted.

The output of the EL5178 and EL5378 can swing from -3.8V to $+3.8\text{V}$ at $1\text{k}\Omega$ differential load at $\pm 5\text{V}$ supply. As the load resistance becomes lower, the output swing is reduced.

Differential and Common Mode Gain Settings

For EL5178, since the I_{N-} pin and REF pin are bounded together as the REF pin in an 8-pin package, the signal at the REF pin is part of the common mode signal and also part of the differential mode signal. For the true balance differential outputs, the REF pin must be tied to the same bias level as the I_{N+} pin. For a $\pm 5\text{V}$ supply, just tie the REF pin to GND if the I_{N+} pin is biased at 0V with a 50Ω or 75Ω termination resistor. For a single supply application, if the I_{N+} is biased to half of the rail, the REF pin should be biased to half of the rail also.

The gain setting for EL5178 is:

$$V_{\text{ODM}} = V_{\text{IN}+} \times \left(1 + \frac{R_{F1} + R_{F2}}{R_G} \right)$$

$$V_{\text{ODM}} = V_{\text{IN}+} \times \left(1 + \frac{2R_F}{R_G} \right)$$

$$V_{\text{OCM}} = V_{\text{REF}} = 0\text{V}$$

Where:

$$V_{\text{REF}} = 0\text{V}$$

$$R_{F1} = R_{F2} = R_F$$

EL5378 have a separate I_{N-} pin and REF pin. It can be used as a single/differential ended to differential converter. The voltage applied at REF pin can set the output common mode voltage and the gain is one.

EL5178, EL5378

The gain setting for EL5378 is:

$$V_{ODM} = (V_{IN+} - V_{IN-}) \times \left(1 + \frac{R_{F1} + R_{F2}}{R_G} \right)$$

$$V_{ODM} = (V_{IN+} - V_{IN-}) \times \left(1 + \frac{2R_F}{R_G} \right)$$

$$V_{OCM} = V_{REF}$$

Where:

$$R_{F1} = R_{F2} = R_F$$

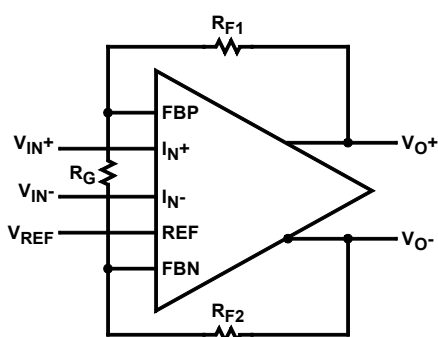

FIGURE 23.

Choice of Feedback Resistor and Gain Bandwidth Product

For gains greater than 1, the feedback resistor forms a pole with the parasitic capacitance at the inverting input. As this pole becomes smaller, the amplifier's phase margin is reduced. This causes ringing in the time domain and peaking in the frequency domain. Therefore, R_F has some maximum value that should not be exceeded for optimum performance. If a large value of R_F must be used, a small capacitor in the few Pico farad range in parallel with R_F can help to reduce the ringing and peaking at the expense of reducing the bandwidth.

The bandwidth of the EL5178 and EL5378 depends on the load and the feedback network. R_F and R_G appear in parallel with the load for gains other than 1. As this combination gets smaller, the bandwidth falls off. Consequently, R_F also has a minimum value that should not be exceeded for optimum bandwidth performance. For the gains other than 1, optimum response is obtained with R_F between 500Ω to 1kΩ.

The EL5178 and EL5378 have a gain bandwidth product of 350MHz for $R_{LD} = 1k\Omega$. For gains ≥ 5 , its bandwidth can be predicted by the following equation:

$$\text{Gain} \times \text{BW} = 300\text{MHz}$$

Driving Capacitive Loads and Cables

The EL5178 and EL5378 can drive 23pF differential capacitor in parallel with 200Ω differential load with less than 5dB of peaking at gain of 2. If less peaking is desired in applications, a small series resistor (usually between 5Ω to 50Ω) can be placed in series with each output to eliminate most peaking. However, this will reduce the gain slightly. If the gain setting is greater than 2, the gain resistor R_G can then be chosen to make up for any gain loss which may be created by the additional series resistor at the output.

When used as a cable driver, double termination is always recommended for reflection-free performance. For those applications, a back-termination series resistor at the amplifier's output will isolate the amplifier from the cable and allow extensive capacitive drive. However, other applications may have high capacitive loads without a back-termination resistor. Again, a small series resistor at the output can help to reduce peaking.

Disable/Power-Down (for EL5378 only)

The EL5378 can be disabled and placed its outputs in a high impedance state. The turn off time is about 1.2μs and the turn on time is about 130ns. When disabled, the amplifier's supply current is reduced to 1.7μA for I_{S+} and 120μA for I_{S-} typically, thereby effectively eliminating the power consumption. The amplifier's power down can be controlled by standard CMOS signal levels at the EN pin. The applied logic signal is relative to V_{S+} pin. Letting the $\overline{\text{EN}}$ pin float or applying a signal that is less than 1.5V below V_{S+} will enable the amplifier. The amplifier will be disabled when the signal at $\overline{\text{EN}}$ pin is above $V_{S+} - 0.5V$.

Output Drive Capability

The EL5178 and EL5378 have internal short circuit protection. Its typical short circuit current is $\pm 60\text{mA}$. If the output is shorted indefinitely, the power dissipation could easily increase such that the part will be destroyed. Maximum reliability is maintained if the output current never exceeds $\pm 60\text{mA}$. This limit is set by the design of the internal metal interconnections.

Power Dissipation

With the high output drive capability of the EL5178 and EL5378. It is possible to exceed the 135°C absolute maximum junction temperature under certain load current conditions. Therefore, it is important to calculate the maximum junction temperature for the application to determine if the load conditions or package types need to be modified for the amplifier to remain in the safe operating area.

The maximum power dissipation allowed in a package is determined according to:

$$PD_{MAX} = \frac{T_{JMAX} - T_{AMAX}}{\Theta_{JA}}$$

EL5178, EL5378

Where:

T_{JMAX} = Maximum junction temperature

T_{AMAX} = Maximum ambient temperature

θ_{JA} = Thermal resistance of the package

The maximum power dissipation actually produced by an IC is the total quiescent supply current times the total power supply voltage, plus the power in the IC due to the load, or:

$$PD = i \times \left(V_S \times I_{SMAX} + V_S \times \frac{\Delta V_O}{R_{LD}} \right)$$

Where:

V_S = Total supply voltage

I_{SMAX} = Maximum quiescent supply current per channel

ΔV_O = Maximum differential output voltage of the application

R_{LD} = Differential load resistance

I_{LOAD} = Load current

i = Number of channels

By setting the two PD_{MAX} equations equal to each other, we can solve the output current and R_{LD} to avoid the device overheat.

Typical Applications

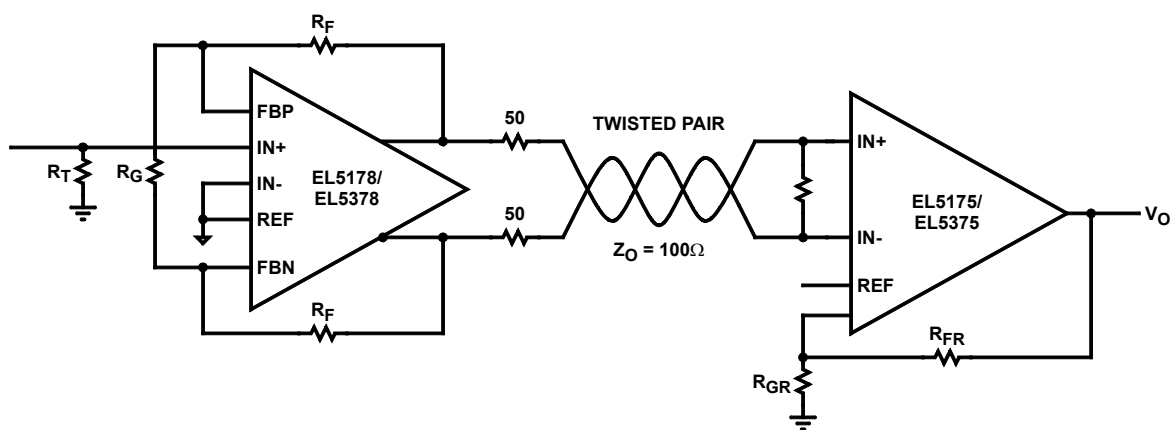

FIGURE 24. TWISTED PAIR CABLE RECEIVER

As the signal is transmitted through a cable, the high frequency signal will be attenuated. One way to compensate this loss is to boost the high frequency gain at the receiver side.

Power Supply Bypassing and Printed Circuit Board Layout

As with any high frequency device, a good printed circuit board layout is necessary for optimum performance. Lead lengths should be as short as possible. The power supply pin must be well bypassed to reduce the risk of oscillation. For normal single supply operation, where the V_{S-} pin is connected to the ground plane, a single 4.7 μ F tantalum capacitor in parallel with a 0.1 μ F ceramic capacitor from V_{S+} to GND will suffice. This same capacitor combination should be placed at each supply pin to ground if split supplies are to be used. In this case, the V_{S-} pin becomes the negative supply rail.

For good AC performance, parasitic capacitance should be kept to minimum. Use of wire wound resistors should be avoided because of their additional series inductance. Use of sockets should also be avoided if possible. Sockets add parasitic inductance and capacitance that can result in compromised performance. Minimizing parasitic capacitance at the amplifier's inverting input pin is very important. The feedback resistor should be placed very close to the inverting input pin. Strip line design techniques are recommended for the signal traces.

EL5178, EL5378

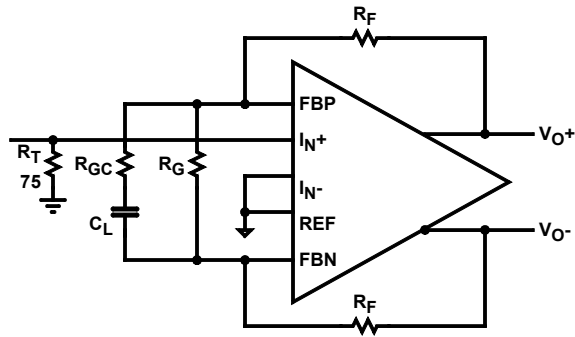

$$\text{DC Gain} = 1 + \frac{2R_F}{R_G}$$

$$\text{(HF)Gain} = 1 + \frac{2R_F}{R_G \parallel R_{GC}}$$

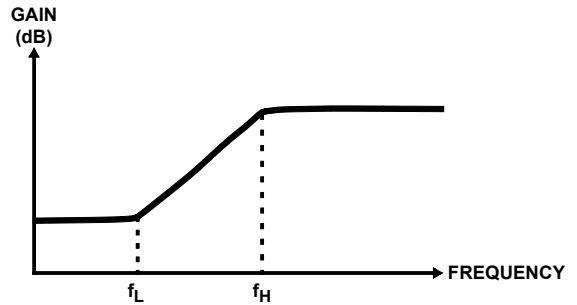

$$f_L \cong \frac{1}{2\pi R_G C_C}$$

$$f_H \cong \frac{1}{2\pi R_{GC} C_C}$$

FIGURE 25. TRANSMIT EQUALIZER

MSOP Package Outline Drawing

DIMENSION TABLE			
Symbol	MSOP8	MSOP10	Tolerance
A	1.10	1.10	MAX.
A1	0.10	0.10	+/- 0.05
A2	0.86	0.86	+/- 0.09
D ⁽¹⁾⁽³⁾	3.00	3.00	+/- 0.10
E	4.90	4.90	+/- 0.15
E1 ⁽²⁾⁽³⁾	3.00	3.00	+/- 0.10
L	0.55	0.55	+/- 0.15
L1	0.95	0.95	Basic
b	0.33	0.23	+0.07/-0.08
c	0.18	0.18	+/- 0.05
e	0.65	0.50	Basic
N	8	10	Reference

Notes:

- (1) Plastic or metal protrusions of 0.15 mm maximum per side are not included.
- (2) Plastic interlead protrusions of 0.25 mm maximum per side are not included.
- (3) Dimensions "D" and "E1" are measured at Datum Plane "H".
- (4) Dimensioning and tolerancing per ASME Y14.5M-1994.

Drawing #: MDP0043	PACKAGE OUTLINE DRAWING MINI SO PACKAGE (MSOP) PACKAGE FAMILY Semiconductor, Inc. HIGH PERFORMANCE ANALOG INTEGRATED CIRCUITS
Rev: C	
Date: 6/14/99	
Units: mm	
JEDEC Reg: MO-187	

EL5178, EL5378

SO Package Outline Drawing

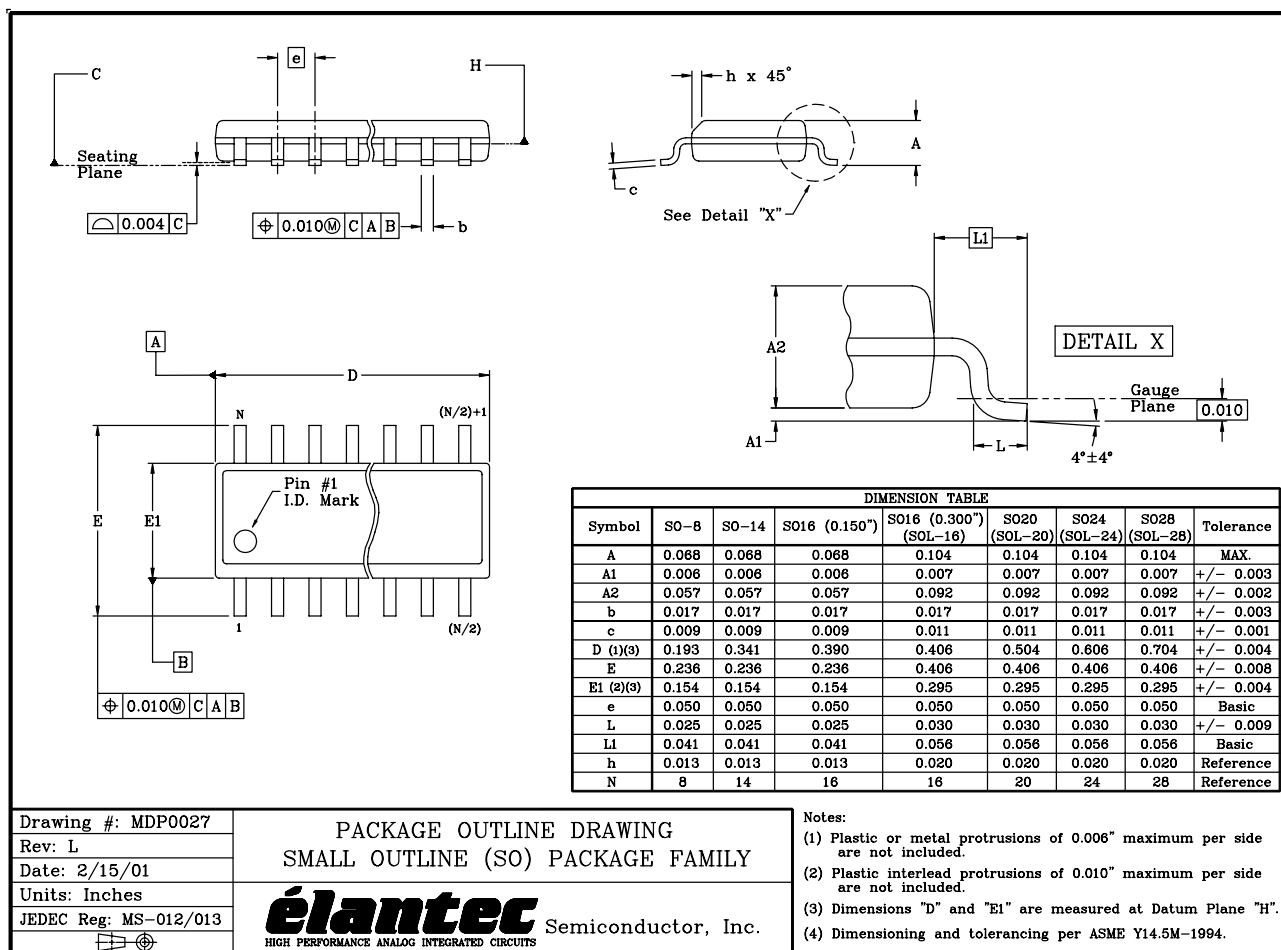

Drawing #: MDP0027
 Rev: L
 Date: 2/15/01
 Units: Inches
 JEDEC Reg: MS-012/013

PACKAGE OUTLINE DRAWING
 SMALL OUTLINE (SO) PACKAGE FAMILY

élan Semiconductor, Inc.
 HIGH PERFORMANCE ANALOG INTEGRATED CIRCUITS

- Notes:
- (1) Plastic or metal protrusions of 0.006" maximum per side are not included.
 - (2) Plastic interlead protrusions of 0.010" maximum per side are not included.
 - (3) Dimensions "D" and "E1" are measured at Datum Plane "H".
 - (4) Dimensioning and tolerancing per ASME Y14.5M-1994.

EL5178, EL5378

QSOP Package Outline Drawing

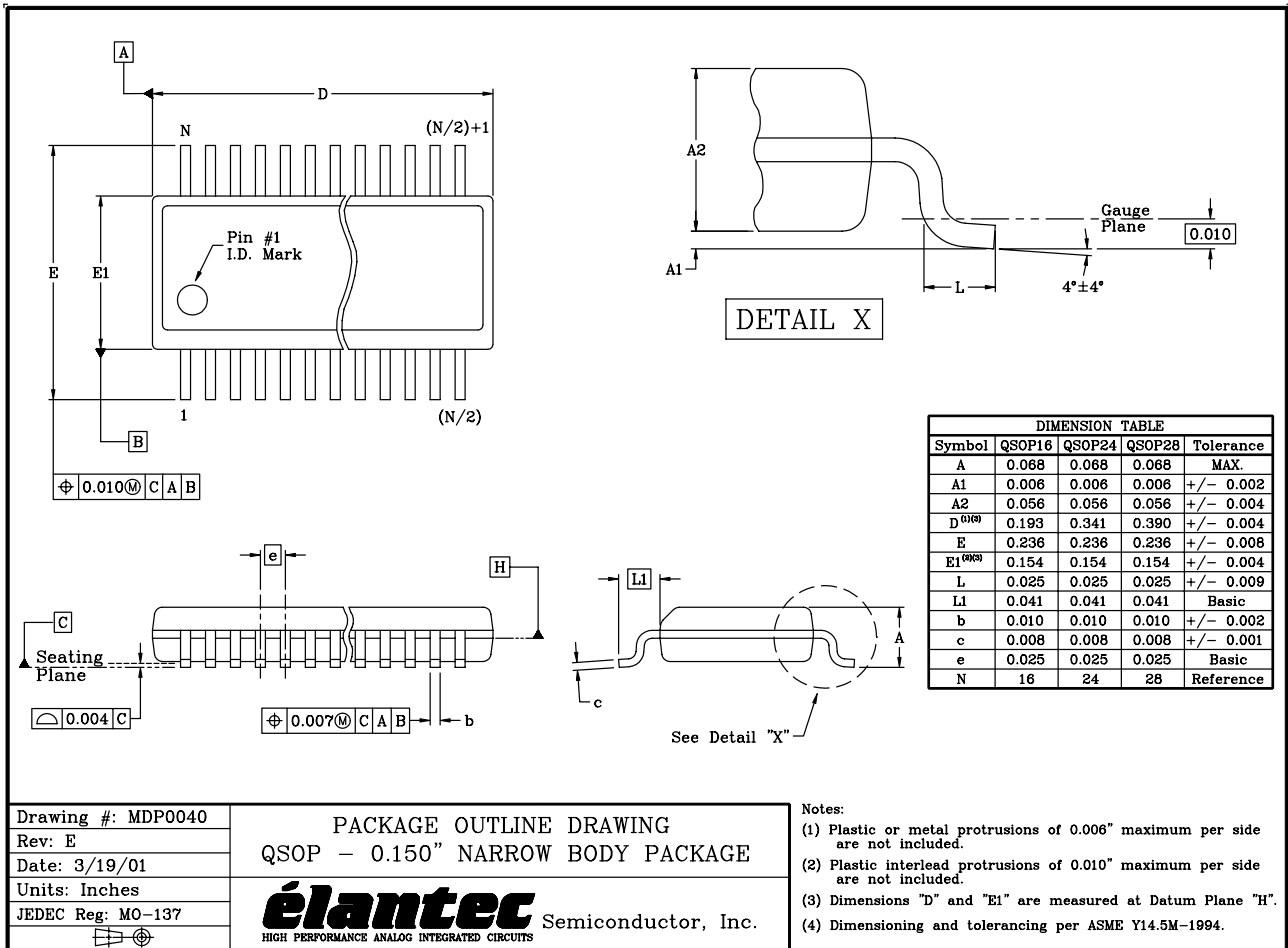

NOTE: The package drawing shown here may not be the latest version. To check the latest revision, please refer to the Intersil website at <http://www.intersil.com/design/packages/index.asp>

All Intersil U.S. products are manufactured, assembled and tested utilizing ISO9000 quality systems. Intersil Corporation's quality certifications can be viewed at www.intersil.com/design/quality

Intersil products are sold by description only. Intersil Corporation reserves the right to make changes in circuit design, software and/or specifications at any time without notice. Accordingly, the reader is cautioned to verify that data sheets are current before placing orders. Information furnished by Intersil is believed to be accurate and reliable. However, no responsibility is assumed by Intersil or its subsidiaries for its use; nor for any infringements of patents or other rights of third parties which may result from its use. No license is granted by implication or otherwise under any patent or patent rights of Intersil or its subsidiaries.

For information regarding Intersil Corporation and its products, see www.intersil.com