

**14A, 30V, 0.0078 Ohm, N-Channel, Logic Level, Power MOSFET**

**Packaging**

SO8 (JEDEC MS-012AA)

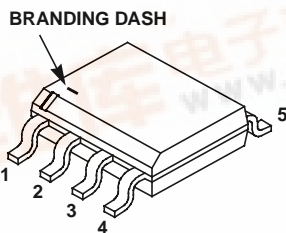

**Symbol**

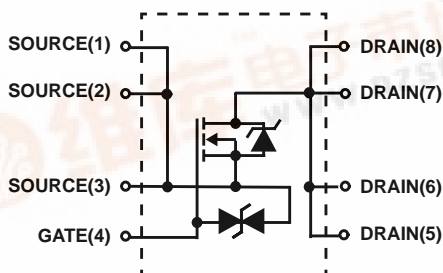

**Features**

- Ultra Low On-Resistance
  - $r_{DS(ON)} = 0.0078\Omega, V_{GS} = 10V$
  - $r_{DS(ON)} = 0.010\Omega, V_{GS} = 4.5V$
  - $r_{DS(ON)} = 0.012\Omega, V_{GS} = 4.0V$
- Gate to Source Protection Diode
- Simulation Models
  - Temperature Compensated PSpice™ and SABER Electrical Models
  - Spice and SABER Thermal Impedance Models
  - www.intersil.com
- Peak Current vs Pulse Width Curve
- Transient Thermal Impedance Curve vs Board Mounting Area
- Switching Time vs  $R_{GS}$  Curves

**Ordering Information**

PART NUMBER	PACKAGE	BRAND
ITF86130SK8T	SO8	86130

NOTE: When ordering, use the entire part number. ITF86130SK8T is available only in tape and reel.

**Absolute Maximum Ratings**  $T_A = 25^\circ C$ , Unless Otherwise Specified

	ITF86130SK8T	UNITS
Drain to Source Voltage (Note 1) . . . . .	30	V
Drain to Gate Voltage ( $R_{GS} = 20k\Omega$ ) (Note 1) . . . . .	30	V
Gate to Source Voltage . . . . .	$\pm 20$	V
<b>Drain Current</b>		
Continuous ( $T_A = 25^\circ C, V_{GS} = 10V$ ) (Figure 2) (Note 2) . . . . .	14.0	A
Continuous ( $T_A = 25^\circ C, V_{GS} = 4.5V$ ) (Note 2) . . . . .	12.0	A
Continuous ( $T_A = 100^\circ C, V_{GS} = 4.5V$ ) (Note 2) . . . . .	7.0	A
Continuous ( $T_A = 100^\circ C, V_{GS} = 4.0V$ ) (Note 2) . . . . .	7.0	A
Pulsed Drain Current . . . . .	Figure 4	A
<b>Power Dissipation (Note 2)</b> . . . . .		
Derate Above $25^\circ C$ . . . . .	2.5	W
Operating and Storage Temperature . . . . .	20	$mW/^\circ C$
Maximum Temperature for Soldering . . . . .	-55 to 150	$^\circ C$
<b>Maximum Temperature for Soldering</b>		
Leads at 0.063in (1.6mm) from Case for 10s. . . . .	300	$^\circ C$
Package Body for 10s, See Tech brief TB370 . . . . .	260	$^\circ C$

NOTES:

1.  $T_J = 25^\circ C$  to  $125^\circ C$ .
2.  $50^\circ C/W$  measured using FR-4 board with  $0.76in^2$  ( $490.3mm^2$ ) copper pad at 10s.

**CAUTION:** Stresses above those listed in "Absolute Maximum Ratings" may cause permanent damage to the device. This is a stress only rating and operation of the device at these or any other conditions above those indicated in the operational sections of this specification is not implied.



## ITF86130SK8T

### Electrical Specifications $T_A = 25^\circ\text{C}$ , Unless Otherwise Specified

PARAMETER	SYMBOL	TEST CONDITIONS	MIN	TYP	MAX	UNITS	
<b>OFF STATE SPECIFICATIONS</b>							
Drain to Source Breakdown Voltage	$BV_{DSS}$	$I_D = 250\mu\text{A}$ , $V_{GS} = 0\text{V}$ (Figure 11)	30	-	-	V	
Zero Gate Voltage Drain Current	$I_{DSS}$	$V_{DS} = 30\text{V}$ , $V_{GS} = 0\text{V}$	-	-	10	$\mu\text{A}$	
Gate to Source Leakage Current	$I_{GSS}$	$V_{GS} = \pm 20\text{V}$	-	-	$\pm 10$	$\mu\text{A}$	
<b>ON STATE SPECIFICATIONS</b>							
Gate to Source Threshold Voltage	$V_{GS(TH)}$	$V_{GS} = V_{DS}$ , $I_D = 250\mu\text{A}$ (Figure 10)	1.5	-	2.5	V	
Drain to Source On Resistance	$r_{DS(ON)}$	$I_D = 14.0\text{A}$ , $V_{GS} = 10\text{V}$ (Figures 8, 9)	-	0.0058	0.0078	$\Omega$	
		$I_D = 7.0\text{A}$ , $V_{GS} = 4.5\text{V}$ (Figure 8)	-	0.007	0.010	$\Omega$	
		$I_D = 7.0\text{A}$ , $V_{GS} = 4.0\text{V}$ (Figure 8)	-	0.008	0.012	$\Omega$	
<b>THERMAL SPECIFICATIONS</b>							
Thermal Resistance Junction to Ambient	$R_{\theta JA}$	Pad Area = $0.76\text{ in}^2$ ( $490.3\text{ mm}^2$ ) (Note 2)	-	-	50	$^\circ\text{C/W}$	
		Pad Area = $0.054\text{ in}^2$ ( $34.8\text{ mm}^2$ ) (Figure 20)	-	-	152	$^\circ\text{C/W}$	
		Pad Area = $0.0115\text{ in}^2$ ( $7.42\text{ mm}^2$ ) (Figure 20)	-	-	189	$^\circ\text{C/W}$	
<b>SWITCHING SPECIFICATIONS (<math>V_{GS} = 4.5\text{V}</math>)</b>							
Turn-On Delay Time	$t_{d(ON)}$	$V_{DD} = 15\text{V}$ , $I_D = 7.0\text{A}$ , $V_{GS} = 4.5\text{V}$ , $R_{GS} = 4.7\Omega$ (Figures 14, 18, 19)	-	23	-	ns	
Rise Time	$t_r$		-	84	-	ns	
Turn-Off Delay Time	$t_{d(OFF)}$		-	33	-	ns	
Fall Time	$t_f$		-	42	-	ns	
<b>SWITCHING SPECIFICATIONS (<math>V_{GS} = 10\text{V}</math>)</b>							
Turn-On Delay Time	$t_{d(ON)}$	$V_{DD} = 15\text{V}$ , $I_D = 14.0\text{A}$ , $V_{GS} = 10\text{V}$ , $R_{GS} = 5.1\Omega$ (Figures 15, 18, 19)	-	14	-	ns	
Rise Time	$t_r$		-	106	-	ns	
Turn-Off Delay Time	$t_{d(OFF)}$		-	49	-	ns	
Fall Time	$t_f$		-	69	-	ns	
<b>GATE CHARGE SPECIFICATIONS</b>							
Total Gate Charge	$Q_{g(TOT)}$	$V_{GS} = 0\text{V}$ to $10\text{V}$	$V_{DD} = 15\text{V}$ , $I_D = 12.0\text{A}$ , $I_{g(REF)} = 1.0\text{mA}$ , (Figures 13, 16, 17)	-	58	-	nC
Gate Charge at 5V	$Q_{g(5)}$	$V_{GS} = 0\text{V}$ to $5\text{V}$		-	31.5	-	nC
Threshold Gate Charge	$Q_{g(TH)}$	$V_{GS} = 0\text{V}$ to $1\text{V}$		-	3	-	nC
Gate to Source Gate Charge	$Q_{gs}$			-	9.5	-	nC
Gate to Drain "Miller" Charge	$Q_{gd}$			-	12	-	nC
<b>CAPACITANCE SPECIFICATIONS</b>							
Input Capacitance	$C_{ISS}$	$V_{DS} = 25\text{V}$ , $V_{GS} = 0\text{V}$ , $f = 1\text{MHz}$ (Figure 12)	-	3050	-	pF	
Output Capacitance	$C_{OSS}$		-	675	-	pF	
Reverse Transfer Capacitance	$C_{RSS}$		-	285	-	pF	

### Source to Drain Diode Specifications

PARAMETER	SYMBOL	TEST CONDITIONS	MIN	TYP	MAX	UNITS
Source to Drain Diode Voltage	$V_{SD}$	$I_{SD} = 12.0\text{A}$	-	0.79	-	V
Reverse Recovery Time	$t_{rr}$	$I_{SD} = 12.0\text{A}$ , $dI_{SD}/dt = 100\text{A}/\mu\text{s}$	-	33	-	ns
Reverse Recovered Charge	$Q_{RR}$	$I_{SD} = 12.0\text{A}$ , $dI_{SD}/dt = 100\text{A}/\mu\text{s}$	-	32	-	nC

Typical Performance Curves

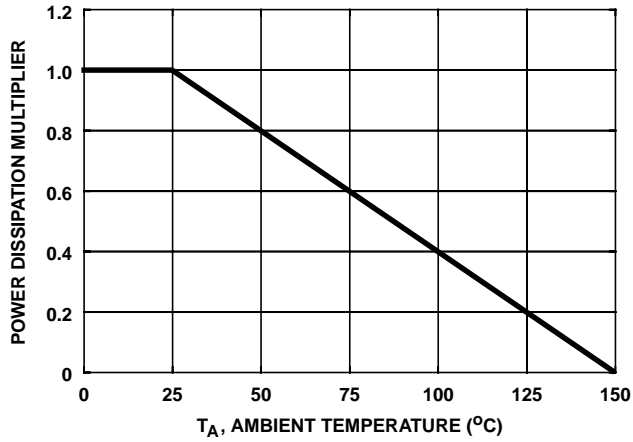

FIGURE 1. NORMALIZED POWER DISSIPATION vs AMBIENT TEMPERATURE

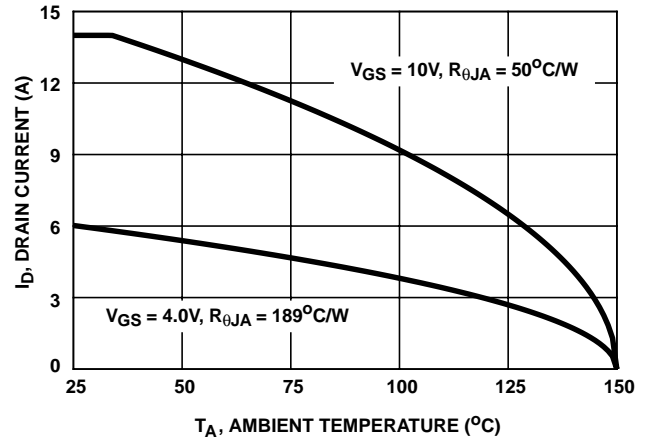

FIGURE 2. MAXIMUM CONTINUOUS DRAIN CURRENT vs AMBIENT TEMPERATURE

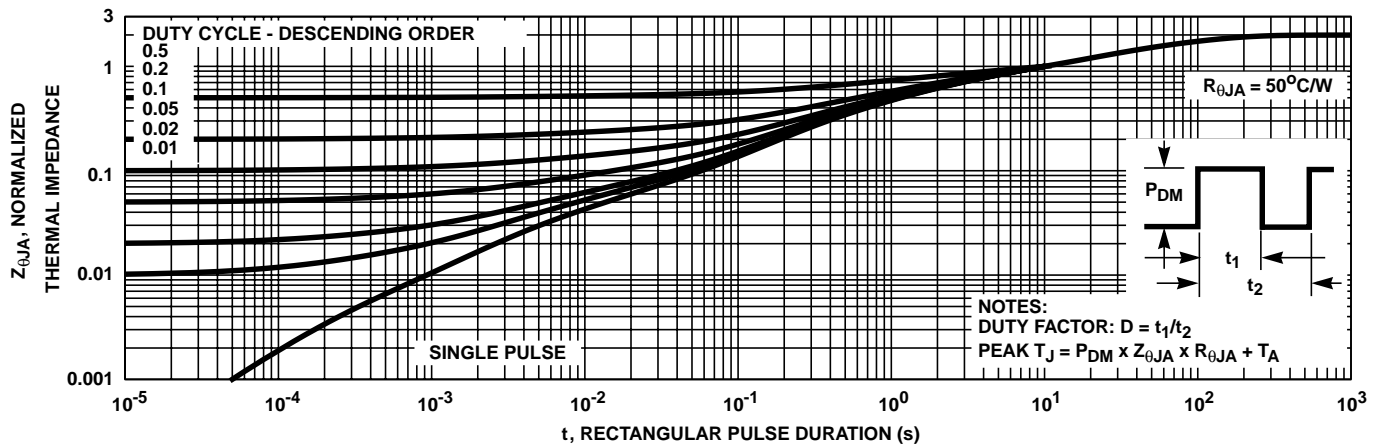

FIGURE 3. NORMALIZED MAXIMUM TRANSIENT THERMAL IMPEDANCE

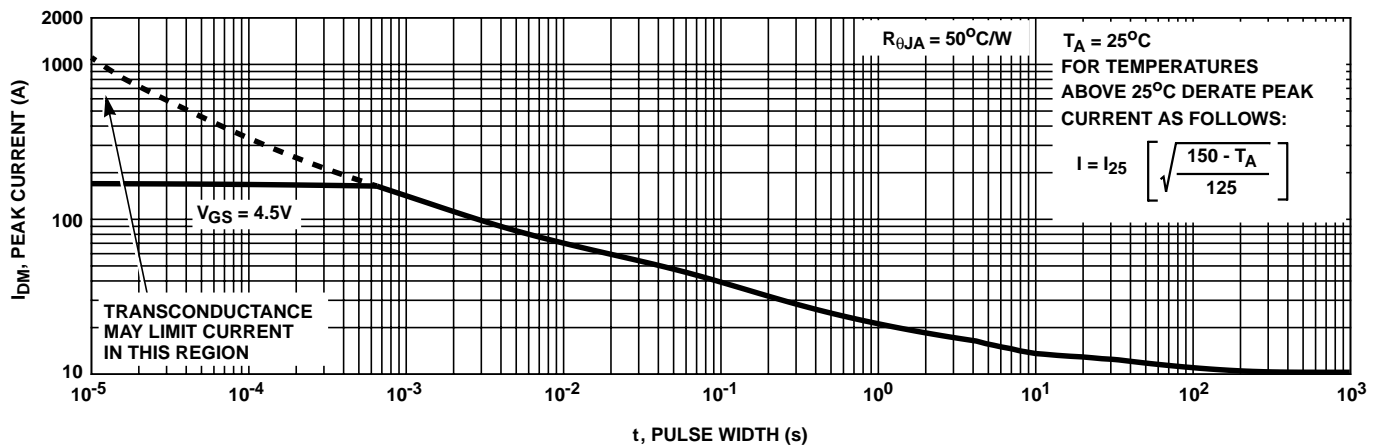

FIGURE 4. PEAK CURRENT CAPABILITY

Typical Performance Curves (Continued)

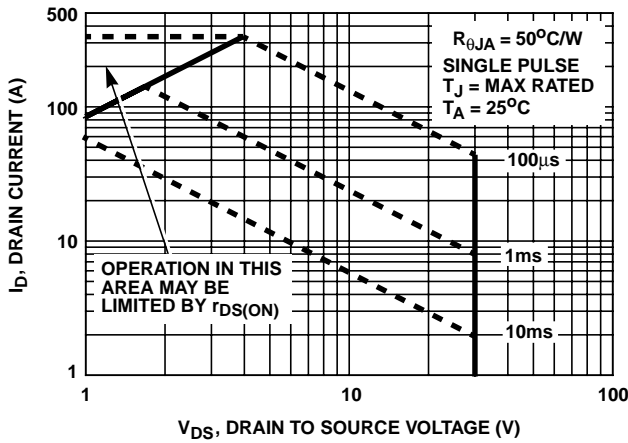

FIGURE 5. FORWARD BIAS SAFE OPERATING AREA

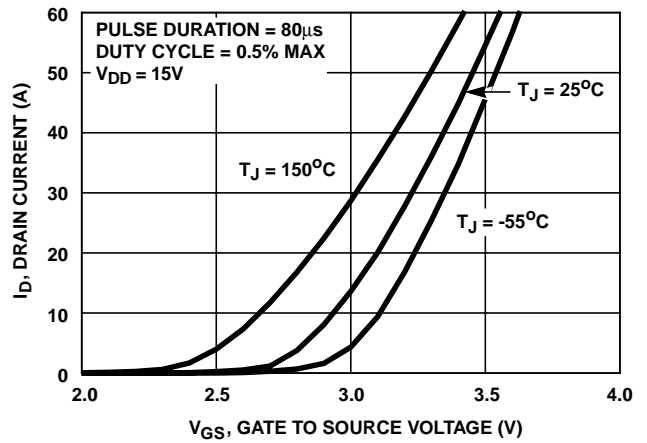

FIGURE 6. TRANSFER CHARACTERISTICS

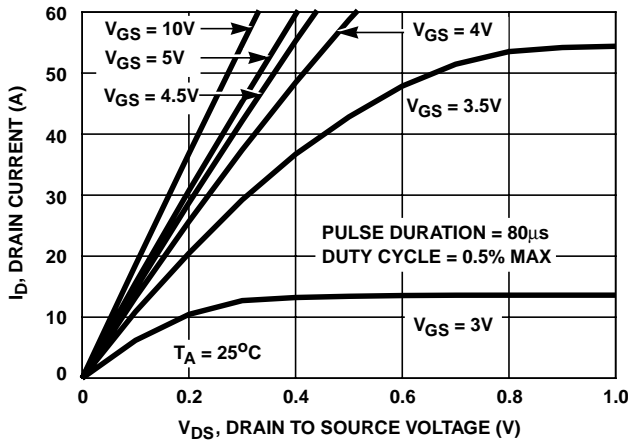

FIGURE 7. SATURATION CHARACTERISTICS

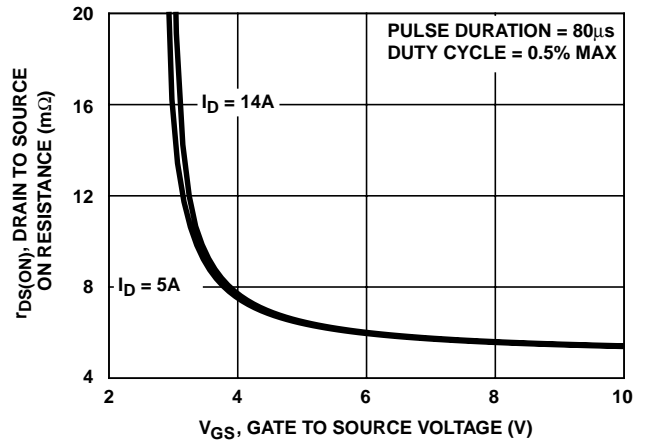

FIGURE 8. DRAIN TO SOURCE ON RESISTANCE vs GATE VOLTAGE AND DRAIN CURRENT

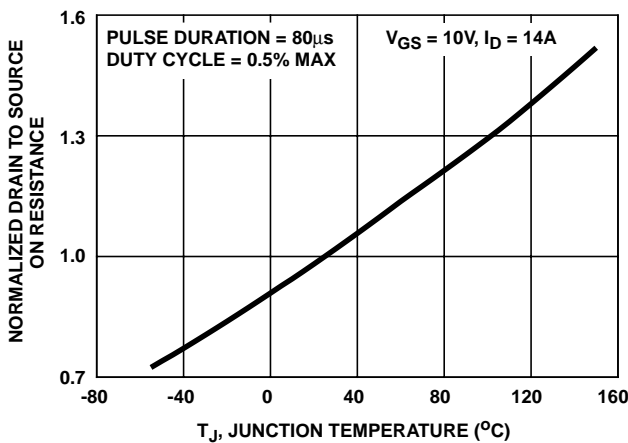

FIGURE 9. NORMALIZED DRAIN TO SOURCE ON RESISTANCE vs JUNCTION TEMPERATURE

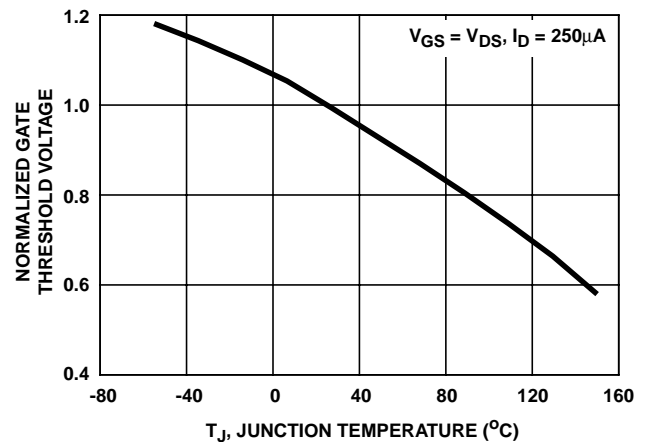

FIGURE 10. NORMALIZED GATE THRESHOLD VOLTAGE vs JUNCTION TEMPERATURE

Typical Performance Curves (Continued)

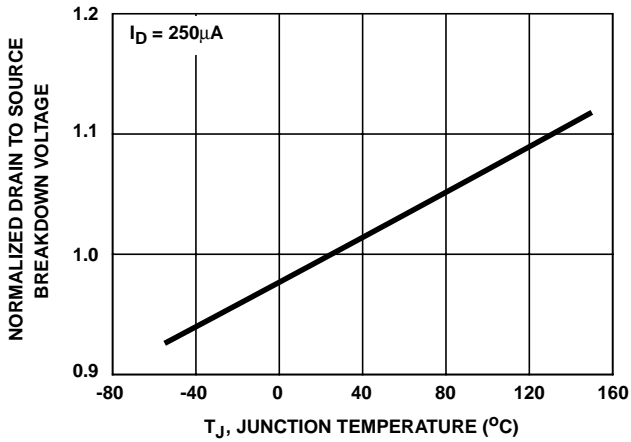

FIGURE 11. NORMALIZED DRAIN TO SOURCE BREAKDOWN VOLTAGE vs JUNCTION TEMPERATURE

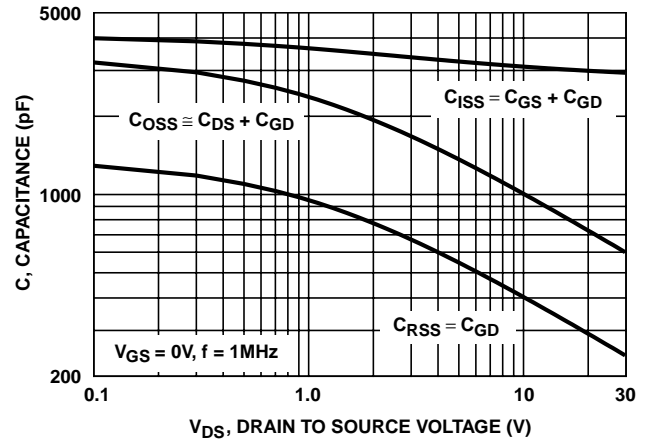
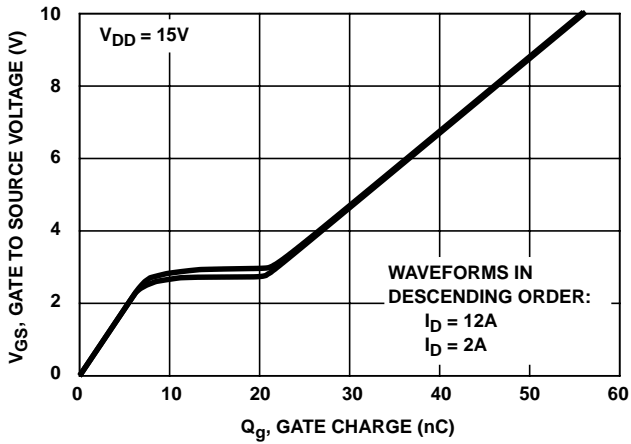

FIGURE 12. CAPACITANCE vs DRAIN TO SOURCE VOLTAGE



NOTE: Refer to Intersil Application Notes AN7254 and AN7260.  
FIGURE 13. GATE CHARGE WAVEFORMS FOR CONSTANT GATE CURRENT

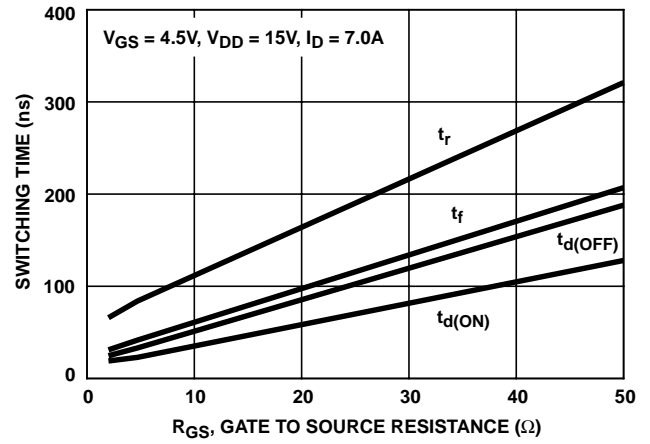

FIGURE 14. SWITCHING TIME vs GATE RESISTANCE

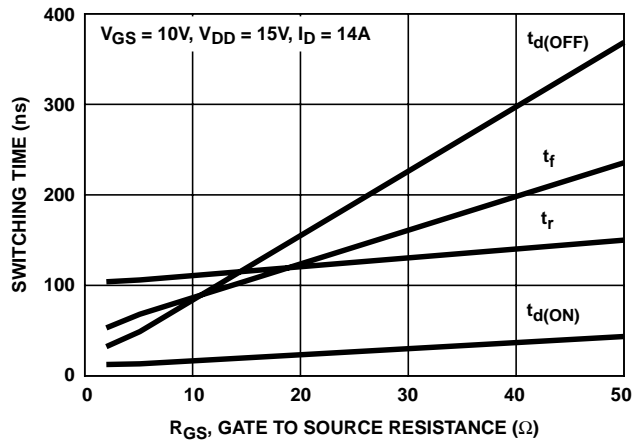

FIGURE 15. SWITCHING TIME vs GATE RESISTANCE

**Test Circuits and Waveforms**

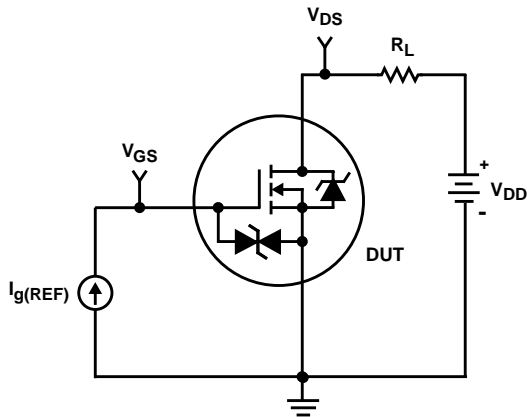

FIGURE 16. GATE CHARGE TEST CIRCUIT

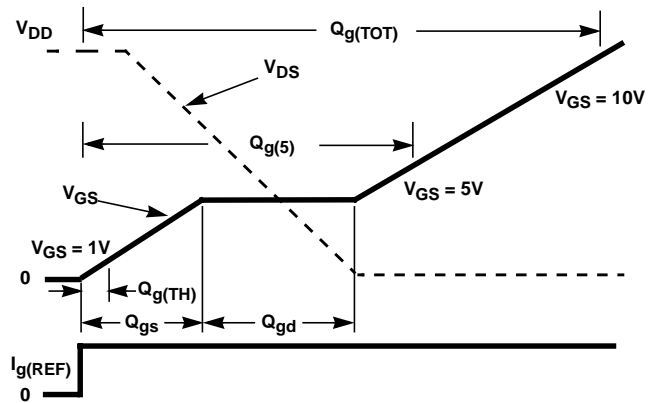

FIGURE 17. GATE CHARGE WAVEFORMS

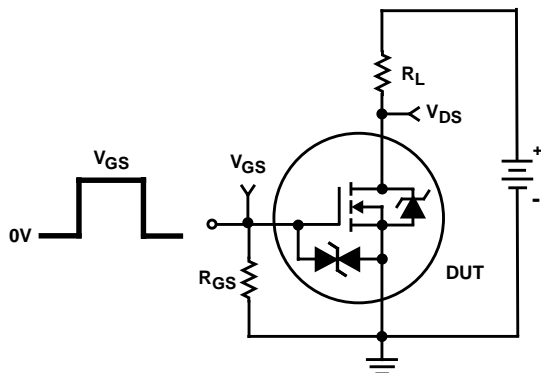

FIGURE 18. SWITCHING TIME TEST CIRCUIT

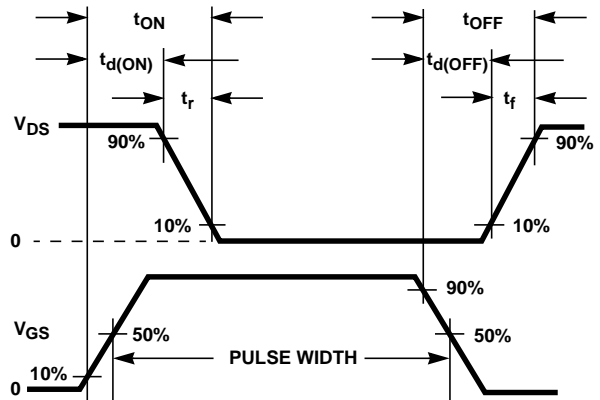

FIGURE 19. SWITCHING TIME WAVEFORM

**Thermal Resistance vs. Mounting Pad Area**

The maximum rated junction temperature,  $T_{JM}$ , and the thermal resistance of the heat dissipating path determines the maximum allowable device power dissipation,  $P_{DM}$ , in an application. Therefore the application's ambient temperature,  $T_A$  ( $^{\circ}C$ ), and thermal resistance  $R_{\theta JA}$  ( $^{\circ}C/W$ ) must be reviewed to ensure that  $T_{JM}$  is never exceeded. Equation 1 mathematically represents the relationship and serves as the basis for establishing the rating of the part.

$$P_{DM} = \frac{(T_{JM} - T_A)}{Z_{\theta JA}} \quad (EQ. 1)$$

In using surface mount devices such as the SO8 package, the environment in which it is applied will have a significant influence on the part's current and maximum power dissipation ratings. Precise determination of  $P_{DM}$  is complex and influenced by many factors:

1. Mounting pad area onto which the device is attached and whether there is copper on one side or both sides of the board.
2. The number of copper layers and the thickness of the board.
3. The use of external heat sinks.
4. The use of thermal vias.
5. Air flow and board orientation.
6. For non steady state applications, the pulse width, the duty cycle and the transient thermal response of the part, the board and the environment they are in.

Intersil provides thermal information to assist the designer's preliminary application evaluation. Figure 20 defines the  $R_{\theta JA}$  for the device as a function of the top copper (component side) area. This is for a horizontally positioned FR-4 board with 1oz copper after 1000 seconds of steady state power with no air flow. This graph provides the necessary information for calculation of the steady state junction temperature or power dissipation. Pulse applications can be evaluated using the Intersil device Spice

## ITF86130SK8T

thermal model or manually utilizing the normalized maximum transient thermal impedance curve.

Displayed on the curve are  $R_{\theta JA}$  values listed in the Electrical Specifications table. The points were chosen to depict the compromise between the copper board area, the thermal resistance and ultimately the power dissipation,  $P_{DM}$ .

Thermal resistances corresponding to other copper areas can be obtained from Figure 20 or by calculation using Equation 2.  $R_{\theta JA}$  is defined as the natural log of the area times a coefficient added to a constant. The area, in square inches is the top copper area including the gate and source pads.

$$R_{\theta JA} = 83.2 - 23.6 \times \ln(\text{Area}) \quad (\text{EQ. 2})$$

The transient thermal impedance ( $Z_{\theta JA}$ ) is also effected by varied top copper board area. Figure 21 shows the effect of copper pad area on single pulse transient thermal impedance. Each trace represents a copper pad area in square inches corresponding to the descending list in the graph. Spice and SABER thermal models are provided for each of the listed pad areas.

Copper pad area has no perceivable effect on transient thermal impedance for pulse widths less than 100ms. For pulse widths less than 100ms the transient thermal impedance is determined by the die and package. Therefore, C THERM1 through C THERM5 and R THERM1 through R THERM5 remain constant for each of the thermal models. A listing of the model component values is available in Table 1.

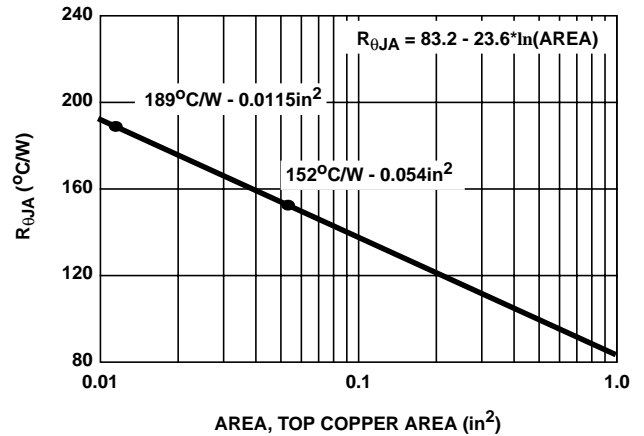

FIGURE 20. THERMAL RESISTANCE vs MOUNTING PAD AREA

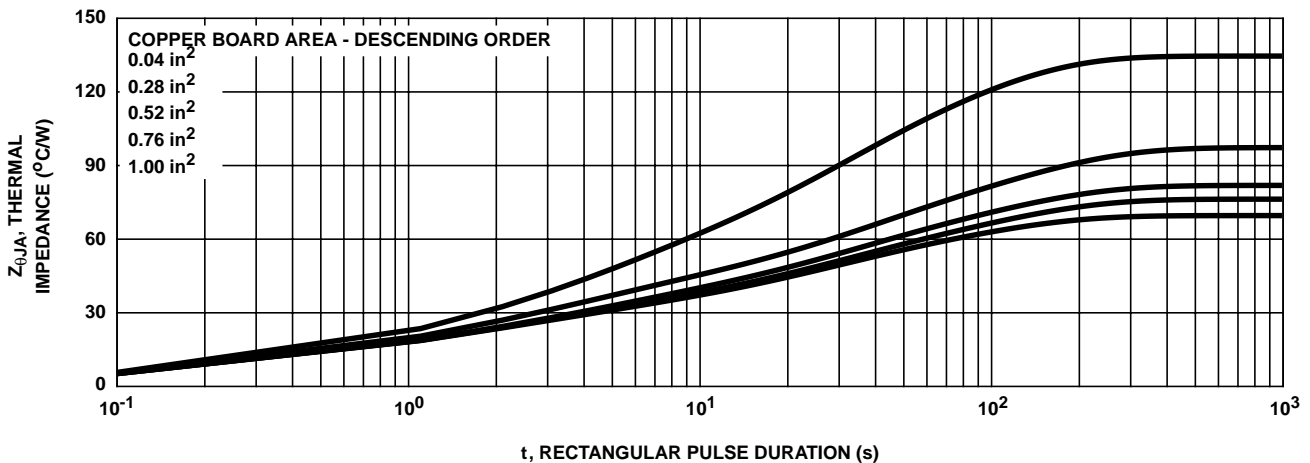

FIGURE 21. THERMAL IMPEDANCE vs MOUNTING PAD AREA

# ITF86130SK8T

## PSPICE Electrical Model

.SUBCKT ITF86130SK8T 2 1 3 ; REV 23 Nov 1999

CA 12 8 2.00e-9  
 CB 15 14 2.15e-9  
 CIN 6 8 2.70e-9

DBODY 7 5 DBODYMOD  
 DBREAK 5 11 DBREAKMOD  
 DESD1 91 9 DESD1MOD  
 DESD2 91 7 DESD2MOD  
 DPLCAP 10 5 DPLCAPMOD

EBREAK 11 7 17 18 37.19  
 EDS 14 8 5 8 1  
 EGS 13 8 6 8 1  
 ESG 6 10 6 8 1  
 EVTHRES 6 21 19 8 1  
 EVTEMP 20 6 18 22 1

IT 8 17 1

LDRAIN 2 5 1.0e-9  
 LGATE 1 9 1.04e-9  
 LSOURCE 3 7 1.29e-10

MMED 16 6 8 8 MMEDMOD  
 MSTRO 16 6 8 8 MSTROMOD  
 MWEAK 16 21 8 8 MWEAKMOD

RBREAK 17 18 RBREAKMOD 1  
 RDRAIN 50 16 RDRAINMOD 3.50e-4  
 RGATE 9 20 1.13  
 RLDRAIN 2 5 10  
 RLGATE 1 9 9 10.4  
 RLSOURCE 3 7 1.29  
 RSLC1 5 51 RSLCMOD 1e-6  
 RSLC2 5 50 1e3  
 RSOURCE 8 7 RSOURCEMOD 4.55e-3  
 RVTHRES 22 8 RVTHRESMOD 1  
 RVTEMP 18 19 RVTEMPMOD 1

S1A 6 12 13 8 S1AMOD  
 S1B 13 12 13 8 S1BMOD  
 S2A 6 15 14 13 S2AMOD  
 S2B 13 15 14 13 S2BMOD

VBAT 22 19 DC 1

ESLC 51 50 VALUE={(V(5,51)/ABS(V(5,51)))\*(PWR(V(5,51))/(1e-6\*650),2))}

.MODEL DBODYMOD D (IS = 4.33e-12 RS = 3.91e-3 TRS1 = 1.01e-3 TRS2 = 1.11e-6 CJO = 2.02e-9 TT = 3.02e-8 M = 0.50)  
 .MODEL DBREAKMOD D (RS = 1.08e-1 TRS1 = 1.01e-3 TRS2 = 1.04e-7)  
 .MODEL DESD1MOD D (BV = 16.4 Tbv1 = -2.50e-3 N = 21 RS = 100)  
 .MODEL DESD2MOD D (BV = 16.1 Tbv1 = -2.50e-3 N = 21 RS = 100)  
 .MODEL DPLCAPMOD D (CJO = 1.35e-9 IS = 1e-30 M = 0.50)  
 .MODEL MMEDMOD NMOS (VTO = 2.28 KP = 10.00 IS = 1e-30 N = 10 TOX = 1 L = 1u W = 1u RG = 1.13)  
 .MODEL MSTROMOD NMOS (VTO = 2.65 KP = 275 IS = 1e-30 N = 10 TOX = 1 L = 1u W = 1u)  
 .MODEL MWEAKMOD NMOS (VTO = 1.92 KP = 0.10 IS = 1e-30 N = 10 TOX = 1 L = 1u W = 1u RG = 11.3 RS = 0.1)  
 .MODEL RBREAKMOD RES (TC1 = 9.98e-4 TC2 = 1.01e-7)  
 .MODEL RDRAINMOD RES (TC1 = 3.78e-2 TC2 = 4.99e-5)  
 .MODEL RSLCMOD RES (TC1 = 4.07e-3 TC2 = 2.25e-5)  
 .MODEL RSOURCEMOD RES (TC1 = 1.00e-3 TC2 = 0)  
 .MODEL RVTHRESMOD RES (TC1 = -2.79e-3 TC2 = -9.65e-6)  
 .MODEL RVTEMPMOD RES (TC1 = -1.90e-3 TC2 = 0)

.MODEL S1AMOD VSWITCH (RON = 1e-5 ROFF = 0.1 VON = -4.0 VOFF = -0.6)  
 .MODEL S1BMOD VSWITCH (RON = 1e-5 ROFF = 0.1 VON = -0.6 VOFF = -4.0)  
 .MODEL S2AMOD VSWITCH (RON = 1e-5 ROFF = 0.1 VON = -0.5 VOFF = 0)  
 .MODEL S2BMOD VSWITCH (RON = 1e-5 ROFF = 0.1 VON = 0 VOFF = -0.5)

.ENDS

NOTE: For further discussion of the PSPICE model, consult **A New PSPICE Sub-Circuit for the Power MOSFET Featuring Global Temperature Options**; IEEE Power Electronics Specialist Conference Records, 1991, written by William J. Hepp and C. Frank Wheatley.

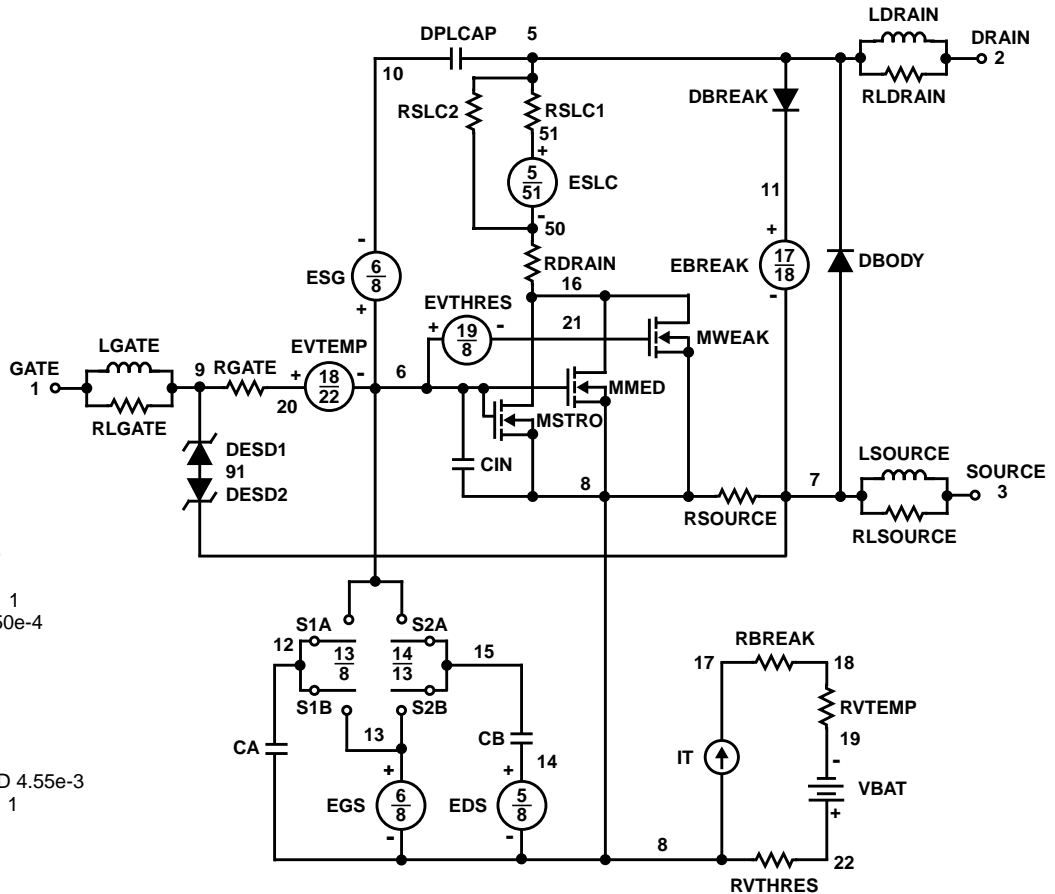



## SABER Electrical Model

REV 23 Nov 1999

template ITF86130SK8T n2,n1,n3  
electrical n2,n1,n3

```

{
var i iscl
dp..model dbodymod = (is = 4.33e-12,rs=3.91e-3,trs1=1.01e-3,trs2=1.11e-6, cjo = 2.02e-9, tt = 3.02e-8, m = 0.50)
dp..model dbreakmod = (rs=1.08e-1,trs1=1.01e-3,trs2=1.04e-7)
dp..model desd1mod = (bv=16.4,tbv1=-2.50e-3,n1=21, rs=100)
dp..model desd2mod = (bv=16.1,tbv1=-2.50e-3,n1=21, rs=100)
dp..model dplcapmod = (cjo = 1.35e-9, is = 1e-30, m = 0.50)
m..model mmedmod = (type=_n, vto = 2.28, kp = 10, is = 1e-30, tox = 1)
m..model mstrongmod = (type=_n, vto = 2.65, kp = 275, is = 1e-30, tox = 1)
m..model mweakmod = (type=_n, vto = 1.92, kp = 0.10, is = 1e-30, tox = 1)
sw_vcsp..model s1amod = (ron = 1e-5, roff = 0.1, von = -4.0, voff = -0.6)
sw_vcsp..model s1bmod = (ron = 1e-5, roff = 0.1, von = -0.6, voff = -4.0)
sw_vcsp..model s2amod = (ron = 1e-5, roff = 0.1, von = -0.5, voff = 0)
sw_vcsp..model s2bmod = (ron = 1e-5, roff = 0.1, von = 0, voff = -0.5)

```

```

c.ca n12 n8 = 2.00e-9
c.cb n15 n14 = 2.15e-9
c.cin n6 n8 = 2.70e-9

```

```

dp.dbody n7 n5 = model=dbodymod
dp.dbreak n5 n11 = model=dbreakmod
dp.desd1 n91 n9 = model=desd1mod
dp.desd2 n91 n7 = model=desd2mod
dp.dplcap n10 n5 = model=dplcapmod

```

```
i.it n8 n17 = 1
```

```

l.l drain n2 n5 = 1.00e-9
l.l gate n1 n9 = 1.04e-9
l.l source n3 n7 = 1.29e-10

```

```

m.mmed n16 n6 n8 n8 = model=mmedmod, l=1u, w=1u
m.mstrong n16 n6 n8 n8 = model=mstrongmod, l=1u, w=1u
m.mweak n16 n21 n8 n8 = model=mweakmod, l=1u, w=1u

```

```

res.rbreak n17 n18 = 1, tc1 = 9.98e-4, tc2 = 1.01e-7
res.rdrain n50 n16 = 3.50e-4, tc1 = 3.78e-2, tc2 = 4.99e-5
res.rgate n9 n20 = 1.13
res.rldrain n2 n5 = 10
res.rlgate n1 n9 = 10.4
res.rlsource n3 n7 = 1.29
res.rs1c1 n5 n51 = 1e-6, tc1 = 4.07e-3, tc2 = 2.25e-5
res.rs1c2 n5 n50 = 1e3
res.rsource n8 n7 = 4.55e-3, tc1 = 1.00e-3, tc2 = 0
res.rvtemp n18 n19 = 1, tc1 = -1.90e-3, tc2 = 0
res.rvthres n22 n8 = 1, tc1 = -2.79e-3, tc2 = -9.65e-6

```

```

spe.ebreak n11 n7 n17 n18 = 37.19
spe.eds n14 n8 n5 n8 = 1
spe.egs n13 n8 n6 n8 = 1
spe.esg n6 n10 n6 n8 = 1
spe.evtemp n20 n6 n18 n22 = 1
spe.evthres n6 n21 n19 n8 = 1

```

```

sw_vcsp.s1a n6 n12 n13 n8 = model=s1amod
sw_vcsp.s1b n13 n12 n13 n8 = model=s1bmod
sw_vcsp.s2a n6 n15 n14 n13 = model=s2amod
sw_vcsp.s2b n13 n15 n14 n13 = model=s2bmod

```

```
v.vbat n22 n19 = dc=1
```

```

equations {
i (n51->n50) +=iscl
iscl: v(n51,n50) = (((v(n5,n51))/(1e-9+abs(v(n5,n51))))*((abs(v(n5,n51))*1e6/650)** 2))
}
}

```

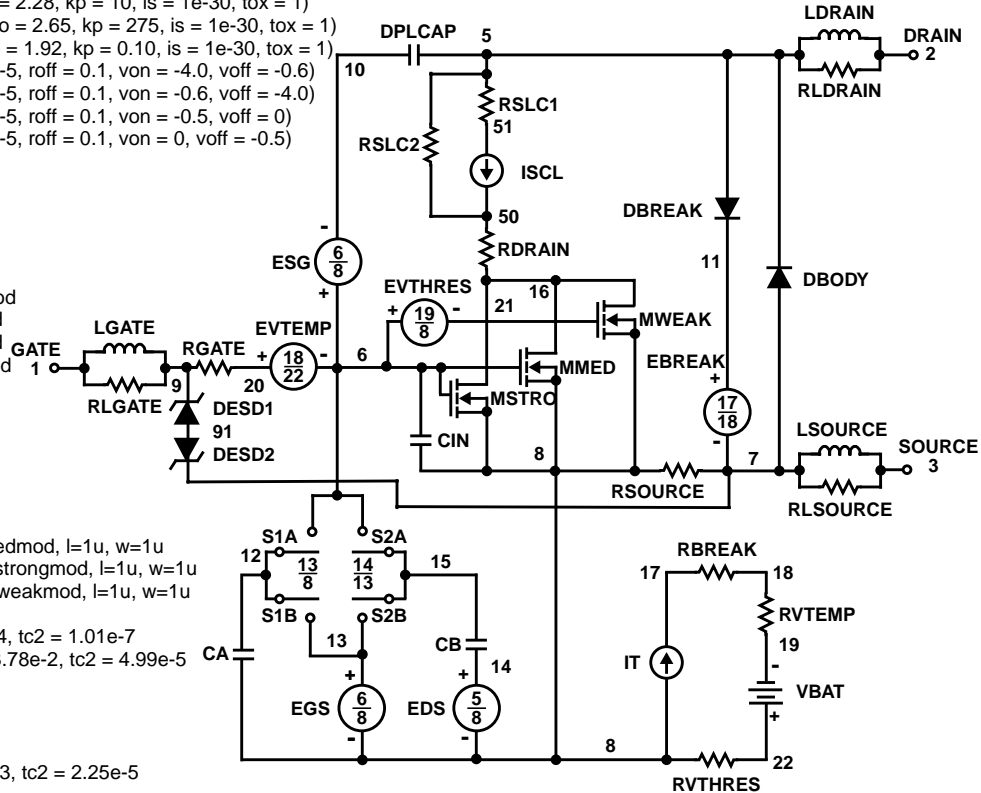

# ITF86130SK8T

## SPICE Thermal Model

REV 11 Nov 1999

ITF86130SK8T

Copper Area = 0.04 in<sup>2</sup>

CTHERM1 th 8 2.0e-3

CTHERM2 8 7 5.0e-3

CTHERM3 7 6 1.0e-2

CTHERM4 6 5 4.0e-2

CTHERM5 5 4 9.0e-2

CTHERM6 4 3 1.2e-1

CTHERM7 3 2 0.5

CTHERM8 2 tl 1.3

RTHERM1 th 8 0.1

RTHERM2 8 7 0.5

RTHERM3 7 6 1.0

RTHERM4 6 5 5.0

RTHERM5 5 4 8.0

RTHERM6 4 3 26

RTHERM7 3 2 39

RTHERM8 2 tl 55

## SABER Thermal Model

Copper Area = 0.04 in<sup>2</sup>

template thermal\_model th tl

thermal\_c th, tl

```
{
ctherm.ctherm1 th 8 = 2.0e-3
ctherm.ctherm2 8 7 = 5.0e-3
ctherm.ctherm3 7 6 = 1.0e-2
ctherm.ctherm4 6 5 = 4.0e-2
ctherm.ctherm5 5 4 = 9.0e-2
ctherm.ctherm6 4 3 = 1.2e-1
ctherm.ctherm7 3 2 = 0.5
ctherm.ctherm8 2 tl = 1.3
```

```
rtherm.rtherm1 th 8 = 0.1
rtherm.rtherm2 8 7 = 0.5
rtherm.rtherm3 7 6 = 1.0
rtherm.rtherm4 6 5 = 5.0
rtherm.rtherm5 5 4 = 8.0
rtherm.rtherm6 4 3 = 26
rtherm.rtherm7 3 2 = 39
rtherm.rtherm8 2 tl = 55
}
```

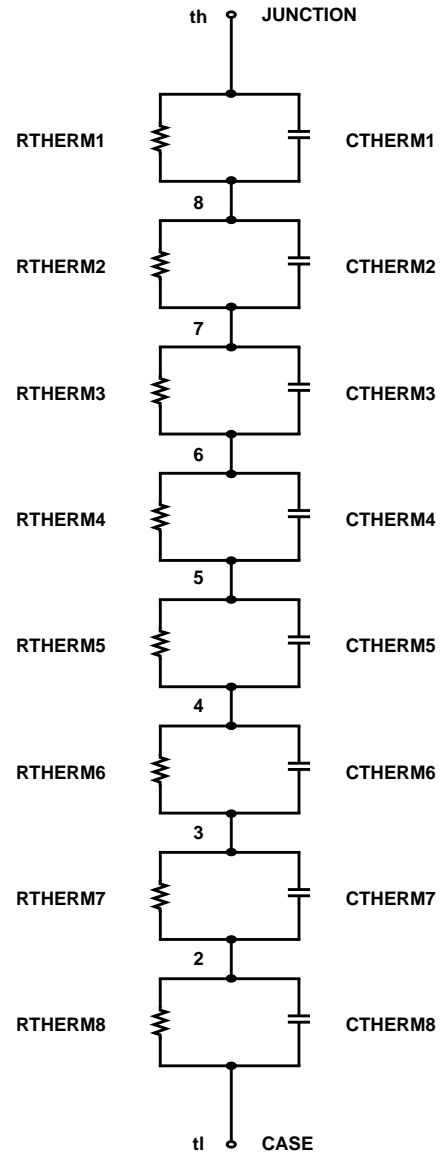

TABLE 1. Thermal Models

COMPONENT	0.04 in <sup>2</sup>	0.28 in <sup>2</sup>	0.52 in <sup>2</sup>	0.76 in <sup>2</sup>	1.0 in <sup>2</sup>
CTHERM6	1.2e-1	1.5e-1	2.0e-1	2.0e-1	2.0e-1
CTHERM7	0.5	1.0	1.0	1.0	1.0
CTHERM8	1.3	2.8	3.0	3.0	3.0
RTHERM6	26	20	15	13	12
RTHERM7	39	24	21	19	18
RTHERM8	55	38.7	31.3	29.7	25

All Intersil semiconductor products are manufactured, assembled and tested under ISO9000 quality systems certification.

Intersil semiconductor products are sold by description only. Intersil Corporation reserves the right to make changes in circuit design and/or specifications at any time without notice. Accordingly, the reader is cautioned to verify that data sheets are current before placing orders. Information furnished by Intersil is believed to be accurate and reliable. However, no responsibility is assumed by Intersil or its subsidiaries for its use; nor for any infringements of patents or other rights of third parties which may result from its use. No license is granted by implication or otherwise under any patent or patent rights of Intersil or its subsidiaries.

For information regarding Intersil Corporation and its products, see web site [www.intersil.com](http://www.intersil.com)

# ITF86130SK8T

## MS-012AA

8 LEAD JEDEC MS-012AA SMALL OUTLINE PLASTIC PACKAGE

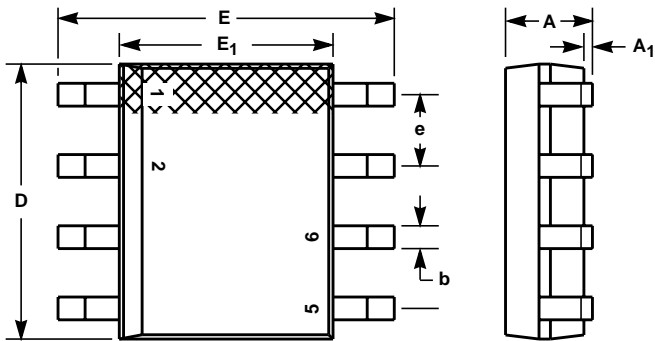

SYMBOL	INCHES		MILLIMETERS		NOTES
	MIN	MAX	MIN	MAX	
A	0.0532	0.0688	1.35	1.75	-
A <sub>1</sub>	0.004	0.0098	0.10	0.25	-
b	0.013	0.020	0.33	0.51	-
c	0.0075	0.0098	0.19	0.25	-
D	0.189	0.1968	4.80	5.00	2
E	0.2284	0.244	5.80	6.20	-
E <sub>1</sub>	0.1497	0.1574	3.80	4.00	3
e	0.050 BSC		1.27 BSC		-
H	0.0099	0.0196	0.25	0.50	-
L	0.016	0.050	0.40	1.27	4

**NOTES:**

- All dimensions are within allowable dimensions of Rev. C of JEDEC MS-012AA outline dated 5-90.
- Dimension "D" does not include mold flash, protrusions or gate burrs. Mold flash, protrusions or gate burrs shall not exceed 0.006 inches (0.15mm) per side.
- Dimension "E<sub>1</sub>" does not include inter-lead flash or protrusions. Inter-lead flash and protrusions shall not exceed 0.010 inches (0.25mm) per side.
- "L" is the length of terminal for soldering.
- The chamfer on the body is optional. If it is not present, a visual index feature must be located within the crosshatched area.
- Controlling dimension: Millimeter.
- Revision 8 dated 5-99.

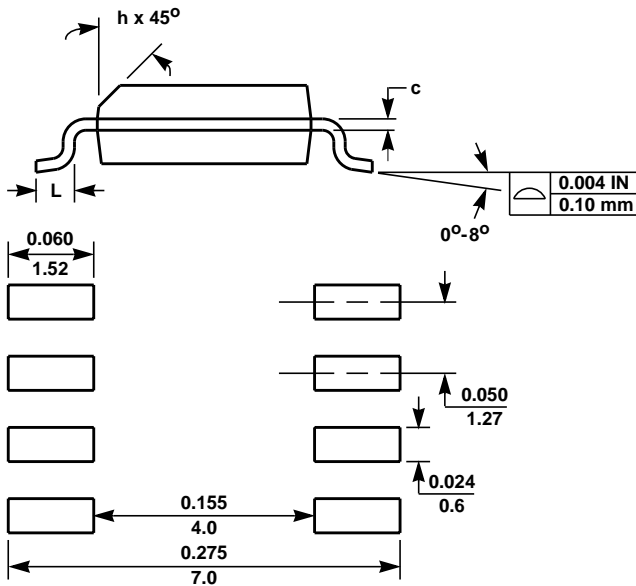

MINIMUM RECOMMENDED FOOTPRINT FOR SURFACE-MOUNTED APPLICATIONS

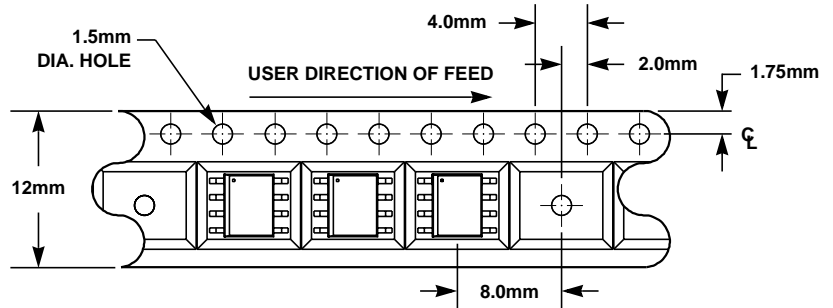

## MS-012AA

12mm TAPE AND REEL

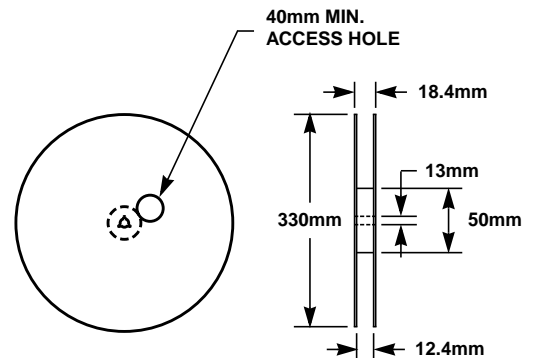
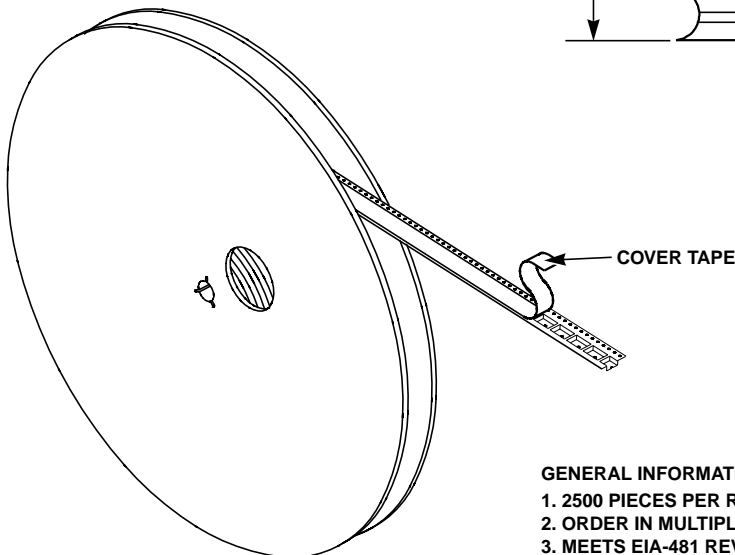

**GENERAL INFORMATION**

- 2500 PIECES PER REEL.
- ORDER IN MULTIPLES OF FULL REELS ONLY.
- MEETS EIA-481 REVISION "A" SPECIFICATIONS.