



查询SC1485ITSTR供应商

# SEMTECH

捷多邦, 专业PCB打样工厂, 24小时加急出货

# SC1485

## Dual Synchronous Buck Pseudo Fixed Frequency Power Supply Controller

### POWER MANAGEMENT

#### Description

The SC1485 is a dual output constant on synchronous-buck PWM controller intended for use in notebook computers and other battery operated portable devices. Features include high efficiency and a fast dynamic response with no minimum on time. The excellent transient response, means that SC1485 based solutions will require less output capacitance than competing fixed frequency converters.

The frequency is constant until a step in load or line voltage occurs at which time the pulse density and frequency will increase or decrease to counter the change in output or input voltage. After the transient event, the controller frequency will return to steady state operation. At light loads, Power-Save Mode enables the SC1485 to skip PWM pulses for better efficiency.

Each output voltage can be independently adjusted from 0.5V to VCCA. Two frequency setting resistors set the on-time for each buck controller. The frequency can thus be tailored to minimize crosstalk. The integrated gate drivers feature adaptive shoot-through protection and soft switching. Additional features include cycle-by-cycle current limit, digital soft-start, over-voltage and under-voltage protection, and a PGOOD output for each controller.

#### Features

- ◆ Constant on-time for fast dynamic response
- ◆ Programmable VOUT range = 0.5 - VCCA
- ◆ VIN Range = 1.8V - 25V
- ◆ DC current sense using low-side RDS(ON) sensing or sense resistor
- ◆ Resistor programmable frequency
- ◆ Cycle-by-cycle current limit
- ◆ Digital soft-start
- ◆ Separate PSAVE option for each switcher
- ◆ Over-voltage/Under-voltage fault protection
- ◆ 10uA Typical shutdown current
- ◆ Low quiescent power dissipation
- ◆ Two PGOOD indicators
- ◆ 1% Reference (2% system DC accuracy)
- ◆ Efficiency >90%
- ◆ Integrated gate drivers with soft switching
- ◆ Separate enables
- ◆ 28 Lead TSSOP
- ◆ Industrial temperature range

#### Applications

- ◆ Notebook computers
- ◆ CPU I/O supplies
- ◆ Handheld terminals and PDAs
- ◆ LCD monitors
- ◆ Network power supplies

#### Typical Application Circuit

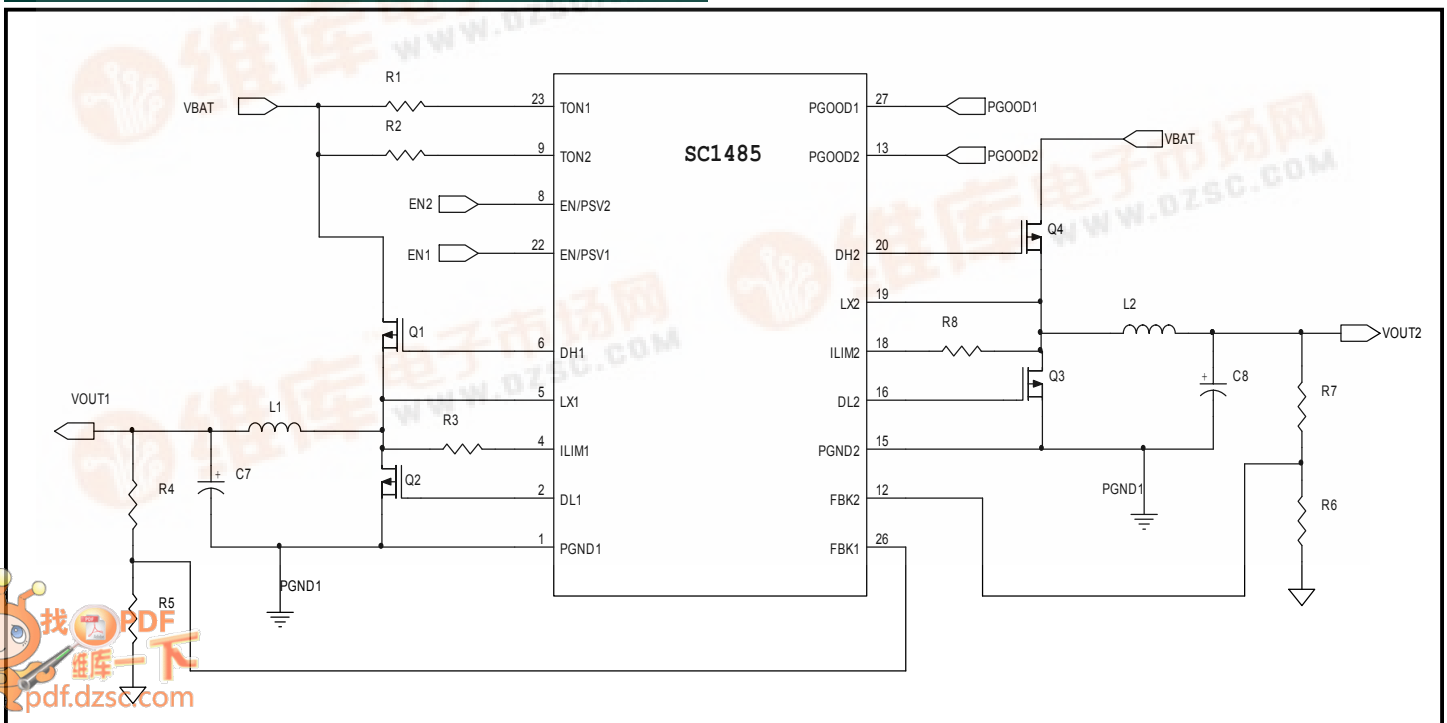

**POWER MANAGEMENT**
**Absolute Maximum Ratings**

Exceeding the specifications below may result in permanent damage to the device, or device malfunction. Operation outside of the parameters specified in the Electrical Characteristics section is not implied.

Parameter	Symbol	Maximum	Units
TON1 to AGND1, TON2 to AGND2		-0.3 to +25.0	V
DH1,BST1 to AGND1 and DH2,BST2 to AGND2		-0.3 to +30.0	V
LX1 to AGND1 and LX2 to AGND2		-2.0 to +25.0	V
AGND1 to PGND1, and AGND2 to PGND2		-0.3 to +0.3	V
BST1 to LX1 and BST2 to LX2		-0.3 to +6.0	V
VCCA1, VDDP1 to AGND1 and VCCA2, VDDP2 to AGND2		-0.3 to +6.0	V
FB1, PGOOD1, EN/PSV1, ILIM1, VOUT1, DL1 to PGND1		-0.3 to +6.0	V
FB2, PGOOD2, EN/PSV2, ILIM2, VOUT2, DL2 to PGND2		-0.3 to +6.0	V
Thermal Resistance Junction to Ambient <sup>(5)</sup>	$\theta_{JA}$	37	°C/W
Operating Junction Temperature Range	$T_J$	-40 to +125	°C
Storage Temperature Range	$T_{STG}$	-65 to +150	°C
Lead Temperature (Soldering) 10 Sec.	$T_{LEAD}$	300	°C

**Electrical Characteristics**

Test Conditions:  $V_{BAT} = 15V$ , EN/PSV1=EN/PSV2 = 5V, VCCA1 = VDDP1 = VCCA2=VDDP2=5.0V,  $V_{OUT1} = 1.25V$ ,  $R_{TON1} = 1M$ ,  $V_{OUT2} = 1.25V$ ,  $R_{TON2} = 1M$

Parameter	Conditions	25°C			-40°C to 125°C		Units
		Min	Typ	Max	Min	Max	
<b>Input Supplies</b>							
VCCA1, VCCA2			5.0		4.5	5.5	V
VDDP1, VDDP2			5.0		4.5	5.5	V
VDDP1, VDDP2 Operating Current	FB > regulation point, $I_{LOAD} = 0A$		1			5	$\mu A$
VCCA1, VCCA2 Operating Current	FB > regulation point, $I_{LOAD} = 0A$		700			1100	$\mu A$
TON1, TON2 Operating Current	$R_{TON} = 1M$ (300kHz)		15				$\mu A$
Shutdown Current	EN/PSV1, EN/PSV2 = 0V		-5			-10	$\mu A$
	VCCA1, VCCA2		5			10	$\mu A$
	VDDP1, TON1, VDDP2, TON2		0			1	$\mu A$
<b>Controller</b>							
Error Comparator Threshold (FBK1, FBK2 turn-on threshold)	VCCA = 4.5V to 5.5V $V_{BAT} = 2V-25V$		0.500		0.495	0.505	V
Output Voltage Range					0.5	VCCA	V

**POWER MANAGEMENT**
**Electrical Characteristics (Cont.)**

 Test Conditions:  $V_{BAT} = 15V$ , EN/PSV1=EN/PSV2 = 5V, VCCA1 = VDDP1 = VCCA2=VDDP2=5.0V,  $V_{OUT1} = 1.25V$ ,  $R_{TON1} = 1M$ ,  $V_{OUT2} = 1.25V$ ,  $R_{TON2} = 1M$ 

Parameter	Conditions	25°C			-40°C to 125°C		Units
		Min	Typ	Max	Min	Max	
On-Time, $V_{BAT} = 2.5V$	$R_{TON} = 1M\Omega$ (300kHz)		1660		1411	1909	ns
	$R_{TON} = 500k\Omega$ (600kHz)		913		776	1050	
Minimum Off Time			400			550	ns
Line Regulation Error	VCCA, VDDP = 4.5V to 5.5V $V_{BAT} = 4.5V$ to 25V		0.04				%/V
Load Regulation Error	ILIM - PGND = 0V to OC Limit EN/PSV = Open		0.3				%
VOUT1, VOUT2 Input Resistance			500				k $\Omega$
FBK1, FBK2 Input Bias Current					-1.0	+1.0	$\mu A$
<b>Over-Current Sensing</b>							
ILIM Current	DL high		10		9	11	$\mu A$
Current Comparator Offset	PGND - ILIM				-10	10	mV
<b>PSAVE</b>							
Zero-Crossing Threshold (PGND - LX)	EN/PSV = 5V		5				mV
<b>Fault Protection</b>							
Current Limit (Positive) <sup>(2)</sup> (PGND - LX)	$R_{ILIM} = 5k\Omega$		50		35	65	mV
	$R_{ILIM} = 10k\Omega$		100		80	120	mV
	$R_{ILIM} = 20k\Omega$		200		170	230	mV
Current Limit (Negative) (PGND-LX)			-140		-200	-100	mV
Output Under-Voltage Fault	With respect to internal reference.		-30		-40	-25	%
Output Over-Voltage Fault	With respect to internal reference.		+10		+8	+12	%
Over-Voltage Fault Delay	FB forced above OV Threshold		2				$\mu s$
PGOOD Low Output Voltage	Sink 1mA					0.4	V
PGOOD Leakage Current	FB in regulation, PGOOD = 5V					1	$\mu A$
PGOOD UV Threshold	With respect to internal reference.		-10		-12	-8	%

**POWER MANAGEMENT**
**Electrical Characteristics (Cont.)**

 Test Conditions:  $V_{BAT} = 15V$ ,  $EN/PSV1=EN/PSV2 = 5V$ ,  $VCCA1 = VDDP1 = VCCA2=VDDP2=5.0V$ ,  $V_{OUT1} = 1.25V$ ,  $R_{TON1} = 1M$ ,  $V_{OUT2} = 1.25V$ ,  $R_{TON2} = 1M$ 

Parameter	Conditions	25°C			-40°C to 125°C		Units
		Min	Typ	Max	Min	Max	
PGOOD Fault Delay	FB forced outside PGOOD window.		2				μs
VCCA Under Voltage Threshold	Falling (100mV Hysteresis )		4.0		3.7	4.3	V
Over Temperature Lockout	10°C Hysteresis		165				°C
<b>Inputs/Outputs</b>							
Logic Input Low Voltage	EN/PSV low					1.2	V
Logic Input High Voltage	EN High, PSV low (Pin Floating)		2.0		1.2	2.4	V
Logic Input High Voltage	EN/PSV high				2.4		V
EN/PSV1 and EN/PSV2	pullup resistance to VCCA		1.5				MΩ
	pulldown resistance to AGND		1.0				
<b>Soft Start</b>							
Soft-Start Ramp Time	EN/PSV high to full current limit.		1.6				ms
Under-Voltage Blank Time	SMPS Turn-On		2				ms
<b>Gate Drivers</b>							
Shoot-Through Delay <sup>(4)</sup>	DH or DL rising		30				ns
DL Pull-Down Resistance	DL low		0.8			1.6	Ω
DL Sink Current	$V_{DL} = 2.5V$		3.1				A
DL Pull-Up Resistance	DL high		2			4	Ω
DL Source Current	$V_{DL} = 2.5V$		1.3				A
DH Pull-Down Resistance	DH low, BST - LX = 5V		2			4	Ω
DH Pull-Up Resistance	DH high, BST - LX = 5V		2			4	Ω
DH Sink/Source Current	$V_{DH} = 2.5V$		1.3				A

**Notes:**

- (1) When the inductor is in continuous and discontinuous conduction mode, the output voltage will have a DC regulation level higher than the error-comparator threshold by 50% of the ripple voltage.
- (2) Using a current sense resistor, this measurement relates to PGND minus the voltage of the source on the low-side MOSFET.
- (3) This device is ESD sensitive. Use of standard ESD handling precautions is required.
- (4) Guaranteed by design. See Shoot-Through Delay Timing Diagram on Page 6.
- (5) Measured in accordance with JESD51-1, JESD51-2 and JESD51-7.

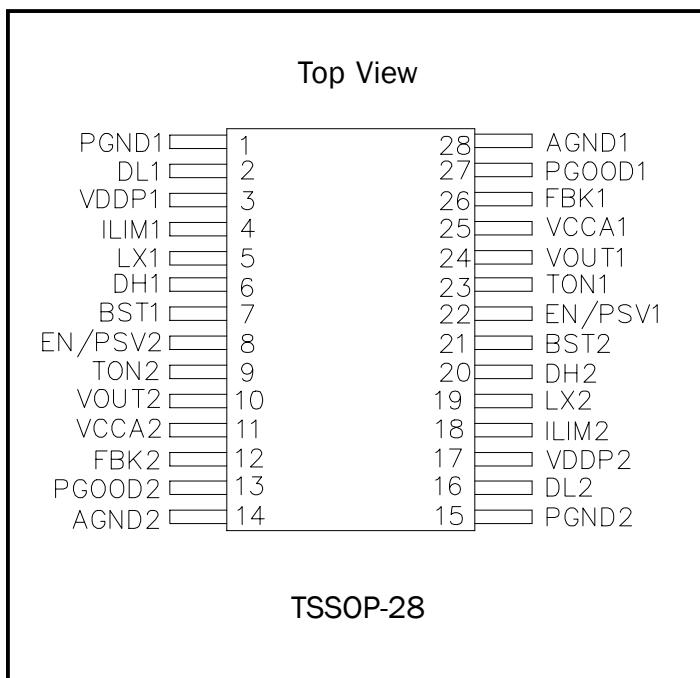
**POWER MANAGEMENT**
**Pin Configuration**

**Ordering Information**

Device	Package <sup>(1)</sup>
SC1485ITSTR	TSSOP-28
SC1485ITSTR <sup>(2)</sup>	TSSOP-28

**Notes:**

(1) Only available in tape and reel packaging. A reel contains 2500 devices.

(2) Lead free product. This product is fully WEEE and RoHS compliant.

**Pin Descriptions**

Pin #	Pin Name	Pin Function
1	PGND1	Power ground.
2	DL1	Gate drive output for the low side MOSFET switch.
3	VDDP1	+5V supply voltage input for the gate drivers.
4	ILIM1	Current limit input pin. Connect to drain of low-side MOSFET for RDS(on) sensing or the source for resistor sensing through a threshold sensing resistor. See applications section for more information.
5	LX1	Switching node inductor connection.
6	DH1	Gate drive output for the high side MOSFET switch.
7	BST1	Boost capacitor connection for the high side gate drive.
8	EN/PSV2	Enable/Power Save input pin. Tie to ground to disable SMPS. Tie to +5V to enable SMPS and activate PSAVE mode. Float to Enable SMPS and activate continuous conduction mode.
9	TON2	Battery input voltage and sets on-time of upper MOSFET by series resistor between input supply and VIN.
10	VOUT2	Output voltage sense input for the SMPS output. Connect to the output of the SMPS.
11	VCCA2	Supply voltage input for the analog supply. Connect through a RC filter.
12	FBK2	Feedback input for the SMPS. Connect from resistive divider at output to select output voltage from 0.5V to VCCA.
13	PGOOD2	Power Good output. Goes high after a fixed clock cycle delay following power up.
14	AGND2	Analog ground.

**POWER MANAGEMENT**

**Pin Descriptions (Cont.)**

15	PGND2	Power ground.
16	DL2	Gate drive output for the low side MOSFET switch.
17	VDDP2	+5V supply voltage input for the gate drivers.
18	ILIM2	Current limit input pin. Connect to drain of low-side MOSFET for RDS(on) sensing or the source for resistor sensing through a threshold sensing resistor. See applications section for more information.
19	LX2	Switching node inductor connection.
20	DH2	Gate drive output for the high side MOSFET switch.
21	BST2	Boost capacitor connection for the high side gate drive.
22	EN/PSV1	Enable/Power Save input pin. Tie to ground to disable SMPS. Tie to +5V to enable SMPS and activate PSAVE mode. Float to Enable SMPS and activate continuous conduction mode.
23	TON1	Battery input voltage and sets on-time of upper MOSFET by series resistor between input supply and VIN.
24	VOUT1	Output voltage sense input for the SMPS output. Connect to the output of the SMPS.
25	VCCA1	Supply voltage input for the analog supply. Connect through a RC filter.
26	FBK1	Feedback input for the SMPS. Connect from resistive divider at output to select output voltage from 0.5V to VCCA.
27	PGOOD1	Power Good output. Goes high after a fixed clock cycle delay following power up.
28	AGND1	Analog ground.

**Shoot-Through Delay Timing Diagram**

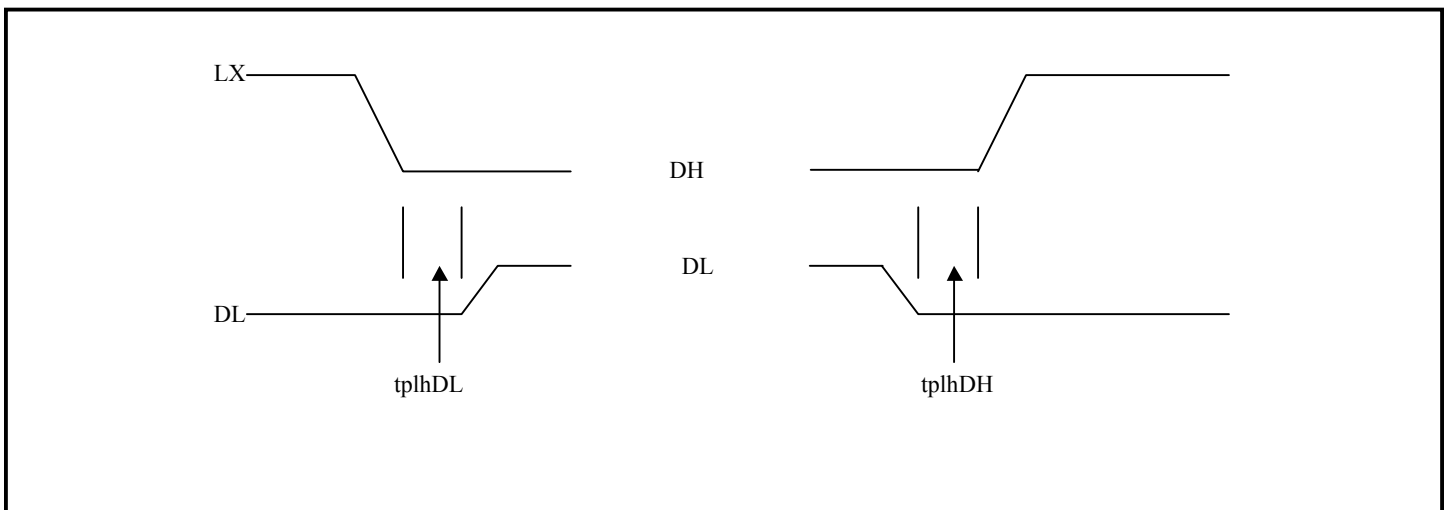

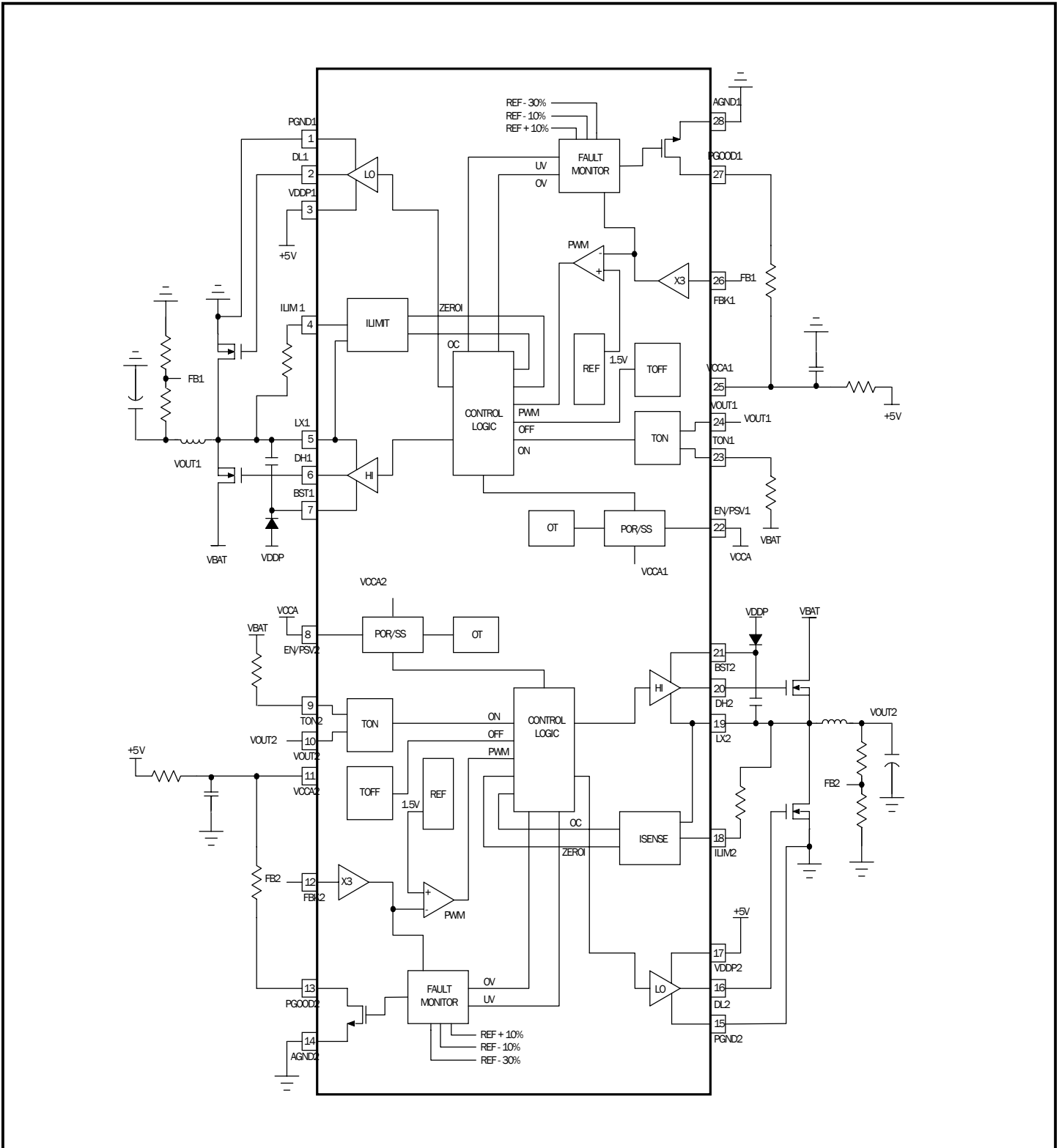
**POWER MANAGEMENT**
**Block Diagram**

**FIGURE 1**

**POWER MANAGEMENT**
**Applications Information**
**+5V Bias Supplies**

The SC1485 requires an external +5V bias supply in addition to the battery. If stand-alone capability is required, the +5V supply can be generated with an external linear regulator such as the Semtech LP2951A. To minimize channel to channel crosstalk, each controller has 4 supply pins, VDDP, PGND, VCCA and AGND.

To avoid ground loops, separate AGND planes are recommended. Each controller requires its own AGND plane which should be tied by a single trace to the negative terminal of that controller's output capacitor. All external components referenced to AGND in the schematic should then be connected to the appropriate AGND plane. The supply decoupling capacitor for controller 1 should be tied between VCCA1 and AGND1. Likewise, the supply decoupling capacitor for controller 2 should be tied between VCCA2 and AGND2. A single 10 ohm resistor should be used to decouple the VCCA supplies from the main VDDP supplies. PGND can then be a separate plane which is not used for routing traces. All PGND connections are connected directly to this plane with special attention given to avoiding indirect connections which may create ground loops. As mentioned above, the two AGND planes must be connected to the PGND plane at the negative terminal of the respective output capacitors.

The VDDP1 and VDDP2 input provides power to the upper and lower gate drivers. A decoupling capacitor for each supply is recommended. No series resistor between VDDP and the 5 volt bias is required.

**Pseudo-fixed Frequency Constant On-Time PWM Controller**

The PWM control architecture consists of a constant-on-time, pseudo fixed frequency PWM controller, (Figure 1). The output ripple voltage developed across the output filter capacitor's ESR provides the PWM ramp signal eliminating the need for a current sense resistor. The high-side switch on-time is determined by a one-shot whose period is directly proportional to output voltage and inversely proportional to input voltage. A second one-shot sets the minimum off-time to 400ns typically.

**On-Time One-Shot ( $T_{ON}$ )**

The on-time one-shot comparator has two inputs. One input looks at the output voltage, while the other input samples the input voltage and converts it to a current.

This input proportional current is used to charge an internal on-time capacitor. The TON time is the time required for the voltage on this capacitor to charge from zero volts to VOUT, thereby making the on-time of the high-side switch directly proportional to output voltage and inversely proportional to input voltage. This implementation results in a nearly constant switching frequency without the need of a clock generator.

$$T_{ON} = 3.3 \times 10^{-12} \cdot (R_{TON} + 37 \times 10^3) \cdot \left( \frac{V_{OUT}}{V_{IN}} \right) + 50ns$$

$R_{TON}$  is a resistor connected from the input supply to the TON pin. The graph on page 16 shows the relationship between  $R_{TON}$  and switching frequency.

**Enable & Psave**

The SC1485 combines the ENABLE and PSAVE functions into a single pin. When the pin is tied to ground the SMPS is disabled. When it is tied to +5V the SMPS is enabled and PSAVE is active. In order to enter PSAVE, The SC1485 PSAVE comparator will look for 8 consecutive inductor current reversals. When this happens, the controller will switch into PSAVE mode. At the same time, the SC1485 will increase the on-time by 1.5 times its set value. This will increase the ripple current and ripple voltage by 1.5 times their continuous conduction mode (CCM) values. This increase has two benefits. First, the reduction in switching frequency will improve efficiency. Second, hysteresis is added to the PSAVE circuit. This is important because when in PSAVE, the very first time a current reversal does not occur, the SC1485 will exit the PSAVE mode. This allows the device to rapidly respond to transient load conditions, while adding hysteresis to eliminate false PSAVE exits.

When the pin is left floating, the pin is internally pulled to 2V, enabling the SMPS in CCM.

**Output Voltage Selection**

The output voltage selection is set by the feedback resistors R2 & R3 of Figure 3. The internal reference is 1.5V. The internal feedback pin is multiplied by three to match the 1.5V reference. Therefore the output can be selected to a minimum of 0.5V. The equation for selecting the output voltage based on Figure 3 is:

$$V_{OUT} = \left( 1 + \frac{R2}{R3} \right) \cdot 0.5$$



POWER MANAGEMENT

Applications Information (Cont.)

**Current Limit Circuit**

Current limiting of the SC1485 can be accomplished in two ways. First, the device can implement on-state resistance of the low-side MOSFET as the current sensing element ( $R_{DS_{ON}}$  sensing). Second, the device can accept a resistive element in the low-side source ( $R_{SENSE}$  resistor sensing). The second method offers greater accuracy of the current limit threshold over  $R_{DS_{ON}}$  sensing, at the added expense of a sense resistor and associated efficiency loss.

Whether  $R_{DS_{ON}}$  sensing or  $R_{SENSE}$  resistor sensing is used, a scaling resistor between LX and ILIM is required. This resistor,  $R_{ILIM}$ , is connected to a 10uA current source within the SC1485 through the ILIM pin. This sets a voltage drop equal to 10uA times  $R_{ILIM}$ . As the current increases through the lower MOSFET, the phase pin voltage will decrease until the offset voltage caused by  $R_{ILIM}$  is reached and  $ILIM < PGND$ . At this point an over-current trip signal is issued. Current limiting will prevent the firing of a DH on-pulse, thereby reducing the switching frequency. As the frequency decreases, the output voltage will drop until an under-voltage shutdown is reached. The current sensing circuit actually limits the inductor valley current (see Figure 2). This means that if the current limit is set to 10A, the peak current through the inductor would be 10A plus the peak ripple current, and the average current through the inductor would be 10A plus 1/2 the peak-to-peak ripple current. The equations for setting the valley current and calculating the average current through the inductor are shown below:

$$I_{L_{OC}}(\text{Valley}) = 10\mu A \cdot \frac{R_{ILIM}}{R_{DS_{ON}}}$$

$$I_{L_{OC}}(\text{Average}) = I_{L_{OC}}(\text{Valley}) + \frac{\Delta I_L}{2}$$

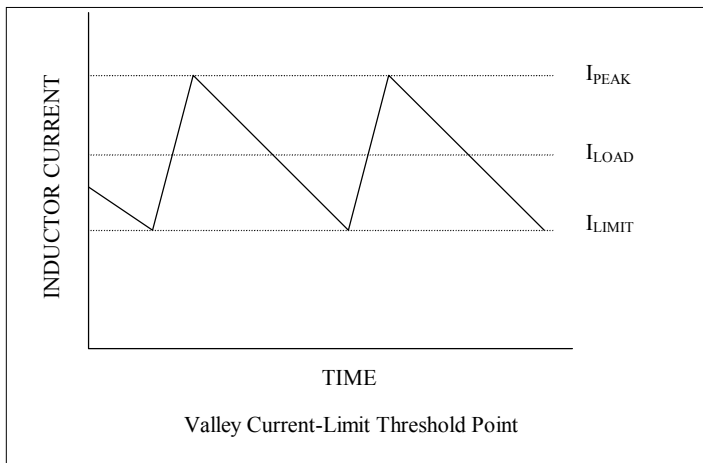

FIGURE 2

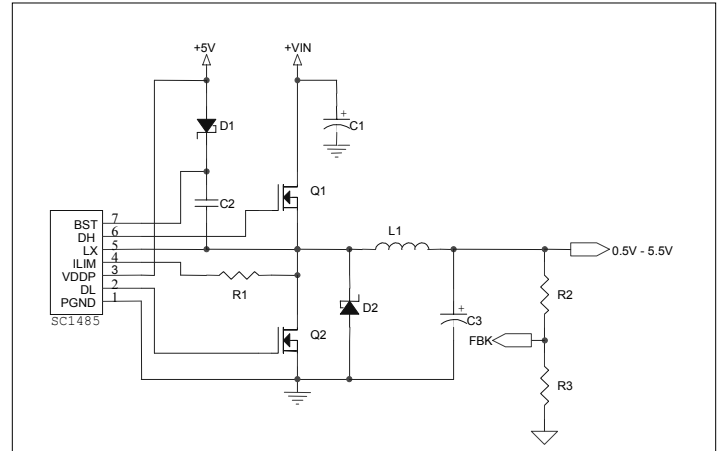

FIGURE 3

The schematic of  $R_{DS_{ON}}$  sensing circuit is shown in Figure 3 with  $R_{ILIM} = R1$  and  $R_{DS_{ON}}$  of Q2.

Similarly, for resistor sensing, the current through the lower MOSFET and the source sense resistor develops a voltage that opposes the voltage developed across  $R_{ILIM}$ . When the voltage developed across the  $R_{SENSE}$  resistor reaches voltage drop across  $R_{ILIM}$ , an over-current exists and the high side MOSFET will not be allowed to turn on. The over-current equation when using an external sense resistor is:

$$I_{L_{OC}}(\text{Valley}) = 10\mu A \cdot \frac{R_{ILIM}}{R_{SENSE}}$$

Schematic of resistor sensing circuit is shown in Figure 4 with  $R_{ILIM} = R1$  and  $R_{SENSE} = R4$ .

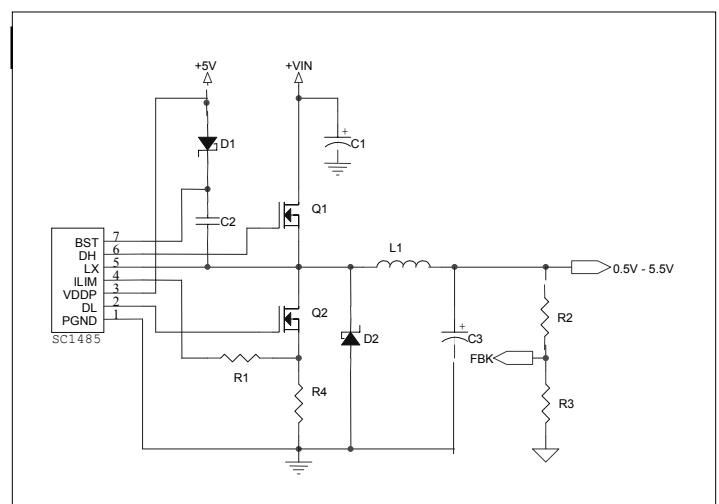

FIGURE 4

**POWER MANAGEMENT****Applications Information****Power Good Output**

Power good is an open-drain output and requires a pull-up resistor. When the output voltage is 10% above or below its set voltage, PGOOD gets pulled low. It is held low until the output voltage returns to within 10% of the output set voltage. PGOOD is also held low during start-up and will not be allowed to transition high until the output reaches 90% of its set voltage. There is a slight delay built into the PGOOD circuit to prevent false transitions.

**Output Overvoltage Protection**

When the output exceeds 10% of its set voltage the low-side MOSFET is latched on. It stays latched and the SMPS is off until the enable input or POR is toggled. There is a slight delay built into the OV protection circuit to prevent false transitions.

**Output Undervoltage Protection**

When the output is 30% below its set voltage the output is latched in a tristated condition, and the SMPS is off until the enable input or POR is toggled. There is a slight delay built into the UV protection circuit to prevent false transitions.

**POR, UVLO and Softstart**

An internal power-on reset (POR) occurs when VCCA exceeds 3V, resetting the fault latch and soft-start counter, and preparing the PWM for switching. VCCA undervoltage lockout (UVLO) circuitry inhibits switching and forces the DL gate driver high until VCCA rises above 4.1V. At this time the circuit will come out of UVLO and begin switching, and the softstart circuit being enabled, will progressively limit the output current over a predetermined time period. The ramp occurs in four steps: 25%, 50%, 75% and 100%, thereby limiting the slew rate of the output voltage. There is 100mV of hysteresis built into the UVLO circuit and when the VCCA falls to 4.0V the output drivers are shutdown and tristated.

**MOSFET Gate Drivers**

The DH and DL drivers are optimized for driving moderate-sized high-side, and larger low-side power MOSFETs. An adaptive dead-time circuit monitors the DL output and prevents the high-side MOSFET from turning on, until DL is fully off, and conversely, monitors the DH output and prevents the low-side MOSFET from turning on until DH is fully off. Be sure there is low resistance and low inductance between the DH and DL outputs to the gate of each MOSFET.

The high-side gate driver is equipped with turn-on soft switching to reduce gate drive power dissipation. When a DH turn-on is initiated the pull-up resistance is 10 ohms. This limits the peak high-side gate current before the MOSFET is conducting current. The peak gate current plays a large role in gate driver switching losses. When the high-side MOSFET begins conducting, and LX starts to rise, the pull-up resistance on DH changes to 2 ohms.

**Design Procedure**

Prior to any design of a switch mode power supply (SMPS) for notebook computers, determination of input voltage, load current, switching frequency and inductor ripple current must be specified.

**Input Voltage Range**

The maximum input voltage ( $V_{IN,MAX}$ ) is determined by the highest AC adaptor voltage. The minimum input voltage ( $V_{IN,MIN}$ ) is determined by the lowest battery voltage after accounting for voltage drops due to connectors, fuses and battery selector switches.

**Maximum Load Current**

There are two values of load current to consider. Continuous load current and peak load current. Continuous load current has more to do with thermal stresses and therefore drives the selection of input capacitors, MOSFETs and commutation diodes. Whereas, peak load current determines instantaneous component stresses and filtering requirements such as, inductor saturation, output capacitors and design of the current limit circuit.

**Switching Frequency**

Switching frequency determines the trade-off between size and efficiency. Increased frequency increases the switching losses in the MOSFETs, since losses are a function of  $V_{IN}^2$ . Knowing the maximum input voltage and budget for MOSFET switches usually dictates where the design ends up.

**Inductor Ripple Current**

Low inductor values create higher ripple current, resulting in smaller size, but are less efficient because of the high AC currents flowing through the inductor. Higher inductor values do reduce the ripple current and are more efficient, but are larger and more costly. The selection of the ripple current is based on the maximum output current and tends to be between 20% to 50% of the maximum load current. Again, cost, size and efficiency all play a part in the selection process.

POWER MANAGEMENT

Applications Information (Cont.)

**Stability Considerations**

Unstable operation shows up in two related but distinctly different ways: double pulsing and fast-feedback loop instability.

Double-pulsing occurs due to noise on the output or because the ESR is too low, causing not enough voltage ramp in the output signal. This causes the error amplifier to trigger prematurely after the 400ns minimum off-time has expired. Double-pulsing will result in higher ripple voltage at the output, but in most cases is harmless. However, in some cases double-pulsing can indicate the presence of loop instability, which is caused by insufficient ESR. One simple way to solve this problem is to add some trace resistance in the high current output path. A side effect of doing this is output voltage droop with load. Another way to eliminate doubling-pulsing is to add a 10pF capacitor across the upper feedback resistor divider network. This is shown below in Figure 5, by capacitor C4 in the schematic. This capacitance should be left out until confirmation that double-pulsing exists. Adding this capacitance will add a zero in the transfer function and should eliminate the problem. It is best to leave a spot on the PCB in case it is needed.

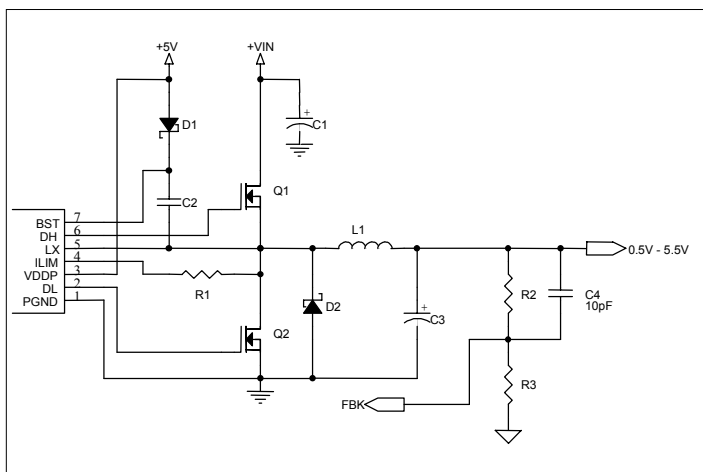

FIGURE 5

Loop instability can result in oscillations at the output after line or load perturbations that can trip the overvoltage protection latch or cause the output voltage to fall below the tolerance limit.

The best way for checking stability is to apply a zero to full load transient and observe the output voltage ripple envelope for overshoot and ringing. Over one cycle of ringing after the initial step is sign that the ESR should be increased.

**SC1485 ESR Requirements**

The constant on-time control used in the SC1485 regulates the ripple voltage at the output capacitor. This signal consists of a term generated by the output ESR of the capacitor and a term based on the increase in voltage across the capacitor due to charging and discharging during the switching cycle. The minimum ESR is set to generate the required ripple voltage for regulation. For most applications the minimum ESR ripple voltage is dominated by PCB layout and the properties of SP or POSCAP type output capacitors. For applications using ceramic output capacitors the absolute minimum ESR must be considered. Existing literature describing the ESR requirements to prevent double pulsing does not accurately predict the performance of constant on-time controllers. A time domain model of the converter was developed to generate equations for the minimum ESR empirically. If the ESR is low enough the ripple voltage is dominated by the charging of the output capacitor. This ripple voltage lags the on-time due to the LC poles and can cause double pulsing if the phase delay exceeds the off-time of the converter. Referring to Figure 5, the equation for the minimum ESR as a function of output capacitance and switching frequency and duty cycle is;

$$ESR > \left( \frac{R2+R3}{R3} \right) \cdot \left( \frac{1+3 \cdot \left( \frac{Fs-200000}{Fs} \right)}{2 \cdot \pi \cdot Cout \cdot Fs \cdot (1-D)^2} \right)$$

Where D = Vout/Vin.

**POWER MANAGEMENT**
**Applications Information (Cont.)**

**Layout Guidelines** - see Application Note AN02-6

**1485 System DC Accuracy**

Three IC parameters affect system DC accuracy, the internal band gap reference, the error comparator offset voltage, and the switching frequency variation with line and load.

The internal 1% 1.5V reference contains two error components, a 0.5% DC error and a 0.5% supply and temperature error. The error comparator offset is trimmed so that it trips when the feedback pin is nominally 0.5 volts +/-1% at room temperature. The comparator offset trim compensates for any DC error in the reference. Thus, the percentage error is the sum of the reference variation over supply and temperature and the offset in the error comparator or 1.5%.

The on pulse in the SC1485 is calculated to give a pseudo fixed frequency. Nevertheless, some frequency variation with line and load can be expected. This variation changes the output ripple voltage. Because constant on regulators regulate to the valley of the output ripple, ½ of the output ripple appears as a DC regulation error. For example, if the feedback resistors are chosen to divide down the output by a factor of five, the valley of the output ripple will be 2.5V. If the ripple is 50mv with VIN = 6 volts, then the measured DC output will be 2.525 volts. If the ripple increases to 80mv with VIN = 25 volts, then the measured DC output will be 2.540. The best way to minimize this effect is to minimize the output ripple.

To compensate for valley regulation is usually desirable to use passive droop. Take the feedback directly from the output side of the inductor incorporating a small amount of trace resistance between the inductor and output capacitor. This trace resistance should be optimized so that at full load the output droops to near the lower regulation limit. Passive droop minimizes the required output capacitance because the voltage excursions due to load steps are reduced.

Board components and layout also influence DC accuracy. The use of 1% feedback resistors contribute 1%. If tighter DC accuracy is required use 0.1% feedback resistors.

The output inductor value may change with current. This will change the output ripple and thus the DC output voltage. It will not change the frequency.

Switching frequency variation with load can be minimized by choosing lower RDSON MOSFETs. High RDSON MOSFETS will cause the switching frequency to increase as the load current increases. This will reduce the ripple and thus the DC output voltage. This inherent droop should be considered when deciding if passive droop is required. If the output ripple some passive droop may be desirable to further reduce the output capacitance.

**Thermal Considerations**

The junction temperature of the device may be calculated as follows:

$$T_J = T_A + P_D \cdot \theta_{JA} \quad ^\circ\text{C}$$

Where:

$T_A$  = ambient temperature ( $^\circ\text{C}$ )

$P_D$  = power dissipation in (W)

$\theta_{JA}$  = thermal impedance junction to ambient from absolute maximum ratings ( $^\circ\text{C}/\text{W}$ )

The power dissipation may be calculated as follows:

$$P_D = 2 \cdot (V_{CCA} \cdot I_{V_{CCA}} + V_g \cdot Q_g \cdot f) \quad \text{W}$$

Where:

$V_{CCA}$  = chip supply voltage (V)

$I_{V_{CCA}}$  = operating current (A)

$V_g$  = gate drive voltage, typically 5V (V)

$Q_g$  = FET gate charge, from the FET datasheet (C)

$f$  = switching frequency (kHz)

Inserting the following values as an example:

$$T_A = 85^\circ\text{C}$$

$$\theta_{JA} = 37^\circ\text{C}/\text{W}$$

$$V_{CCA} = 5\text{V}$$

$$I_{V_{CCA}} = 1100\mu\text{A} \text{ (data sheet maximum)}$$

$$V_g = 5\text{V}$$

$$Q_g = 60\text{nC}$$

$$f = 300\text{kHz} \text{ (enter the higher of the two set frequencies here)}$$

gives us:

$$T_J = 85 + 2 \cdot (5 \cdot 1100 \cdot 10^{-6} + 5 \cdot 60 \cdot 10^{-9} \cdot 300 \cdot 10^3) \cdot 37 = 92 \quad ^\circ\text{C}$$

As can be seen, the heating effects due to internal power dissipation are practically negligible, thus requiring no special consideration thermally during layout.

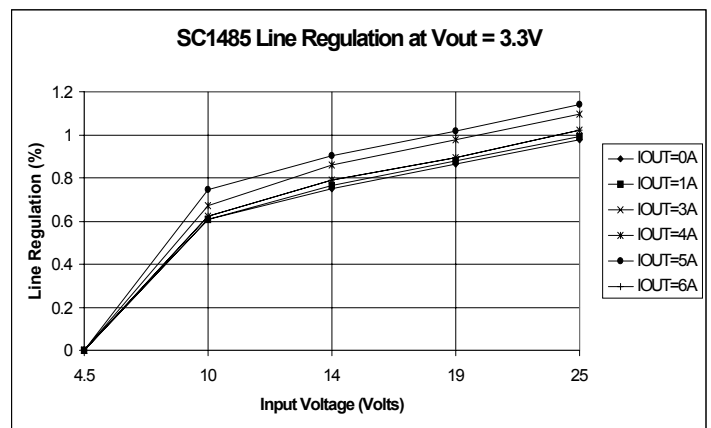
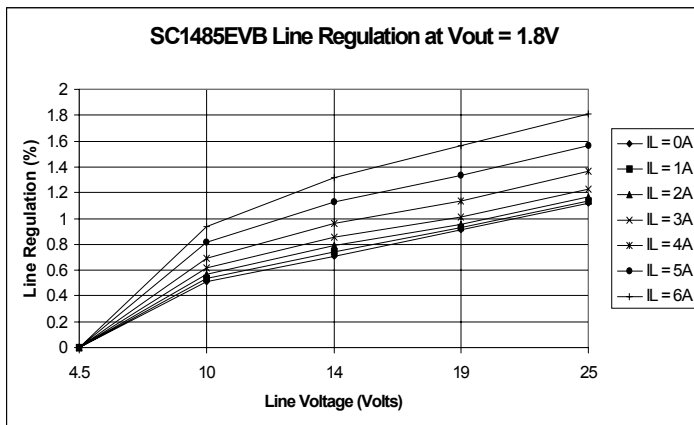
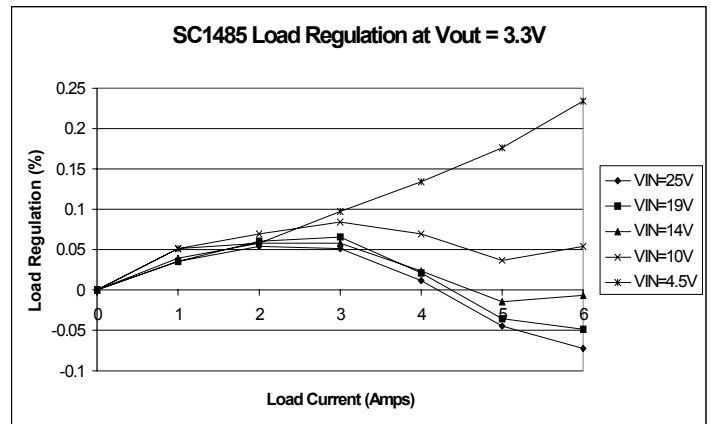
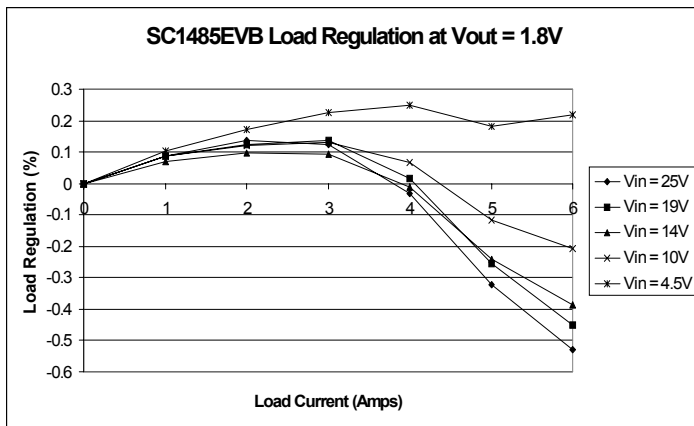
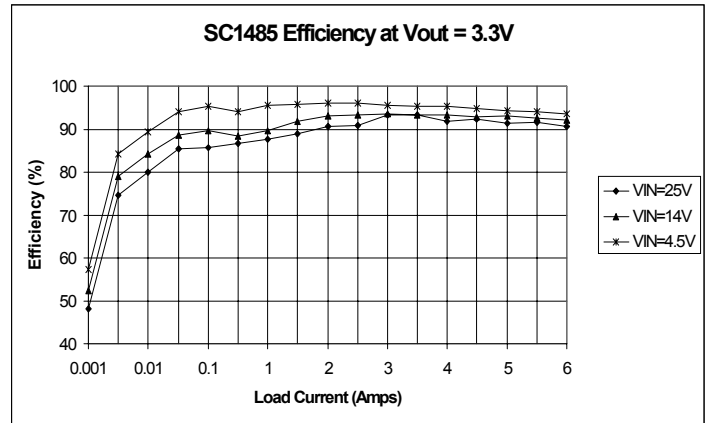
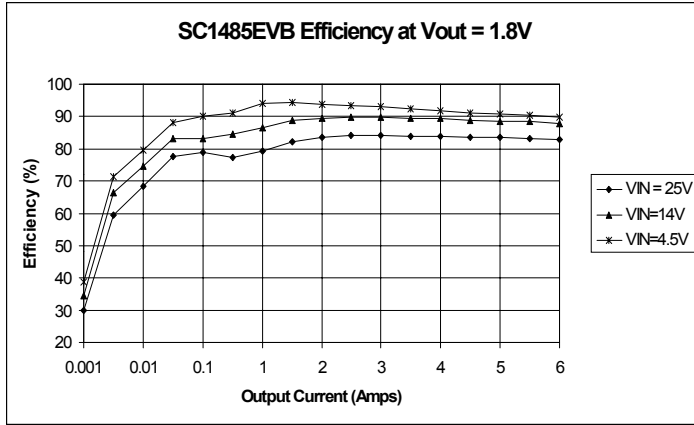
**POWER MANAGEMENT**
**Typical Characteristics**



**POWER MANAGEMENT**

**Typical Characteristics (Cont.)**

Load Release 6A - 0A, Forced Continuous Mode  
 $L = 2\mu\text{H}$ ,  $C_{out} = 600\mu\text{F}$ ,  $V_{out} = 1.8\text{V}$ ,  $V_{in} = 12\text{V}$ ,

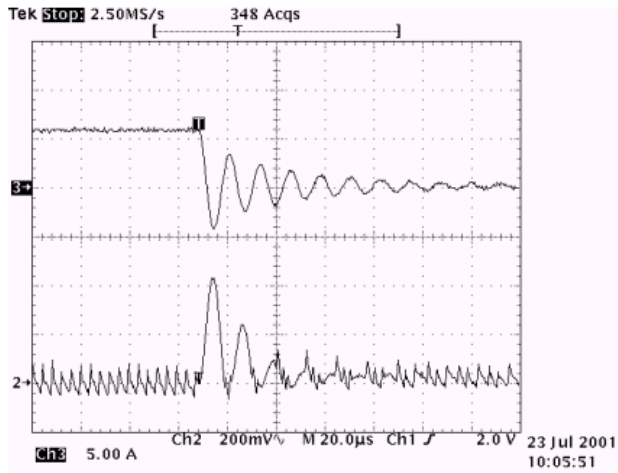

Load Applied 0A - 6A, Forced Continuous Mode  
 $L = 2\mu\text{H}$ ,  $C_{out} = 600\mu\text{F}$ ,  $V_{out} = 1.8\text{V}$ ,  $V_{in} = 12\text{V}$ ,

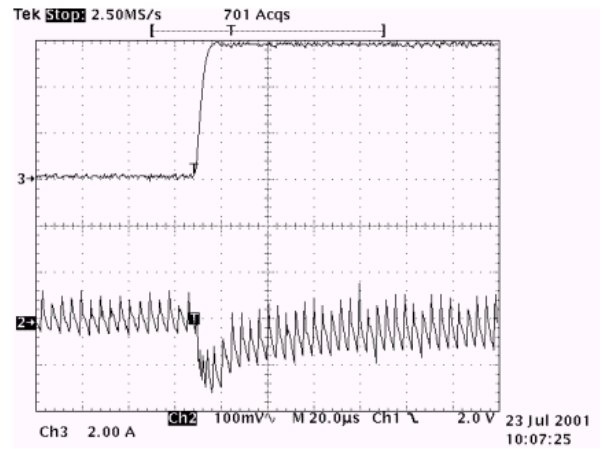

0A - 6A Transient, Forced Continuous Mode  
 $L = 2\mu\text{H}$ ,  $C_{out} = 600\mu\text{F}$ ,  $V_{out} = 1.8\text{V}$ ,  $V_{in} = 12\text{V}$

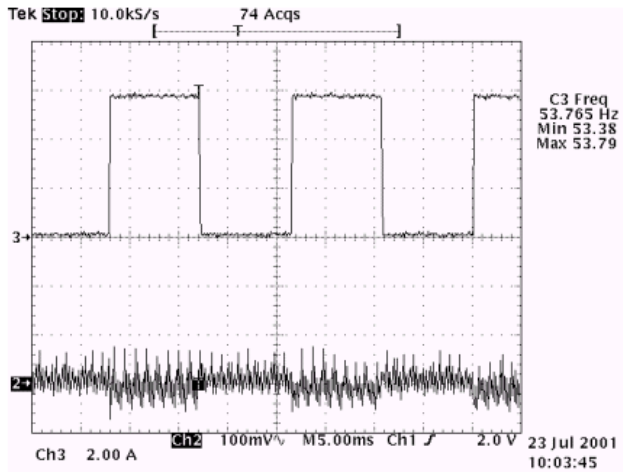

Forced Continuous Mode to PSAVE Mode

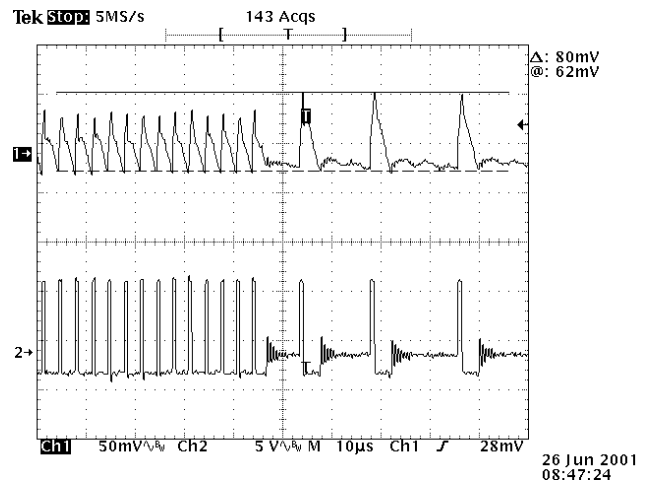

Upper Trace: Inductor Current  
 Lower Trace: Phase Lead

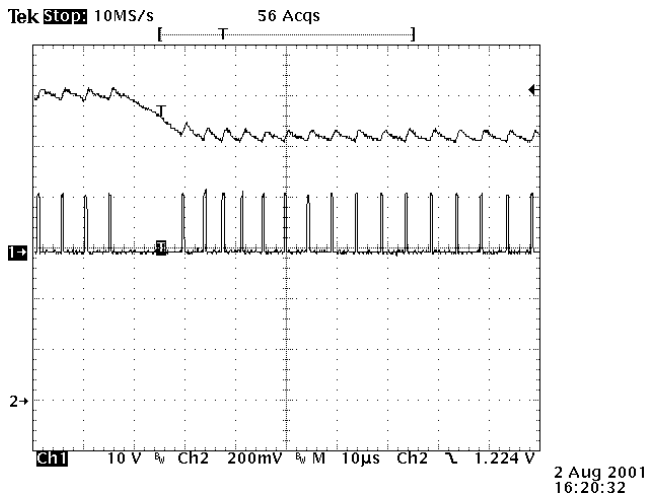

Upper Trace: Inductor Current  
 Lower Trace: Phase Lead

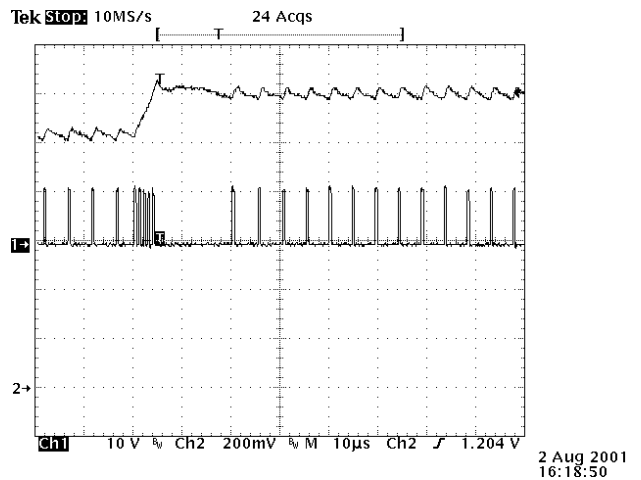

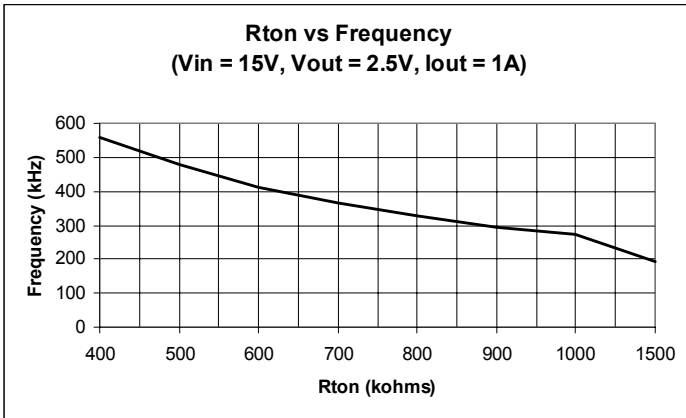
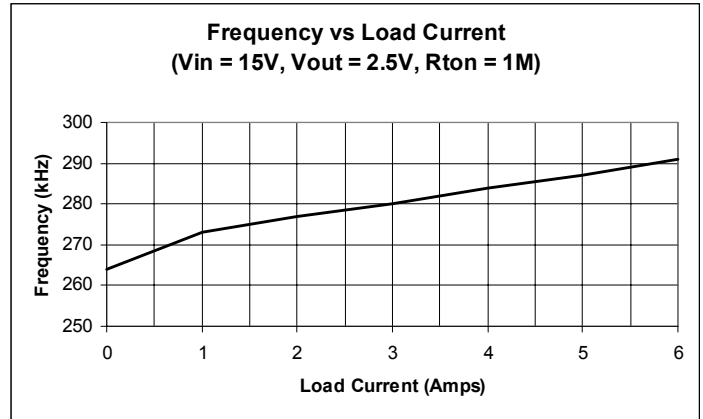
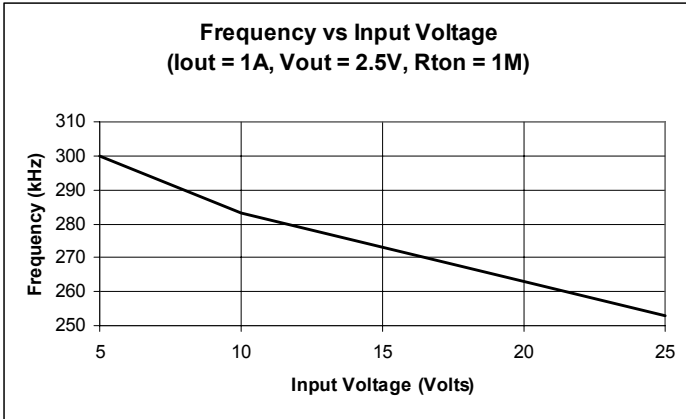
**POWER MANAGEMENT**
**Typical Characteristics (Cont.)**

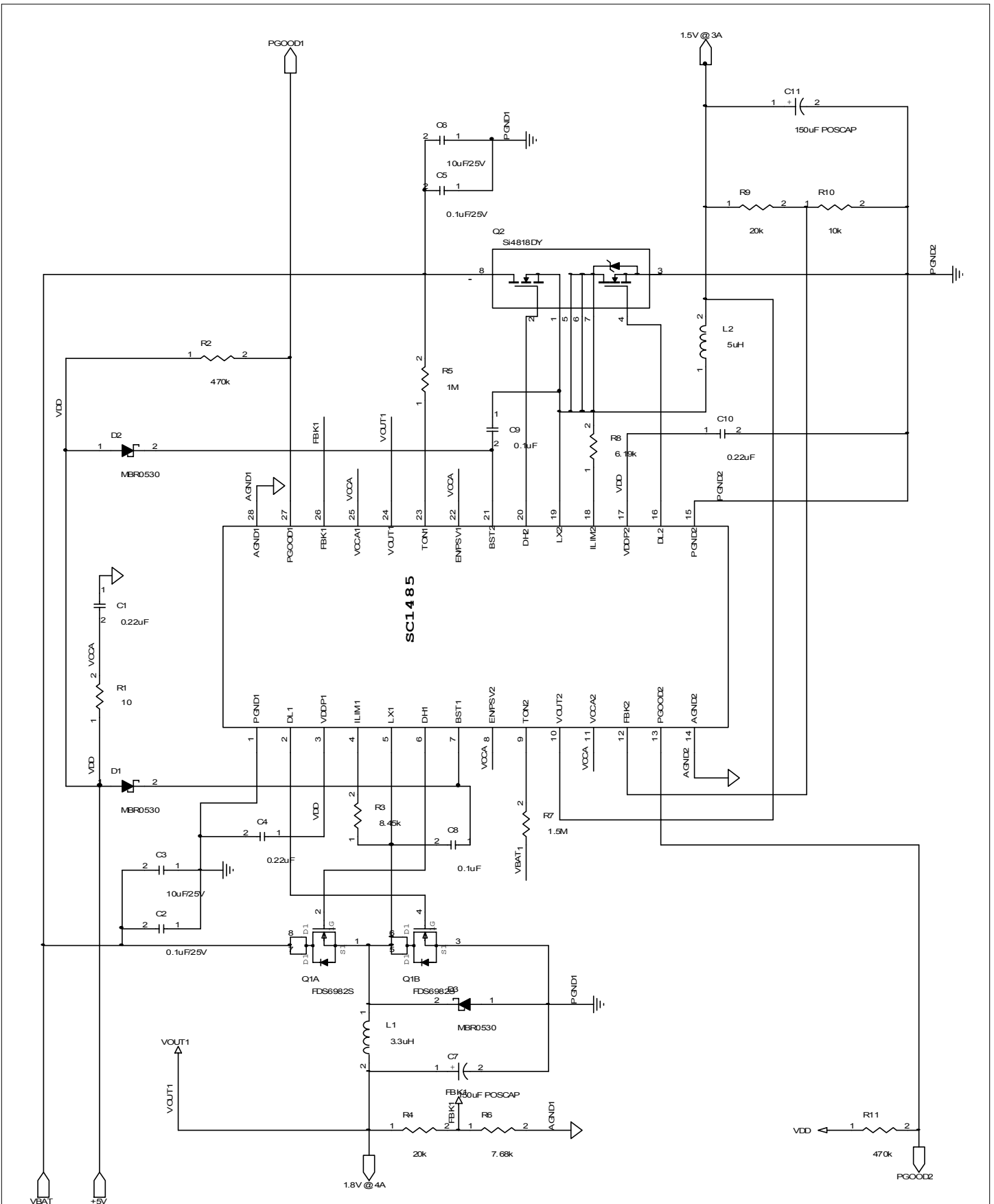



POWER MANAGEMENT

Outline Drawing - TSSOP-28

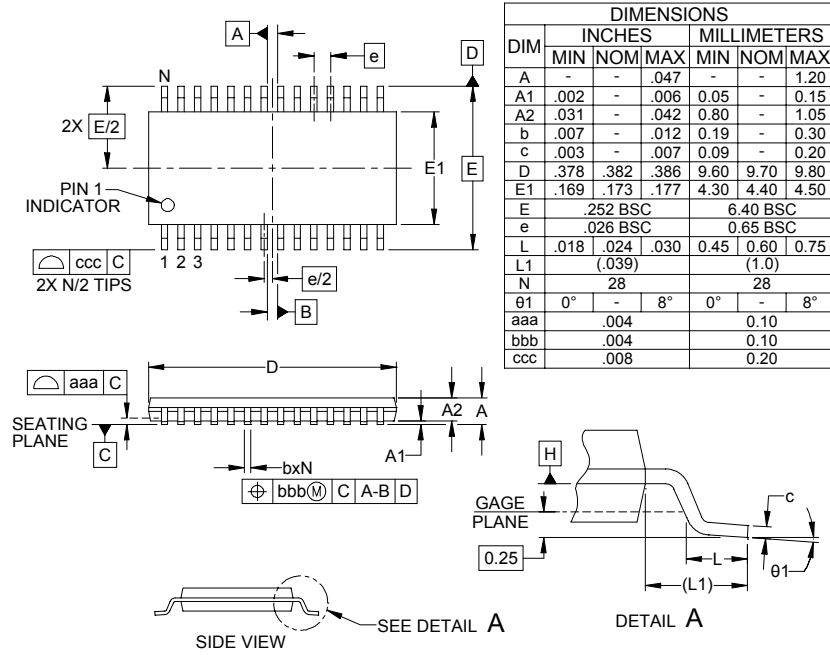

- NOTES:
1. CONTROLLING DIMENSIONS ARE IN MILLIMETERS (ANGLES IN DEGREES).
  2. DATUMS **-A-** AND **-B-** TO BE DETERMINED AT DATUM PLANE **-H-**
  3. DIMENSIONS "E1" AND "D" DO NOT INCLUDE MOLD FLASH, PROTRUSIONS OR GATE BURRS.
  4. REFERENCE JEDEC STD MO-153, VARIATION AE.

Land Pattern - TSSOP-28

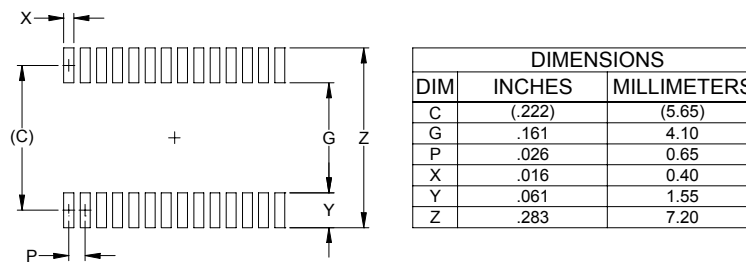

- NOTES:
1. THIS LAND PATTERN IS FOR REFERENCE PURPOSES ONLY. CONSULT YOUR MANUFACTURING GROUP TO ENSURE YOUR COMPANY'S MANUFACTURING GUIDELINES ARE MET.

Contact Information

Semtech Corporation  
 Power Management Products Division  
 200 Flynn Road, Camarillo, CA 93012  
 Phone: (805)498-2111 FAX (805)498-3804