

Digitally Controlled Potentiometer (XDCP™)

The Intersil X93154 is a digitally controlled potentiometer (XDCP). The device consists of a resistor array, wiper switches, a control section, and nonvolatile memory. The wiper position is controlled by a 3-wire interface.

The potentiometer is implemented by a resistor array composed of 31 resistive elements and a wiper switching network. The position of the wiper element is controlled by the \overline{CS} , U/\overline{D} , and \overline{INC} inputs. The position of the wiper can be stored in nonvolatile memory and then be recalled upon a subsequent power-up operation.

The device is connected as a two-terminal variable resistor and can be used in a wide variety of applications including:

- Bias and Gain Control
- LCD Contrast Adjustment

Features

- Solid-State Potentiometer
- 3-Wire Serial Interface
- 32 Wiper Tap Points
 - Wiper position stored in nonvolatile memory and recalled on power-up
- 31 Resistive Elements
 - Temperature compensated
 - Maximum resistance tolerance of $\pm 30\%$
 - Terminal voltage, 0 to V_{CC}
- Low Power CMOS
 - $V_{CC} = 3V \pm 10\%$
 - Active current, 250 μ A max.
 - Standby current, 1 μ A max.
- High Reliability
 - Endurance 200,000 data changes per bit
 - Register data retention, 100 years
- R_{TOTAL} Value = 50k Ω
- Packages
 - 8 Ld MSOP, TDFN
- Pb-Free Plus Anneal Available (RoHS Compliant)

Pinouts

X93154 (8 LD MSOP) TOP VIEW

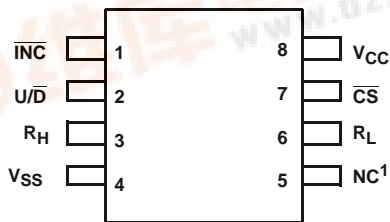

X93154 (8 LD TDFN) TOP VIEW

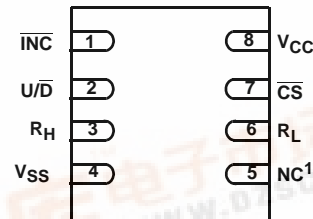

¹NC can be left unconnected, or connected to any voltage between V_{SS} and V_{CC}



X93154

Ordering Information

PART NUMBER	PART MARKING	V _{CC} LIMITS (V)	R _{TOTAL} (kΩ)	TEMP RANGE (°C)	PACKAGE
X93154UM8I-3*	AGK	3 ±10%	50	-40 to 85	8 Ld MSOP
X93154UM8IZ-3* (Note)	AIW			-40 to 85	8 Ld MSOP (Pb-free)
X93154UU8IZ-3* (Note)	AKH			-40 to 85	8 Ld TDFN (Pb-free)

*Add "T1" suffix for tape and reel.

NOTE: Intersil Pb-free plus anneal products employ special Pb-free material sets; molding compounds/die attach materials and 100% matte tin plate termination finish, which are RoHS compliant and compatible with both SnPb and Pb-free soldering operations. Intersil Pb-free products are MSL classified at Pb-free peak reflow temperatures that meet or exceed the Pb-free requirements of IPC/JEDEC J STD-020.

Block Diagram

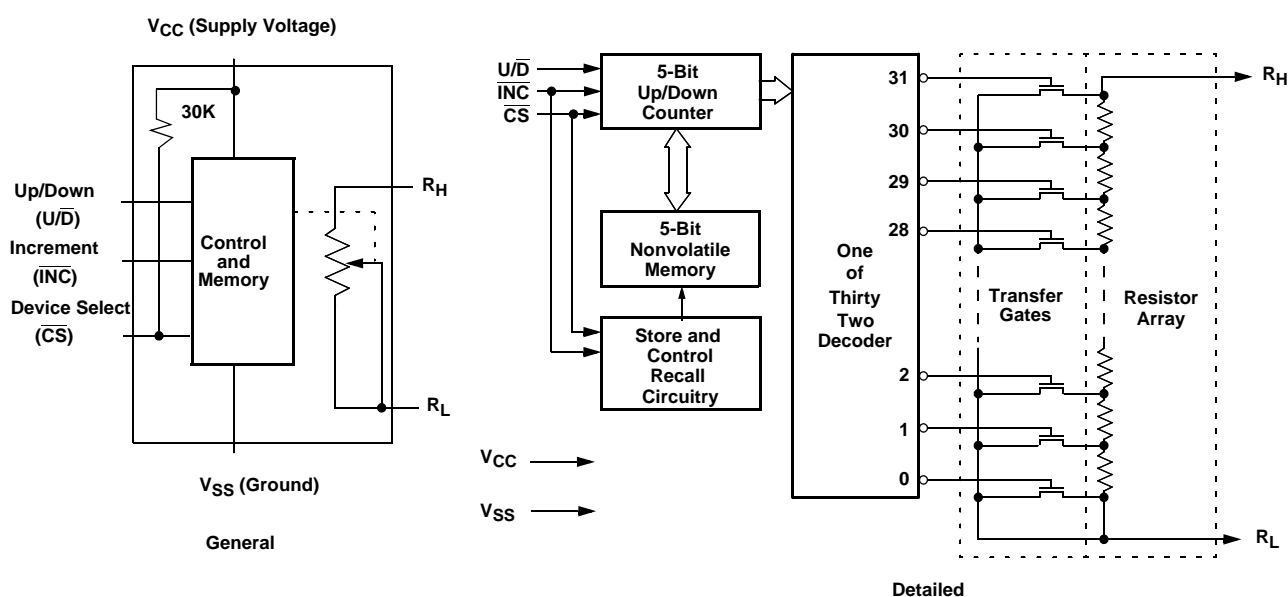

Pin Descriptions

MSOP, TDFN	SYMBOL	BRIEF DESCRIPTION
1	$\overline{\text{INC}}$	Increment (INC). The $\overline{\text{INC}}$ input is negative-edge triggered. Toggling $\overline{\text{INC}}$ will move the wiper and either increment or decrement the counter in the direction indicated by the logic level on the U/D input.
2	U/D	Up/Down (U/D). The U/D input controls the direction of the wiper movement and whether the counter is incremented or decremented.
3	R _H	R_H. The R _H and R _L pins of the X93154 are equivalent to the fixed terminals of a mechanical potentiometer. The minimum voltage is V _{SS} and the maximum is V _{CC} . The terminology of R _H and R _L references the relative position of the terminal in relation to wiper movement direction selected by the U/D input.
4	V _{SS}	Ground.
5	NC	No Connection. (or can be connected to any voltage between V _{SS} and V _{CC} .)
6	R _L	R_L. The R _H and R _L pins of the X93154 are equivalent to the fixed terminals of a mechanical potentiometer. The minimum voltage is V _{SS} and the maximum is V _{CC} . The terminology of R _H and R _L references the relative position of the terminal in relation to wiper movement direction selected by the U/D input.
7	$\overline{\text{CS}}$	Chip Select ($\overline{\text{CS}}$). The device is selected when the $\overline{\text{CS}}$ input is LOW. The current counter value is stored in nonvolatile memory when $\overline{\text{CS}}$ is returned HIGH while the $\overline{\text{INC}}$ input is also HIGH. After the store operation is complete, the X93154 will be placed in the low power standby mode until the device is selected once again.
8	V _{CC}	Supply Voltage.

X93154

Absolute Maximum Ratings

Temperature under bias	-65°C to +135°C
Storage temperature	-65°C to +150°C
Voltage on \overline{CS} , \overline{INC} , U/\overline{D} , R_H , R_L and V_{CC} with respect to V_{SS}	-1V to +6.5V
Lead temperature (soldering 10s)	300°C
Maximum resistor current	2mA

Recommended Operating Conditions

Temperature Range	Industrial	-40°C to +85°C
Supply Voltage	V_{CC}	3V \pm 10% ⁽⁸⁾

CAUTION: Stresses above those listed in "Absolute Maximum Ratings" may cause permanent damage to the device. This is a stress only rating and operation of the device at these or any other conditions above those indicated in the operational sections of this specification is not implied.

Potentiometer Specifications Over recommended operating conditions unless otherwise stated.

SYMBOL	PARAMETER	TEST CONDITIONS/NOTES	MIN	TYP	MAX	UNIT
R_{TOT}	End to end resistance		35	50	65	k Ω
V_R	R_H , R_L terminal voltages		0		V_{CC}	V
	Power rating	$R_{TOTAL} = 50k\Omega$			1	mW ⁽⁷⁾
	Noise	Ref: 1kHz		-120		dBV ⁽⁷⁾
R_W	Wiper Resistance	(5) (6)			1000	Ω
I_W	Wiper Current	(5) (6)			0.6	mA
	Resolution			3		%
	Absolute linearity ⁽¹⁾	$V_{H(n)(actual)} - V_{H(n)(expected)}$			± 1	MI ⁽³⁾
	Relative linearity ⁽²⁾	$V_{H(n+1)} - [V_{H(n)} + MI]$			± 0.5	MI ⁽³⁾
	R_{TOTAL} temperature coefficient	(7)			± 35	ppm/ $^{\circ}C$
$C_H/C_L/C_W$	Potentiometer capacitances	See circuit #3		10/10/25		pF ⁽⁷⁾

NOTES:

- Absolute linearity is utilized to determine actual wiper voltage versus expected voltage = $(V_{H(n)(actual)} - V_{H(n)(expected)}) = \pm 1$ MI Maximum. n = 1 .. 29 only
- Relative linearity is a measure of the error in step size between taps = $V_{H(n+1)} - [V_{H(n)} + MI] = \pm 0.5$ MI, n = 1 .. 29 only.
- 1 MI = Minimum Increment = $R_{TOT}/31$.
- Typical values are for $T_A = 25^{\circ}C$ and nominal supply voltage.
- This parameter is periodically sampled and not 100% tested
- Typical values are for $T_A = 25^{\circ}C$ and nominal supply voltage.
- This parameter is not 100% tested.
- When performing multiple write operations, V_{CC} must not decrease by more than 150mV from its initial value.

DC Electrical Specifications Over recommended operating conditions unless otherwise specified.

SYMBOL	PARAMETER	TEST CONDITIONS	MIN	TYP ⁽⁴⁾	MAX	UNIT
I_{CC1}	V_{CC} active current (Increment)	$\overline{CS} = V_{IL}$, $U/\overline{D} = V_{IL}$ or V_{IH} and $\overline{INC} = 0.4V$ @ max. t_{CYC}		50	250	μA
I_{CC2}	V_{CC} active current (Store) (EEPROM Store)	$\overline{CS} = V_{IH}$, $U/\overline{D} = V_{IL}$ or V_{IH} and $\overline{INC} = V_{IH}$ @ max. t_{WR}			600	μA
I_{SB}	Standby supply current	$\overline{CS} = V_{CC} - 0.3V$, U/\overline{D} and $\overline{INC} = V_{SS}$ or $V_{CC} - 0.3V$			1	μA
I_{LI}	CS	$V_{IN} = V_{CC}$			± 1	μA
I_{LI}	CS	$V_{CC} = 3V$, $\overline{CS} = 0$	60	100	150	μA
I_{LI}	\overline{INC} , U/\overline{D} input leakage current	$V_{IN} = V_{SS}$ to V_{CC}			± 1	μA
V_{IH}	\overline{CS} , \overline{INC} , U/\overline{D} input HIGH voltage		$V_{CC} \times 0.7$		$V_{CC} + 0.5$	V
V_{IL}	\overline{CS} , \overline{INC} , U/\overline{D} input LOW voltage		-0.5		$V_{CC} \times 0.1$	V
$C_{IN}^{(5)(7)}$	\overline{CS} , \overline{INC} , U/\overline{D} input capacitance	$V_{CC} = 3V$, $V_{IN} = V_{SS}$, $T_A = 25^{\circ}C$, $f = 1MHz$			10	pF

X93154

Endurance and Data Retention

PARAMETER	MIN	UNIT
Minimum endurance	200,000	Data changes per bit
Data retention	100	Years

Test Circuit #1

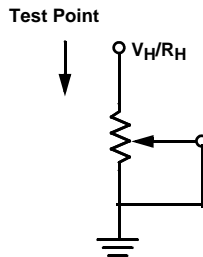

Circuit #2 SPICE Macro Model

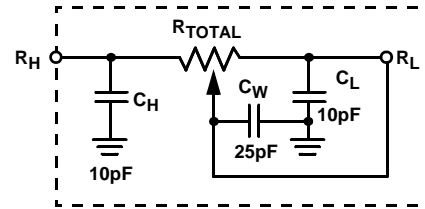

A.C. Conditions of Test

Input pulse levels	0V to 3V
Input rise and fall times	10ns
Input reference levels	1.5V

AC Electrical Specifications

Over recommended operating conditions unless otherwise specified.

SYMBOL	PARAMETER	MIN	TYP(6)	MAX	UNIT
t_{CI}	\overline{CS} to \overline{INC} setup	100			ns
t_{ID}	\overline{INC} HIGH to U/\overline{D} change	100			ns
t_{DI}	U/\overline{D} to \overline{INC} setup	100			ns
t_{iL}	\overline{INC} LOW period	1			μ s
t_{iH}	\overline{INC} HIGH period	1			μ s
t_{iC}	\overline{INC} Inactive to \overline{CS} inactive	1			μ s
t_{CPH}	\overline{CS} Deselect time (NO STORE)	250			ns
t_{CPH}	\overline{CS} Deselect time (STORE)	10			ms
t_{CYC}	\overline{INC} cycle time	2			μ s
$t_R, t_F^{(7)}$	\overline{INC} input rise and fall time			500	μ s
$t_{R V_{CC}}^{(7)}$	V_{CC} power-up rate	1.0		10,000	V/ms
t_{WR}	Store cycle		5	10	ms

Power Up and Down Requirements

There are no restrictions on the power-up or power-down conditions of V_{CC} and the voltages applied to the

potentiometer pins provided that V_{CC} is always more positive than or equal to V_H and V_L , i.e., $V_{CC} \geq V_H, V_L$. The V_{CC} ramp rate spec is always in effect.

A.C. Timing

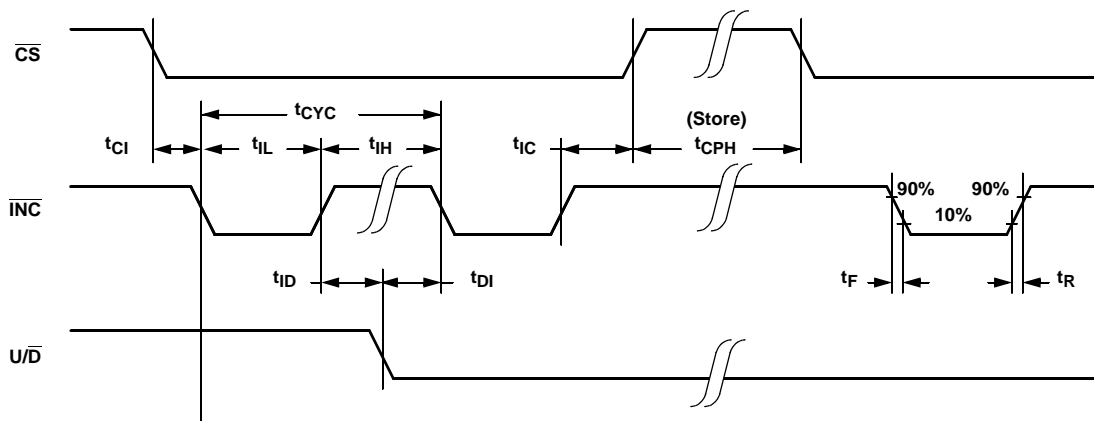

Pin Descriptions

R_H and R_L

The R_H and R_L pins of the X93154 are equivalent to the fixed terminals of a mechanical potentiometer. The minimum voltage is V_{SS} and the maximum is V_{CC} . The terminology of R_H and R_L references the relative position of the terminal in relation to wiper movement direction selected by the U/\bar{D} input.

Up/Down (U/\bar{D})

The U/\bar{D} input controls the direction of the wiper movement and whether the counter is incremented or decremented.

Increment (\bar{INC})

The \bar{INC} input is negative-edge triggered. Toggling \bar{INC} will move the wiper and either increment or decrement the counter in the direction indicated by the logic level on the U/\bar{D} input.

Chip Select (\bar{CS})

The device is selected when the \bar{CS} input is LOW. The current counter value is stored in nonvolatile memory when \bar{CS} is returned HIGH while the \bar{INC} input is also HIGH. After the store operation is complete the X93154 will be placed in the low power standby mode until the device is selected once again.

Pin Configuration

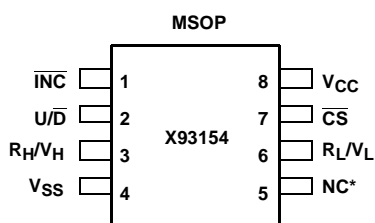

*NC = No Connect. Can be connected to any voltage between V_{SS} and V_{CC} , or left unconnected.

Pin Names

SYMBOL	DESCRIPTION
R_H	High terminal
R_L	Low terminal
V_{SS}	Ground
V_{CC}	Supply voltage
U/\bar{D}	Up/Down control input
\bar{INC}	Increment control input
\bar{CS}	Chip Select control input

Principles of Operation

There are three sections of the X93154: the input control, counter and decode section; the nonvolatile memory; and the resistor array. The input control section operates just like an up/down counter. The output of this counter is decoded to turn on a single electronic switch connecting a point on the resistor array to the wiper output. Under the proper conditions the contents of the counter can be stored in nonvolatile memory and retained for future use. The resistor array is comprised of 31 individual resistors connected in series. At either end of the array and between each resistor is an electronic switch that transfers the connection at that point to the wiper.

The wiper, when at either fixed terminal, acts like its mechanical equivalent and does not move beyond the last position. That is, the counter does not wrap around when clocked to either extreme.

If the wiper is moved several positions, multiple taps are connected to the wiper for t_{1W} (INC to V_W change). The 2-terminal resistance value for the device can temporarily change by a significant amount if the wiper is moved several positions.

When the device is powered-down, the last wiper position stored will be maintained in the nonvolatile memory. When power is restored, the contents of the memory are recalled and the wiper is set to the value last stored.

Instructions and Programming

The \bar{INC} , U/\bar{D} and \bar{CS} inputs control the movement of the wiper along the resistor array. With \bar{CS} set LOW the device is selected and enabled to respond to the U/\bar{D} and \bar{INC} inputs. HIGH to LOW transitions on \bar{INC} will increment or decrement (depending on the state of the U/\bar{D} input) a five bit counter. The output of this counter is decoded to select one of thirty two wiper positions along the resistive array.

The value of the counter is stored in nonvolatile memory whenever \bar{CS} transitions HIGH while the \bar{INC} input is also HIGH. In order to avoid an accidental store during power-up, \bar{CS} must go HIGH with V_{CC} during initial power-up. When performing multiple write operations, V_{CC} must not decrease by more than 150mV from its initial value. When left open, the \bar{CS} pin is internally pulled up to V_{CC} by an internal 30k resistor.

The system may select the X93154, move the wiper and deselect the device without having to store the latest wiper position in nonvolatile memory. After the wiper movement is performed as described above and once the new position is reached, the system must keep \bar{INC} LOW while taking \bar{CS} HIGH. The new wiper position will be maintained until changed by the system or until a power-up/down cycle recalled the previously stored data. In order to recall the stored position of the wiper on power-up, the \bar{CS} pin must be held HIGH.

X93154

This procedure allows the system to always power-up to a preset value stored in nonvolatile memory; then during system operation minor adjustments could be made. The adjustments might be based on user preference, system parameter changes due to temperature drift, or other system trim requirements.

The state of $\overline{U/D}$ may be changed while \overline{CS} remains LOW. This allows the host system to enable the device and then move the wiper up and down until the proper trim is attained.

Mode Selection

\overline{CS}	\overline{INC}	$\overline{U/D}$	MODE
L		H	Wiper Up
L		L	Wiper Down
	H	X	Store Wiper Position
H	X	X	Standby Current
	L	X	No Store, Return to Standby
	L	H	Wiper Up (not recommended)
	L	L	Wiper Down (not recommended)

Symbol Table

WAVEFORM	INPUTS	OUTPUTS
	Must be steady	Will be steady
	May change from Low to High	Will change from Low to High
	May change from High to Low	Will change from High to Low
	Don't Care: Changes Allowed	Changing: State Not Known
	N/A	Center Line is High Impedance

Applications Information

Electronic digitally controlled (XDCP) potentiometers provide three powerful application advantages; (1) the variability and reliability of a solid-state potentiometer (2) the flexibility of computer-based digital controls, and (3) the retentivity of nonvolatile memory used for the storage of multiple potentiometer settings or data.

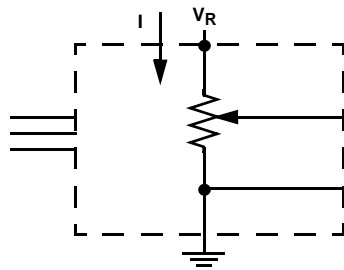

Two terminal variable resistor.
variable current

Low Voltage High Impedance Instrumentation Amplifier

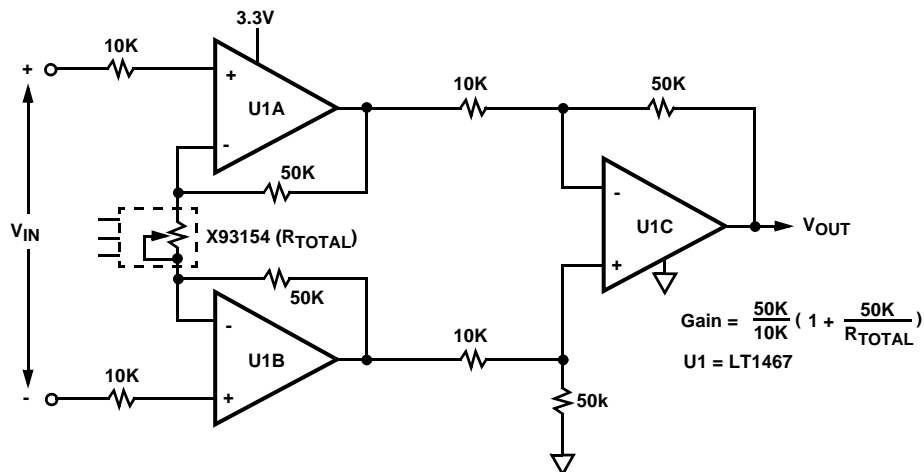

Applications Information (Continued)

Micro-Power LCD Contrast Control

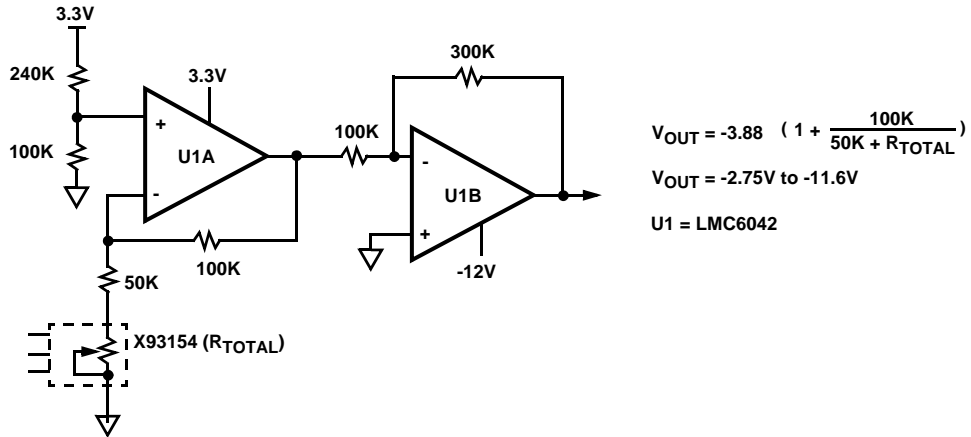

Single Supply Variable Gain Amplifier

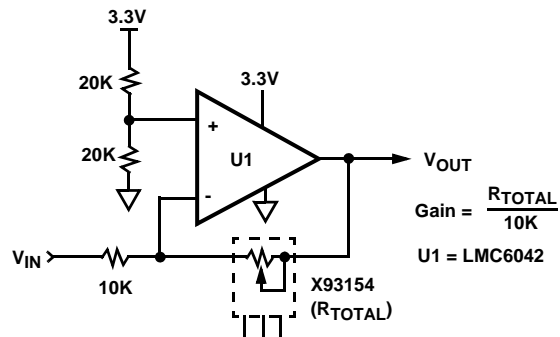

X93154

MSOP Packaging Information

8-Lead Miniature Small Outline Gull Wing Package Type M

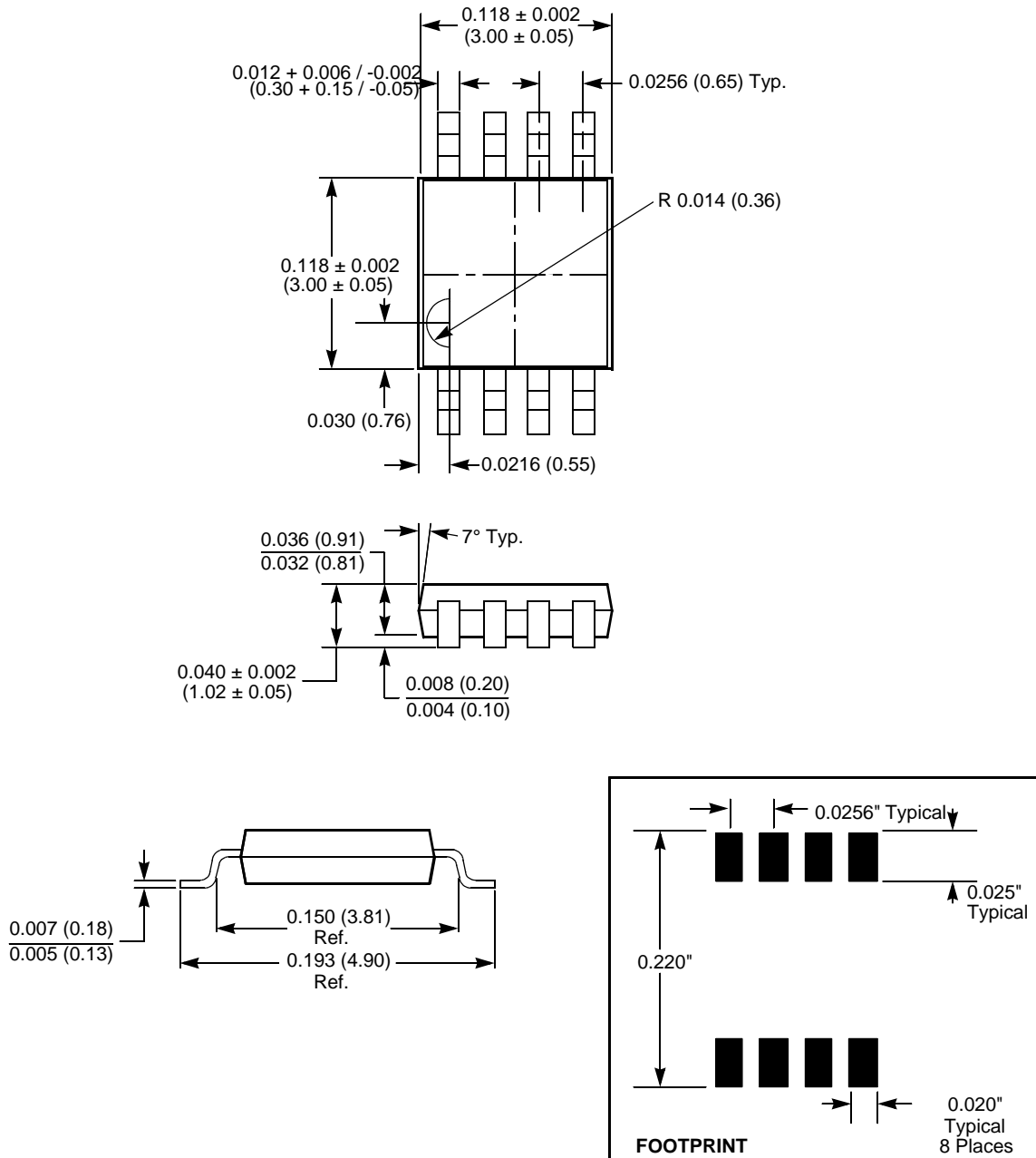

NOTE:

1. ALL DIMENSIONS IN INCHES AND (MILLIMETERS)

