

- Improved Stability Over Supply Voltage and Temperature Ranges
- Constant-Current Outputs
- High Speed
- Standard Supply Voltages
- High Output Impedance
- High Common-Mode Output Voltage Range . . . -3 V to 10 V
- TTL-Input Compatibility
- Inhibitor Available for Driver Selection
- Glitch-Free During Power Up/Power Down
- SN75112 and External Circuit Meets or Exceeds the Requirements of CCITT Recommendation V.35
- Package Options Include Plastic Small-Outline (D), Package, and Ceramic Chip Carriers (FK), Standard Plastic (N) and Ceramic (J) DIPs

**description**

The SN55110A, SN75110A, and SN75112 dual line drivers have improved output current regulation with supply voltage and temperature variations. In addition, the higher current of the SN75112 (27 mA) allows data to be transmitted over longer lines. These drivers offer optimum performance when used with the SN55107A, SN75107A, and SN75108A line receivers.

These drivers feature independent channels with common voltage supply and ground terminals. The significant difference between the three drivers is in the output-current specification. The driver circuits feature a constant output current that is switched to either of two output terminals by the appropriate logic levels at the input terminals. The output current can be switched off (inhibited) by low logic levels on the enable inputs. The output current is nominally 12 mA for the '110A devices, and is 27 mA for the SN75112.

The enable/inhibit feature is provided so the circuits can be used in party-line or data-bus applications. A strobe or inhibitor (enable D), common to both drivers, is included for increased driver-logic versatility. The output current in the inhibited mode,  $I_{O(off)}$ , is specified so that minimum line loading is induced when the driver is used in a party-line system with other drivers. The output impedance of the driver in the inhibited mode is very high. The output impedance of a transistor is biased to cutoff.

The driver outputs have a common-mode voltage range of -3 V to 10 V, allowing common-mode voltage on the line without affecting driver performance.

All inputs are diode clamped and are designed to satisfy TTL-system requirements. The inputs are tested at 2 V for high-logic-level input conditions and 0.8 V for low-logic-level input conditions. These tests ensure 400-mV noise margin when interfaced with TTL Series 54/74.

SN55110A . . . J OR W PACKAGE  
 SN75110A, SN75112 . . . D OR N PACKAGE  
 (TOP VIEW)

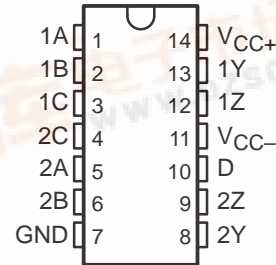

SN55110A . . . FK PACKAGE  
 (TOP VIEW)

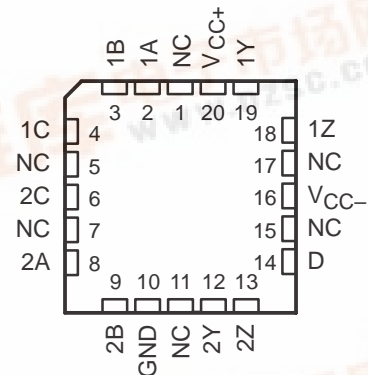

NC – No internal connection

Please be aware that an important notice concerning availability, standard warranty, and use in critical applications of Texas Instruments semiconductor products and disclaimers thereto appears at the end of this data sheet.

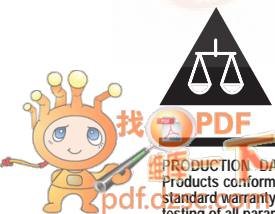

# SN55110A, SN75110A, SN75112 DUAL LINE DRIVERS

SLLS106E – DECEMBER 1975 – REVISED APRIL 2000

The SN55110A is characterized for operation over the full military temperature range of  $-55^{\circ}\text{C}$  to  $125^{\circ}\text{C}$ . The SN75110A and SN75112 are characterized for operation from  $0^{\circ}\text{C}$  to  $70^{\circ}\text{C}$ .

## AVAILABLE OPTIONS

T <sub>A</sub>	PACKAGED DEVICES				
	PLASTIC SMALL OUTLINE (D)	PLASTIC CHIP CARRIER (FK)	CERAMIC DIP (J)	PLASTIC DIP (N)	CERAMIC FLATPACK (W)
0°C to 70°C	SN75110AD SN75112D			SN75110AN SN75112N	
-55°C to 125°C		SN5510AFK	SN55110AJ		SN55110AW

The D package is available taped and reeled. Add the suffix R to the device type (e.g., SN75110ADR).

## FUNCTION TABLE (each driver)

LOGIC INPUTS		ENABLE INPUTS		OUTPUTS†	
A	B	C	D	Y	Z
X	X	L	X	Off	Off
X	X	X	L	Off	Off
L	X	H	H	On	Off
X	L	H	H	On	Off
H	H	H	H	Off	On

H = high level, L = low level, X = irrelevant

† When using only one channel of the line drivers, the other channel should be inhibited and/or have its outputs grounded.

# SN55110A, SN75110A, SN75112 DUAL LINE DRIVERS

SLLS106E – DECEMBER 1975 – REVISED APRIL 2000

## schematic (each driver)

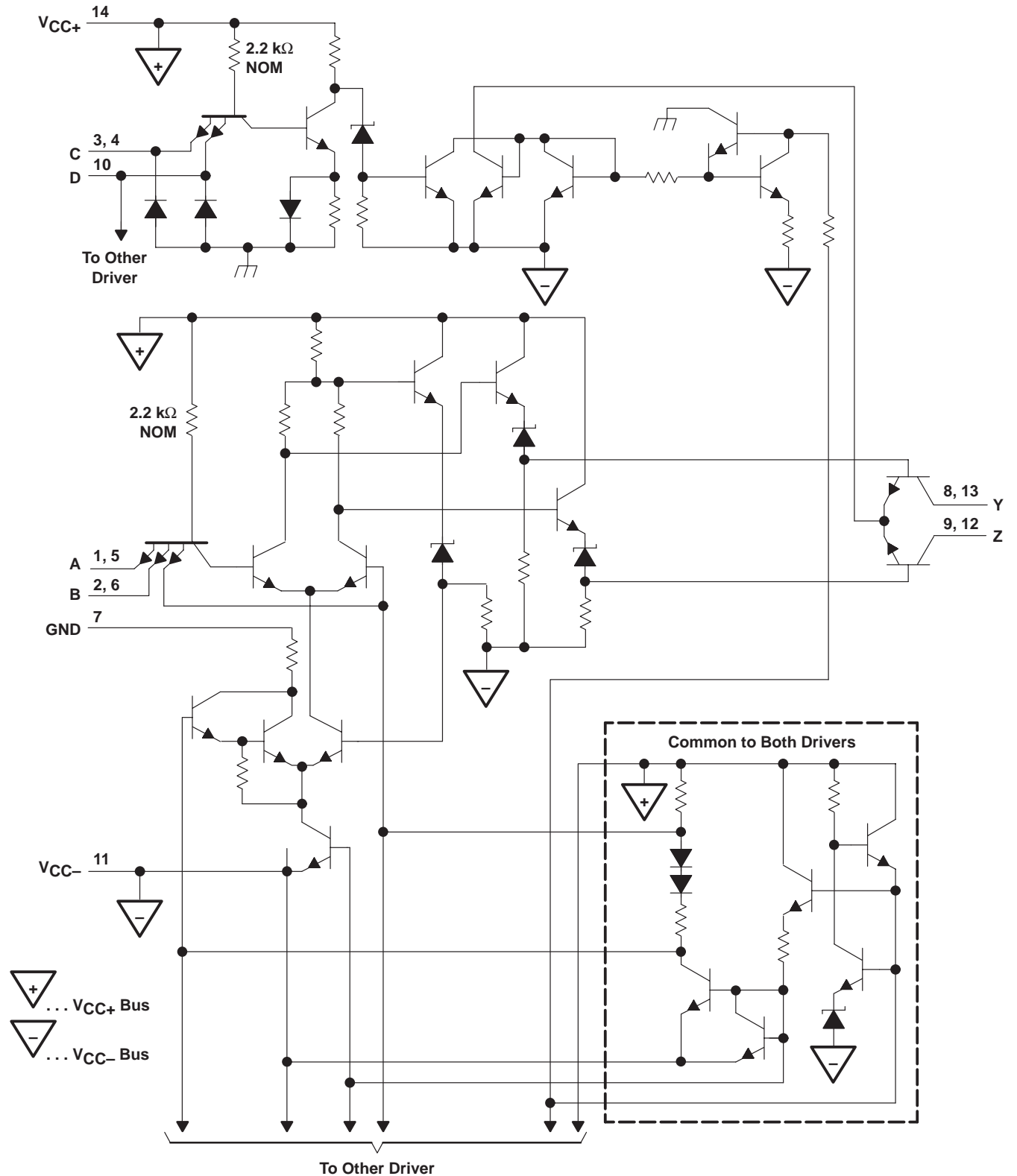

Pin numbers shown are for the D, J, N, and W packages.

# SN55110A, SN75110A, SN75112 DUAL LINE DRIVERS

SLLS106E – DECEMBER 1975 – REVISED APRIL 2000

## absolute maximum ratings over operating free-air temperature (unless otherwise noted)†

Supply voltage, $V_{CC+}$ (see Note 1)	7 V
Supply voltage, $V_{CC-}$	-7 V
Input voltage, $V_I$	5.5 V
Output voltage range, $V_O$	-5 V to 12 V
Package thermal impedance, $\theta_{JA}$ (see Note 2): D package	86°C/W
N package	80°C/W
Continuous total power dissipation (see Note 3)	See Dissipation Rating Table
Case temperature for 60 seconds: FK package	260°C
Lead temperature 1,6 mm (1/16 inch) from case for 60 seconds: J or W package	300°C
Lead temperature 1,6 mm (1/16 inch) from case for 10 seconds: D or N package	260°C
Storage temperature range, $T_{stg}$	-65°C to 150°C

† Stresses beyond those listed under “absolute maximum ratings” may cause permanent damage to the device. These are stress ratings only, and functional operation of the device at these or any other conditions beyond those indicated under “recommended operating conditions” is not implied. Exposure to absolute-maximum-rated conditions for extended periods may affect device reliability.

- NOTES:
1. Voltage values are with respect to network ground terminal.
  2. The package thermal impedance is calculated in accordance with JESD 51.
  3. In the FK, J, or W package, SN55110A chips are either silver glass or alloy mounted; SN75110A and SN75112 chips are glass mounted.

DISSIPATION RATING TABLE

PACKAGE	$T_A \leq 25^\circ\text{C}$	DERATING FACTOR ABOVE $T_A = 25^\circ\text{C}$	$T_A = 70^\circ\text{C}$	$T_A = 125^\circ\text{C}$
	POWER RATING		POWER RATING	POWER RATING
FK	1375 mW	11 mW/°C	880 mW	275 mW
J	1375 mW	11 mW/°C	880 mW	275 mW
W	1000 mW	8 mW/°C	640 mW	200 mW

## recommended operating conditions (see Note 4)

	SN55110A			SN75110A SN75112			UNIT
	MIN	NOM	MAX	MIN	NOM	MAX	
Supply voltage, $V_{CC+}$	4.5	5	5.5	4.75	5	5.25	V
Supply voltage, $V_{CC-}$	-4.5	-5	-5.5	-4.75	-5	-5.25	V
Positive common-mode output voltage	0		10	0		10	V
Negative common-mode output voltage	0		-3	0		-3	V
High-level input voltage, $V_{IH}$	2			2			V
Low-level output current, $V_{IL}$			0.8			0.8	V
Operating free-air temperature, $T_A$	-55		125	0		70	°C

NOTE 4: When using only one channel of the line drivers, the other channel should be inhibited and/or have its outputs grounded.

# SN55110A, SN75110A, SN75112 DUAL LINE DRIVERS

SLLS106E – DECEMBER 1975 – REVISED APRIL 2000

**electrical characteristics over recommended operating free-air temperature range (unless otherwise noted)**

PARAMETER		TEST CONDITIONS†	SN55110A SN75110A			SN75112			UNIT
			MIN	TYP‡	MAX	MIN	TYP‡	MAX	
V <sub>IK</sub>	Input clamp voltage	V <sub>CC±</sub> = MIN, I <sub>L</sub> = -12 mA	-0.9	-1.5		-0.9	-1.5	V	
I <sub>O(on)</sub>	On-state output current	V <sub>CC±</sub> = MAX, V <sub>O</sub> = 10 V	12	15		27	36	mA	
		V <sub>CC</sub> = MIN to MAX, V <sub>O</sub> = -1 V to 1 V, T <sub>A</sub> = 25°C				24	28		32
		V <sub>CC±</sub> = MIN, V <sub>O</sub> = -3 V	6.5	12		18	27		
I <sub>O(off)</sub>	Off-state output current	V <sub>CC±</sub> = MIN, V <sub>O</sub> = 10 V			100		100	μA	
I <sub>I</sub>	Input current at maximum input voltage	A, B, or C inputs	V <sub>CC±</sub> = MAX, V <sub>I</sub> = 5.5 V			1			mA
		D input							
I <sub>IH</sub>	High-level input current	A, B, or C inputs	V <sub>CC±</sub> = MAX, V <sub>I</sub> = 2.4 V			40			μA
		D input							
I <sub>IL</sub>	Low-level input current	A, B, or C inputs	V <sub>CC±</sub> = MAX, V <sub>I</sub> = 0.4 V			-3			mA
		D input							
I <sub>CC+(on)</sub>	Supply current from V <sub>CC</sub> with driver enabled	V <sub>CC±</sub> = MAX, A and B inputs at 0.4 V, C and D inputs at 2 V	23	35		25	40	mA	
I <sub>CC-(on)</sub>	Supply current from V <sub>CC-</sub> with driver enabled	V <sub>CC±</sub> = MAX, A and B inputs at 0.4 V, C and D inputs at 2 V	-34	-50		-65	-100	mA	
I <sub>CC+(off)</sub>	Supply current from V <sub>CC-</sub> with driver inhibited	V <sub>CC±</sub> = MAX, A, B, C, and D inputs at 0.4 V	21			30		mA	
I <sub>CC-(off)</sub>	Supply current from V <sub>CC±</sub> with driver inhibited	V <sub>CC±</sub> = MAX, A, B, C, and D inputs at 0.4 V	-17			-32		mA	

† For conditions shown as MIN or MAX, use appropriate value specified under recommended operating conditions.

‡ All typical values are at V<sub>CC+</sub> = 5 V, V<sub>CC-</sub> = -5 V, T<sub>A</sub> = 25°C.

## switching characteristics, V<sub>CC±</sub> = ±5 V, T<sub>A</sub> = 25°C

PARAMETER§	FROM (INPUT)	TO (OUTPUT)	TEST CONDITIONS	MIN	TYP	MAX	UNIT
t <sub>PLH</sub>	A or B	Y or Z	C <sub>L</sub> = 40 pF, R <sub>L</sub> = 50 Ω, See Figure 1		9	15	ns
t <sub>PHL</sub>					9	15	
t <sub>PLH</sub>	C or D	Y or Z			16	25	ns
t <sub>PHL</sub>					13	25	

§ t<sub>PLH</sub> = Propagation delay time, low-to-high-level output

t<sub>PHL</sub> = Propagation delay time, high-to-low-level output

# SN55110A, SN75110A, SN75112 DUAL LINE DRIVERS

SLLS106E – DECEMBER 1975 – REVISED APRIL 2000

## PARAMETER MEASUREMENT INFORMATION

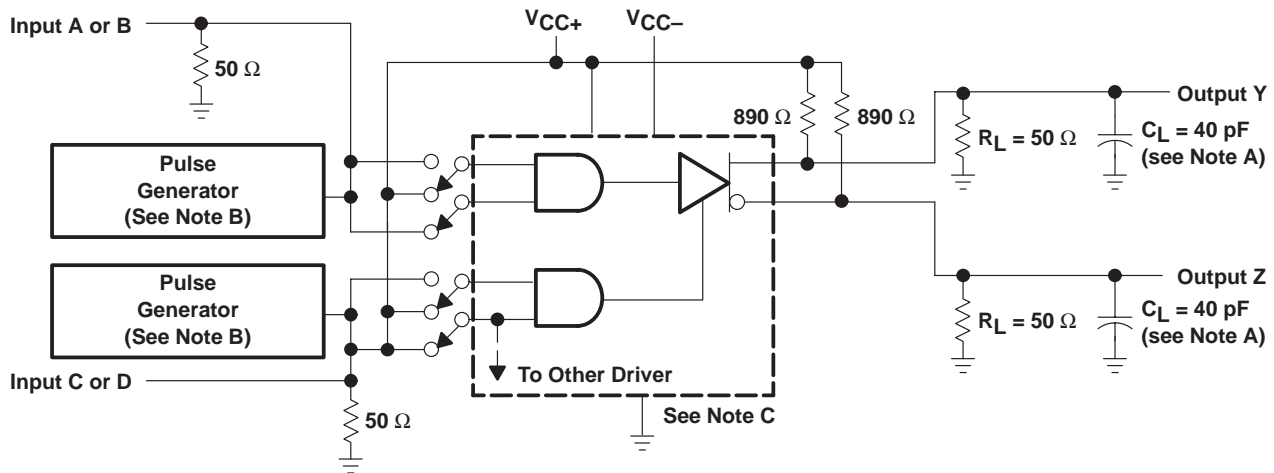

TEST CIRCUIT

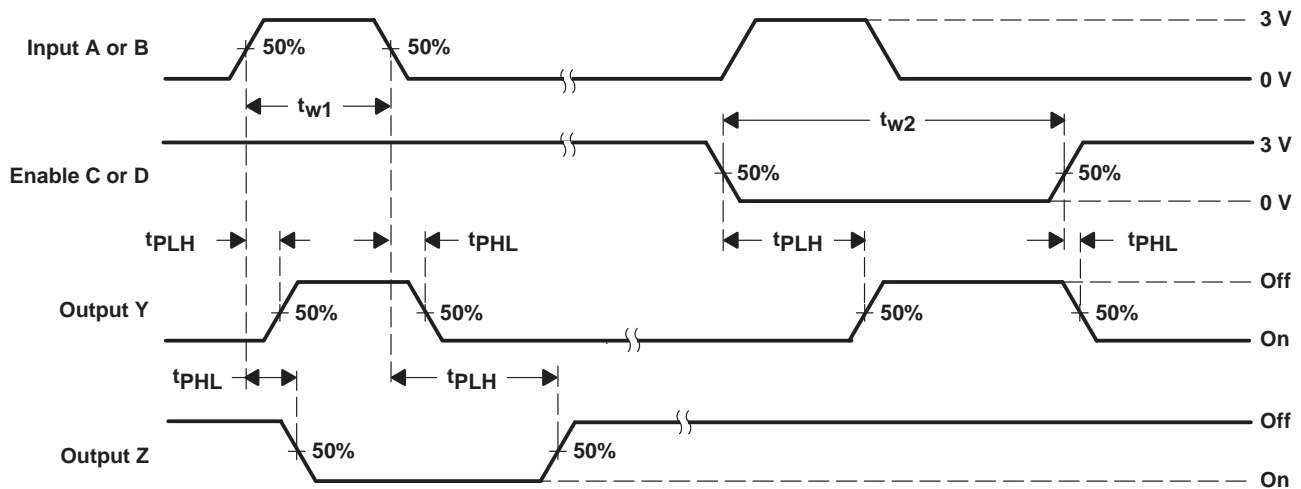

VOLTAGE WAVEFORMS

- NOTES: A. C<sub>L</sub> includes probe and jig capacitance.  
 B. The pulse generators have the following characteristics: Z<sub>O</sub> = 50 Ω, t<sub>r</sub> = t<sub>f</sub> = 10 ± 5 ns, t<sub>w1</sub> = 500 ns, PRR ≤ 1 MHz, t<sub>w2</sub> = 1 μs, PRR ≤ 500 kHz.  
 C. For simplicity, only one channel and the enable connections are shown.

Figure 1. Test Circuit and Voltage Waveforms

# SN55110A, SN75110A, SN75112 DUAL LINE DRIVERS

SLLS106E – DECEMBER 1975 – REVISED APRIL 2000

## TYPICAL CHARACTERISTICS

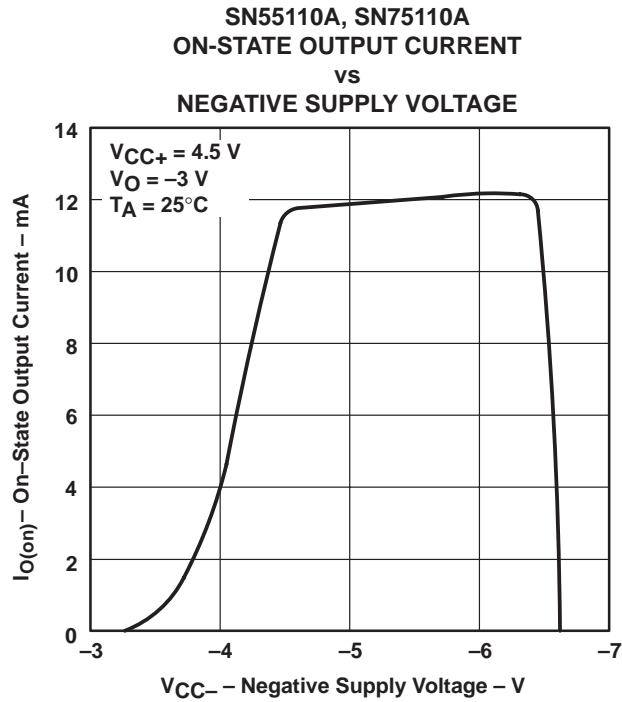

Figure 2

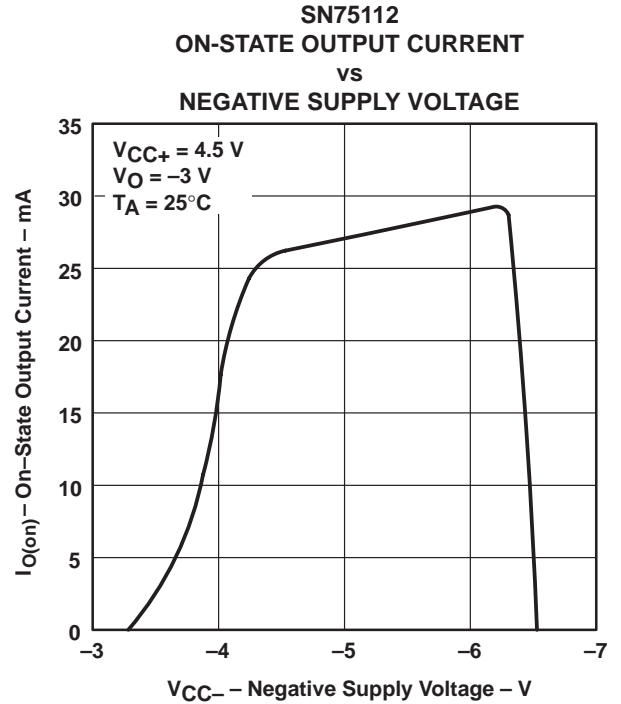

Figure 3

# SN55110A, SN75110A, SN75112 DUAL LINE DRIVERS

SLLS106E – DECEMBER 1975 – REVISED APRIL 2000

## APPLICATION INFORMATION

### special pulse-control circuit

Figure 4 shows a circuit that can be used as a pulse-generator output or in many other testing applications.

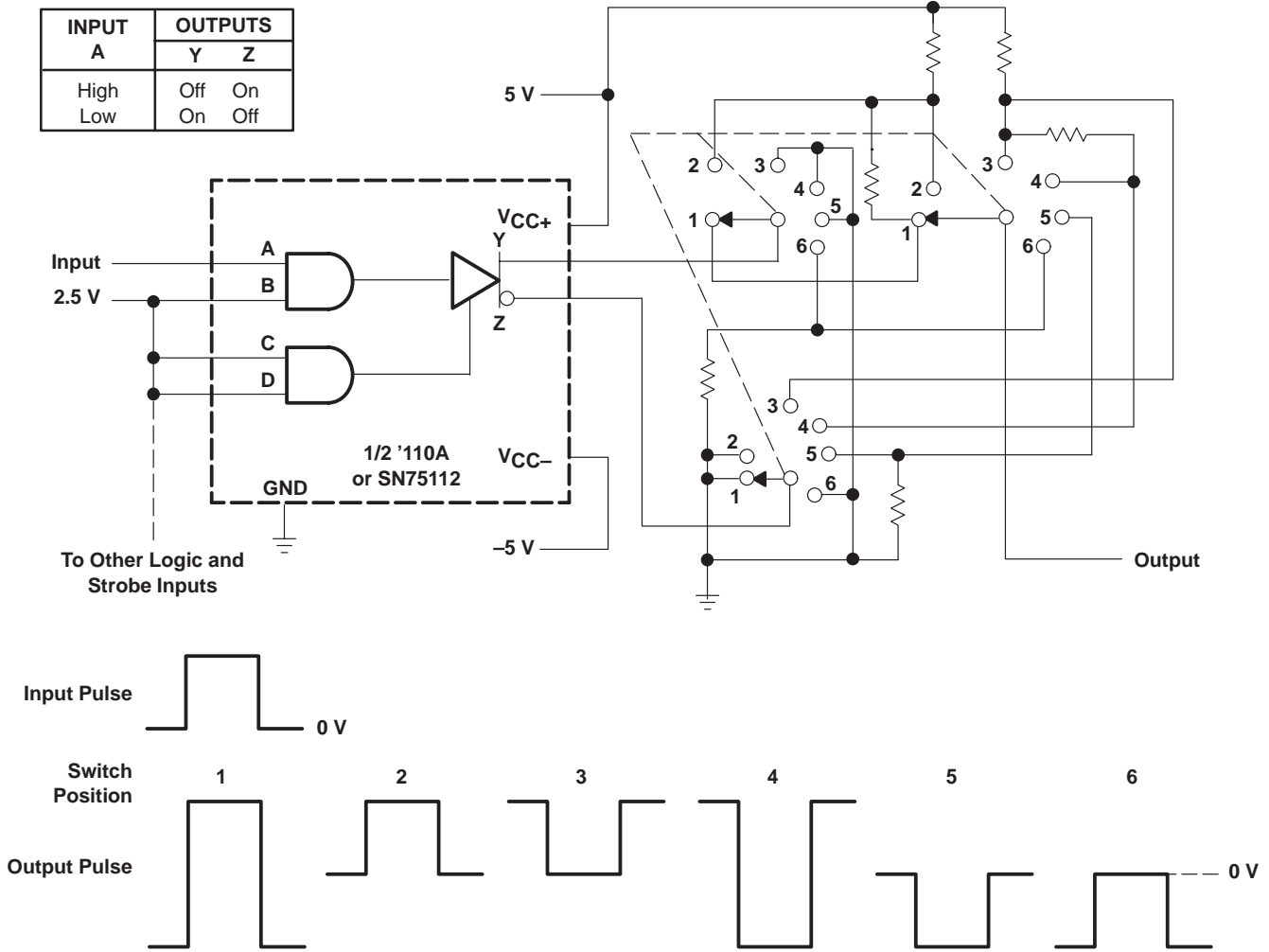

Figure 4. Pulse-Control Circuit



## APPLICATION INFORMATION

### using the SN75112 as a CCITT-recommended V.35 line driver

The SN75112 dual line driver, the SN75107A dual line receiver, and some external resistors can be used to implement the data interchange circuit of CCITT recommendation V.35 (1976) modem specification. The circuit of one channel is shown in Figure 1 and meets the requirement of the interface as specified by Appendix 11 of CCITT V.35 and summarized in Table 1 (V.35 has been replaced by ITU V.11).

**Table 1. CCITT V.35 Electrical Requirements**

GENERATOR	MIN	MAX	UNIT
Source impedance, $Z_{source}$	50	150	$\Omega$
Resistance to ground, R	135	165	$\Omega$
Differential output voltage, $V_{OD}$	440	660	mV
10% to 90% rise time, $t_r$	40		ns
or	$0.01 \times ui^\dagger$		
Common-mode output voltage, $V_{OC}$	-0.6	0.6	V
LOAD (RECEIVER)	MIN	MAX	UNIT
Input impedance, $Z_I$	90	110	$\Omega$
Resistance to ground, R	135	165	$\Omega$

$\dagger ui$  = unit interval or minimum signal-element pulse duration

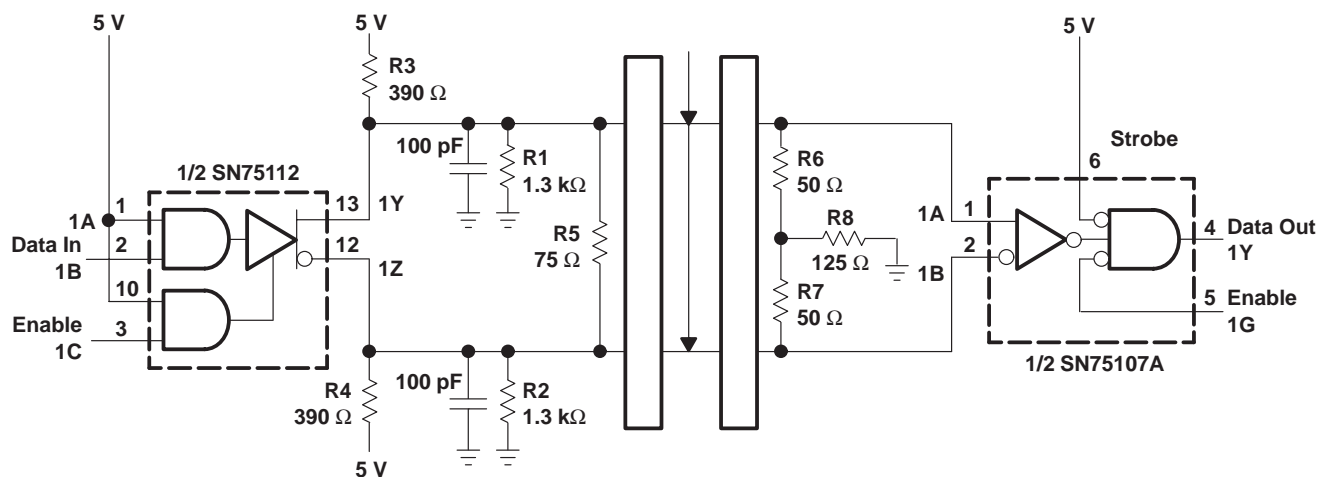

All resistors are 5%, 1/4 W.

**Figure 5. CCITT-Recommended V.35 Interface Using the SN75112 and SN75107A**

## **IMPORTANT NOTICE**

Texas Instruments and its subsidiaries (TI) reserve the right to make changes to their products or to discontinue any product or service without notice, and advise customers to obtain the latest version of relevant information to verify, before placing orders, that information being relied on is current and complete. All products are sold subject to the terms and conditions of sale supplied at the time of order acknowledgment, including those pertaining to warranty, patent infringement, and limitation of liability.

TI warrants performance of its semiconductor products to the specifications applicable at the time of sale in accordance with TI's standard warranty. Testing and other quality control techniques are utilized to the extent TI deems necessary to support this warranty. Specific testing of all parameters of each device is not necessarily performed, except those mandated by government requirements.

Customers are responsible for their applications using TI components.

In order to minimize risks associated with the customer's applications, adequate design and operating safeguards must be provided by the customer to minimize inherent or procedural hazards.

TI assumes no liability for applications assistance or customer product design. TI does not warrant or represent that any license, either express or implied, is granted under any patent right, copyright, mask work right, or other intellectual property right of TI covering or relating to any combination, machine, or process in which such semiconductor products or services might be or are used. TI's publication of information regarding any third party's products or services does not constitute TI's approval, warranty or endorsement thereof.