



LT1107

# Micropower DC/DC Converter Adjustable and Fixed 5V, 12V

## FEATURES

- Operates at Supply Voltages from 2V to 30V
- Consumes Only 320µA Supply Current
- Works in Step-Up or Step-Down Mode
- Only Three External Components Required
- Low-Battery Detector Comparator On-Chip
- User Adjustable Current Limit
- Internal 1A Power Switch
- Fixed or Adjustable Output Voltage Versions
- Space Saving 8-Pin MiniDIP or SO-8 Package

## APPLICATIONS

- Palmtop Computers
- 3V to 5V, 5V to 12V Converters
- 24V to 5V, 12V to 5V Converters
- LCD Bias Generators
- Peripherals and Add-On Cards
- Battery Backup Supplies
- Cellular Telephones
- Portable Instruments

## DESCRIPTION

The LT1107 is a versatile micropower DC/DC converter. The device requires only three external components to deliver a fixed output of 5V or 12V. Supply voltage ranges from 2V to 12V in step-up mode and to 30V in step-down mode. The LT1107 functions equally well in step-up, step-down, or inverting applications.

The LT1107 is pin-for-pin compatible with the LT1111, but has a duty cycle of 70%, resulting in increased output current in many applications. The LT1107 can deliver 150mA at 5V from a 2AA cell input and 5V at 300mA from 24V in step-down mode. Quiescent current is just 320µA, making the LT1107 ideal for power-conscious battery-operated systems. The 63kHz oscillator is optimized to work with surface mount inductors and capacitors.

Switch current limit can be programmed with a single resistor. An auxiliary gain block can be configured as a low-battery detector, linear post regulator, undervoltage lock-out circuit, or error amplifier.

## TYPICAL APPLICATION

Palmtop Computer Logic Supply

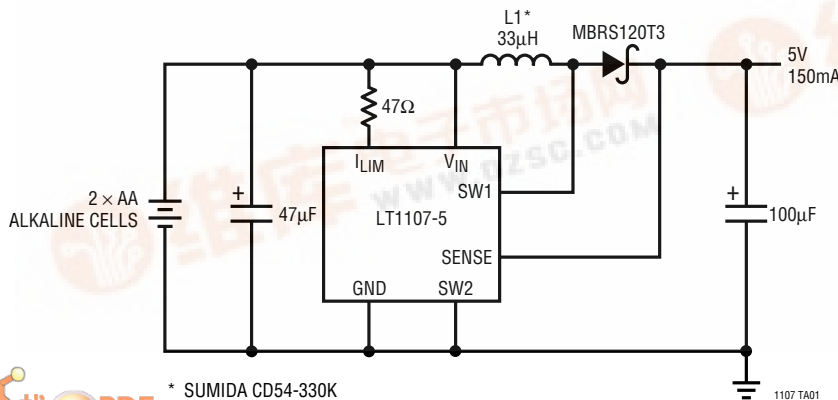

\* SUMIDA CD54-330K  
COILCRAFT DT3316-473

Efficiency

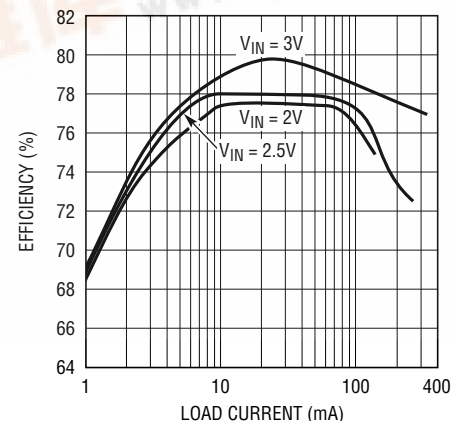

# LT1107

## ABSOLUTE MAXIMUM RATINGS

Supply Voltage ( $V_{IN}$ ) .....	36V	Maximum Switch Current .....	1.5A
SW1 Pin Voltage ( $V_{SW1}$ ) .....	50V	Operating Temperature Range	
SW2 Pin Voltage ( $V_{SW2}$ ) .....	-0.5V to $V_{IN}$	LT1107C .....	0°C to 70°C
Feedback Pin Voltage (LT1107) .....	5V	LT1107M .....	-55°C to 125°C
Sense Pin Voltage (LT1107-5, LT1107-12) .....	36V	Storage Temperature Range .....	-65°C to 150°C
Maximum Power Dissipation .....	500mW	Lead Temperature (Soldering, 10 sec) .....	300°C
Set Pin Voltage .....	5.5V		

## PACKAGE/ORDER INFORMATION

<p>J8 PACKAGE 8-LEAD CERAMIC DIP</p> <p>N8 PACKAGE 8-LEAD PLASTIC DIP</p> <p>* FIXED VERSIONS</p> <p><math>T_{JMAX} = 150^{\circ}\text{C}</math>, <math>\theta_{JA} = 120^{\circ}\text{C/W}</math> (J)  <math>T_{JMAX} = 90^{\circ}\text{C}</math>, <math>\theta_{JA} = 130^{\circ}\text{C/W}</math> (N)</p>	ORDER PART NUMBER	<p>S8 PACKAGE 8-LEAD PLASTIC SO</p> <p>*FIXED VERSIONS</p> <p><math>T_{JMAX} = 90^{\circ}\text{C}</math>, <math>\theta_{JA} = 150^{\circ}\text{C/W}</math></p>	ORDER PART NUMBER
	LT1107CN8 LT1107CN8-5 LT1107CN8-12 LT1107MJ8 LT1107MJ8-5 LT1107MJ8-12		LT1107CS8 LT1107CS8-5 LT1107CS8-12
S8 PART MARKING		1107 11075 110712	

## ELECTRICAL CHARACTERISTICS

$V_{IN} = 3V$ , military or commercial version,  $T_A = 25^{\circ}\text{C}$ , unless otherwise noted.

SYMBOL	PARAMETER	CONDITIONS	MIN	TYP	MAX	UNITS	
$I_Q$	Quiescent Current	Switch OFF		320	450	$\mu\text{A}$	
	Quiescent Current, Step-Up Mode Configuration	No Load		360 550		$\mu\text{A}$ $\mu\text{A}$	
$V_{IN}$	Input Voltage	Step-Up Mode	●	2	12.6	V	
		Step-Down Mode	●		30.0	V	
	Comparator Trip Point Voltage	LT1107 (Note 1)	●	1.2	1.25	1.3	V
$V_{OUT}$	Output Sense Voltage	LT1107-5 (Note 2)	●	4.75	5	5.25	V
		LT1107-12 (Note 2)	●	11.40	12	12.60	V
	Comparator Hysteresis	LT1107	●		8	12.5	mV
	Output Hysteresis	LT1107-5	●		32	50	mV
		LT1107-12	●		75	120	mV
$f_{OSC}$	Oscillator Frequency			50	63	77	kHz
	Duty Cycle, Step-Up Mode	Full Load		64	70	76	%
$t_{ON}$	Switch ON Time, Step-Up Mode	$I_{LIM}$ Tied to $V_{IN}$		8.8	11	12.7	$\mu\text{s}$
	Feedback Pin Bias Current	LT1107, $V_{FB} = 0V$	●		70	120	nA
	Set Pin Bias Current	$V_{SET} = V_{REF}$	●		70	300	nA
$V_{OL}$	Gain Block Output Low	$I_{SINK} = 300\mu\text{A}$ , $V_{SET} = 1V$	●		0.15	0.4	V
	Reference Line Regulation	$5V \leq V_{IN} \leq 30V$	●		0.02	0.075	%/V

## ELECTRICAL CHARACTERISTICS

$V_{IN} = 3V$ , military or commercial version,  $T_A = 25^\circ C$ , unless otherwise noted.

SYMBOL	PARAMETER	CONDITIONS	MIN	TYP	MAX	UNITS
$A_V$	Gain Block Gain	$R_L = 100k$ (Note 3)	●	1000	6000	V/V
	Current Limit	$220\Omega$ to $I_{LIM}$ to $V_{IN}$		400		mA
	Current Limit Temperature Coefficient		●	-0.3		%/ $^\circ C$
$V_{SW2}$	Switch OFF Leakage Current	Measured at SW1 Pin, $V_{SW1} = 12V$		1	10	$\mu A$
	Maximum Excursion Below GND	$I_{SW1} \leq 10\mu A$ , Switch OFF		-400	-350	mV

$V_{IN} = 3V$ ,  $-55^\circ C \leq T_A \leq 125^\circ C$ , unless otherwise noted.

SYMBOL	PARAMETER	CONDITIONS	MIN	LT1107M TYP	MAX	UNITS	
$I_Q$	Quiescent Current	Switch OFF	●		500	$\mu A$	
$f_{OSC}$	Oscillator Frequency		●	40	63	95	kHz
DC	Duty Cycle	Step-Up Mode	●	56	69	81	%
		Step-Down Mode, $V_{IN} = 12V$	●	45	60	73	%
$t_{ON}$	Switch ON Time	Step-Up Mode	●	7	11	15	$\mu s$
		Step-Down Mode, $V_{IN} = 12V$	●	5	9	13	$\mu s$
$V_{SAT}$	Reference Line Regulation	$2V \leq V_{IN} \leq 5V$ , $0^\circ C \leq T_A \leq 125^\circ C$			0.2	0.4	%/V
		$2.4V \leq V_{IN} \leq 5V$ , $T_A = -55^\circ C$				0.8	%/V
$V_{SAT}$	Switch Saturation Voltage, Step-Up Mode	$0^\circ C \leq T_A \leq 125^\circ C$ , $I_{SW} = 500mA$ $T_A = -55^\circ C$ , $I_{SW} = 400mA$			0.5	0.65	V
	Switch Saturation Voltage, Step-Down Mode	$V_{IN} = 12V$ , $I_{SW} = 500mA$ $0^\circ C \leq T_A \leq 125^\circ C$ $T_A = -55^\circ C$			0.5	0.65	V
						1.5	V
						2.0	V

$V_{IN} = 3V$ ,  $0^\circ C \leq T_A \leq 70^\circ C$ , unless otherwise noted.

SYMBOL	PARAMETER	CONDITIONS	MIN	LT1107C TYP	MAX	UNITS	
$I_Q$	Quiescent Current	Switch OFF	●		450	$\mu A$	
$f_{OSC}$	Oscillator Frequency		●	50	63	88	kHz
DC	Duty Cycle	Step-Up Mode	●	62	69	78	%
		Step-Down Mode, $V_{IN} = 12V$	●	50	60	70	%
$t_{ON}$	Switch ON Time	Step-Up Mode	●	8	11	13.5	$\mu s$
		Step-Down Mode, $V_{IN} = 12V$	●	6	9	12.0	$\mu s$
	Reference Line Regulation	$2V \leq V_{IN} \leq 5V$	●		0.2	0.7	%/V
$V_{SAT}$	Switch Saturation Voltage, Step-Up Mode	$V_{IN} = 3V$ , $I_{SW} = 650mA$	●		0.5	0.65	V
	Switch Saturation Voltage, Step-Down Mode	$V_{IN} = 12V$ , $I_{SW} = 650mA$	●		1.1	1.5	V

The ● denotes specifications which apply over the full operating temperature range.

**Note 1:** This specification guarantees that both the high and low trip points of the comparator fall within the 1.2V to 1.3V range.

**Note 2:** The output voltage waveform will exhibit a sawtooth shape due to the comparator hysteresis. The output voltage on the fixed-output versions will always be within the specified range.

**Note 3:** 100k resistor connected between a 5V source and the AO pin.

# TYPICAL PERFORMANCE CHARACTERISTICS

**Saturation Voltage, Step-Up Mode (SW2 Pin Grounded)**

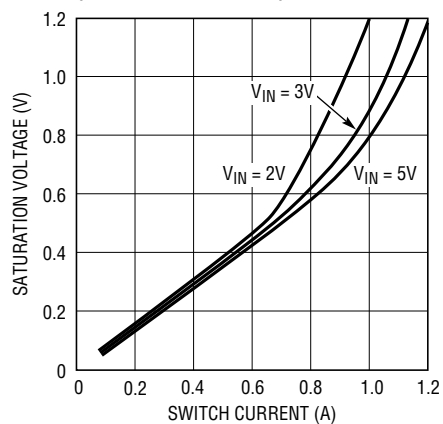

1107 G01

**Switch ON Voltage, Step-Down Mode (SW1 Pin Connected to VIN)**

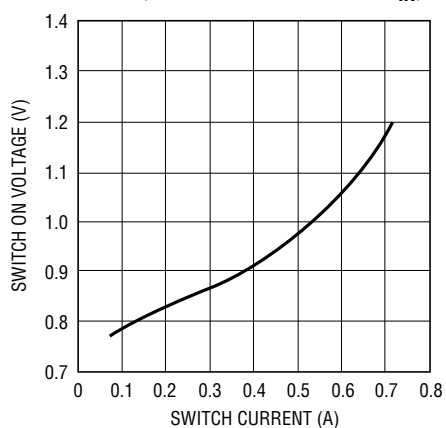

1107 G02

**Maximum Switch Current vs R<sub>LIM</sub>**

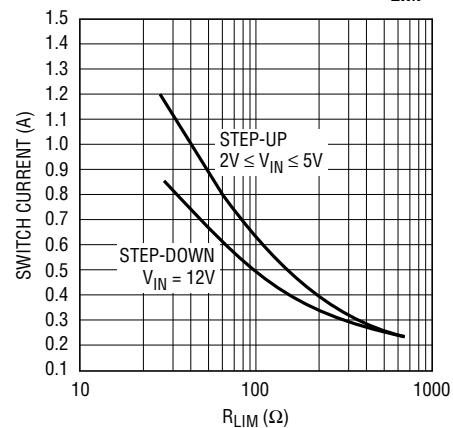

1107 G03

**Quiescent Current**

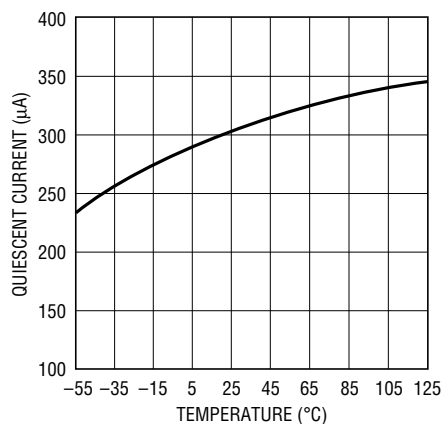

1107 G05

**Quiescent Current**

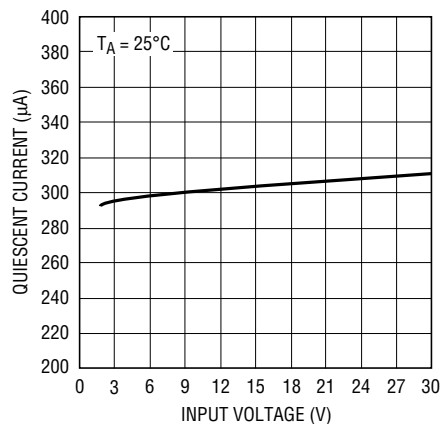

1107 G06

**Oscillator Frequency**

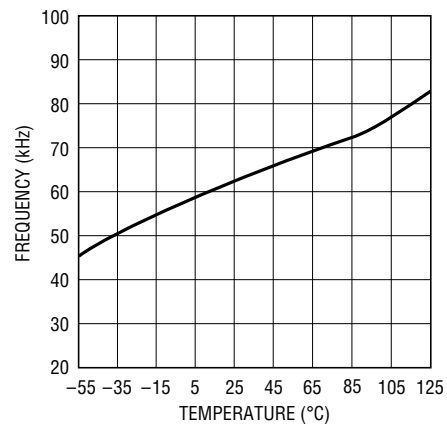

1107 G07

**Switch ON Time Step-Up Mode**

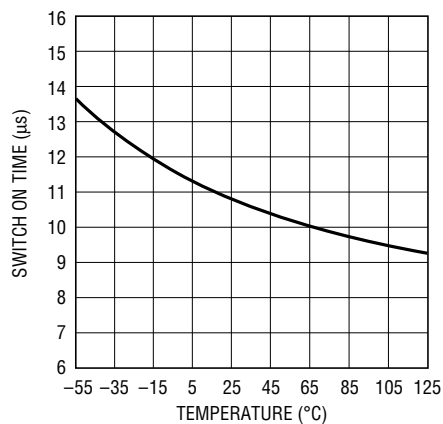

1107 G08

**Duty Cycle Step-Up Mode**

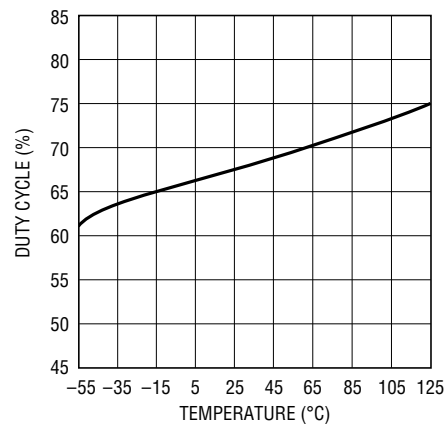

1107 G09

**Switch ON Time Step-Down Mode**

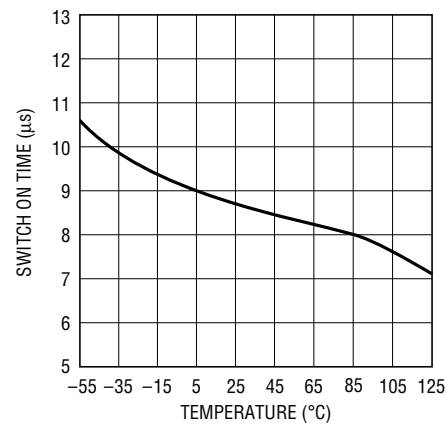

1107 G10

## TYPICAL PERFORMANCE CHARACTERISTICS

Minimum/Maximum Frequency vs ON Time, Step-Down Mode

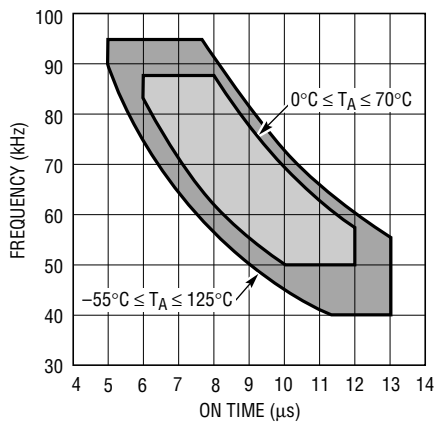

1107 G11

Minimum/Maximum Frequency vs ON Time, Step-Up Mode

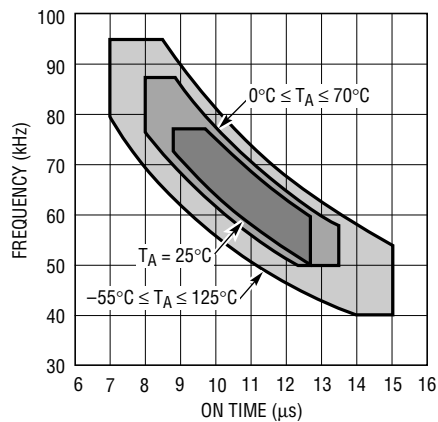

1107 G12

Duty Cycle Step-Down Mode

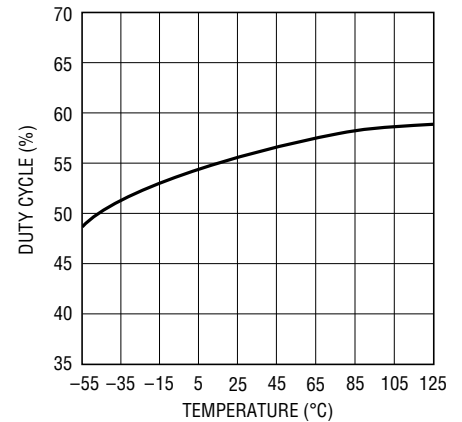

1107 G13

LT1107-5 Output Voltage

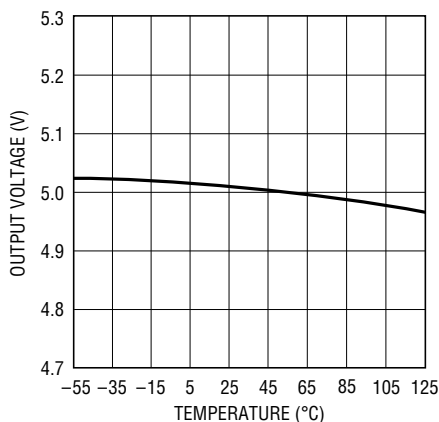

1107 G16

LT1107-12 Output Voltage

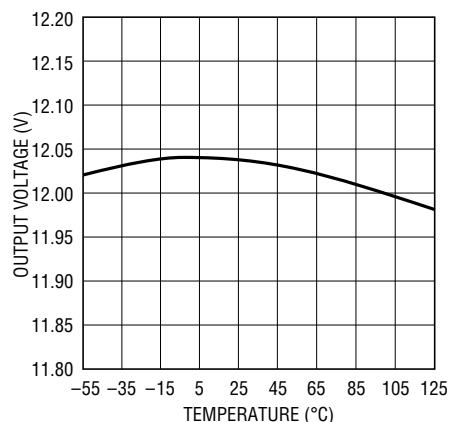

1107 G17

LT1107 Feedback Voltage

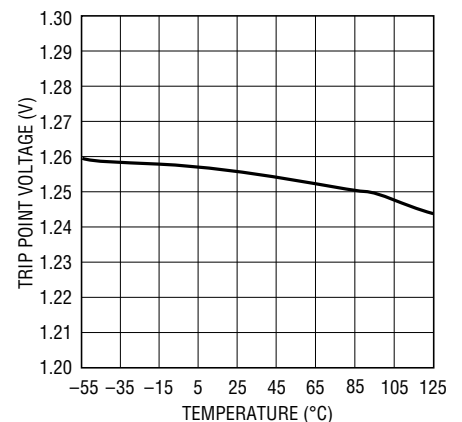

1107 G18

## PIN FUNCTIONS

**I<sub>LIM</sub> (Pin 1):** Connect this pin to  $V_{IN}$  for normal use. Where lower current limit is desired, connect a resistor between  $I_{LIM}$  and  $V_{IN}$ . A 220Ω resistor will limit the switch current to approximately 400mA.

**$V_{IN}$  (Pin 2):** Input Supply Voltage.

**SW1 (Pin 3):** Collector of Power Transistor. For step-up mode connect to inductor/diode. For step-down mode connect to  $V_{IN}$ .

**SW2 (Pin 4):** Emitter of Power Transistor. For step-up mode connect to ground. For step-down mode connect to inductor/diode. This pin must never be allowed to go more than a Schottky diode drop below ground.

**GND (Pin 5):** Ground.

**AO (Pin 6):** Auxiliary Gain Block (GB) Output. Open collector, can sink 300μA.

**SET (Pin 7):** GB Input. GB is an op amp with positive input connected to SET pin and negative input connected to 1.25V reference.

**FB/SENSE (Pin 8):** On the LT1107 (adjustable), this pin goes to the comparator input. On the LT1107-5 and LT1107-12, this pin goes to the internal application resistor that sets output voltage.

# LT1107

## BLOCK DIAGRAMS

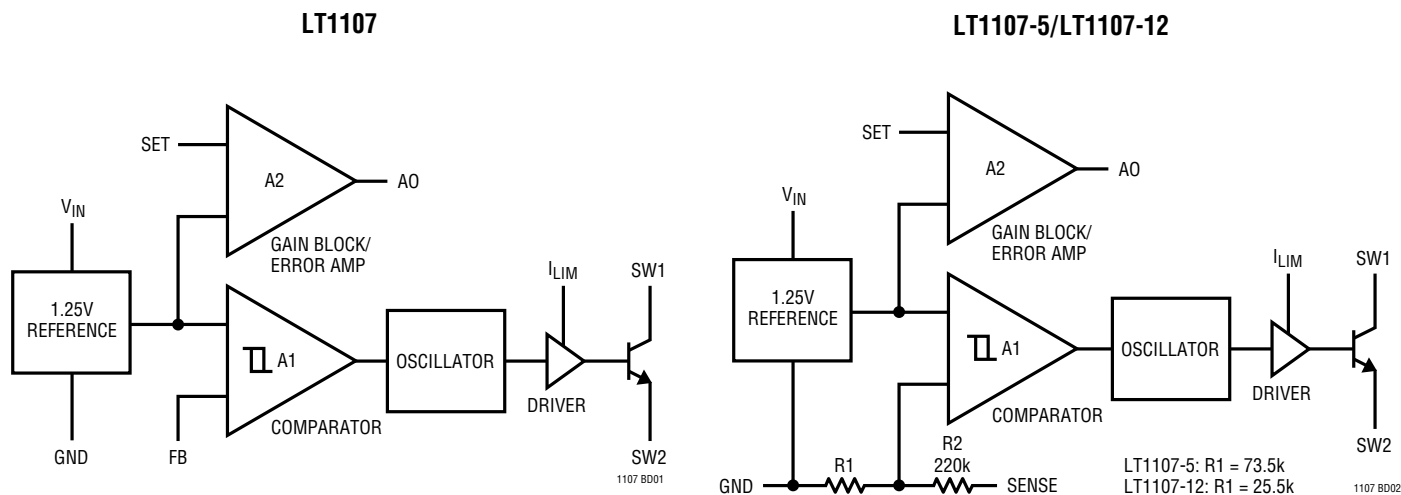

## OPERATION

The LT1107 is a gated oscillator switcher. This type architecture has very low supply current because the switch is cycled when the feedback pin voltage drops below the reference voltage. Circuit operation can best be understood by referring to the LT1107 block diagram. Comparator A1 compares the feedback (FB) pin voltage with the 1.25V reference signal. When FB drops below 1.25V, A1 switches on the 63kHz oscillator. The driver amplifier boosts the signal level to drive the output NPN power switch. The switch cycling action raises the output voltage and FB pin voltage. When the FB voltage is sufficient to trip A1, the oscillator is gated off. A small amount of hysteresis built into A1 ensures loop stability without external frequency compensation. When the comparator output is low, the oscillator and all high current circuitry is turned off, lowering device quiescent current to just 300 $\mu$ A.

The oscillator is set internally for 11 $\mu$ s ON time and 5 $\mu$ s OFF time in step-up mode, optimizing the device for converters where  $V_{OUT} \approx 3V_{IN}$ . The combination of high duty cycle and the current limit feature enables continuous mode operation in many applications, increasing available output power.

Gain block A2 can serve as a low-battery detector. The negative input of A2 is the 1.25V reference. A resistor divider from  $V_{IN}$  to GND, with the mid-point connected to the SET pin provides the trip voltage in a low-battery detector application. AO can sink 300 $\mu$ A (use a 22k resistor pull-up to 5V).

A resistor connected between the  $I_{LIM}$  pin and  $V_{IN}$  sets maximum switch current. When the switch current exceeds the set value, the switch cycle is prematurely terminated. If current limit is not used,  $I_{LIM}$  should be tied directly to  $V_{IN}$ . Propagation delay through the current limit circuitry is approximately 1 $\mu$ s.

In step-up mode the switch emitter (SW2) is connected to ground and the switch collector (SW1) drives the inductor; in step-down mode the collector is connected to  $V_{IN}$  and the emitter drives the inductor.

The LT1107-5 and LT1107-12 are functionally identical to the LT1107. The -5 and -12 versions have on-chip voltage setting resistors for fixed 5V or 12V outputs. Pin 8 on the fixed versions should be connected to the output. No external resistors are needed.

## APPLICATIONS INFORMATION

### Inductor Selection — Step-Up Converter

In a step-up, or boost converter (Figure 1), power generated by the inductor makes up the difference between input and output. Power required from the inductor is determined by:

$$P_L = (V_{OUT} + V_D - V_{IN(MIN)}) (I_{OUT}) \quad (01)$$

where  $V_D$  is the diode drop (0.5V for a 1N5818 Schottky). Energy required by the inductor per cycle must be equal or greater than:

$$P_L / f_{OSC} \quad (02)$$

in order for the converter to regulate the output.

When the switch is closed, current in the inductor builds according to:

$$I_L(t) = \frac{V_{IN}}{R'} \left( 1 - e^{-\frac{R't}{L}} \right) \quad (03)$$

where  $R'$  is the sum of the switch equivalent resistance (0.8Ω typical at 25°C) and the inductor DC resistance. When the drop across the switch is small compared to  $V_{IN}$ , the simple lossless equation:

$$I_L(t) = \frac{V_{IN}}{L} t \quad (04)$$

can be used. These equations assume that at  $t = 0$ , inductor current is zero. This situation is called “discontinuous mode operation” in switching regulator parlance. Setting “t” to the switch ON time from the LT1107 specification table (typically 11μs) will yield  $I_{PEAK}$  for a specific “L” and  $V_{IN}$ . Once  $I_{PEAK}$  is known, energy in the inductor at the end of the switch ON time can be calculated as:

$$E_L = \frac{1}{2} L I_{PEAK}^2 \quad (05)$$

$E_L$  must be greater than  $P_L / f_{OSC}$  for the converter to deliver the required power. For best efficiency  $I_{PEAK}$  should be kept to 1A or less. Higher switch currents will cause excessive drop across the switch resulting in reduced efficiency. In general, switch current should be held to as low a value as possible in order to keep switch, diode and inductor losses at a minimum.

As an example, suppose 12V at 60mA is to be generated from a 3V to 6V input. Recalling equation (01),

$$P_L = (12V + 0.5V - 3V)(60mA) = 570mW \quad (06)$$

Energy required from the inductor is:

$$\frac{P_L}{f_{OSC}} = \frac{570mW}{63kHz} = 9.05\mu J \quad (07)$$

Picking an inductor value of 33μH with 0.2Ω DCR results in a peak switch current of:

$$I_{PEAK} = \frac{3V}{1\Omega} \left( 1 - e^{-\frac{1\Omega \times 11\mu s}{33\mu H}} \right) = 850mA \quad (08)$$

Substituting  $I_{PEAK}$  into Equation 04 results in:

$$E_L = \frac{1}{2} (33\mu H) (0.85A)^2 = 11.91\mu J \quad (09)$$

Since 11.9μJ > 9.05μJ, the 33μH inductor will work. This trial-and-error approach can be used to select the optimum inductor.

A resistor can be added in series with the  $I_{LIM}$  pin to invoke switch current limit. The resistor should be picked so the calculated  $I_{PEAK}$  at minimum  $V_{IN}$  is equal to the Maximum Switch Current (from Typical Performance Characteristic curves). Then, as  $V_{IN}$  increases, peak switch current is held constant, resulting in increasing efficiency.

### Inductor Selection — Step-Down Converter

The step-down case (Figure 2) differs from the step-up in that the inductor current flows through the load during both the charge and discharge periods of the inductor. Current through the switch should be limited to ~650mA in this mode. Higher current can be obtained by using an external switch (see LT1111 and LT1110 data sheets). The  $I_{LIM}$  pin is the key to successful operation over varying inputs.

After establishing output voltage, output current and input voltage range, peak switch current can be calculated by the formula:

$$I_{PEAK} = \frac{2I_{OUT}}{DC} \left[ \frac{V_{OUT} + V_D}{V_{IN} - V_{SW} + V_D} \right] \quad (10)$$

## APPLICATIONS INFORMATION

where DC = duty cycle (0.50 in step-down mode)

$V_{SW}$  = switch drop in step-down mode

$V_D$  = diode drop (0.5V for a 1N5818)

$I_{OUT}$  = output current

$V_{OUT}$  = output voltage

$V_{IN}$  = minimum input voltage

$V_{SW}$  is actually a function of switch current which is in turn a function of  $V_{IN}$ , L, time, and  $V_{OUT}$ . To simplify, 1.5V can be used for  $V_{SW}$  as a very conservative value.

Once  $I_{PEAK}$  is known, inductor value can be derived from:

$$L = \frac{V_{IN(MIN)} - V_{SW} - V_{OUT}}{I_{PEAK}} \times t_{ON} \quad (11)$$

where  $t_{ON}$  = switch ON time (7 $\mu$ s).

Next, the current limit resistor  $R_{LIM}$  is selected to give  $I_{PEAK}$  from the Maximum Switch Current vs  $R_{LIM}$  curve. The addition of this resistor keeps maximum switch current constant as the input voltage is increased.

As an example, suppose 5V at 300mA is to be generated from a 12V to 24V input. Recalling Equation (10):

$$I_{PEAK} = \frac{2(300mA)}{0.50} \left[ \frac{5 + 0.5}{12 - 1.5 + 0.5} \right] = 600mA \quad (12)$$

Next, inductor value is calculated using Equation (11):

$$L = \frac{12 - 1.5 - 5}{600mA} 7\mu s = 64\mu H \quad (13)$$

Use the next lowest standard value (56 $\mu$ H).

Then pick  $R_{LIM}$  from the curve. For  $I_{PEAK} = 600mA$ ,  $R_{LIM} = 56\Omega$ .

### Inductor Selection — Positive-to-Negative Converter

Figure 4 shows hookup for positive-to-negative conversion. All of the output power must come from the inductor. In this case,

$$P_L = (|V_{OUT}| + V_D)(I_{OUT}) \quad (14)$$

In this mode the switch is arranged in common collector or step-down mode. The switch drop can be modeled as a 0.75V source in series with a 0.65 $\Omega$  resistor. When the switch closes, current in the inductor builds according to:

$$I_L(t) = \frac{V_L}{R'} \left( 1 - e^{-\frac{R't}{L}} \right) \quad (15)$$

where  $R' = 0.65\Omega + DCR_L$

$$V_L = V_{IN} - 0.75V$$

As an example, suppose -5V at 50mA is to be generated from a 4.5V to 5.5V input. Recalling Equation (14),

$$P_L = (|-5V| + 0.5V)(50mA) = 275mW \quad (16)$$

Energy required from the inductor is:

$$\frac{P_L}{f_{OSC}} = \frac{275mW}{63kHz} = 4.4\mu J \quad (17)$$

Picking an inductor value of 100 $\mu$ H with 0.2 $\Omega$  DCR results in a peak switch current of:

$$I_{PEAK} = \frac{(4.5V - 0.75V)}{(0.65\Omega + 0.2\Omega)} \left( 1 - e^{-\frac{0.85\Omega \times 9\mu s}{100\mu H}} \right) = 325mA \quad (18)$$

Substituting  $I_{PEAK}$  into Equation (04) results in:

$$E_L = \frac{1}{2} (100\mu H) (0.325A)^2 = 5.28\mu J \quad (19)$$

Since 5.28 $\mu$ J > 3.82 $\mu$ J, the 100 $\mu$ H inductor will work.

With this relatively small input range,  $R_{LIM}$  is not usually necessary and the  $I_{LIM}$  pin can be tied directly to  $V_{IN}$ . As in the step-down case, peak switch current should be limited to ~650mA.

### Step-Up (Boost Mode) Operation

A step-up DC/DC converter delivers an output voltage higher than the input voltage. Step-up converters are *not* short-circuit protected since there is a DC path from input to output.



## APPLICATIONS INFORMATION

The usual step-up configuration for the LT1107 is shown in Figure 1. The LT1107 first pulls SW1 low causing  $V_{IN} - V_{CESAT}$  to appear across L1. A current then builds up in L1. At the end of the switch ON time the current in L1 is<sup>1</sup>:

$$I_{PEAK} = \frac{V_{IN}}{L} t_{ON} \quad (20)$$

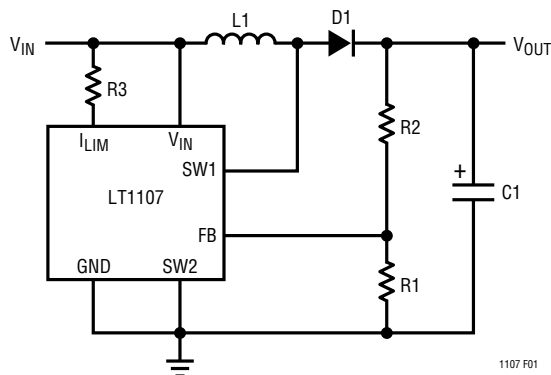

Figure 1. Step-Up Mode Hookup

Immediately after switch turn-off, the SW1 voltage pin starts to rise because current cannot instantaneously stop flowing in L1. When the voltage reaches  $V_{OUT} + V_D$ , the inductor current flows through D1 into C1, increasing  $V_{OUT}$ . This action is repeated as needed by the LT1107 to keep  $V_{FB}$  at the internal reference voltage of 1.25V. R1 and R2 set the output voltage according to the formula:

$$V_{OUT} = \left(1 + \frac{R2}{R1}\right) (1.25V) \quad (21)$$

### Step-Down (Buck Mode) Operation

A step-down DC/DC converter converts a higher voltage to a lower voltage. The usual hookup for an LT1107 based step-down converter is shown in Figure 2.

When the switch turns on, SW2 pulls up to  $V_{IN} - V_{SW}$ . This puts a voltage across L1 equal to  $V_{IN} - V_{SW} - V_{OUT}$ , causing a current to build up in L1. At the end of the switch ON time, the current in L1 is equal to:

$$I_{PEAK} = \frac{V_{IN} - V_{SW} - V_{OUT}}{L} t_{ON} \quad (22)$$

**Note 1:** This simple expression neglects the effects of switch and coil resistance. This is taken into account in the "Inductor Selection" section.

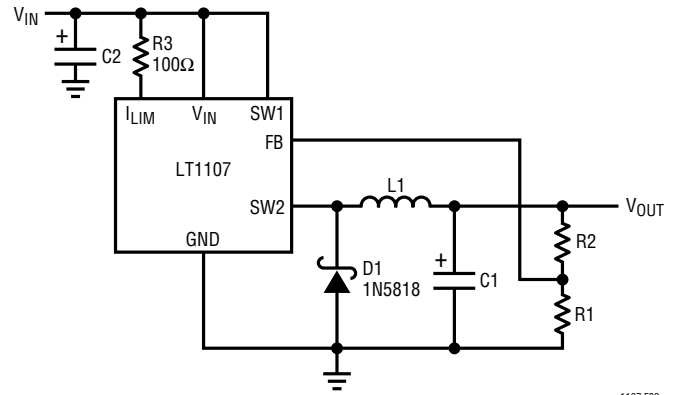

Figure 2. Step-Down Mode Hookup

When the switch turns off, the SW2 pin falls rapidly and actually goes below ground. D1 turns on when SW2 reaches 0.4V below ground. D1 MUST BE A SCHOTTKY DIODE. The voltage at SW2 must never be allowed to go below -0.5V. A silicon diode such as the 1N4933 will allow SW2 to go to -0.8V, causing potentially destructive power dissipation inside the LT1107. Output voltage is determined by:

$$V_{OUT} = \left(1 + \frac{R2}{R1}\right) (1.25V) \quad (23)$$

R3 programs switch current limit. This is especially important in applications where the input varies over a wide range. Without R3, the switch stays on for a fixed time each cycle. Under certain conditions the current in L1 can build up to excessive levels, exceeding the switch rating and/or saturating the inductor. The 100Ω resistor programs the switch to turn off when the current reaches approximately 700mA. When using the LT1107 in step-down mode, output voltage should be limited to 6.2V or less. Higher output voltages can be accommodated by inserting a 1N5818 diode in series with the SW2 pin (anode connected to SW2).

### Inverting Configurations

The LT1107 can be configured as a positive-to-negative converter (Figure 3), or a negative-to-positive converter (Figure 4). In Figure 3, the arrangement is very similar to a step-down, except that the high side of the feedback is referred to ground. This level shifts the output negative. As in the step-down mode, D1 must be a Schottky diode, and

## APPLICATIONS INFORMATION

$|V_{OUT}|$  should be less than 6.2V. More negative output voltages can be accommodated as in the prior section.

In Figure 4, the input is negative while the output is positive. In this configuration, the magnitude of the input voltage can be higher or lower than the output voltage. A level shift, provided by the PNP transistor, supplies proper polarity feedback information to the regulator.

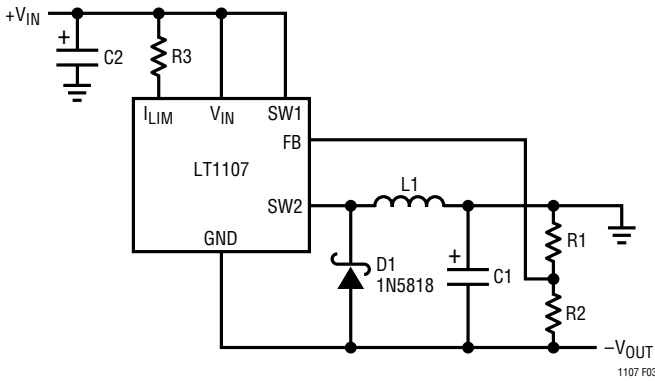

Figure 3. Positive-to-Negative Converter

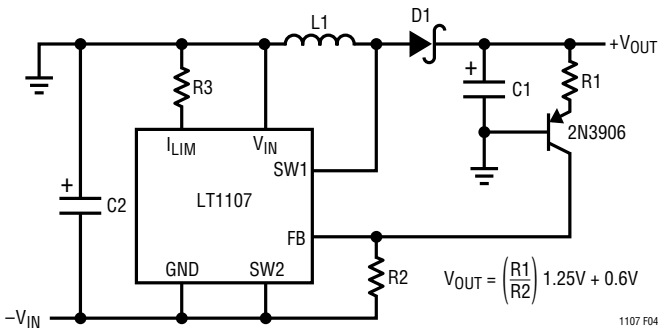

Figure 4. Negative-to-Positive Converter

### Using the $I_{LIM}$ Pin

The LT1107 switch can be programmed to turn off at a set switch current, a feature not found on competing devices. This enables the input to vary over a wide range without exceeding the maximum switch rating or saturating the inductor. Consider the case where analysis shows the LT1107 must operate at an 800mA peak switch current with a 2V input. If  $V_{IN}$  rises to 4V, the peak switch current will rise to 1.6A, exceeding the maximum switch current rating. With the proper resistor selected (see the “Maximum Switch Current vs  $R_{LIM}$ ” characteristic), the switch

current will be limited to 800mA, even if the input voltage increases.

Another situation where the  $I_{LIM}$  feature is useful occurs when the device goes into continuous mode operation. This occurs in step-up mode when:

$$\frac{V_{OUT} + V_{DIODE}}{V_{IN} - V_{SW}} < \frac{1}{1 - DC} \tag{24}$$

When the input and output voltages satisfy this relationship, inductor current does not go to zero during the switch OFF time. When the switch turns on again, the current ramp starts from the non-zero current level in the inductor just prior to switch turn-on. As shown in Figure 5, the inductor current increases to a high level before the comparator turns off the oscillator. This high current can cause excessive output ripple and requires oversizing the output capacitor and inductor. With the  $I_{LIM}$  feature, the switch turns off at the programmed current as shown in Figure 6, keeping output ripple to a minimum.

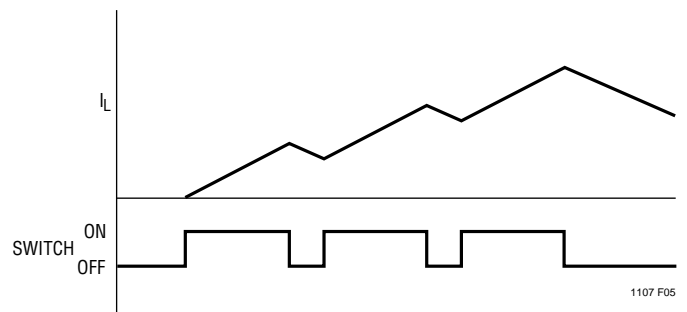

Figure 5. No Current Limit Causes Large Inductor Current Build-Up

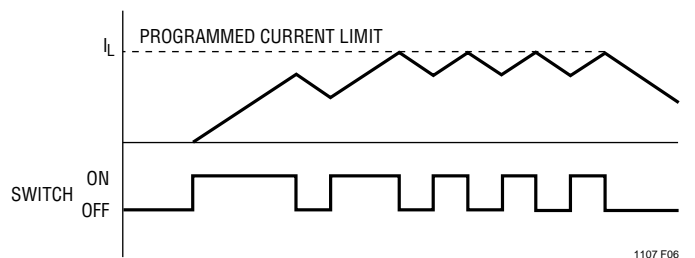

Figure 6. Current Limit Keeps Inductor Current Under Control

## APPLICATIONS INFORMATION

Figure 7 details current limit circuitry. Sense transistor A1, whose base and emitter are paralleled with power switch Q2, is ratioed such that approximately 0.5% of Q2's collector current flows in Q1's collector. This current is passed through internal 80Ω resistor R1 and out through the I<sub>LIM</sub> pin. The value of the external resistor connected between I<sub>LIM</sub> and V<sub>IN</sub> sets the current limit. When sufficient switch current flows to develop a V<sub>BE</sub> across R1 + R<sub>LIM</sub>, Q3 turns on and injects current into the oscillator, turning off the switch. Delay through this circuitry is approximately 800ns. The current trip point becomes less accurate for switch ON times less than 3μs. Resistor values programming switch ON time for 800ns or less will cause spurious response in the switch circuitry although the device will still maintain output regulation.

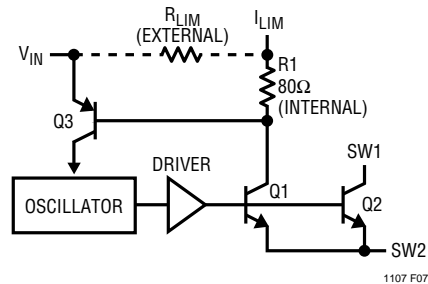

Figure 7. LT1107 Current Limit Circuitry

### Using the Gain Block

The gain block (GB) on the LT1107 can be used as an error amplifier, low-battery detector or linear post regulator. The gain block itself is a very simple PNP input op amp with an open collector NPN output. The negative input of the gain block is tied internally to the 1.25V reference. The positive input comes out on the SET pin.

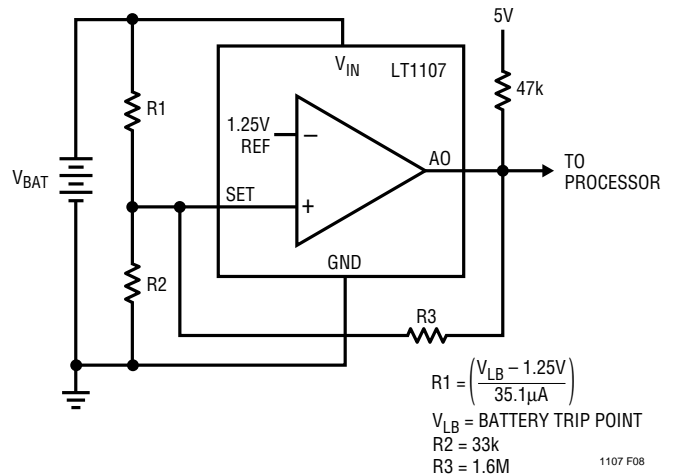

Figure 8. Setting Low-Battery Detector Trip Point

Arrangement of the gain block as a low-battery detector is straightforward. Figure 8 shows hookup. R1 and R2 need only be low enough in value so that the bias current of the SET input does not cause large errors. 33k for R2 is adequate. R3 can be added to introduce a small amount of hysteresis. This will cause the gain block to “snap” when the trip point is reached. Values in the 1M to 10M range are optimal. The addition of R3 will change the trip point, however.

Output ripple of the LT1107, normally 50mV at 5V<sub>OUT</sub> can be reduced significantly by placing the gain block in front of the FB input as shown in Figure 9. This effectively reduces the comparator hysteresis by the gain of the gain block. Output ripple can be reduced to just a few millivolts using this technique. Ripple reduction works with step-down or inverting modes as well. For this technique to be effective, output capacitor C1 must be large, so that each switching cycle increases V<sub>OUT</sub> by only a few millivolts. 1000μF is a good starting value. C1 should be a low ESR type as well.

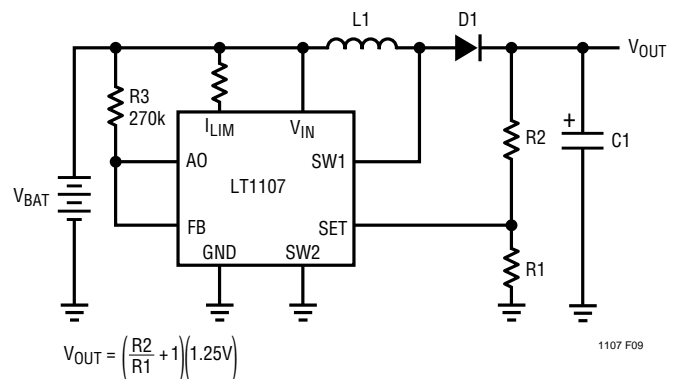
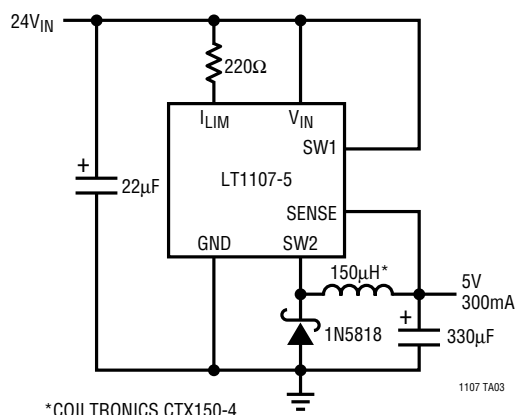

Figure 9. Output Ripple Reduction Using Gain Block

# TYPICAL APPLICATION

24V-to-5V Step-Down Converter



# PACKAGE DESCRIPTION

Dimensions in inches (millimeters) unless otherwise noted.

J8 Package, 8-Lead Ceramic DIP

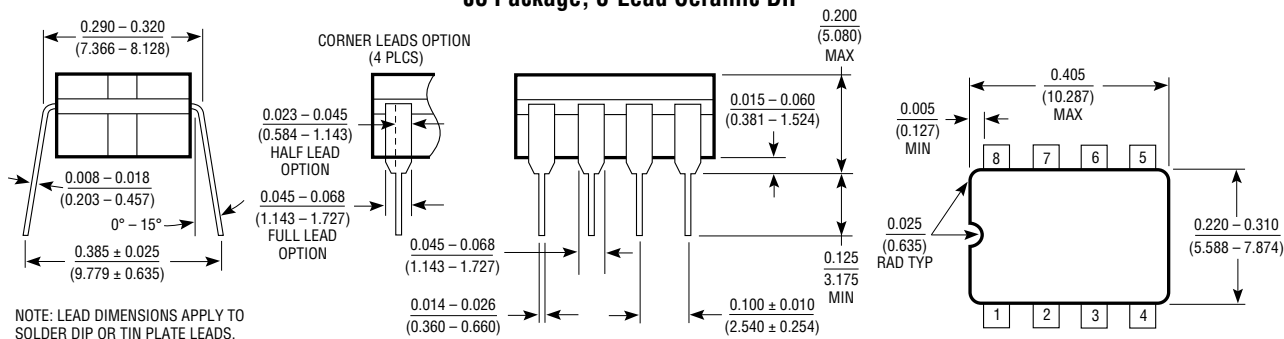

N8 Package, 8-Lead Plastic DIP

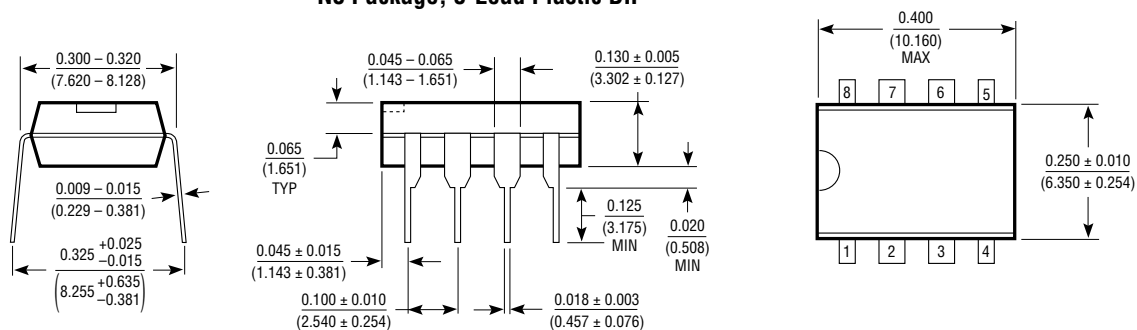

S8 Package, 8-Lead Plastic SOIC

