



# TRIPLE DIFFERENTIAL 2:1 MULTIPLEXER

**SY10E457**  
**SY100E457**

## FEATURES

- Differential D and Q
- Extended 100E VEE range of -4.2V to -5.5V
- VBB output for single-ended use
- 700ps max. propagation delay
- High frequency outputs
- Separate and common select
- Internal 75KΩ input pulldown resistors
- Available in 28-pin PLCC package

## DESCRIPTION

The SY10/100E457 are 3-bit differential 2:1 multiplexers. The fully differential data path makes the devices ideal for multiplexing low skew clock or other skew sensitive signals. Multiple VBB pins are provided to ease AC coupling input signals.

The higher frequency outputs provide the device with a >1.0GHz bandwidth to meet the needs of the most demanding system clock.

Both separate selects and a common select are provided to make the device well suited for both data path and random logic applications.

## BLOCK DIAGRAM

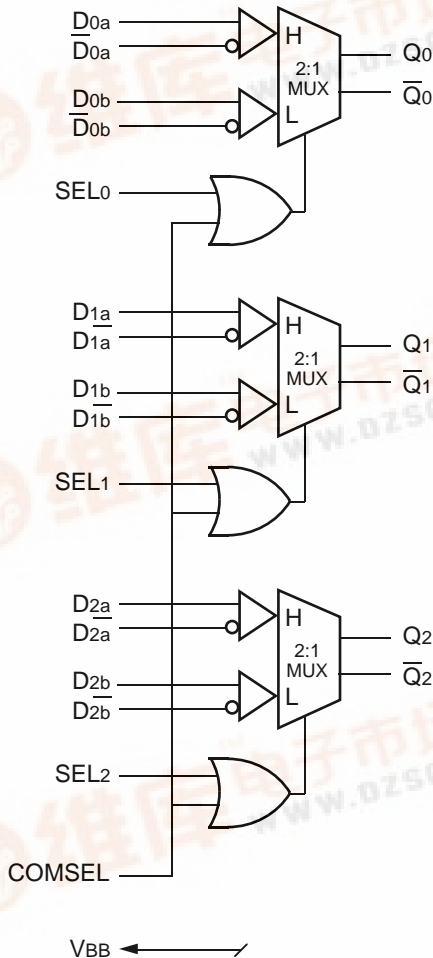

## PIN CONFIGURATION

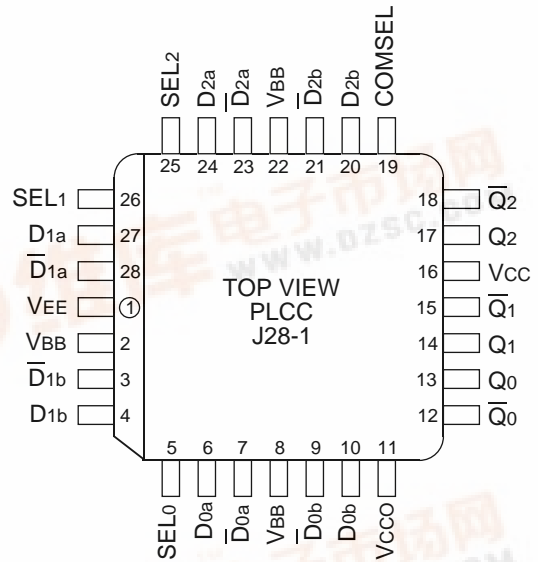

## PIN NAMES

Pin	Function
D <sub>n</sub> [0:2], $\overline{D}_n$ [0:2]	Differential Data Inputs
SEL	Individual Select Input
COMSEL	Common Select Input
VBB	VBB Reference Output
Q[0:2], $\overline{Q}$ [0:2]	Differential Data Outputs
VCCO	Vcc to Output



**DC ELECTRICAL CHARACTERISTICS**V<sub>EE</sub> = V<sub>EE</sub> (Min.) to V<sub>EE</sub> (Max.); V<sub>CC</sub> = V<sub>CCO</sub> = GND

Symbol	Parameter	T <sub>A</sub> = 0°C			T <sub>A</sub> = +25°C			T <sub>A</sub> = +85°C			Unit	Condition
		Min.	Typ.	Max.	Min.	Typ.	Max.	Min.	Typ.	Max.		
V <sub>BB</sub>	Output Reference Voltage										V	—
	10E	-1.38	—	-1.27	-1.35	—	-1.25	-1.31	—	-1.19		
	100E	-1.38	—	-1.26	-1.38	—	-1.26	-1.38	—	-1.26		
I <sub>IH</sub>	Input HIGH Current	—	—	150	—	—	150	—	—	150	μA	—
I <sub>EE</sub>	Power Supply Current										mA	—
	10E	—	92	110	—	92	110	—	92	110		
	100E	—	92	110	—	92	110	—	106	127		
V <sub>PP</sub> (DC)	Input Sensitivity	50	—	—	50	—	—	50	—	—	mV	1
V <sub>CMR</sub>	Common Mode Range	-1.5	—	0	-1.5	—	0	-1.5	—	0	V	2

**NOTES:**

- Differential input voltage required to obtain a full ECL swing on the outputs.
- V<sub>CMR</sub> is referenced to the most positive side of the differential input signal. Normal operation is obtained when the input signals are within the V<sub>CMR</sub> range and the input swing is greater than V<sub>PP</sub> (min.) and <1V.

**AC ELECTRICAL CHARACTERISTICS**V<sub>EE</sub> = V<sub>EE</sub> (Min.) to V<sub>EE</sub> (Max.); V<sub>CC</sub> = V<sub>CCO</sub> = GND

Symbol	Parameter	T <sub>A</sub> = 0°C			T <sub>A</sub> = +25°C			T <sub>A</sub> = +85°C			Unit	Condition		
		Min.	Typ.	Max.	Min.	Typ.	Max.	Min.	Typ.	Max.				
t <sub>PLH</sub> t <sub>PHL</sub>	Propagation Delay to Output D (Diff) D SEL COMSEL	375 325 350 375	475 475 500 525	650 700 725 750	375 325 350 375	475 475 500 525	650 700 725 750	375 325 350 375	475 475 500 525	650 700 725 750	ps	—		
t <sub>skew</sub>	Within-Device Skew	—	40	—	—	40	—	—	40	—			ps	1
t <sub>skew</sub>	Duty Cycle Skew t <sub>PLH</sub> –t <sub>PHL</sub>	—	±10	—	—	±10	—	—	±10	—			ps	2
V <sub>PP</sub> (AC)	Minimum Input Swing	150	—	—	150	—	—	150	—	—			mV	3
t <sub>r</sub> t <sub>f</sub>	Rise/Fall Time 20–80%	150	275	450	150	275	450	150	275	450	ps	—		

**NOTES:**

- Within-device skew is defined as identical transitions on similar paths through a device.
- Duty cycle skew guarantee holds only for differential operation when the delays are measured from the cross point of the inputs to the cross point of the outputs.
- Minimum input swing for which AC parameters are guaranteed.

**PRODUCT ORDERING CODE**

Ordering Code	Package Type	Operating Range
SY10E457JC	J28-1	Commercial
SY10E457JCTR	J28-1	Commercial
SY100E457JC	J28-1	Commercial
SY100E457JCTR	J28-1	Commercial

**28 LEAD PLCC (J28-1)**

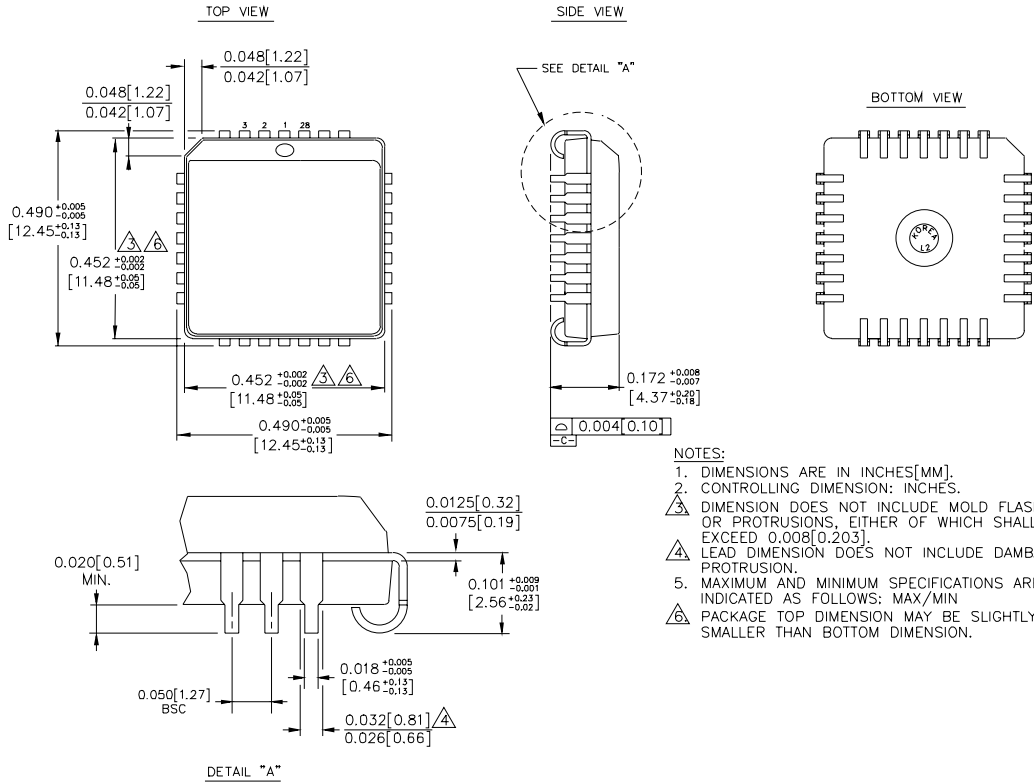

- NOTES:
1. DIMENSIONS ARE IN INCHES[MM].
  2. CONTROLLING DIMENSION: INCHES.
  3. DIMENSION DOES NOT INCLUDE MOLD FLASH OR PROTRUSIONS, EITHER OF WHICH SHALL NOT EXCEED 0.008[0.203].
  4. LEAD DIMENSION DOES NOT INCLUDE DAMBAR PROTRUSION.
  5. MAXIMUM AND MINIMUM SPECIFICATIONS ARE INDICATED AS FOLLOWS: MAX/MIN
  6. PACKAGE TOP DIMENSION MAY BE SLIGHTLY SMALLER THAN BOTTOM DIMENSION.

---

**MICREL-SYNERGY 3250 SCOTT BOULEVARD SANTA CLARA CA 95054 USA**

TEL + 1 (408) 980-9191 FAX + 1 (408) 914-7878 WEB <http://www.micrel.com>

This information is believed to be accurate and reliable, however no responsibility is assumed by Micrel for its use nor for any infringement of patents or other rights of third parties resulting from its use. No license is granted by implication or otherwise under any patent or patent right of Micrel Inc.

© 2000 Micrel Incorporated