

Designer's™ Data Sheet

SWITCHMODE Series

NPN Silicon Power Transistors

These transistors are designed for high-voltage, high-speed switching of inductive circuits where fall time and RBSOA are critical. They are particularly well-suited for line-operated switchmode applications.

The MJE16004 is a high-gain version of the MJE16002 and MJH16002 for applications where drive current is limited.

Typical Applications:

- Switching Regulators
- High Resolution Deflection Circuits
- Inverters
- Motor Drives
- Fast Switching Speeds
 - 50 ns Inductive Fall Time @ 75°C (Typ)
 - 70 ns Crossover Time @ 75°C (Typ)
- 100°C Performance Specified for:
 - Reverse-Biased SOA
 - Inductive Switching Times
 - Saturation Voltages
 - Leakage Currents

MJE16002*
MJE16004*

*Motorola Preferred Device

5.0 AMPERE
NPN SILICON
POWER TRANSISTORS
450 VOLTS
80 WATTS

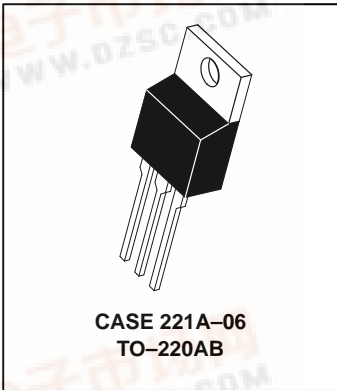

MAXIMUM RATINGS

Rating	Symbol	Value	Unit
Collector-Emitter Voltage	$V_{CEO(sus)}$	450	Vdc
Collector-Emitter Voltage	V_{CEV}	850	Vdc
Emitter-Base Voltage	V_{EB}	6.0	Vdc
Collector Current — Continuous	I_C	5.0	Adc
— Peak (1)	I_{CM}	10	
Base Current — Continuous	I_B	4.0	Adc
— Peak (1)	I_{BM}	8.0	
Total Power Dissipation @ $T_C = 25^\circ\text{C}$	P_D	80	Watts
@ $T_C = 100^\circ\text{C}$		32	
Derate above $T_C = 25^\circ\text{C}$		0.64	W/°C
Operating and Storage Junction Temperature Range	T_J, T_{stg}	-65 to +150	°C

THERMAL CHARACTERISTICS

Characteristic	Symbol	Max	Unit
Thermal Resistance, Junction to Case	$R_{\theta JC}$	1.56	°C/W
Lead Temperature for Soldering Purposes: 1/8" from Case for 5 Seconds	T_L	275	°C

(1) Pulse Test: Pulse Width = 5 ms, Duty Cycle ≤ 10%.

Designer's Data for "Worst Case" Conditions — The Designer's Data Sheet permits the design of most circuits entirely from the information presented. SOA Limit curves — representing boundaries on device characteristics — are given to facilitate "worst case" design.

Preferred devices are Motorola recommended choices for future use and best overall value.

Designer's and SWITCHMODE are trademarks of Motorola, Inc.



MJE16002 MJE16004

ELECTRICAL CHARACTERISTICS (T_C = 25°C unless otherwise noted)

Characteristic	Symbol	Min	Typ	Max	Unit
----------------	--------	-----	-----	-----	------

OFF CHARACTERISTICS (1)

Collector–Emitter Sustaining Voltage (Table 2) (I _C = 100 mA, I _B = 0)	V _{CEO(sus)}	450	—	—	Vdc
Collector Cutoff Current (V _{CEV} = 850 Vdc, V _{BE(off)} = 1.5 Vdc) (V _{CEV} = 850 Vdc, V _{BE(off)} = 1.5 Vdc, T _C = 100°C)	I _{CEV}	—	—	0.25 1.5	mAdc
Collector Cutoff Current (V _{CE} = 850 Vdc, R _{BE} = 50 Ω, T _C = 100°C)	I _{CER}	—	—	2.5	mAdc
Emitter Cutoff Current (V _{EB} = 6.0 Vdc, I _C = 0)	I _{EBO}	—	—	1.0	mAdc

SECOND BREAKDOWN

Second Breakdown Collector Current with Base Forward Biased	I _{S/b}	See Figure 17 or 18			
Clamped Inductive SOA with Base Reverse Biased	RBSOA	See Figure 19			

ON CHARACTERISTICS (1)

Collector–Emitter Saturation Voltage (I _C = 1.5 Adc, I _B = 0.2 Adc) (I _C = 1.5 Adc, I _B = 0.15 Adc) (I _C = 3.0 Adc, I _B = 0.4 Adc) (I _C = 3.0 Adc, I _B = 0.3 Adc) (I _C = 3.0 Adc, I _B = 0.4 Adc, T _C = 100°C) (I _C = 3.0 Adc, I _B = 0.3 Adc, T _C = 100°C)	MJE16002 MJE16004 MJE16002 MJE16004 MJE16002 MJE16004	V _{CE(sat)}	— — — — — —	— — — — — —	1.0 1.0 2.5 2.5 2.5 2.5	Vdc
Base–Emitter Saturation Voltage (I _C = 3.0 Adc, I _B = 0.4 Adc) (I _C = 3.0 Adc, I _B = 0.3 Adc) (I _C = 3.0 Adc, I _S = 0.4 Adc, T _C = 100°C) (I _C = 3.0 Adc, I _B = 0.3 Adc, T _C = 100°C)	MJE16002 MJE16004 MJE16002 MJE16004	V _{BE(sat)}	— — — —	— — — —	1.5 1.5 1.5 1.5	Vdc
DC Current Gain (I _C = 5.0 Adc, V _{CE} = 5.0 Vdc)	MJE16002 MJE16004	h _{FE}	5.0 7.0	— —	— —	—

DYNAMIC CHARACTERISTICS

Output Capacitance (V _{CB} = 10 Vdc, I _E = 0, f _{test} = 1.0 kHz)	C _{ob}	—	—	200	pF
---	-----------------	---	---	-----	----

SWITCHING CHARACTERISTICS

Resistive Load (Table 1)		MJE16002/MJH10002					
Delay Time	(I _C = 3.0 Adc, V _{CC} = 250 Vdc, I _{B1} = 0.4 Adc, PW = 30 μs, Duty Cycle ≤ 2.0%)	(I _{B2} = 0.8 Adc, R _{B2} = 8.0 Ω)	t _d	—	30	100	ns
Rise Time			t _r	—	100	300	
Storage Time			t _s	—	1000	3000	
Fall Time			t _f	—	60	300	
Storage Time		(V _{BE(off)} = 5.0 Vdc)	t _s	—	400	—	
Fall Time			t _f	—	130	—	
Resistive Load (Table 1)		MJE16004/MJH16004					
Delay Time	(I _C = 3.0 Adc, V _{CC} = 250 Vdc, I _{B1} = 0.3 Adc, PW = 30 μs, Duty Cycle ≤ 2.0%)	(I _{B2} = 0.6 Adc, R _{B2} = 8.0 Ω)	t _d	—	30	100	ns
Rise Time			t _r	—	130	300	
Storage Time			t _s	—	800	2700	
Fall Time			t _f	—	80	350	
Storage Time		(V _{BE(off)} = 5.0 Vdc)	t _s	—	250	—	
Fall Time			t _f	—	60	—	

(1) Pulse Test: PW = 300 μs, Duty Cycle ≤ 2%.

$$*\beta_f = \frac{I_C}{I_{B1}}$$

SWITCHING CHARACTERISTICS (continued)

Characteristics		Symbol	Min	Typ	Max	Unit	
Inductive Load (Table 2) MJE16002							
Storage Time	$I_C = 3.0 \text{ Adc}$, $I_{B1} = 0.4 \text{ Adc}$, $V_{BE(\text{off})} = 5.0 \text{ Vdc}$, $V_{CE(\text{pk})} = 400 \text{ Vdc}$	$(T_J = 100^\circ\text{C})$	t_{sv}	—	500	1600	ns
Fall Time			t_{fi}	—	100	200	
Crossover Time			t_c	—	120	250	
Storage Time		$(T_J = 150^\circ\text{C})$	t_{sv}	—	600	—	
Fall Time			t_{fi}	—	120	—	
Crossover Time			t_c	—	160	—	
Inductive Load (Table 2) MJE16004							
Storage Time	$I_C = 3.0 \text{ Adc}$, $I_{B1} = 0.3 \text{ Adc}$, $V_{BE(\text{off})} = 5.0 \text{ Vdc}$, $V_{CE(\text{pk})} = 400 \text{ Vdc}$	$(T_J = 100^\circ\text{C})$	t_{sv}	—	400	1300	ns
Fall Time			t_{fi}	—	80	150	
Crossover Time			t_c	—	90	200	
Storage Time		$(T_J = 150^\circ\text{C})$	t_{sv}	—	450	—	
Fall Time			t_{fi}	—	100	—	
Crossover Time			t_c	—	110	—	

(1) Pulse Test: PW = 300 μs , Duty Cycle $\leq 2\%$.

$$*\beta_f = \frac{I_C}{I_{B1}}$$

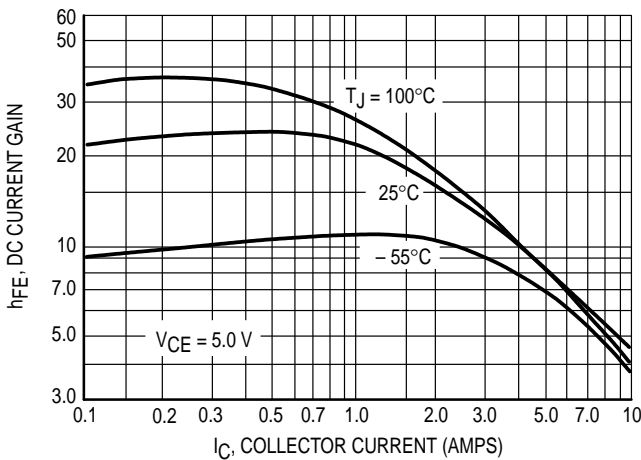

Figure 1. DC Current Gain

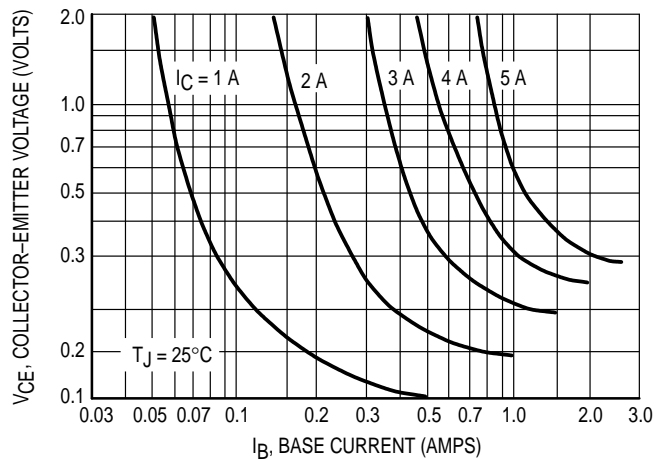

Figure 2. Collector Saturation Region

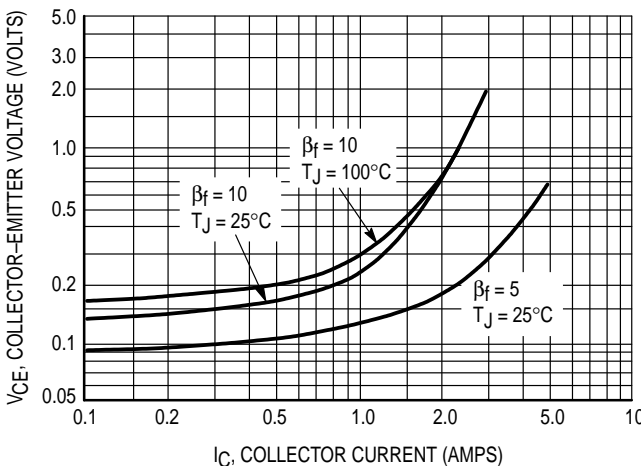

Figure 3. Collector-Emitter Saturation Region

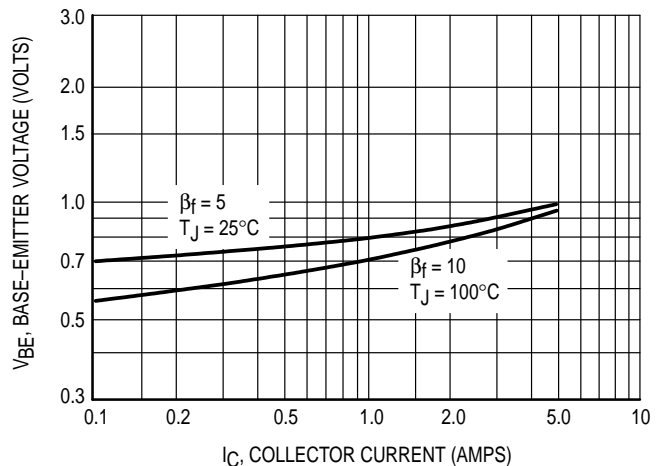

Figure 4. Base-Emitter Voltage

MJE16002 MJE16004

TYPICAL STATIC CHARACTERISTICS (continued)

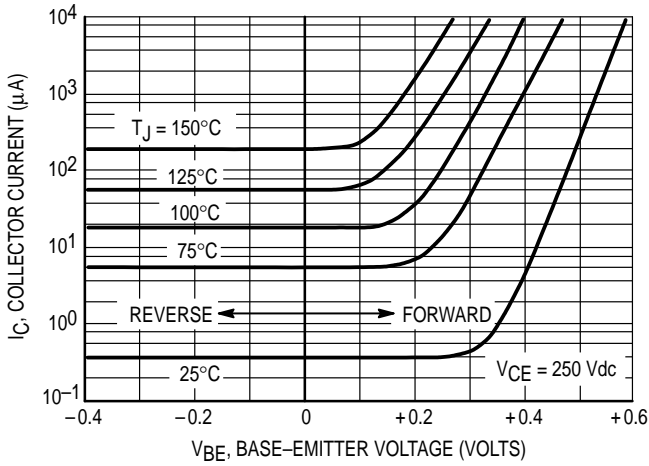

Figure 5. Collector Cutoff Region

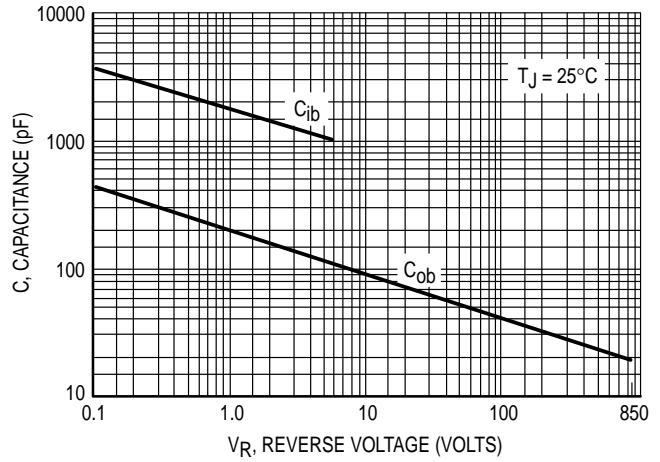

Figure 6. Capacitance

TYPICAL DYNAMIC CHARACTERISTICS

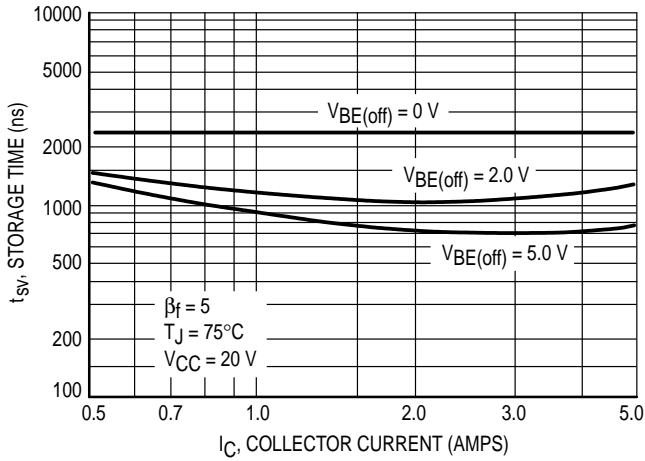

Figure 7. Storage Time

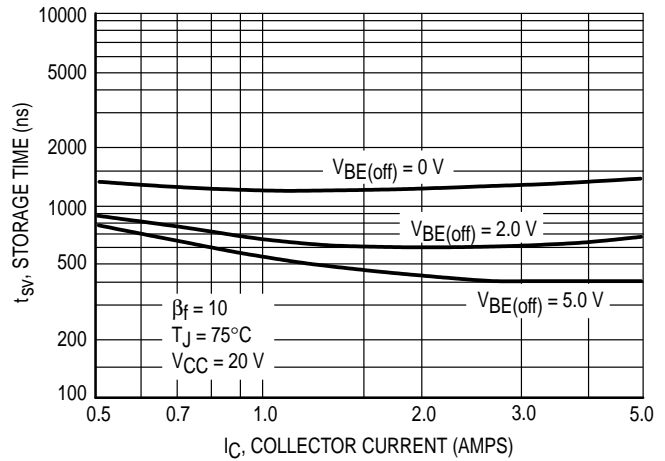

Figure 8. Storage Time

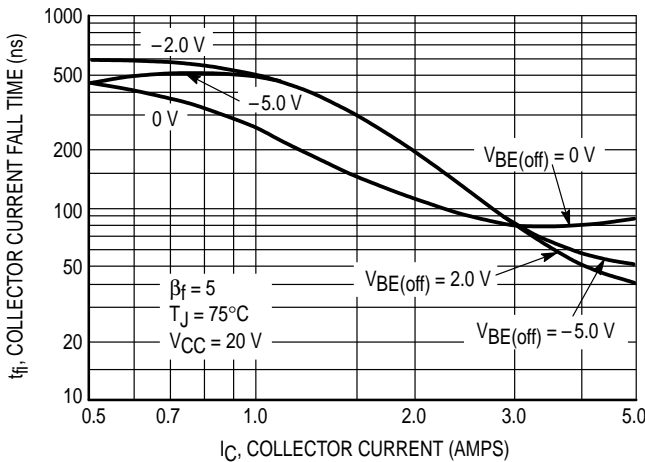

Figure 9. Collector Current Fall Time

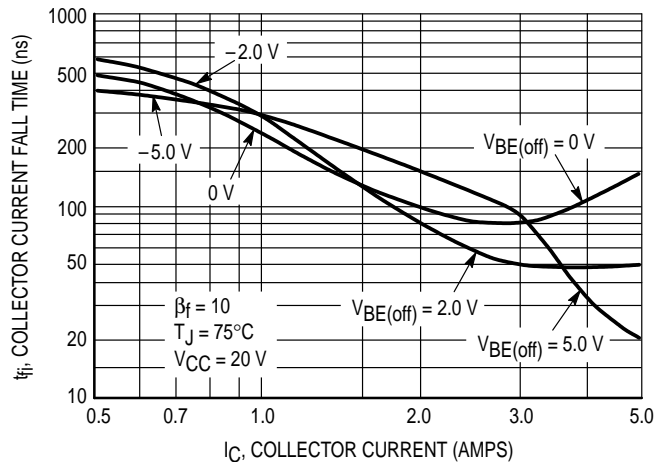

Figure 10. Collector Current Fall Time

TYPICAL DYNAMIC CHARACTERISTICS (continued)

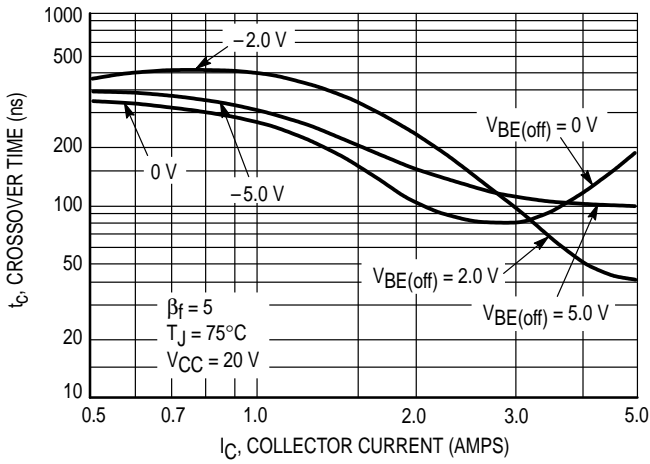

Figure 11. Crossover Time

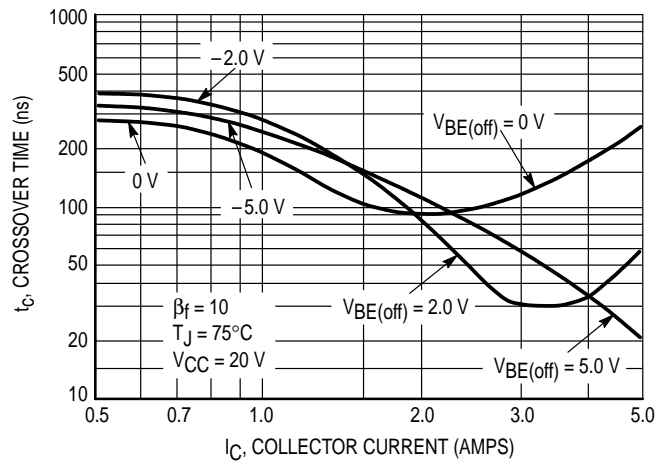

Figure 12. Crossover Time

TYPICAL ELECTRICAL CHARACTERISTICS

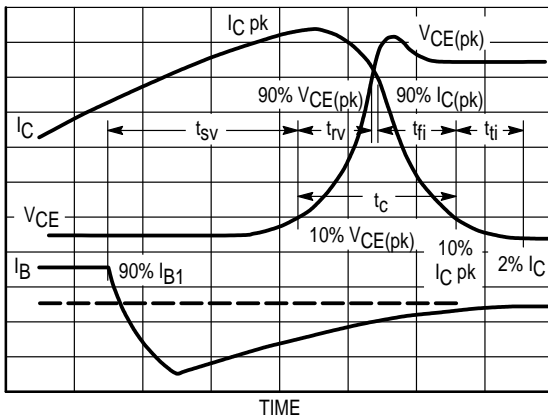

Figure 13. Inductive Switching Measurements

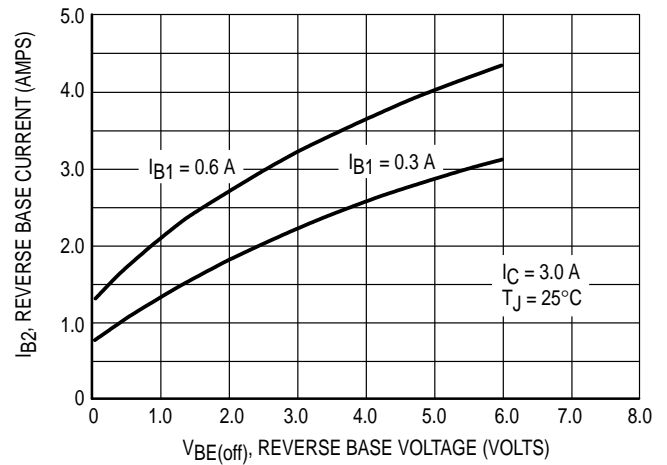

Figure 14. Peak Reverse Base Current

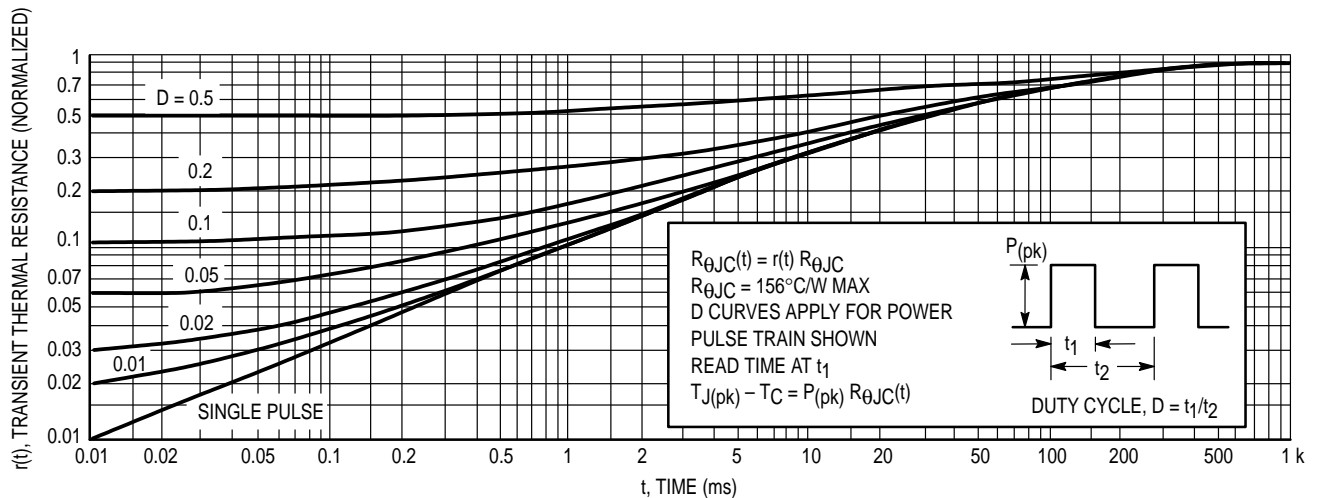

Figure 15. Thermal Response (MJE16002 and MJE16004)

MJE16002 MJE16004

SAFE OPERATING AREA INFORMATION

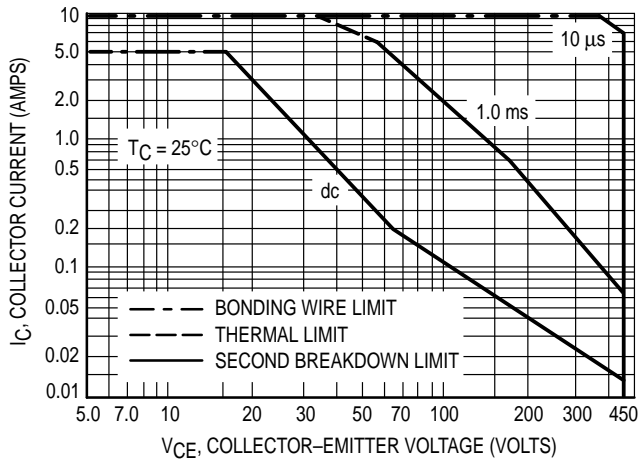

Figure 16. Maximum Rated Forward Bias Safe Operating Area (MJE16002 and MJE16004)

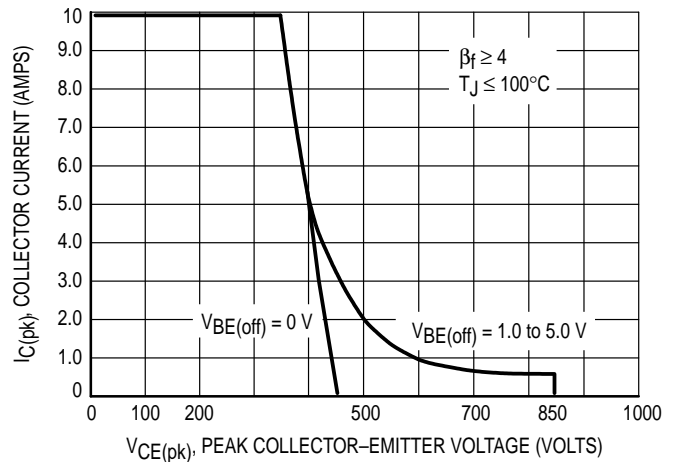

Figure 17. Maximum Rated Reverse Bias Safe Operating Area

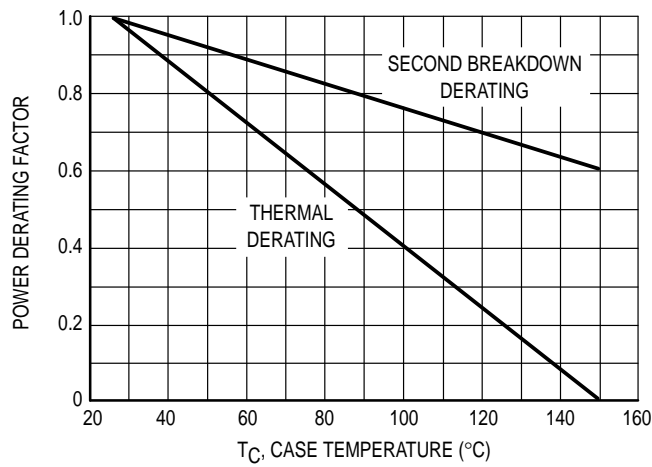

Figure 18. Power Derating

SAFE OPERATING AREA INFORMATION

FORWARD BIAS

There are two limitations on the power handling ability of a transistor: average junction temperature and second breakdown. Safe operating area curves indicate $I_C - V_{CE}$ limits of the transistor that must be observed for reliable operation; i.e., the transistor must not be subjected to greater dissipation than the curves indicate.

The data of Figure 16 is based on $T_C = 25^\circ\text{C}$; $T_{J(pk)}$ is variable depending on power level. Second breakdown pulse limits are valid for duty cycles to 10% but must be derated when $T_C \geq 25^\circ\text{C}$. Second breakdown limitations do not derate the same as thermal limitations. Allowable current at the voltages shown on Figures 17 and 18 may be found at any case temperature by using the appropriate curve on Figure 20.

$T_{J(pk)}$ may be calculated from the data in Figure 15. At high case temperatures, thermal limitations will reduce the

power that can be handled to values less than the limitations imposed by second breakdown.

REVERSE BIAS

For inductive loads, high voltage and high current must be sustained simultaneously during turn-off, in most cases, with the base-to-emitter junction reverse biased. Under these conditions the collector voltage must be held to a safe level at or below a specific value of collector current. This can be accomplished by several means such as active clamping, RC snubbing, load line shaping, etc. The safe level for these devices is specified as Reverse Bias Safe Operating Area and represents the voltage-current condition allowable pulling reverse biased turn-off. This rating is verified under clamped conditions so that the device is never subjected to an avalanche mode. Figure 17 gives the RBSOA characteristics.

Table 1. Resistive Load Switching

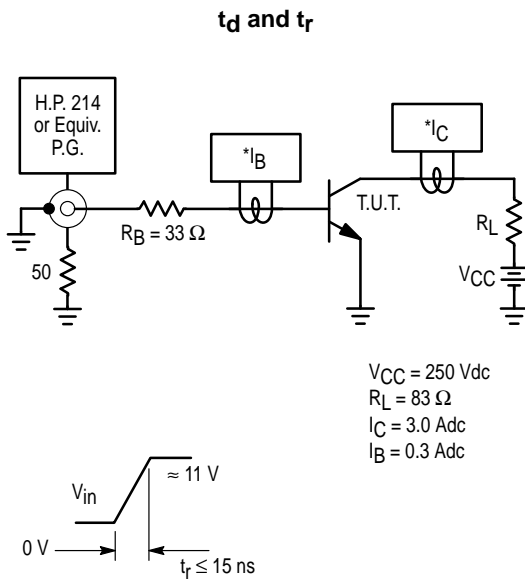

*Tektronix P-6042 or Equivalent

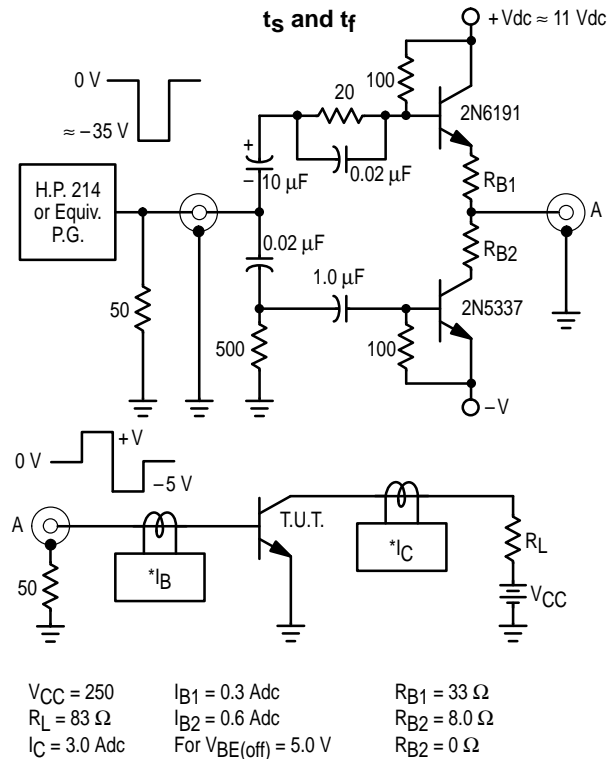

Note: Adjust -V to obtain desired $V_{BE(off)}$ at Point A.

MJE16002 MJE16004

Table 2. Inductive Load Switching

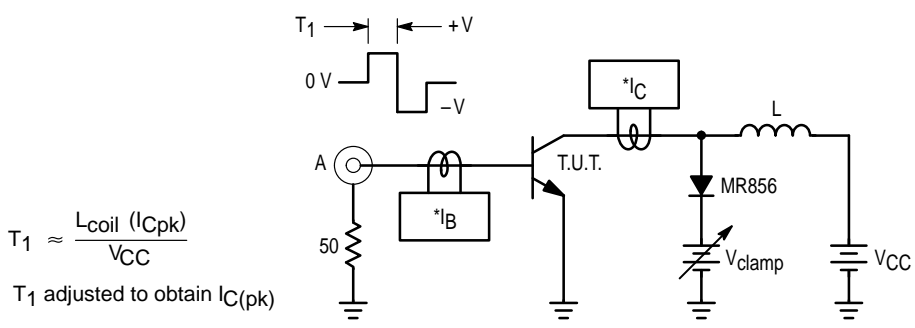
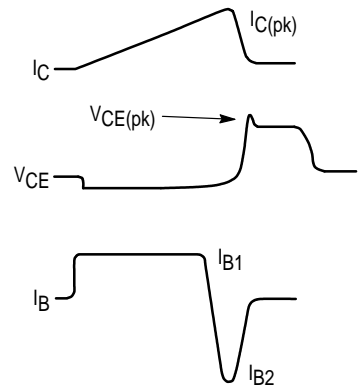
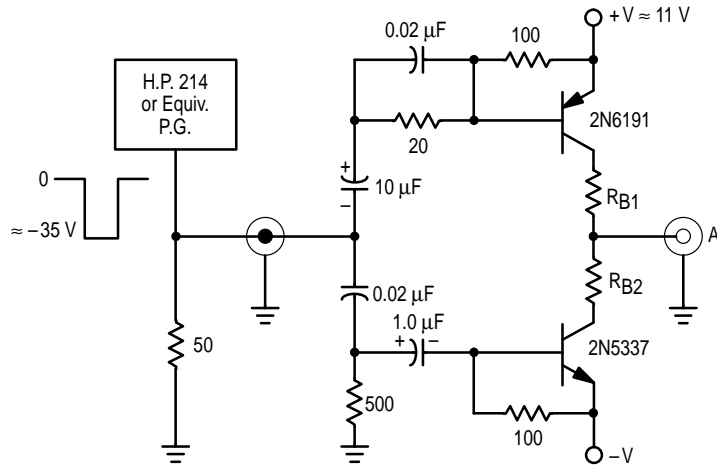

$$T_1 \approx \frac{L_{coil} (I_{Cpk})}{V_{CC}}$$

T₁ adjusted to obtain I_{C(pk)}

V_{CEO(sus)}
 L = 10 mH
 R_{B2} = ∞
 V_{CC} = 20 Volts

Inductive Switching
 L = 200 μH
 R_{B2} = 0
 V_{CC} = 20 Volts
 R_{B1} selected for desired I_{B1}

RBSOA
 L = 200 μH
 R_{B2} = 0
 V_{CC} = 20 Volts
 R_{B1} selected for desired I_{B1}

*Tektronix
 P-6042 or
 Equivalent

Scope — Tektronix
 7403 or
 Equivalent

Note: Adjust -V to obtain desired V_{BE(off)} at Point A.

TYPICAL INDUCTIVE SWITCHING WAVEFORMS

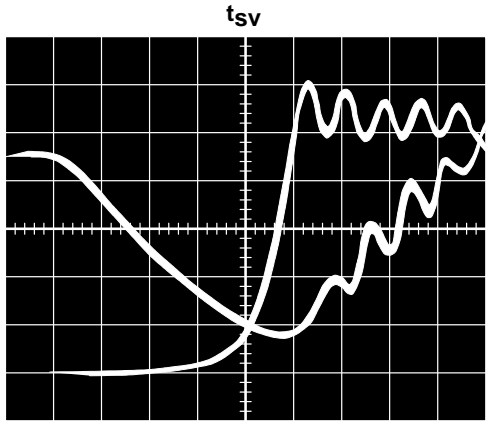

I_{C(pk)} = 3.0 Amps
 I_{B1} = 0.3 Amp
 V_{BE(off)} = 5.0 Volts
 V_{CE(pk)} = 300 Volts
 T_C = 25°C
 Time Base =
 20 ns/cm

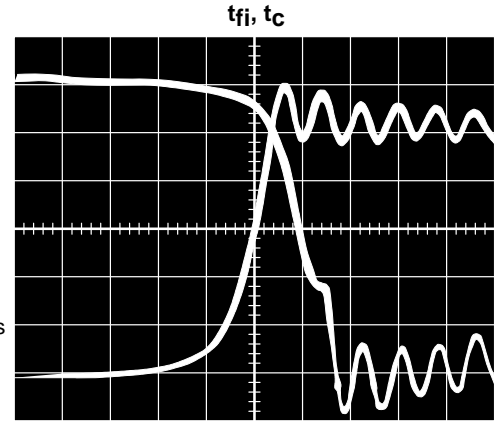

I_{C(pk)} = 3.0 Amps
 I_{B1} = 0.3 Amp
 V_{BE(off)} = 5.0 Volts
 V_{CE(pk)} = 300 Volts
 T_C = 25°C
 Time Base =
 20 ns/cm

PACKAGE DIMENSIONS

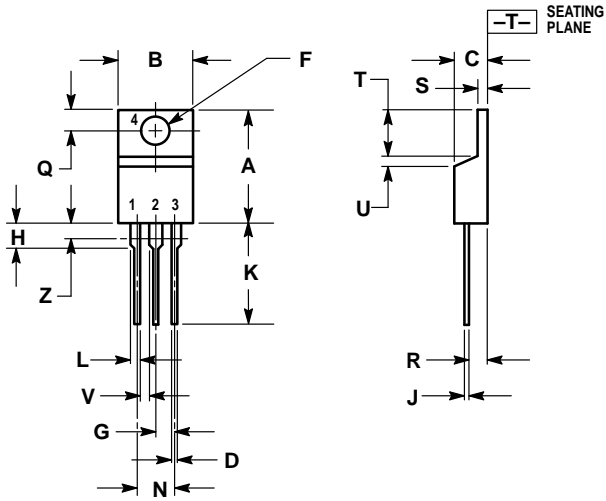

- NOTES:
1. DIMENSIONING AND TOLERANCING PER ANSI Y14.5M, 1982.
 2. CONTROLLING DIMENSION: INCH.
 3. DIMENSION Z DEFINES A ZONE WHERE ALL BODY AND LEAD IRREGULARITIES ARE ALLOWED.

DIM	INCHES		MILLIMETERS	
	MIN	MAX	MIN	MAX
A	0.570	0.620	14.48	15.75
B	0.380	0.405	9.66	10.28
C	0.160	0.190	4.07	4.82
D	0.025	0.035	0.64	0.88
F	0.142	0.147	3.61	3.73
G	0.095	0.105	2.42	2.66
H	0.110	0.155	2.80	3.93
J	0.018	0.025	0.46	0.64
K	0.500	0.562	12.70	14.27
L	0.045	0.060	1.15	1.52
N	0.190	0.210	4.83	5.33
Q	0.100	0.120	2.54	3.04
R	0.080	0.110	2.04	2.79
S	0.045	0.055	1.15	1.39
T	0.235	0.255	5.97	6.47
U	0.000	0.050	0.00	1.27
V	0.045	—	1.15	—
Z	—	0.080	—	2.04

- STYLE 1:
 PIN 1. BASE
 2. COLLECTOR
 3. EMITTER
 4. COLLECTOR

CASE 221A-06
 TO-220AB
 ISSUE Y

MJE16002 MJE16004

Motorola reserves the right to make changes without further notice to any products herein. Motorola makes no warranty, representation or guarantee regarding the suitability of its products for any particular purpose, nor does Motorola assume any liability arising out of the application or use of any product or circuit, and specifically disclaims any and all liability, including without limitation consequential or incidental damages. "Typical" parameters can and do vary in different applications. All operating parameters, including "Typicals" must be validated for each customer application by customer's technical experts. Motorola does not convey any license under its patent rights nor the rights of others. Motorola products are not designed, intended, or authorized for use as components in systems intended for surgical implant into the body, or other applications intended to support or sustain life, or for any other application in which the failure of the Motorola product could create a situation where personal injury or death may occur. Should Buyer purchase or use Motorola products for any such unintended or unauthorized application, Buyer shall indemnify and hold Motorola and its officers, employees, subsidiaries, affiliates, and distributors harmless against all claims, costs, damages, and expenses, and reasonable attorney fees arising out of, directly or indirectly, any claim of personal injury or death associated with such unintended or unauthorized use, even if such claim alleges that Motorola was negligent regarding the design or manufacture of the part. Motorola and  are registered trademarks of Motorola, Inc. Motorola, Inc. is an Equal Opportunity/Affirmative Action Employer.

How to reach us:

USA / EUROPE: Motorola Literature Distribution;
P.O. Box 20912; Phoenix, Arizona 85036. 1-800-441-2447

MFAX: RMFAX0@email.sps.mot.com – TOUCHTONE (602) 244-6609
INTERNET: <http://Design-NET.com>

JAPAN: Nippon Motorola Ltd.; Tatsumi-SPD-JLDC, Toshikatsu Otsuki,
6F Seibu-Butsuryu-Center, 3-14-2 Tatsumi Koto-Ku, Tokyo 135, Japan. 03-3521-8315

HONG KONG: Motorola Semiconductors H.K. Ltd.; 8B Tai Ping Industrial Park,
51 Ting Kok Road, Tai Po, N.T., Hong Kong. 852-26629298

