



JOSEPH

AC/DC Single/Multirange CHARGER

Tentative data

FEATURES

- LINE VOLTAGE 230 VAC. ALSO AVAILABLE THE MULTIRANGE VERSION 90-264VAC
- SINGLE OUTPUT MAX 4W
- DESIGNED FOR ON LINE CHARGING OF MOBILE PHONES
- EMC COMPLIANCE ACCORDING TO EU AND US DIRECTIVES
- SAFETY APPROVAL ACCORDING TO EN60950
- CE AND UL MARKED. AUSTRALIA, UK, SOUTH AFRICA AND CHINA MARKING UPON REQUEST
- OUTPUT CURRENT AND VOLTAGE LEVELS ACCORDING TO CUSTOMER REQUIREMENTS
- OUTPUT VOLTAGE PRECISION: +/- 10%
- OUTPUT CURRENT PRECISION : +/- 20%
- OUTPUT RIPPLE VOLTAGE <100 mVpp
- INPUT FUSE PROTECTION
- OUTPUT SHORT CIRCUIT PROTECTION
- 2 WIRES DC CORD TERMINATED WITH ANY CUSTOM CONNECTOR
- AVAILABLE WITH A VARIETY OF AC PLUGS
- LOW STAND BY POWER

PRODUCT VIEW



(Robin Housing, all plug types)

ORDERING NUMBER: GSAC-xxCCCy

Plug Type:	Part Number:
EURO	GSAC-xxCCC1
UK	GSAC-xxCCC2
US	GSAC-xxCCC3
AUSTRALIA	GSAC-xxCCC4
INDIA/S. Africa	GSAC-xxCCC5
CHINA	GSAC-xxCCC6

xx = Output Current level (2 Digits)
 CCC= Customer Identifier (3 Digits)
 y = plug type

DESCRIPTION

The Charger JOSEPH has been designed for charging NiMH and NiCd batteries in hand held mobile phones. JOSEPH is a very low cost high efficiency AC/DC switching mode constant voltage & current generator. The output voltage and current levels are set up by design in accordance with customer requirements.

JOSEPH

Typical reference values in this data sheet are 8V, 500 mA with the input 230 Vac. The multi-range version (90 to 264 Vrms) is also available upon customer request.

Coming into the small Robin housing, JOSEPH can be assembled with a variety of AC plugs identified by specific ordering numbers. Interface to the phone is ensured via a 2 wires cord with strain relief, terminated with customer specified connector. Typical weight is 70 grams only, without cable.

AGENCY Approvals

The charger is certified by competent agencies to comply with most popular safety and EMC requirements, including but not limited to:

EN60950
UL1950
ETS300-342-1

ELECTRICAL CHARACTERISTICS (T_{amb}=25°C, unless otherwise specified.)

Symbol	Parameter	Test Condition	Min.	Typ.	Max.	Unit
V _i	Input Voltage		90	230	264	Vrms
V _o	Output Voltage limit	No load	7.2	8.0	8.8	V
I _o	Output Current limit	3<V _{out} <V _o limit	400	500	600	mA
V _{or}	Output Ripple	I _o =I _{limit} V _{batt} =4V			100	mVpp
V _{is}	Isolation voltage	Input to output, t=60s (EN60950)	3000			Vrms
T _{op}	Operating Temperature Ambient		0		50	°C
T _{stg}	Storage Temperature Range		-20		70	°C
n	efficiency			75%		

TYPICAL OUTPUT CHARACTERISTIC

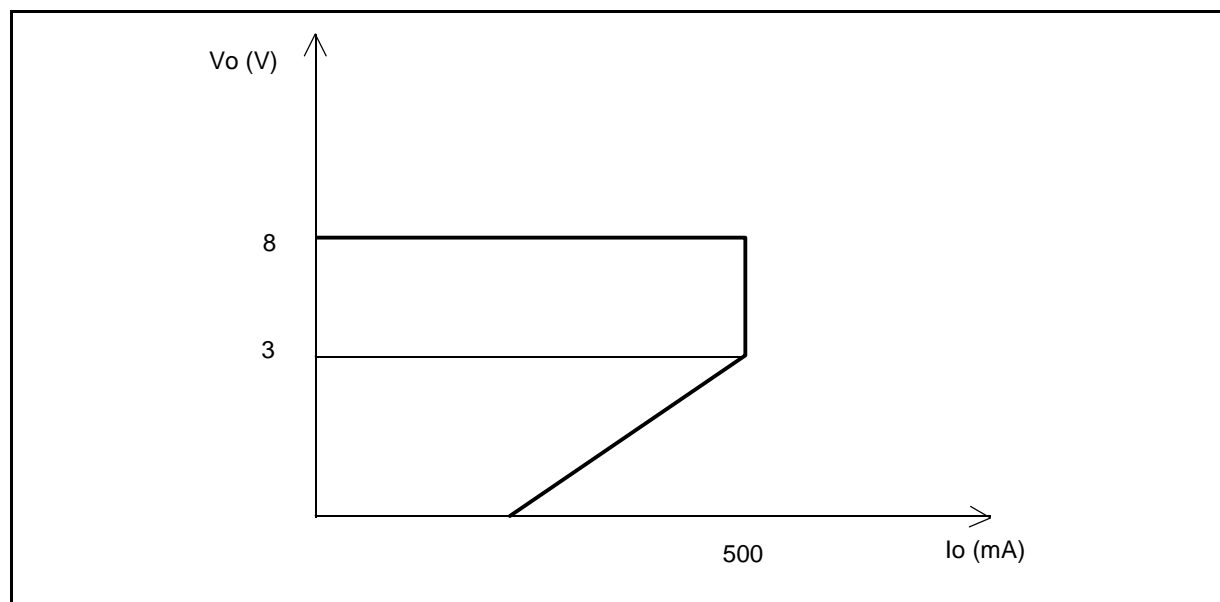

MECHANICAL DATA EURO plug version (dimensions in mm)

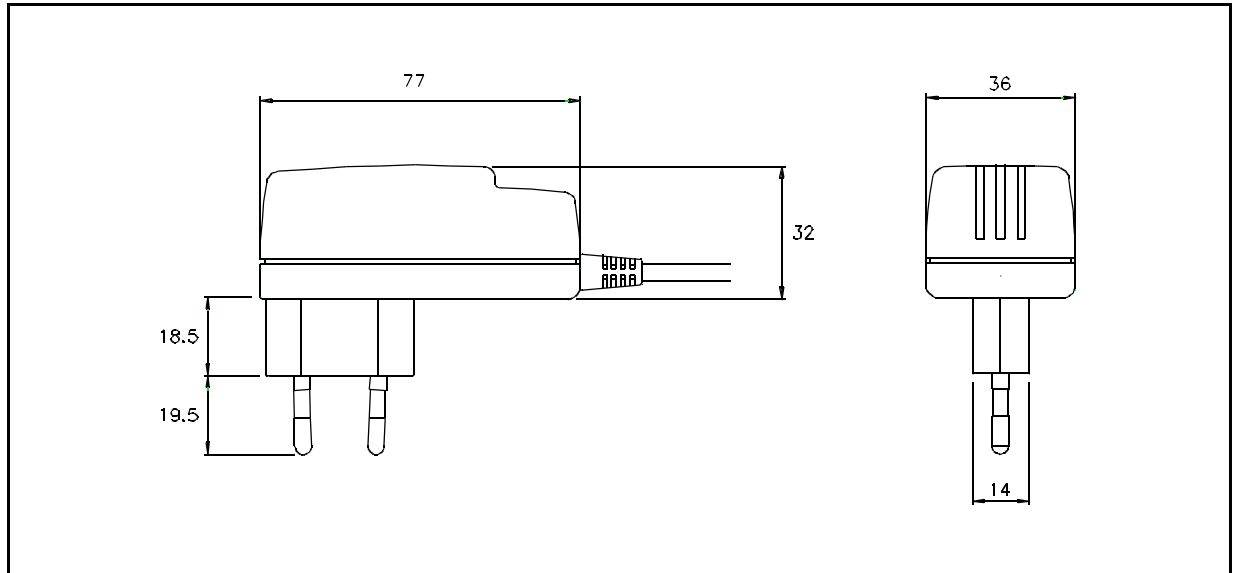

MECHANICAL DATA UK plug version (dimensions in mm)

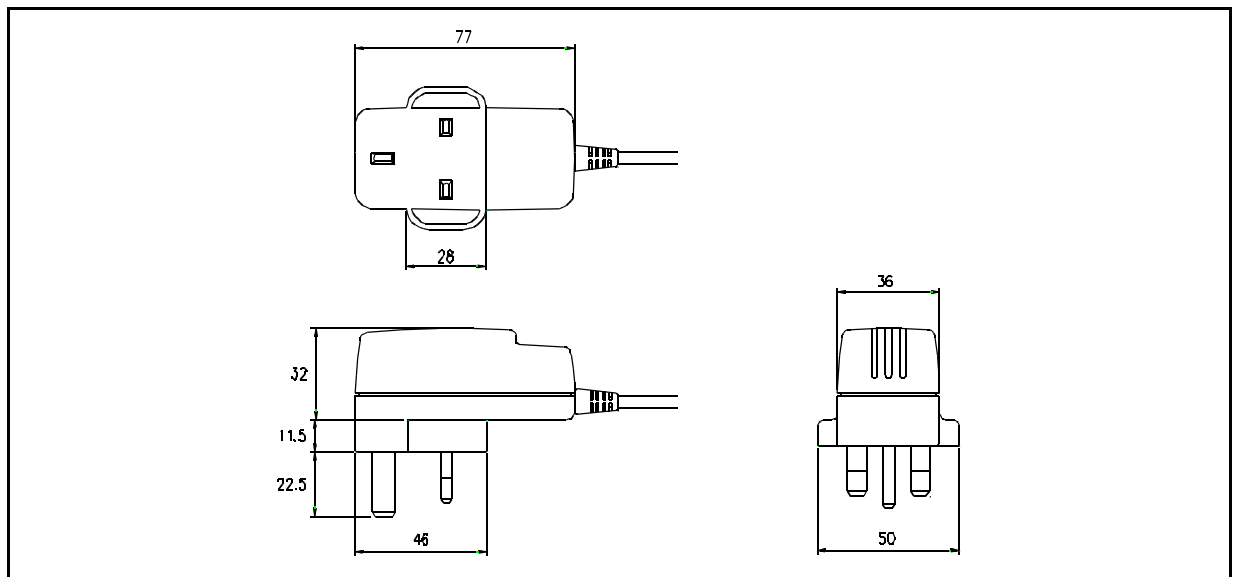

MECHANICAL DATA US plug version (dimensions in mm)

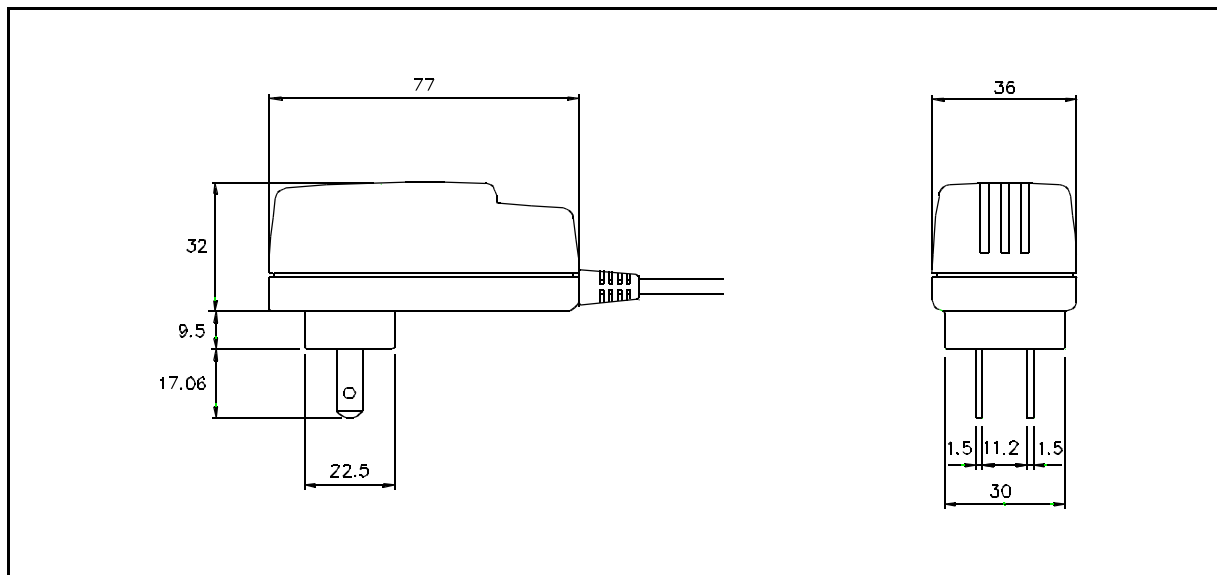

Fast Chargers SELECTION chart

PARAMETER	GHIBLI	MISTRAL	JOSEPH
INPUT VOLTAGE RANGE - Vrms	90 - 264	90 - 264	90 - 264
MAX OUTPUT POWER - Watt	8	8	4
OUTPUT VOLTAGE ACCURACY	+/- 5%	+/- 5%	+/- 10%
OUTPUT CURRENT ACCURACY	+/- 8%	+/- 12%	+/- 20%
OUTPUT VOLTAGE RIPPLE - mVpp	< 100	< 100	< 100
ISOLATION VOLTAGE- Vrms	> 3000	> 3000	> 3000
OPERATING AMBIENT TEMPERATURE - °C	0 - 50	0 - 50	0 - 50
STORAGE TEMPERATURE RANGE - °C	-20 +70	-20 +70	-20 +70
AC INPUT FUSE PROTECTION	YES	YES	YES
DC OUTPUT SHORT CIRCUIT PROTECTION	YES	YES	YES
WEIGHT (without cable) - Grams	70	70	70

Information furnished is believed to be accurate and reliable. However, STMicroelectronics assumes no responsibility for the consequences of use of such information nor for any infringement of patents or other rights of third parties which may result from its use. No license is granted by implication or otherwise under any patent or patent rights of STMicroelectronics. Specification mentioned in this publication are subject to change without notice. This publication supersedes and replaces all information previously supplied. STMicroelectronics products are not authorized for use as critical components in life support devices or systems without express written approval of STMicroelectronics.

The ST logo is a registered trademark of STMicroelectronics
 © 2000 STMicroelectronics – Printed in Italy – All Rights Reserved
 STMicroelectronics GROUP OF COMPANIES

Australia - Brazil - China - Finland - France - Germany - Hong Kong - India - Italy - Japan - Malaysia - Malta - Morocco - Singapore - Spain - Sweden - Switzerland - United Kingdom - U.S.A.

<http://www.st.com>