



16-BIT SERIAL TO PARALLEL CONVERTER

GENERAL DESCRIPTION

The NJU3715 is a 16-bit serial to parallel converter especially apply to MPU outport expander.

The effective outport assignment of MPU is available as the connection between NJU3715 and MPU is required only 4 lines.

Up to 5MHz signal can be input to the serial data input terminal and the data is output from parallel output buffer through serial in parallel out shift register and parallel data latches.

The hysteresis input circuit realized wide noise margin and high drivability output buffer (25mA) can drive LED directly.

PACKAGE OUTLINE

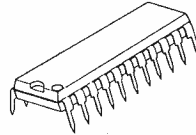

NJU3715L

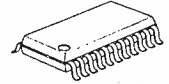

NJU3715G

FEATURES

- 16-Bit Serial In Parallel Out
 - Hysteresis Input
 - Operating Voltage
 - Operating Frequency
 - Output Current
 - C-MOS Technology
 - Package Outline
- 0.5V typ
 --- 5V±10%
 --- 5MHz or more
 --- 25mA
 --- SDIP/SOP 22

PIN CONFIGURATION

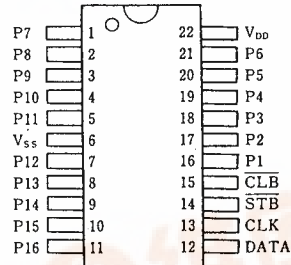

BLOCK DIAGRAM

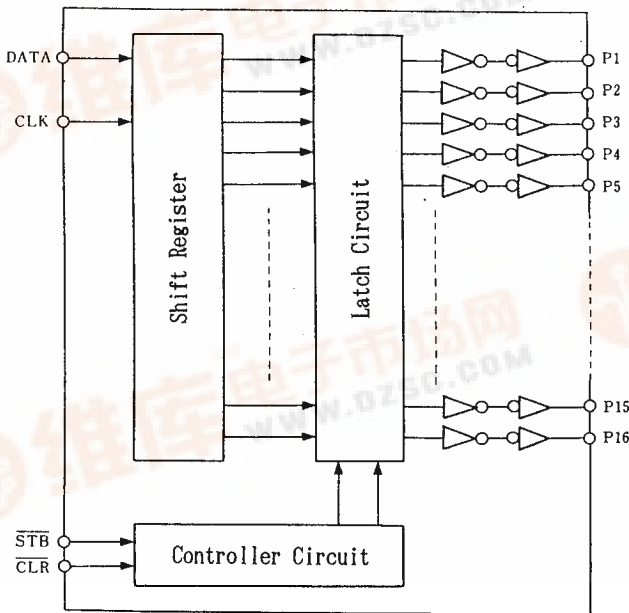

■ TERMINAL DESCRIPTION

NO.	SYMBOL	F U N C T I O N	NO.	SYMBOL	F U N C T I O N
1	P7	Parallel Converts Data Output Terminals	12	DATA	Serial Data Input Terminal
2	P8		13	CLK	Clock Signal Input Terminal
3	P9		14	$\overline{\text{STB}}$	Strove Signal Input Terminal
4	P10		15	$\overline{\text{CLR}}$	Clear Signal Input Terminal
5	P11		16	P1	Parallel Converts Data Output Terminals
6	V _{SS}	GND	17	P2	
7	P12	Parallel Converts Data Output Terminals	18	P3	
8	P13		19	P4	
9	P14		20	P5	
10	P15		21	P6	
11	P16		22	V _{DD}	Power Supply Terminal

7
■ FUNCTIONAL DESCRIPTION
(1) Reset

When the "L" level is input to the $\overline{\text{CLR}}$ terminal, all latches are reset and all parallel conversion output are "L" level.

Normally, the CLR terminal should be "H" level.

(2) Data Transmission

In the $\overline{\text{STB}}$ terminal is "H" level and input the clock signal to the CLK terminal, the serial data input from DATA terminal shift in the shift register by synclonizing at rising edge of the clock signal.

When the $\overline{\text{STB}}$ terminal change to "L" level, the data in the shift register transfer to the latch.

Even if the $\overline{\text{STB}}$ terminal is "L" level, the input clock signal shift the data in the shift register, therefore, the clock signal control is needed.

Furthermore, the 4 input circuits have a hysteresis characteristics by using the schmitt trigger structure to protect the noise.

CLK	$\overline{\text{STB}}$	$\overline{\text{CLR}}$	O P E R A T I O N
X	X	L	All latch are reset (the data in the shift register is no change). All of Parallel convert output are "L".
	H	H	The serial data input from DATA terminal input to the shift register. In this stage, the data in the latch is no change.
L	L	H	The data in the shift register transfer to the latch. And the data in the latch output from parallel output.
H			
			The CLK input in the $\overline{\text{STB}}=\text{"L"}$ and $\overline{\text{CLR}}=\text{"H"}$ state, the data shift in the shift register and latched data also change in accordance with the shift register.

Note) X: Don't care

■ TIMING CHART

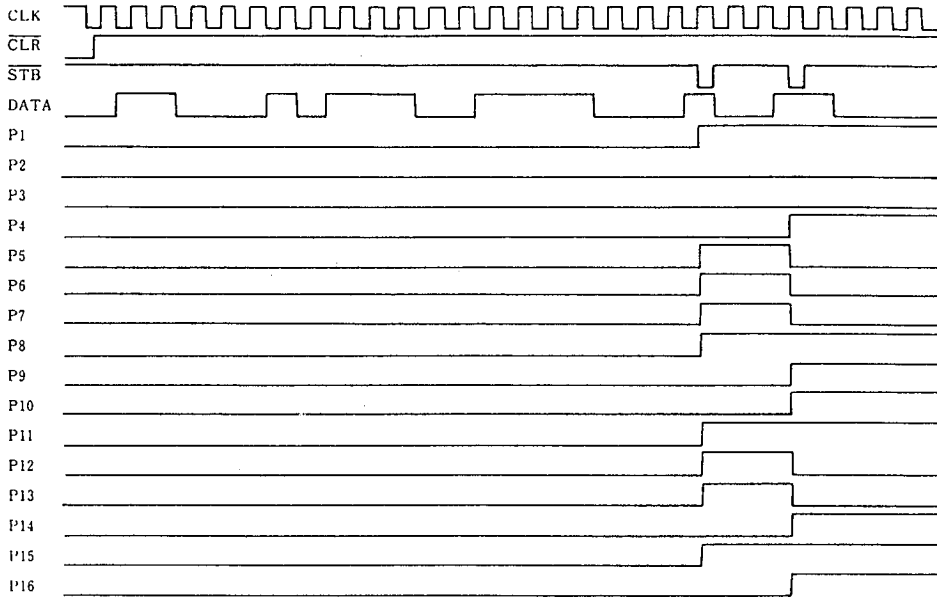

■ ABSOLUTE MAXIMUM RATINGS

(Ta=25°C)

PARAMETER	SYMBOL	RATINGS	UNIT
Supply Voltage Range	V_{DD}	-0.5 ~ 7.0	V
Input Voltage Range	V_i	$V_{SS}-0.5 \sim V_{DD}+0.5$	V
Output Voltage Range	V_o	$V_{SS}-0.5 \sim V_{DD}+0.5$	V
Output Current	I_o	± 25	mA
Power Dissipation	P_D	700 (SDIP) 400 (SOP)	mW
Operating Temperature Range	T_{opr}	-25 ~ +85	°C
Storage Temperature Range	T_{stg}	-65 ~ +150	°C

■ DC ELECTRICAL CHARACTERISTICS

 (V_{DD}=4.5~5.5V, V_{SS}=0V, T_a=25°C)

PARAMETER	SYMBOL	CONDITION	MIN	TYP	MAX	UNIT
Operating Current	I _{DDs}	V _{IH} =V _{DD} , V _{IL} =V _{SS}			0.1	mA
Input Voltage	High-Level	V _{IH}	0.7V _{DD}		V _{DD}	V
	Low-Level	V _{IL}	V _{SS}		0.3V _{DD}	
Input Leakage Current	I _{LI}	V _I =0~V _{DD}	-10		10	μA
High-Level Output Voltage	V _{OHD}	I _{OH} =-25mA	V _{DD} -1.5		V _{DD}	V
		I _{OH} =-15mA	V _{DD} -1.0		V _{DD}	
		I _{OH} =-10mA	V _{DD} -0.5		V _{DD}	
Low-Level Output Voltage	V _{OLD}	I _{OL} =+25mA	V _{SS}		1.5	V
		I _{OL} =+15mA	V _{SS}		0.8	
		I _{OL} =+10mA	V _{SS}		0.4	
Output Short Current	I _{OSD}	V _O =7V, V _I =0V			20	mA
		V _O =0V, V _I =7V			-20	

Note 1) Specified value represent output current per pin. When use, total current consideration and less than power dissipation rating operation should be required.

Note 2) V_{DD}=7V, V_{SS}=0V, 1 second per pin.

■ SWITCHING CHARACTERISTICS

 (V_{DD}=4.5V~5.5V, V_{SS}=0V, T_a=-20~75°C)

PARAMETER	SYMBOL	CONDITION	MIN	TYP	MAX	UNIT
Set-Up Time	t _{SD}	DATA - CLK	20			ns
Hold Time	t _{HD}	CLK - DATA	20			ns
Set-Up Time	t _{SS_{STB}}	STB - CLK	30			ns
Hold Time	t _{H_{STB}}	CLK - STB	30			ns
Output Delay Time	t _{pd PCK}	CLK - P1~P16			100	ns
	t _{pd PSTB}	STB - P1~P16			80	ns
	t _{pd PCLR}	CLR - P1~P16			80	ns
Max. Operating Frequency	f _{MAX}		5			MHz

*) C_{OUT}=50pF

■ SWITCHING CHARACTERISTICS TEST WAVEFORM

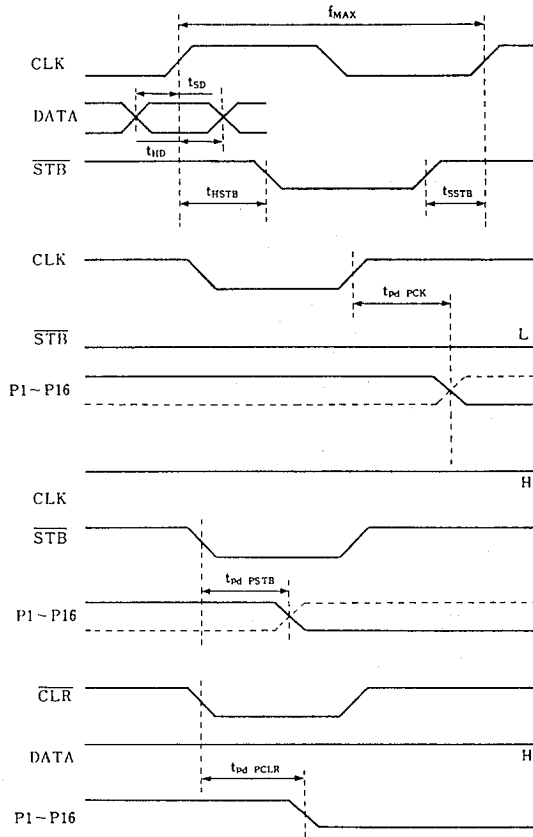

■ APPLICATION CIRCUIT

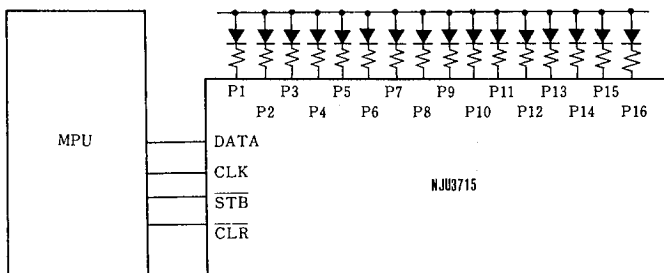

NJU3715

MEMO

[CAUTION]
The specifications on this databook are only given for information, without any guarantee as regards either mistakes or omissions. The application circuits in this databook are described only to show representative usages of the product and not intended for the guarantee or permission of any right including the industrial rights.