

JZX-140FF MINIATURE INTERMEDIATE POWER RELAY

US

File No.:E133481



File No.:R9659298



File No.:CH0023315-2002A



Features

- 10A switching capabilities
- DPST-NO and DPDT configurations
- 5KV dielectric between coil to contacts
- Sealed & Unsealed types available

CONTACT DATA

Contact Arrangement	2A, 2C
Initial Contact Resistance Max.	50mΩ(1A 24VDC)
Contact Material	AgCdO
Contact Rating (Res. Load)	5A 220VAC/30VDC
Max. switching voltage	250VAC/30VDC
Max. switching current	10A
Max. switching power	2500VAC/300W
UL/CUR rating	10A 250VAC/30VDC 8A 30VDC TV-3, 125VAC
TÜV rating	5A 250VAC/30VDC
Mechanical life	1 x 10 ⁷ OPS
Electrical life	1 x 10 ⁶ OPS

COIL

Coil power	0.55W
------------	-------

COIL DATA

Nominal Voltage VDC	Pick-up Voltage VDC	Drop-out Voltage VDC	Max. allowable Voltage VDC(at 20°C)	Coil Resistance Ω
3	2.25	0.3	3.9	17 ± 10%
5	3.75	0.5	6.5	47 ± 10%
6	4.50	0.6	7.8	68 ± 10%
9	6.75	0.9	11.7	160 ± 10%
12	9.00	1.2	15.6	275 ± 10%
18	13.5	1.8	23.4	650 ± 10%
24	18.0	2.4	31.2	1100 ± 10%
48	36.0	4.8	62.4	4170 ± 10%
60	45.0	6.0	78.0	7000 ± 10%

Note:When require pick-up voltage < 75% of nominal voltage, special order allowed.

CHARACTERISTICS

Initial Insulation Resistance	1000MΩ, 500 VDC	
Dielectric Strength	Between coil and Contacts	5000VAC 1min.
	Between contacts sets	3000VAC 1min.
	Between open contacts	1000VAC 1min.
Surge Voltage betweenContacts and coil	10000V(at 1.2 x 50 μs)	
Operate time (at nomi. Volt.)	15ms	
Release time (at nomi. Volt.)	5ms	
Humidity	98%, +40°C	
Ambient temperature	-40°C to +70°C	
Shock Resistance	Functional	100 m/s ²
	Destructive	1000 m/s ²
Vibration Resistance	1.5mm, 10 to 55Hz	
Termination	PCB	
Unit weight	Approx. 18g	
Construction	Sealed & Unsealed	

General Purpose Power Relays

JZX-140FF



ORDERING INFORMATION

JZX-140FF / 012 2H S

Type

Coil voltage 3,5,6,9,12,18,24, 48, 60VDC

Contact arrangement 2H:2 Form A 2Z:2 Form C

Structure Nil: Unsealed S: Sealed

OUTLINE DIMENSIONS, WIRING DIAGRAM AND PC BOARD LAYOUT

Outline Dimensions

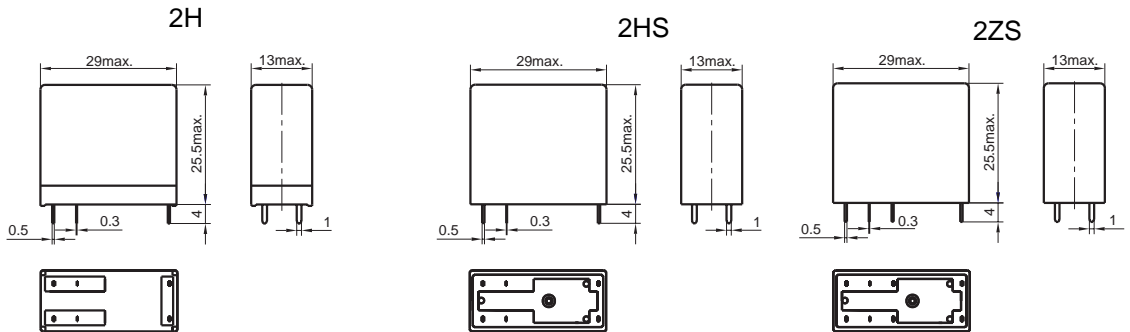

Wiring Diagram

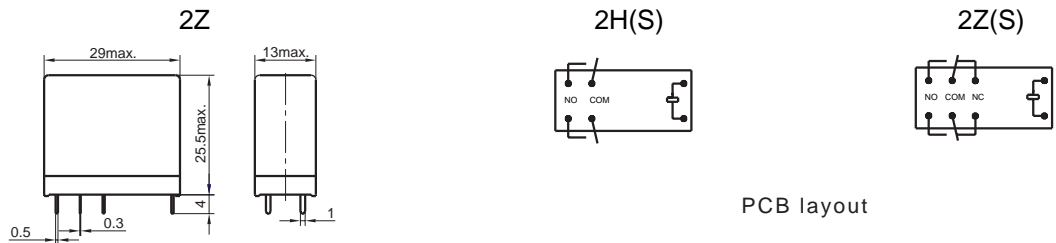

PCB layout

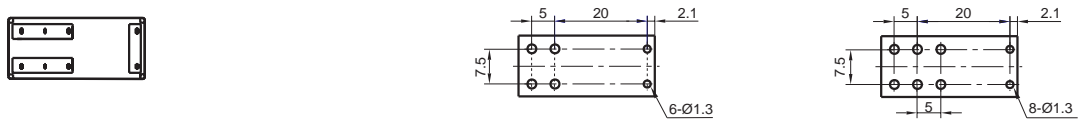

CHARACTERISTICS CURVE

