

> Features

- High Speed Switching
- Low On-Resistance
- No Secondary Breakdown
- Low Driving Power
- High Voltage
- VGS = ± 30V Guarantee
- Avalanche Proof

> Applications

- Switching Regulators
- UPS
- DC-DC converters
- General Purpose Power Amplifier

> Maximum Ratings and Characteristics

- Absolute Maximum Ratings (TC=25°C), unless otherwise specified

Item	Symbol	Rating	Unit
Drain-Source-Voltage	V <sub>DS</sub>	500	V
Drain-Gate-Voltage (R <sub>GS</sub> =20KΩ)	V <sub>DGR</sub>	500	V
Continous Drain Current	I <sub>D</sub>	10	A
Pulsed Drain Current	I <sub>D(puls)</sub>	40	A
Gate-Source-Voltage	V <sub>GS</sub>	±30	V
Max. Power Dissipation	P <sub>D</sub>	100	W
Operating and Storage Temperature Range	T <sub>ch</sub>	150	°C
	T <sub>stg</sub>	-55 ~ +150	°C

- Electrical Characteristics (TC=25°C), unless otherwise specified

Item	Symbol	Test conditions	Min.	Typ.	Max.	Unit
Drain-Source Breakdown-Voltage	V <sub>(BR)DSS</sub>	I <sub>D</sub> =1mA V <sub>GS</sub> =0V	500			V
Gate Threshold Voltage	V <sub>GS(th)</sub>	I <sub>D</sub> =1mA V <sub>DS</sub> =V <sub>GS</sub>	2,5	3,0	3,5	V
Zero Gate Voltage Drain Current	I <sub>DSS</sub>	V <sub>DS</sub> =500V T <sub>ch</sub> =25°C		10	500	μA
		V <sub>GS</sub> =0V T <sub>ch</sub> =125°C		0,2	1,0	mA
Gate Source Leakage Current	I <sub>GSS</sub>	V <sub>GS</sub> =±30V V <sub>DS</sub> =0V		10	100	nA
Drain Source On-State Resistance	R <sub>DS(on)</sub>	I <sub>D</sub> =5A V <sub>GS</sub> =10V		0,6	0,76	Ω
Forward Transconductance	g <sub>fs</sub>	I <sub>D</sub> =5A V <sub>DS</sub> =25V	5,0	10,0		S
Input Capacitance	C <sub>iss</sub>	V <sub>DS</sub> =25V		1500	2200	pF
Output Capacitance	C <sub>oss</sub>	V <sub>GS</sub> =0V		160	240	pF
Reverse Transfer Capacitance	C <sub>rss</sub>	f=1MHz		35	50	pF
Turn-On-Time t <sub>on</sub> (t <sub>on</sub> =t <sub>d(on)</sub> +t <sub>r</sub> )	t <sub>d(on)</sub>	V <sub>CC</sub> =300V		15	25	ns
	t <sub>r</sub>	I <sub>D</sub> =10A		40	60	ns
Turn-Off-Time t <sub>off</sub> (t <sub>off</sub> =t <sub>d(off)</sub> +t <sub>f</sub> )	t <sub>d(off)</sub>	V <sub>GS</sub> =10V		70	100	ns
	t <sub>f</sub>	R <sub>GS</sub> =10 Ω		60	90	ns
Avalanche Capability	I <sub>AV</sub>	L = 100μH T <sub>ch</sub> =25°C	10			A
Continous Reverse Drain Current	I <sub>DR</sub>				10	A
Pulsed Reverse Drain Current	I <sub>DRM</sub>				40	A
Diode Forward On-Voltage	V <sub>SD</sub>	I <sub>F</sub> =2xI <sub>DR</sub> V <sub>GS</sub> =0V T <sub>ch</sub> =25°C		1,12	1,70	V
Reverse Recovery Time	t <sub>rr</sub>	I <sub>F</sub> =I <sub>DR</sub> V <sub>GS</sub> =0V		450		ns
Reverse Recovery Charge	Q <sub>rr</sub>	-di <sub>F</sub> /dt=100A/μs T <sub>ch</sub> =25°C		3		μC

- Thermal Characteristics

Item	Symbol	Test conditions	Min.	Typ.	Max.	Unit
Thermal Resistance	R <sub>th(ch-a)</sub>	channel to air			35	°C/W
	R <sub>th(ch-c)</sub>	channel to case			1,25	°C/W

> Outline Drawing

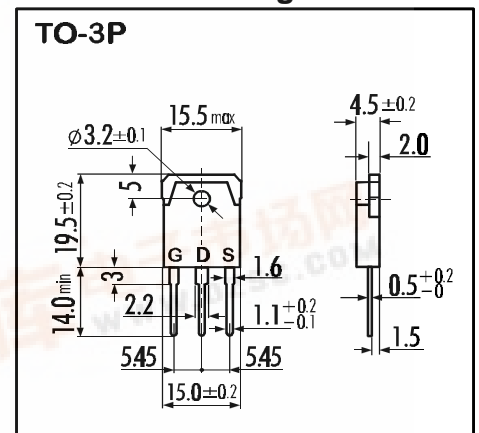

> Equivalent Circuit

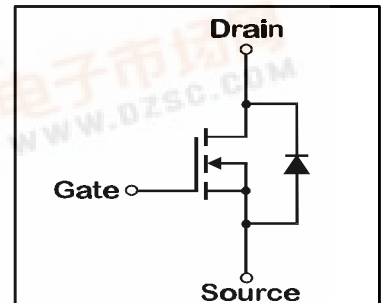

N-channel MOS-FET			
500V	0,76Ω	10A	100W

# 2SK1936-01

## FAP-IIA Series



### > Characteristics

Typical Output Characteristics

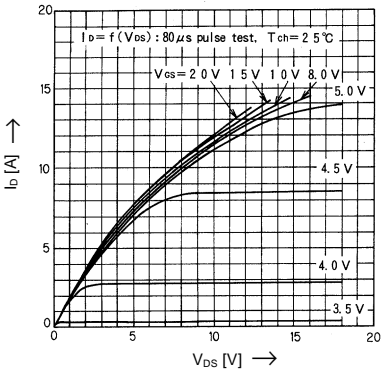

Drain-Source-On-State Resistance vs.  $T_{ch}$

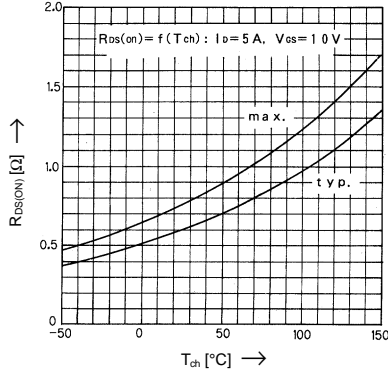

Typical Transfer Characteristics

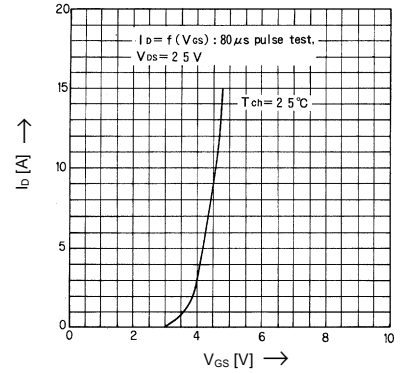

Typical Drain-Source-On-State-Resistance vs.  $I_D$

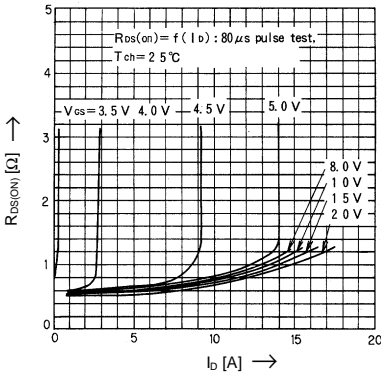

Typical Forward Transconductance vs.  $I_D$

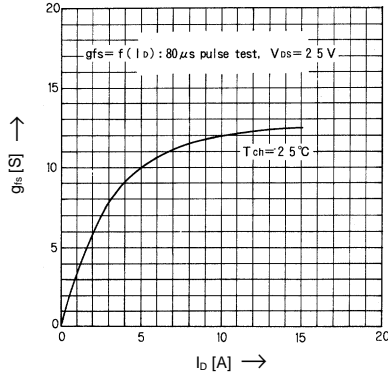

Gate Threshold Voltage vs.  $T_{ch}$

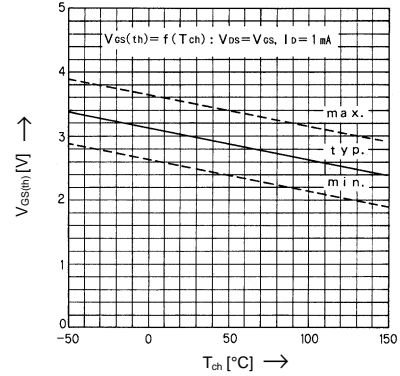

Typical Capacitance vs.  $V_{DS}$

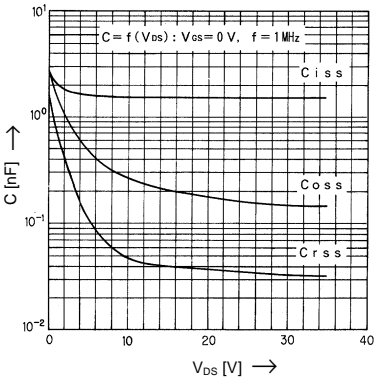

Typical Input Charge

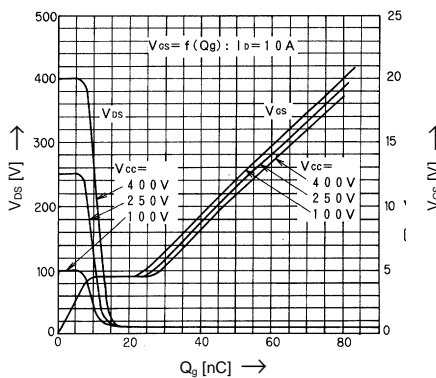

Forward Characteristics of Reverse Diode

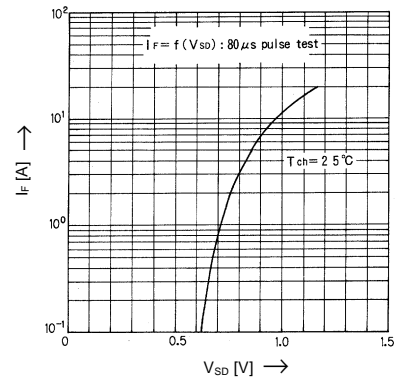

Allowable Power Dissipation vs.  $T_C$

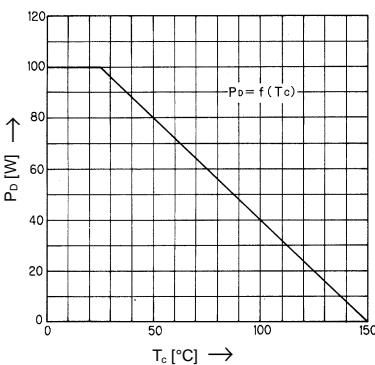

Safe operation area

