

> **Features**

- High Current
- Low On-Resistance
- No Secondary Breakdown
- Low Driving Power
- Avalanche Rated

> **Applications**

- Motor Control
- General Purpose Power Amplifier
- DC-DC converters

> **Outline Drawing**

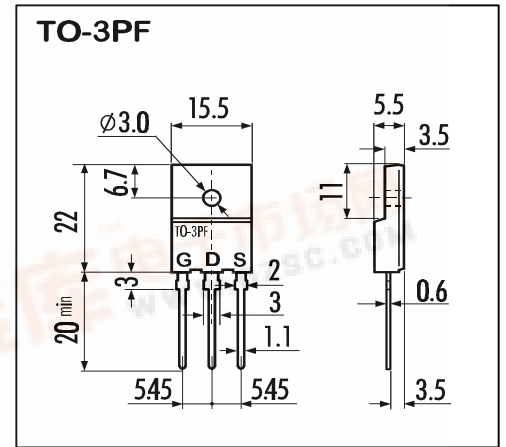

> **Maximum Ratings and Characteristics**

- Absolute Maximum Ratings (T_C=25°C), unless otherwise specified

Item	Symbol	Rating	Unit
Drain-Source-Voltage	V _{DS}	30	V
Continuous Drain Current	I _D	±90	A
Pulsed Drain Current	I _{D(puls)}	±350	A
Gate-Source-Voltage	V _{GS}	±16	V
Maximum Avalanche Energy	E _{AV}	1728.5	mJ*
Max. Power Dissipation	P _D	100	W
Operating and Storage Temperature Range	T _{ch}	150	°C
	T _{stg}	-55 ~ +150	°C

L=0.285mH, V_{cc}=12V

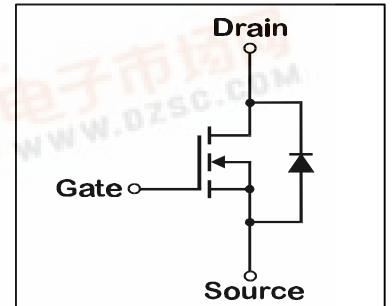

- Electrical Characteristics (T_C=25°C), unless otherwise specified

Item	Symbol	Test conditions	Min.	Typ.	Max.	Unit
Drain-Source Breakdown-Voltage	BV _{DSS}	I _D =1mA V _{GS} =0V	30			V
Gate Threshold Voltage	V _{GS(th)}	I _D =1mA V _{DS} =V _{GS}	1,0	1,5	2,0	V
Zero Gate Voltage Drain Current	I _{DSS}	V _{DS} =30V T _{ch} =25°C		10	500	μA
		V _{GS} =0V T _{ch} =125°C		0,2	1,0	mA
Gate Source Leakage Current	I _{GSS}	V _{GS} =±16V V _{DS} =0V		10	100	nA
Drain Source On-State Resistance	R _{DS(on)}	I _D =50A V _{GS} =4V		7,0	9,5	mΩ
		I _D =50A V _{GS} =10V		4,4	5,5	mΩ
Forward Transconductance	g _{fs}	I _D =50A V _{DS} =25V	35	70		S
Input Capacitance	C _{iss}	V _{DS} =25V		3900	5850	pF
Output Capacitance	C _{oss}	V _{GS} =0V		2000	3000	pF
Reverse Transfer Capacitance	C _{rss}	f=1MHz		850	1280	pF
Turn-On-Time t _{on} (t _{on} =t _{d(on)} +t _r)	t _{d(on)}	V _{CC} =15V		17	30	ns
		V _{GS} =10V		70	110	ns
Turn-Off-Time t _{off} (t _{off} =t _{d(off)} +t _f)	t _{d(off)}	I _D =100A		250	380	ns
		R _{GS} =10 Ω		180	270	ns
Avalanche Capability	I _{AV}	L = 100μH T _{ch} =25°C	90			A
Diode Forward On-Voltage	V _{SD}	I _F =50A V _{GS} =0V T _{ch} =25°C		1,0	1,5	V
Reverse Recovery Time	t _{rr}	I _F =50A V _{GS} =0V		65		ns
Reverse Recovery Charge	Q _{rr}	-di/dt=100A/μs T _{ch} =25°C		0,12		μC

- Thermal Characteristics

Item	Symbol	Min.	Typ.	Max.	Unit
Thermal Resistance	R _{th(ch-c)}			1,25	°C/W
	R _{th(ch-a)}			30,0	°C/W

N-channel MOS-FET			
30V	5,5mΩ	±90A	100W

2SK2892-01R

FAP-III B Series



> Characteristics

Typical Output Characteristics

$I_b = f(V_{DS})$; 80μs pulse test; $T_c = 25^\circ\text{C}$

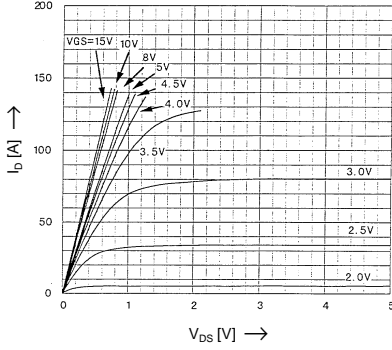

Drain-Source On-State Resistance vs. T_{ch}

$R_{DS(on)} = f(T_{ch})$; $I_b = 50\text{A}$; $V_{GS} = 10\text{V}$

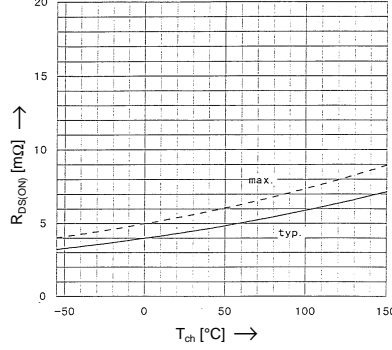

Typical Transfer Characteristics

$I_b = f(V_{GS})$; 80μs pulse test; $V_{DS} = 25\text{V}$; $T_c = 25^\circ\text{C}$

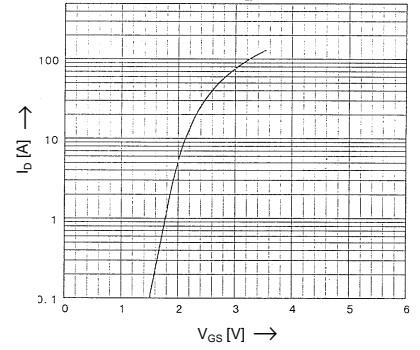

Typical Drain-Source On-State-Resistance vs. I_b

$R_{DS(on)} = f(I_b)$; 80μs pulse test; $T_c = 25^\circ\text{C}$

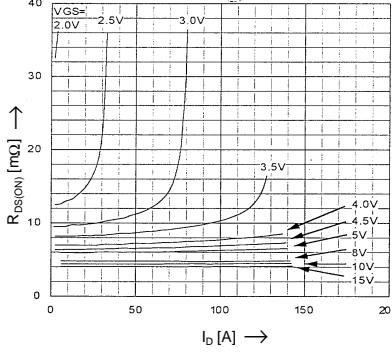

Typical Forward Transconductance vs. I_b

$g_{fs} = f(I_b)$; 80μs pulse test; $V_{DS} = 25\text{V}$; $T_c = 25^\circ\text{C}$

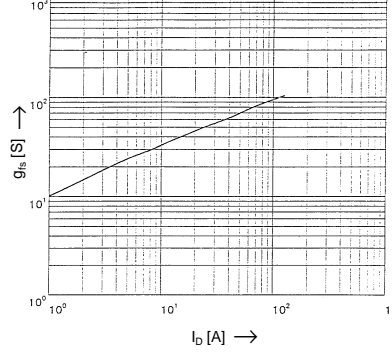

Gate Threshold Voltage vs. T_{ch}

$V_{GS(th)} = f(T_{ch})$; $I_b = 1\text{mA}$; $V_{DS} = V_{GS}$

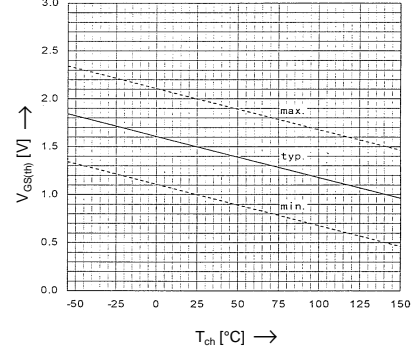

Typical Capacitances vs. V_{DS}

$C = f(V_{DS})$; $V_{GS} = 0\text{V}$; $f = 1\text{MHz}$

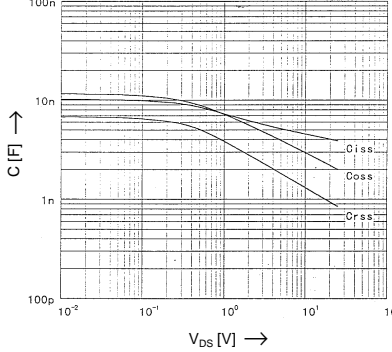

Typical Gate Charge Characteristic

$V_{GS} = f(Q_g)$; $I_b = 100\text{A}$; $T_c = 25^\circ\text{C}$

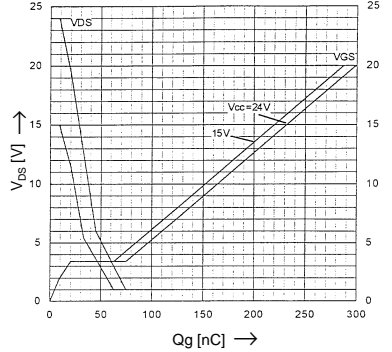

Forward Characteristics of Reverse Diode

$I_F = f(V_{SD})$; 80μs pulse test; $T_c = 25^\circ\text{C}$

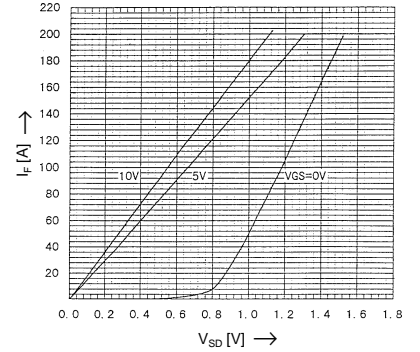

Maximum Avalanche Energy vs. starting T_{ch}

$E_{AV} = f(\text{starting } T_{ch})$; $V_{CC} = 24\text{V}$; $I_{AV} \leq 45\text{A}$

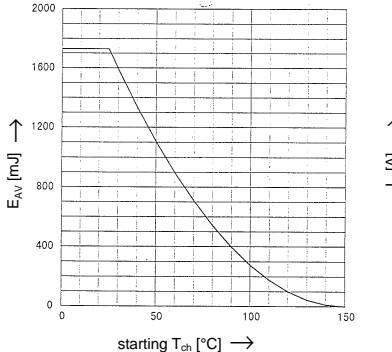

Safe Operation Area

$I_b = f(V_{DS})$; $D = 0.01$; $T_c = 25^\circ\text{C}$

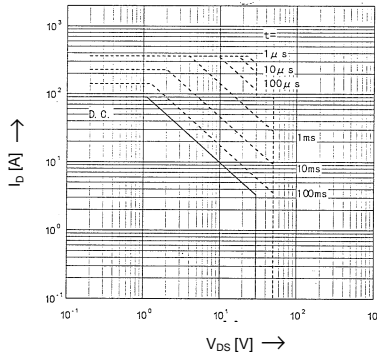

Transient Thermal impedance

$Z_{th(ch-c)} = f(t)$ parameter: $D = t/T$

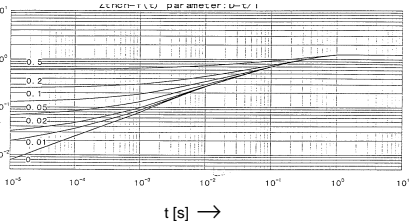

N-channel MOS-FET			
30V	5,5mΩ	±90A	100W

2SK2892-01R

FAP-III B Series



> Characteristics

