

## K6F2008U2E Family

## CMOS SRAM

### Document Title

256Kx8 bit Super Low Power and Low Voltage Full CMOS Static RAM

### Revision History

<u>Revision No.</u>	<u>History</u>	<u>Draft Date</u>	<u>Remark</u>
0.0	Initial Draft	February 28, 2001	Preliminary
1.0	Finalize	September 27, 2001	Final
2.0	Revise - Added 48(36)-TBGA-6.00x7.00 products.	April 30, 2002	Final

The attached datasheets are provided by SAMSUNG Electronics. SAMSUNG Electronics CO., LTD. reserve the right to change the specifications and products. SAMSUNG Electronics will answer to your questions about device. If you have any questions, please contact the SAMSUNG branch offices.

# K6F2008U2E Family

# CMOS SRAM

## 256Kx8 bit Super Low Power and Low Voltage Full CMOS Static RAM

### FEATURES

- Process Technology: Full CMOS
- Organization: 256Kx8
- Power Supply Voltage: 2.7~3.3V
- Low Data Retention Voltage: 1.5V(Min)
- Three State Outputs
- Package Type: 32-TSOP1-0813.4F, 48(36)-TBGA-6.00x7.00

### GENERAL DESCRIPTION

The K6F2008U2E families are fabricated by SAMSUNG's advanced Full CMOS process technology. The families support various operating temperature ranges and have various package types for user flexibility of system design. The families also supports low data retention voltage for battery back-up operation with low data retention current.

### PRODUCT FAMILY

Product Family	Operating Temperature	Vcc Range	Speed(ns)	Power Dissipation		PKG Type
				Standby (I <sub>sb1</sub> , Typ.)	Operating (I <sub>cc1</sub> , Max)	
K6F2008U2E-F	Industrial(-40~85°C)	2.7~3.3V	55 <sup>1)</sup> /70ns	0.5μA <sup>2)</sup>	2mA	32-TSOP1-0813.4F 48(36)-TBGA-6.00x7.00

1. The parameter is measured with 30pF test load.
2. Typical values are measured at V<sub>cc</sub>=3.0V, T<sub>A</sub>=25°C and not 100% tested.

### PIN DESCRIPTION

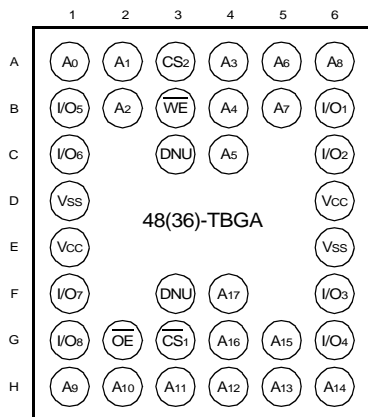
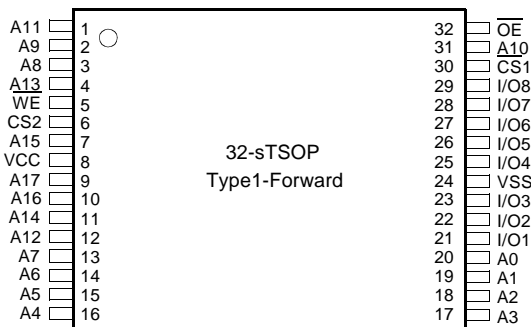

### FUNCTIONAL BLOCK DIAGRAM

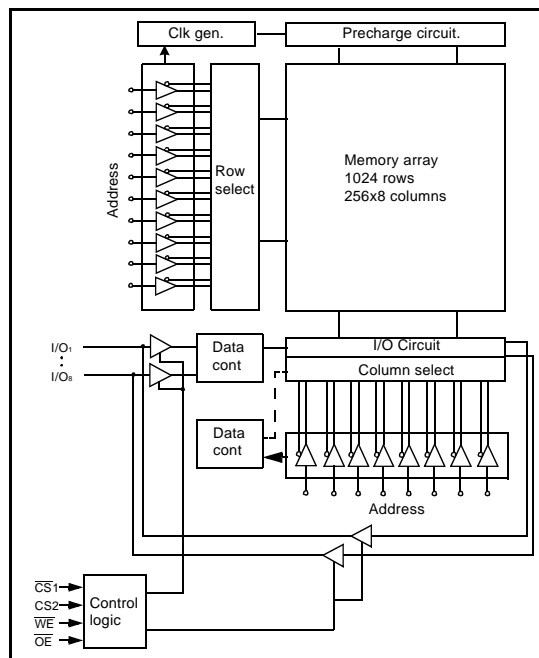

Name	Function	Name	Function
CS1, CS2	Chip Select Input	I/O1~I/O8	Data Inputs/Outputs
OE	Output Enable	Vcc	Power
WE	Write Enable Input	Vss	Ground
A0~A17	Address Inputs		

SAMSUNG ELECTRONICS CO., LTD. reserves the right to change products and specifications without notice.

**PRODUCT LIST**

Industrial Temperature Products(-40~85°C)	
Part Name	Function
K6F2008U2E-YF55	32-sTSOP1-F, 55ns, 3.0V, LL
K6F2008U2E-YF70	32-sTSOP1-F, 70ns, 3.0V, LL
K6F2008U2E-EF55	48(36)-TBGA, 55ns, 3.0V, LL
K6F2008U2E-EF70	48(36)-TBGA, 70ns, 3.0V, LL

**FUNCTIONAL DESCRIPTION**

CS <sub>1</sub>	CS <sub>2</sub>	OE	WE	I/O	Mode	Power
H	X <sup>1)</sup>	X <sup>1)</sup>	X <sup>1)</sup>	High-Z	Deselected	Standby
X <sup>1)</sup>	L	X <sup>1)</sup>	X <sup>1)</sup>	High-Z	Deselected	Standby
L	H	H	H	High-Z	Output Disable	Active
L	H	L	H	Dout	Read	Active
L	H	X <sup>1)</sup>	L	Din	Write	Active

1. X means don't care (Must be high or low states)

**ABSOLUTE MAXIMUM RATINGS<sup>1)</sup>**

Item	Symbol	Ratings	Unit
Voltage on any pin relative to V <sub>ss</sub>	V <sub>IN</sub> , V <sub>OUT</sub>	-0.2 to V <sub>CC</sub> +0.3V	V
Voltage on V <sub>CC</sub> supply relative to V <sub>ss</sub>	V <sub>CC</sub>	-0.2 to 3.6V	V
Power Dissipation	P <sub>D</sub>	1.0	W
Storage temperature	T <sub>STG</sub>	-65 to 150	°C
Operating Temperature	T <sub>A</sub>	-40 to 85	°C

1. Stresses greater than those listed under "Absolute Maximum Ratings" may cause permanent damage to the device. Functional operation should be restricted to recommended operating condition. Exposure to absolute maximum rating conditions for extended periods may affect reliability.

**RECOMMENDED DC OPERATING CONDITIONS<sup>1)</sup>**

Item	Symbol	Min	Typ	Max	Unit
Supply voltage	V <sub>CC</sub>	2.7	3.0	3.3	V
Ground	V <sub>SS</sub>	0	0	0	V
Input high voltage	V <sub>IH</sub>	2.2	-	V <sub>CC</sub> +0.2 <sup>2)</sup>	V
Input low voltage	V <sub>IL</sub>	-0.2 <sup>3)</sup>	-	0.6	

Note:

1. Industrial Product: T<sub>A</sub>=-40 to 85°C, unless otherwise specified
2. Overshoot: V<sub>CC</sub>+2.0V in case of pulse width≤20ns
3. Undershoot: -2.0V in case of pulse width≤20ns
4. Overshoot and undershoot are sampled, not 100% tested.

**CAPACITANCE<sup>1)</sup>** (f=1MHz, T<sub>A</sub>=25°C)

Item	Symbol	Test Condition	Min	Max	Unit
Input capacitance	C <sub>IN</sub>	V <sub>IN</sub> =0V	-	8	pF
Input/Output capacitance	C <sub>IO</sub>	V <sub>IO</sub> =0V	-	10	pF

1. Capacitance is sampled, not 100% tested.

**DC AND OPERATING CHARACTERISTICS**

Item	Symbol	Test Conditions	Min	Typ <sup>1)</sup>	Max	Unit
Input leakage current	I <sub>LI</sub>	V <sub>IN</sub> =V <sub>SS</sub> to V <sub>CC</sub>	-1	-	1	μA
Output leakage current	I <sub>LO</sub>	$\overline{CS}_1=V_{IH}$ or $CS_2=V_{IL}$ or $\overline{OE}=V_{IH}$ or $\overline{WE}=V_{IL}$ , V <sub>IO</sub> =V <sub>SS</sub> to V <sub>CC</sub>	-1	-	1	μA
Average operating current	I <sub>CC1</sub>	Cycle time=1μs, 100% duty, I <sub>IO</sub> =0mA, $\overline{CS}_1 \leq 0.2V$ , $CS_2 \geq V_{CC}-0.2V$ , V <sub>IN</sub> ≤0.2V or V <sub>IN</sub> ≥V <sub>CC</sub> -0.2V	-	-	2	mA
	I <sub>CC2</sub>	Cycle time=Min, 100% duty, I <sub>IO</sub> =0mA, $\overline{CS}_1=V_{IL}$ , $CS_2=V_{IH}$ , V <sub>IN</sub> =V <sub>IL</sub> or V <sub>IH</sub>	70ns	-	-	15
55ns			-	-	20	mA
Output low voltage	V <sub>OL</sub>	I <sub>OL</sub> =2.1mA	-	-	0.4	V
Output high voltage	V <sub>OH</sub>	I <sub>OH</sub> =-1.0mA	2.4	-	-	V
Standby Current(CMOS)	I <sub>SB1</sub>	Other inputs=V <sub>SS</sub> to V <sub>CC</sub> 1) $\overline{CS}_1 \geq V_{CC}-0.2V$ , $CS_2 \geq V_{CC}-0.2V$ ( $\overline{CS}_1$ controlled) or 2) $0V \leq CS_2 \leq 0.2V$ $CS_2$ controlled)	-	0.5	10	μA

1. Typical value are measured at V<sub>CC</sub>=3.0V, T<sub>A</sub>=25°C, and not 100% tested.

**AC OPERATING CONDITIONS**

**TEST CONDITIONS**(Test Load and Test Input/Output Reference)

Input pulse level: 0.4 to 2.2V  
 Input rising and falling time: 5ns  
 Input and output reference voltage: 1.5V  
 Output load (See right):  $C_L=100pF+1TTL$   
 $C_L=30pF+1TTL$

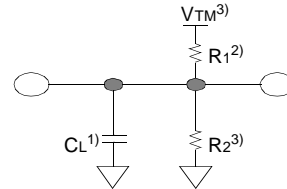

1. Including scope and jig capacitance
2.  $R_1=3070\Omega$ ,  $R_2=3150\Omega$
3.  $V_{TM}=2.8V$

**AC CHARACTERISTICS**( $V_{CC}=2.7\sim 3.3V$ , Industrial product:  $T_A=-40$  to  $85^\circ C$ )

Parameter List	Symbol	Speed Bins				Units	
		55ns <sup>1)</sup>		70ns			
		Min	Max	Min	Max		
Read	Read Cycle Time	t <sub>RC</sub>	55	-	70	-	ns
	Address Access Time	t <sub>AA</sub>	-	55	-	70	ns
	Chip Select to Output	t <sub>CO</sub>	-	55	-	70	ns
	Output Enable to Valid Output	t <sub>OE</sub>	-	25	-	35	ns
	Chip Select to Low-Z Output	t <sub>LZ</sub>	10	-	10	-	ns
	Output Enable to Low-Z Output	t <sub>OLZ</sub>	5	-	5	-	ns
	Chip Disable to High-Z Output	t <sub>HZ</sub>	0	20	0	25	ns
	Output Disable to High-Z Output	t <sub>OHZ</sub>	0	20	0	25	ns
	Output Hold from Address Change	t <sub>OH</sub>	10	-	10	-	ns
Write	Write Cycle Time	t <sub>WC</sub>	55	-	70	-	ns
	Chip Select to End of Write	t <sub>CW</sub>	45	-	60	-	ns
	Address Set-up Time	t <sub>AS</sub>	0	-	0	-	ns
	Address Valid to End of Write	t <sub>AW</sub>	45	-	60	-	ns
	Write Pulse Width	t <sub>WP</sub>	40	-	50	-	ns
	Write Recovery Time	t <sub>WR</sub>	0	-	0	-	ns
	Write to Output High-Z	t <sub>WHZ</sub>	0	20	0	20	ns
	Data to Write Time Overlap	t <sub>DW</sub>	25	-	30	-	ns
	Data Hold from Write Time	t <sub>DH</sub>	0	-	0	-	ns
	End Write to Output Low-Z	t <sub>OW</sub>	5	-	5	-	ns

1. The parameter is measured with 30pF test load.

**DATA RETENTION CHARACTERISTICS**

Item	Symbol	Test Condition	Min	Typ <sup>2)</sup>	Max	Unit
V <sub>CC</sub> for data retention	V <sub>DR</sub>	$\overline{CS}_1 \geq V_{CC}-0.2V^1)$	1.5	-	3.3	V
Data retention current	I <sub>DR</sub>	$V_{CC}=1.5V, \overline{CS}_1 \geq V_{CC}-0.2V^1)$	-	0.5	2	$\mu A$
Data retention set-up time	t <sub>SDR</sub>	See data retention waveform	0	-	-	ns
Recovery time	t <sub>RDR</sub>		t <sub>RC</sub>	-	-	

1. 1)  $\overline{CS}_1 \geq V_{CC}-0.2V$ ,  $\overline{CS}_2 \geq V_{CC}-0.2V$  ( $\overline{CS}_1$  controlled) or  
 2)  $0 \leq \overline{CS}_2 \leq 0.2V$  ( $\overline{CS}_2$  controlled).
2. Typical value are measured at  $T_A=25^\circ C$  and not 100% tested.

TIMING DIAGRAMS

TIMING WAVEFORM OF READ CYCLE(1) (Address Controlled,  $\overline{CS1}=\overline{OE}=V_{IL}$ ,  $\overline{WE}=V_{IH}$ )

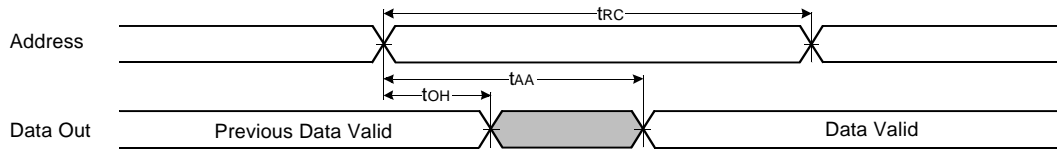

TIMING WAVEFORM OF READ CYCLE(2) ( $\overline{WE}=V_{IH}$ )

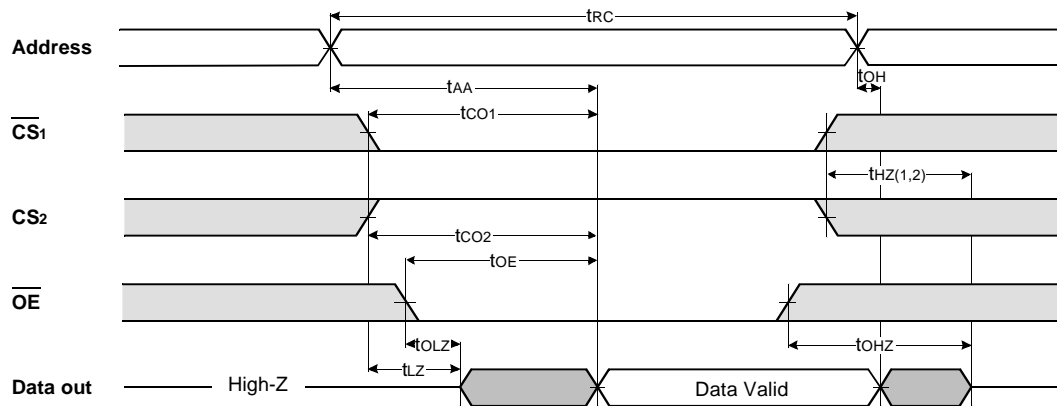

NOTES (READ CYCLE)

1.  $t_{HZ}$  and  $t_{OHZ}$  are defined as the time at which the outputs achieve the open circuit conditions and are not referenced to output voltage levels.
2. At any given temperature and voltage condition,  $t_{HZ}(\text{Max.})$  is less than  $t_{LZ}(\text{Min.})$  both for a given device and from device to device interconnection.

TIMING WAVEFORM OF WRITE CYCLE(1) ( $\overline{WE}$  Controlled)

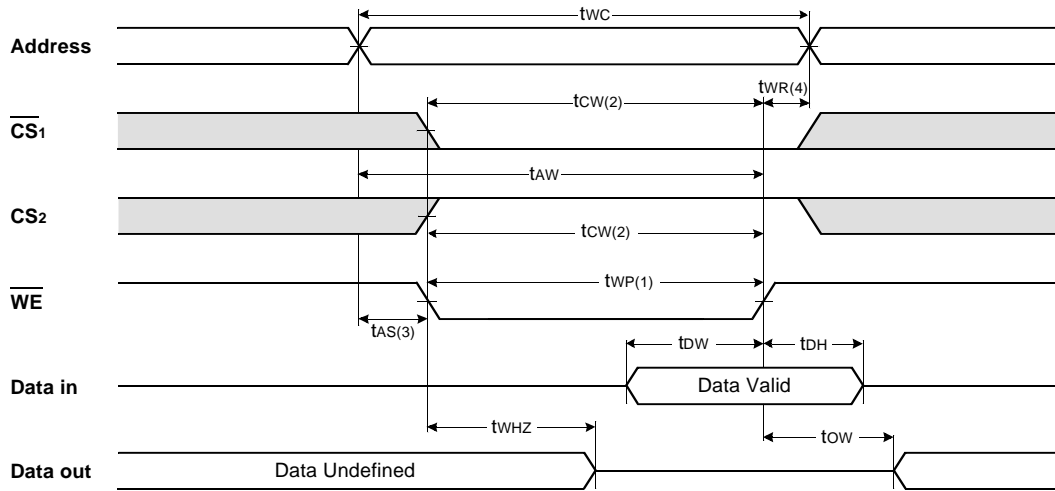

TIMING WAVEFORM OF WRITE CYCLE(2) ( $\overline{CS1}$  Controlled)

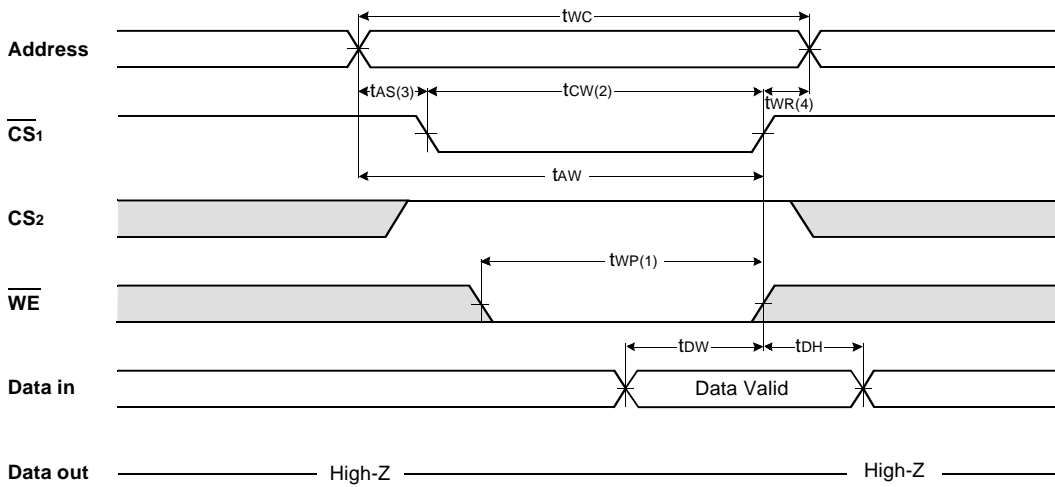

TIMING WAVEFORM OF WRITE CYCLE(3) (CS<sub>2</sub> Controlled)

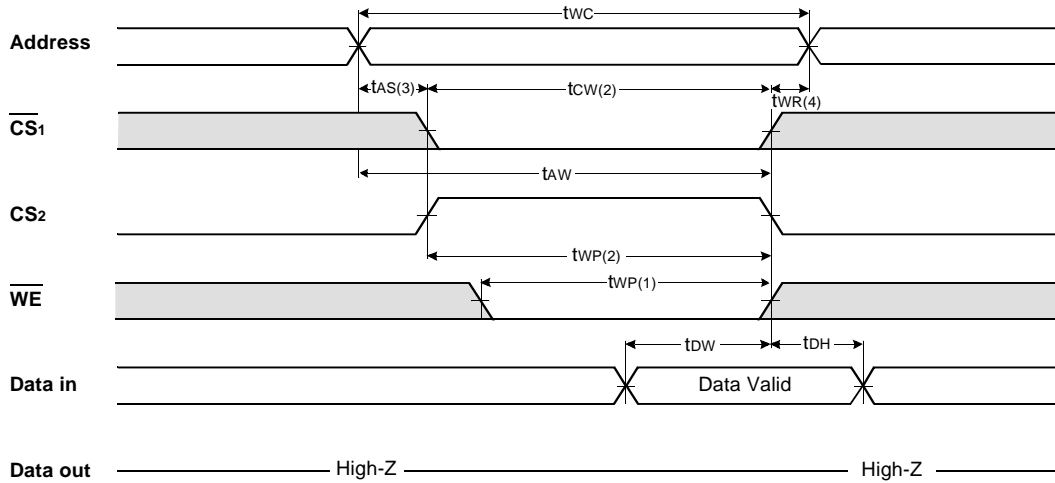

NOTES (WRITE CYCLE)

1. A write occurs during the overlap of a low  $\overline{CS}_1$ , a high  $CS_2$  and a low  $\overline{WE}$ . A write begins at the latest transition among  $\overline{CS}_1$  goes low,  $CS_2$  going high and  $\overline{WE}$  going low : A write end at the earliest transition among  $\overline{CS}_1$  going high,  $CS_2$  going low and  $\overline{WE}$  going high,  $t_{WP}$  is measured from the beginning of write to the end of write.
2.  $t_{CW}$  is measured from the  $\overline{CS}_1$  going low or  $CS_2$  going high to the end of write.
3.  $t_{AS}$  is measured from the address valid to the beginning of write.
4.  $t_{WR}$  is measured from the end of write to the address change.  $t_{WR(1)}$  applied in case a write ends as  $\overline{CS}_1$  or  $\overline{WE}$  going high  $t_{WR(2)}$  applied in case a write ends as  $CS_2$  going to low.

DATA RETENTION WAVE FORM

$\overline{CS}_1$  controlled

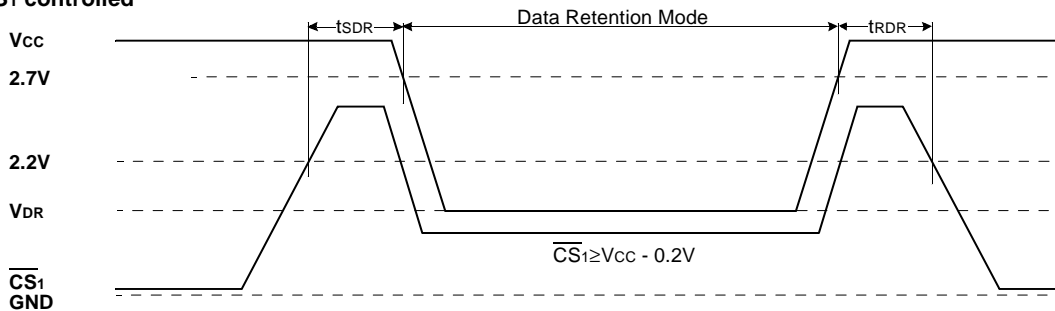

$CS_2$  controlled

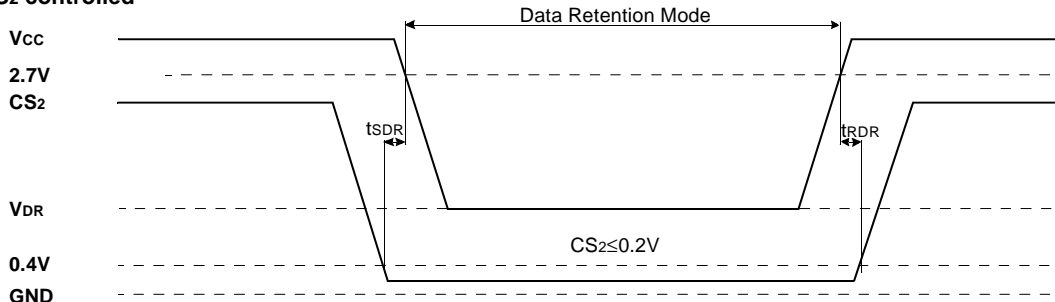



# K6F208U2E Family

# CMOS SRAM

## PACKAGE DIMENSIONS

Units: millimeters(inches)

### 32 PIN THIN SMALL OUTLINE PACKAGE TYPE I (0813.4F)

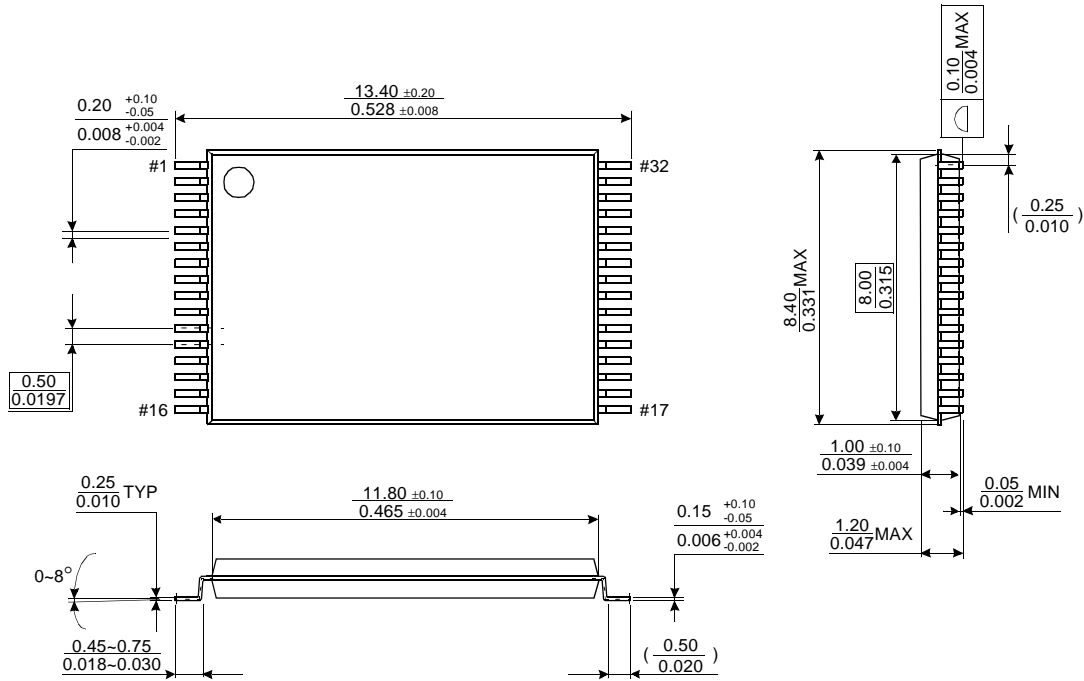

PACKAGE DIMENSIONS

Units: millimeters

48(36) TAPE BALL GRID ARRAY(0.75mm ball pitch)

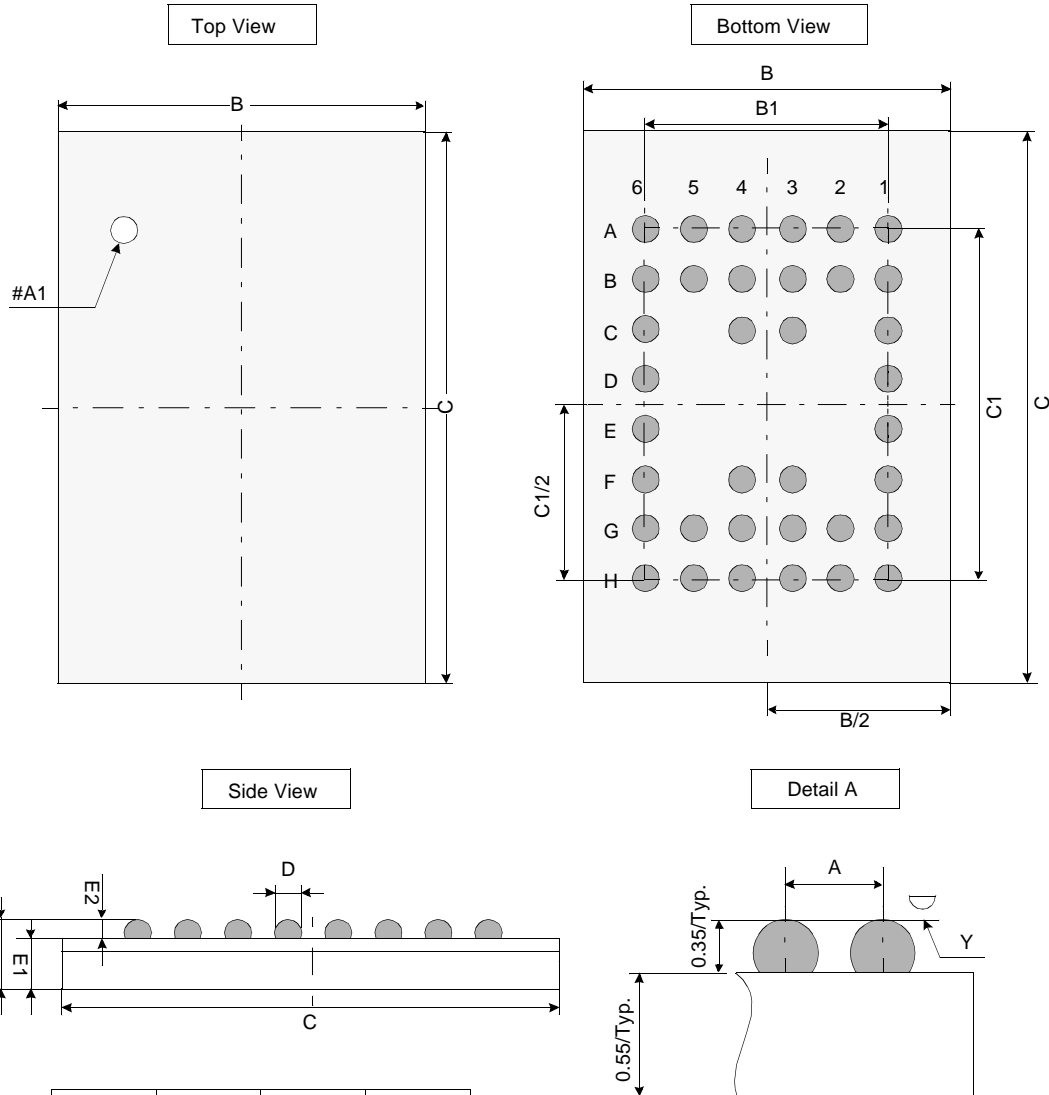

	Min	Typ	Max
A	-	0.75	-
B	5.90	6.00	6.10
B1	-	3.75	-
C	6.90	7.00	7.10
C1	-	5.25	-
D	0.40	0.45	0.50
E	0.80	0.90	1.00
E1	-	0.55	-
E2	0.30	0.35	0.40
Y	-	-	0.08

Notes.

1. Bump counts: 48(8 row x 6 column)
2. Bump pitch: (x,y)=(0.75 x 0.75)(typ.)
3. All tolerance are +/-0.050 unless otherwise specified.
4. Typ: Typical
5. Y is coplanarity: 0.08(Max)