



K814P/ K824P/ K844P

Vishay Telefunken

Optocoupler with Phototransistor Output

Description

The K814P/K824P/K844P consist of a phototransistor optically coupled to 2 gallium arsenide infrared-emitting diodes (reversed polarity) in an 4-lead up to 16-lead plastic dual inline package. The elements are mounted on one leadframe using a **coplanar technique**, providing a fixed distance between input and output for highest safety requirements.

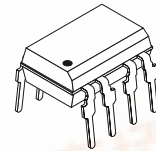
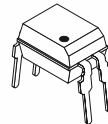
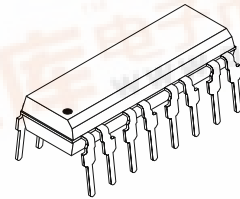

Applications

Feature phones, answering machines, PABX, fax machines

Features

- Endstackable to 2.54 mm (0.1") spacing
- DC isolation test voltage $V_{IO} = 5 \text{ kV}$
- Low coupling capacitance of typical 0.3 pF
- **Current Transfer Ratio (CTR)** of typical 100%
- Low temperature coefficient of CTR
- Wide ambient temperature range
- Underwriters Laboratory (UL) 1577 recognized, file number E-76222
- **CSA (C-UL)** 1577 recognized, file number E-76222 – Double Protection
- Coupling System U

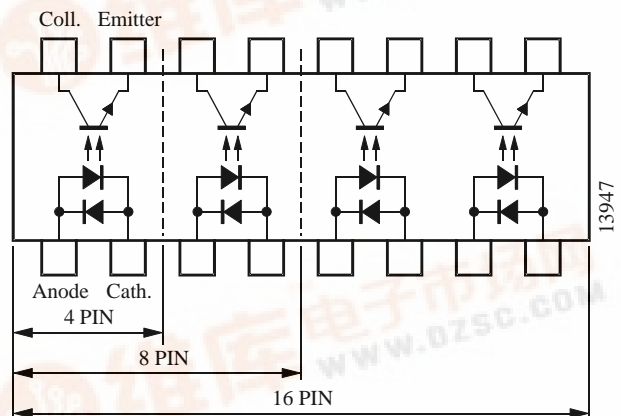

Order Instruction

Ordering Code	CTR Ranking	Remarks
K814P	< 20%	4 Pin Single channel
K824P	< 20%	8 Pin Dual channel
K844P	< 20%	16 Pin Quad channel

K814P/ K824P/ K844P

Vishay Telefunken



Absolute Maximum Ratings

Input (Emitter)

Parameter	Test Conditions	Symbol	Value	Unit
Reverse voltage		V_R	6	V
Forward current		I_F	± 60	mA
Forward surge current	$t_p \leq 10 \mu\text{s}$	I_{FSM}	± 1.5	A
Power dissipation	$T_{amb} \leq 25^\circ\text{C}$	P_V	100	mW
Junction temperature		T_j	125	$^\circ\text{C}$

Output (Detector)

Parameter	Test Conditions	Symbol	Value	Unit
Collector emitter voltage		V_{CEO}	70	V
Emitter collector voltage		V_{ECO}	7	V
Collector current		I_C	50	mA
Peak collector current	$t_p/T = 0.5, t_p \leq 10 \text{ ms}$	I_{CM}	100	mA
Power dissipation	$T_{amb} \leq 25^\circ\text{C}$	P_V	150	mW
Junction temperature		T_j	125	$^\circ\text{C}$

Coupler

Parameter	Test Conditions	Symbol	Value	Unit
AC Isolation test voltage (RMS)	$t = 1 \text{ min}$	$V_{IO}^{1)}$	5	kV
Total power dissipation	$T_{amb} \leq 25^\circ\text{C}$	P_{tot}	250	mW
Operating ambient temperature range		T_{amb}	-40 to +100	$^\circ\text{C}$
Storage temperature range		T_{stg}	-55 to +125	$^\circ\text{C}$
Soldering temperature	2 mm from case, $t \leq 10 \text{ s}$	T_{sd}	260	$^\circ\text{C}$

¹⁾ Related to standard climate 23/50 DIN 50014



Electrical Characteristics ($T_{amb} = 25^{\circ}\text{C}$)

Input (Emitter)

Parameter	Test Conditions	Symbol	Min.	Typ.	Max.	Unit
Forward voltage	$I_F = \pm 50 \text{ mA}$	V_F		1.25	1.6	V
Reverse current	$V_R = \pm 6 \text{ V}$	I_R			10	μA

Output (Detector)

Parameter	Test Conditions	Symbol	Min.	Typ.	Max.	Unit
Collector emitter voltage	$I_C = 100 \mu\text{A}$	V_{CEO}	70			V
Emitter collector voltage	$I_E = 100 \mu\text{A}$	V_{ECO}	7			V
Collector dark current	$V_{CE} = 20 \text{ V}, I_F = 0, E = 0$	I_{CEO}			100	nA

Coupler

Parameter	Test Conditions	Symbol	Min.	Typ.	Max.	Unit
Collector emitter saturation voltage	$I_F = \pm 10 \text{ mA}, I_C = 1 \text{ mA}$	V_{CEsat}			0.3	V
Cut-off frequency	$I_F = \pm 10 \text{ mA}, V_{CE} = 5 \text{ V}, R_L = 100 \Omega$	f_c		100		kHz
Coupling capacitance	$f = 1 \text{ MHz}$	C_k		0.3		pF

Current Transfer Ratio (CTR)

Parameter	Test Conditions	Type	Symbol	Min.	Typ.	Max.	Unit
I_C/I_F	$V_{CE} = 5 \text{ V}, I_F = \pm 5 \text{ mA}$		CTR	0.2		3.0	



Switching Characteristics

Parameter	Test Conditions	Symbol	Typ.	Unit
Delay time	$V_S = 5\text{ V}$, $I_C = 2\text{ mA}$, $R_L = 100\ \Omega$ (see figure 1)	t_d	3.0	μs
Rise time		t_r	3.0	μs
Fall time		t_f	4.7	μs
Storage time		t_s	0.3	μs
Turn-on time		t_{on}	6.0	μs
Turn-off time		t_{off}	5.0	μs
Turn-on time	$V_S = 5\text{ V}$, $I_F = 10\text{ mA}$, $R_L = 1\text{ k}\Omega$ (see figure 2)	t_{on}	9.0	μs
Turn-off time		t_{off}	18.0	μs

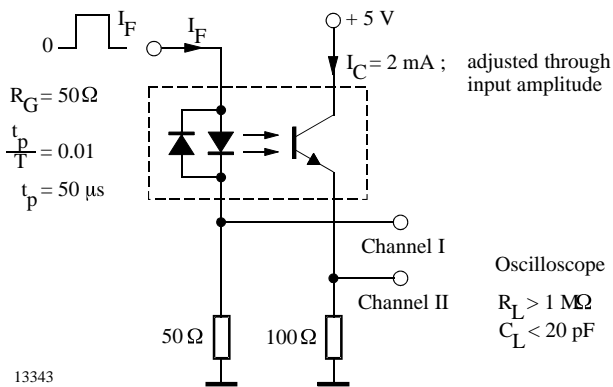

Figure 1. Test circuit, non-saturated operation

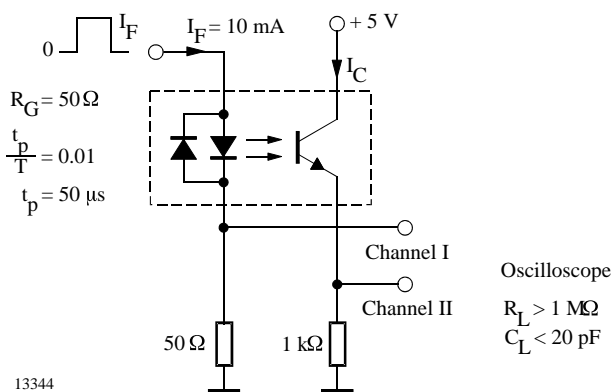

Figure 2. Test circuit, saturated operation

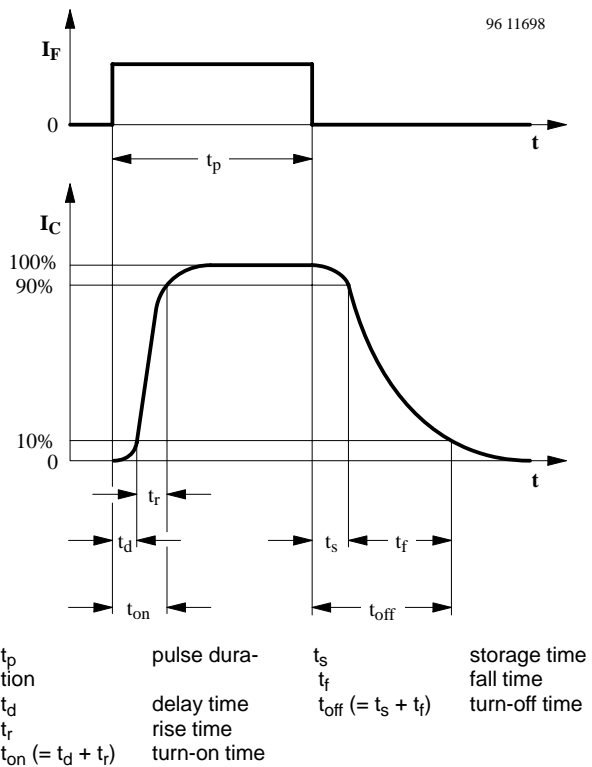
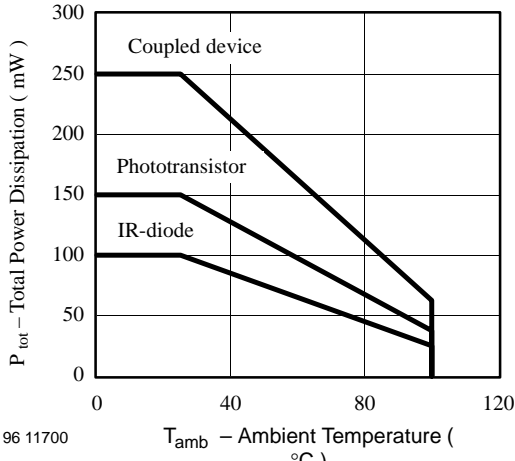

Figure 3. Switching times



Typical Characteristics ($T_{amb} = 25^{\circ}C$, unless otherwise specified)



96 11700
Figure 4. Total Power Dissipation vs. Ambient Temperature

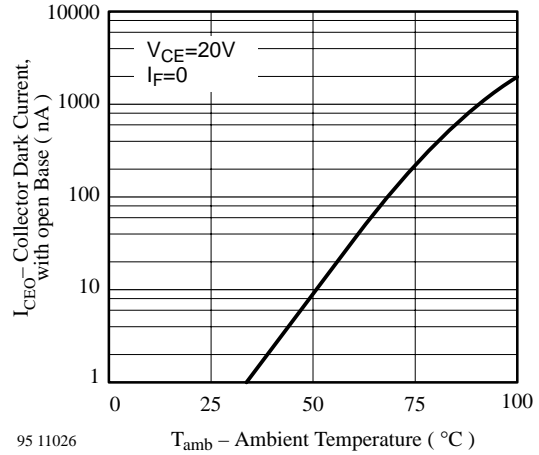

95 11026
Figure 7. Collector Dark Current vs. Ambient Temperature

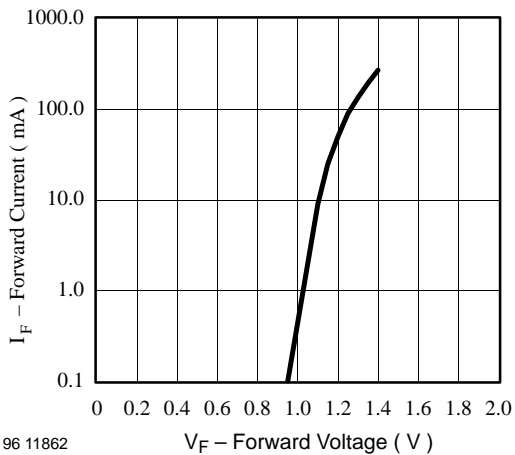

96 11862
Figure 5. Forward Current vs. Forward Voltage

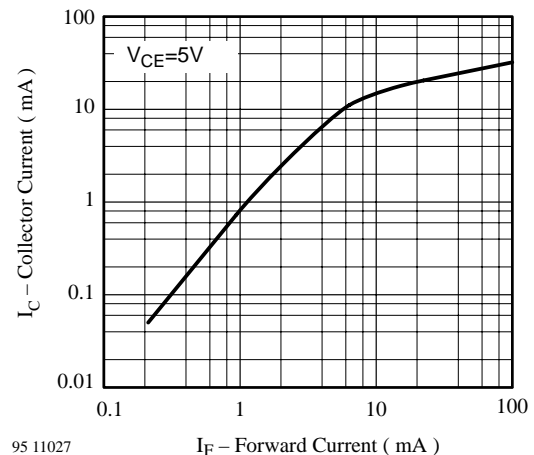

95 11027
Figure 8. Collector Current vs. Forward Current

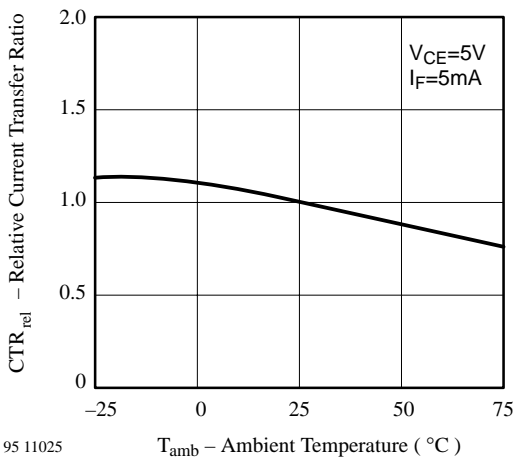

95 11025
Figure 6. Relative Current Transfer Ratio vs. Ambient Temperature

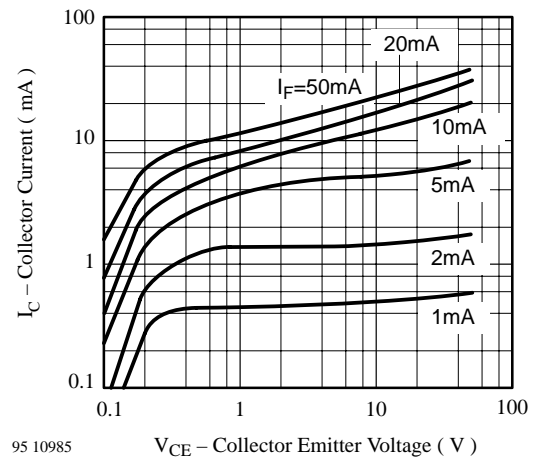

95 10985
Figure 9. Collector Current vs. Collector Emitter Voltage

K814P/ K824P/ K844P

Vishay Telefunken

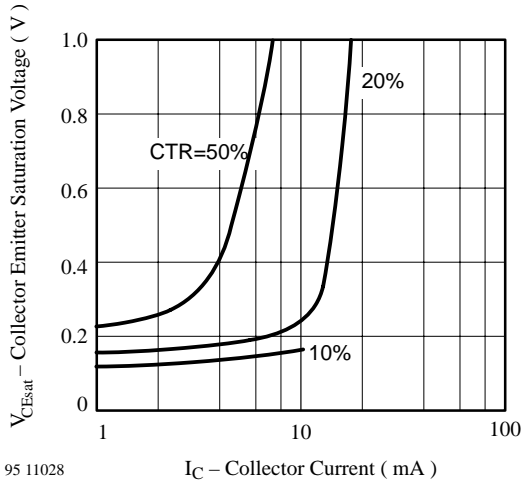

95 11028 I_C – Collector Current (mA)
Figure 10. Collector Emitter Saturation Voltage vs. Collector Current

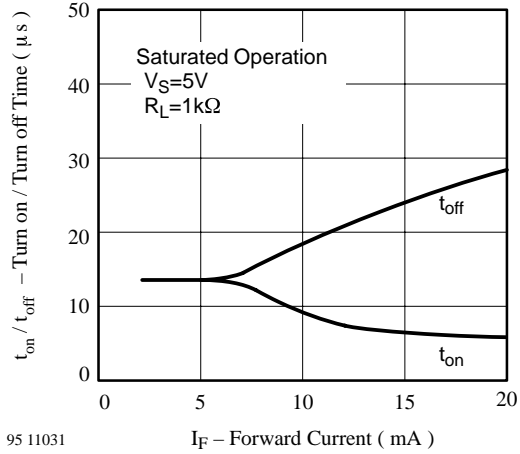

95 11031 I_F – Forward Current (mA)
Figure 12. Turn on / off Time vs. Forward Current

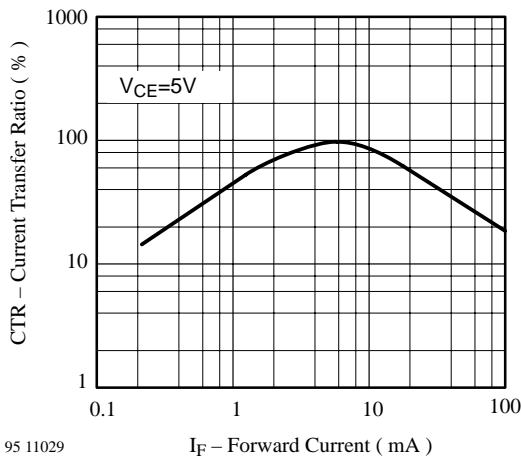

95 11029 I_F – Forward Current (mA)
Figure 11. Current Transfer Ratio vs. Forward Current

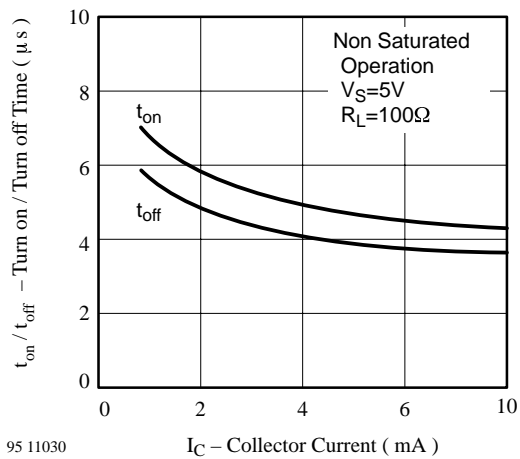

95 11030 I_C – Collector Current (mA)
Figure 13. Turn on / off Time vs. Collector Current

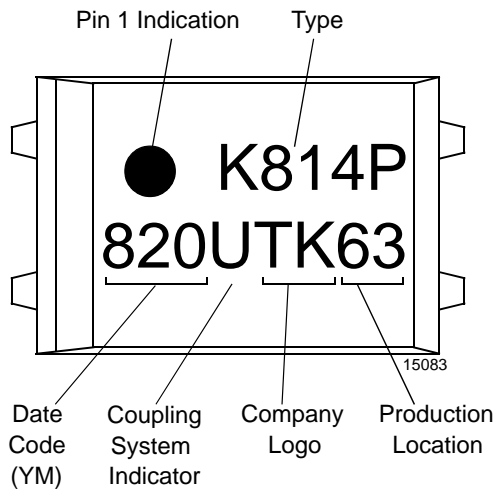
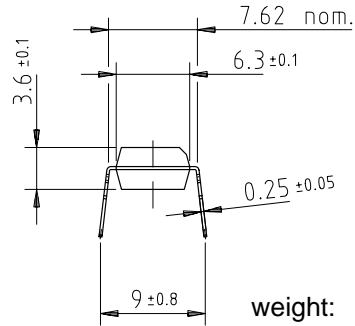
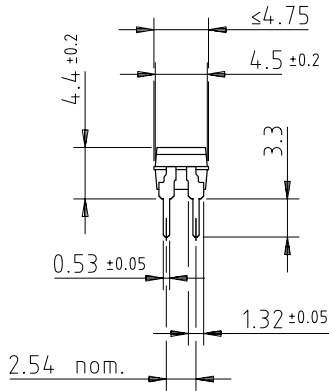

Figure 14. Marking example



Dimensions of K814P in mm



weight: ca. 0.25 g
 creepage distance: ≥ 6 mm
 air path: ≥ 6 mm

after mounting on PC board

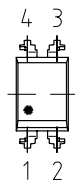

E.g.:
 special Features: endstackable
 to 2.54mm (.100") spacing

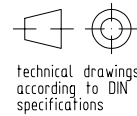
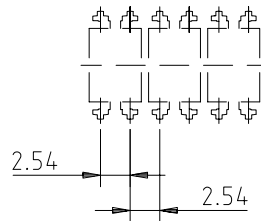

14789

Dimensions of K824P in mm

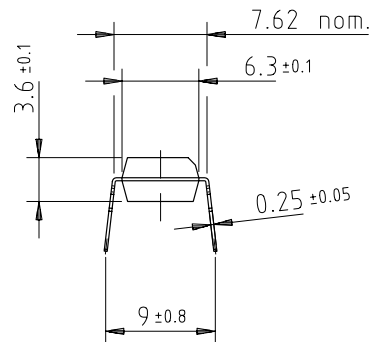
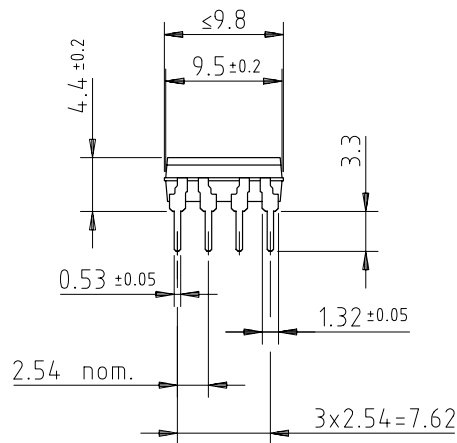

weight: ca. 0.55 g
 creepage distance: ≥ 6 mm
 air path: ≥ 6 mm

after mounting on PC board

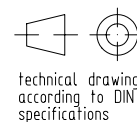
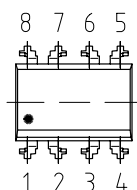

14784

K814P/ K824P/ K844P

Vishay Telefunken



Dimensions of K844P in mm

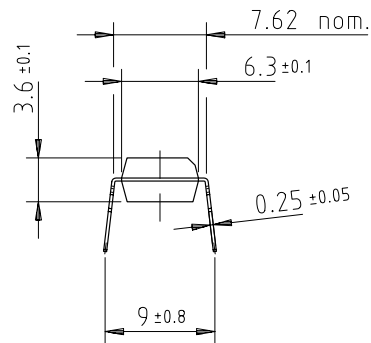
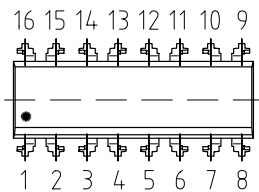
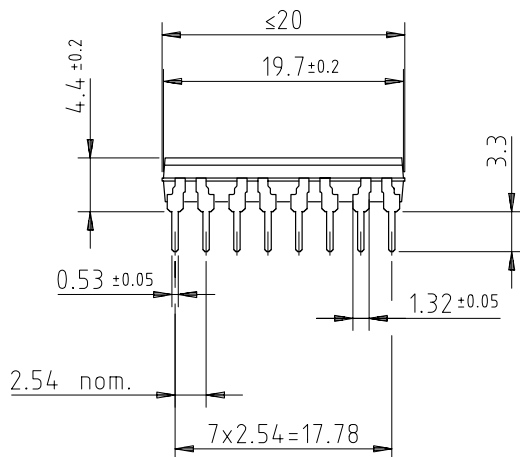

weight: ca. 1.0 g
creepage distance: $\cong 6$ mm
air path: $\cong 6$ mm

after mounting on PC board

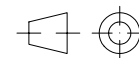

technical drawings
according to DIN
specifications

14783