

**KA2153****LINEAR INTEGRATED CIRCUIT****VIDEO-CHROMA DEFLECTION SYSTEM FOR A COLOR TV (NTSC)**

The KA2153 combines the video-chroma sub-system and the deflection combination on a single monolithic integrated circuit to provide a color television video-chroma deflection system.

This device includes a video amplifier, color demodulator that is designed to provide color differential output, and improved sync separator, horizontal oscillator with saw tooth wave type AFC, horizontal pre-driver with X-ray protection circuit, and vertical oscillator, vertical pre-driver in a 42 leads dual in-line type plastic package.

**FUNCTIONS**

- Inverter-amplifier
- Contrast control
- Pedestal clamp
- Brightness control
- ACC-amplifier
- Tint control
- Uni-color control
- 3.58MHz  $V_{CO}$
- APC
- Color-Killer
- Color demodulator
- Matrix circuit
- Sync-separator (H.V.sync in)
- $2f_H$  horizontal oscillator
- Flip-flop
- Stabilized horizontal  $V_{CC}$  by zener diode
- Horizontal pre driver
- Gate pulse generator
- Vertical sync input
- Vertical oscillator
- Ramp generator

**FEATURES****Video-Chroma Section**

- Minimum numbers of external parts required.
- Stabilized with respect to variation of temperature and supply voltage.
- A few initial adjustment required.

**Deflection Section**

- Excellent temperature stability of horizontal oscillator.
- Exact 50% duty cycle output due to the  $2f_H$  oscillator and flip-flop circuit.
- Excellent inter-race.
- Stable Sync separator with V/H input terminals.

42 DIP

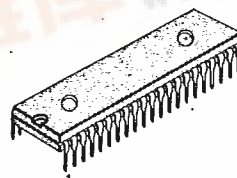

4



SAMSUNG SEMICONDUCTOR

373

**KA2153**

**LINEAR INTEGRATED CIRCUIT**

**BLOCK DIAGRAM**

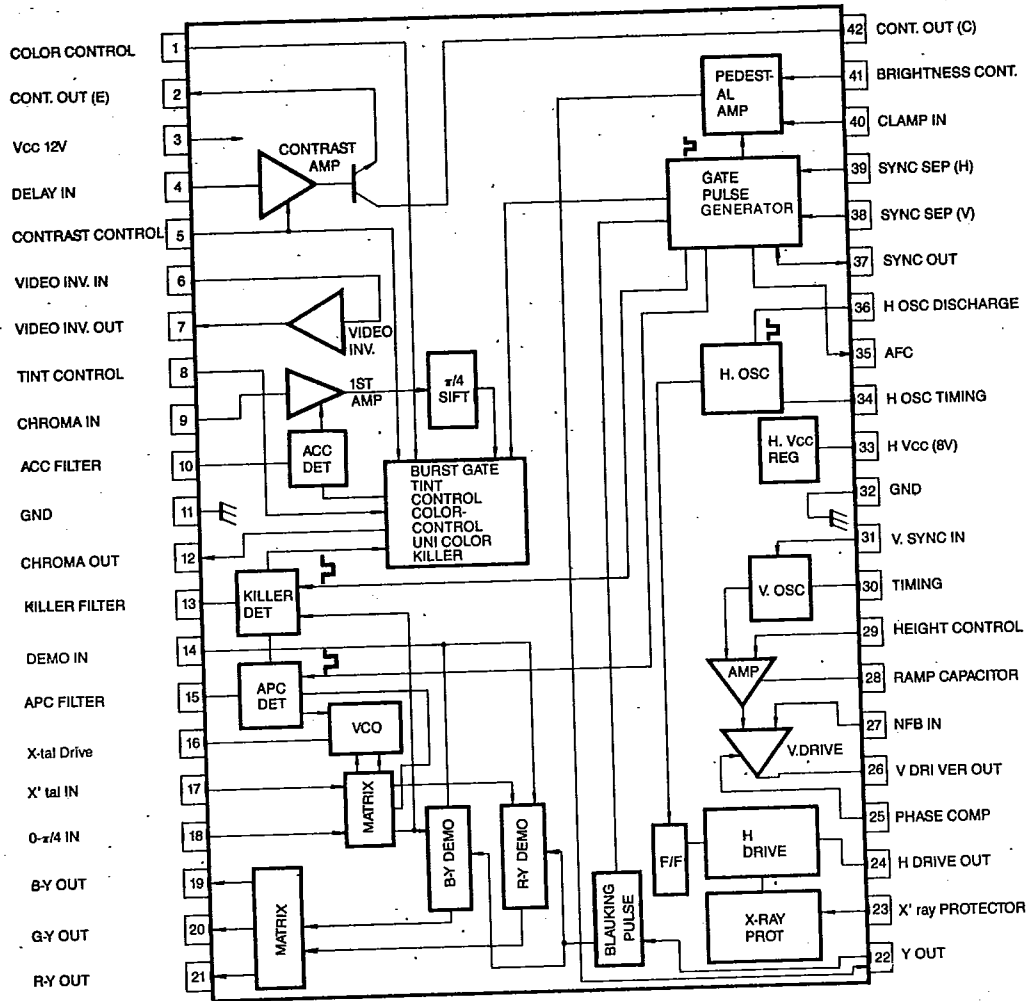

Fig. 1

T-77-07-09

## KA2153

## LINEAR INTEGRATED CIRCUIT

MAXIMUM RATINGS ( $T_a=25^\circ\text{C}$ )

Characteristic	Symbol	Value	Unit
Supply Voltage	$V_3$ Max	15	V
Supply Current	$I_{33}$ Max	40	mA
Input Signal Level	$V_{in}$	5	$V_{p-p}$
Demo. Min. Load Resistance	$R_{LD}$	1.8	$K\Omega$
Horiz. Drive Peak Current	$-I_{24}$ Max	30	mA
Horiz. Drive Operating Current	$-I_{24}$	15	mA
Vert. Output Current	$I_{26}$ Max	-5	mA
Sync separator Input Level	$V_{38}$ Max $V_{39}$ Max	8	$V_{p-p}$
Term. 7 Max. Operating Current	$I_7$	5	mA
Term. 2 Max. Operating Current	$I_2$	4	mA
Power Dissipation (Note)	$P_d$	2.2	W
Operating Temperature	$T_{opr}$	-20 ~ 65	$^\circ\text{C}$
Storage Temperature	$T_{stg}$	-55 ~ 150	$^\circ\text{C}$

Note: Derated above  $T_a=25^\circ\text{C}$  in the proportion of 17.6mW/ $^\circ\text{C}$ .

## ELECTRICAL CHARACTERISTICS

VIDEO SECTION (Unless otherwise specified,  $V_3=12\text{V}$ ,  $T_a=25^\circ\text{C}$ )

Characteristic	Symbol	Test Conditions	Min	Typ	Max	Unit	Test Fig
12V Supply Current	$I_{CC3}$	Measure term. 3 current	60	82	100	mA	1
Video Gain	$U_{22}/U_6$	$V_6=4.25\text{V}$ , $v_6: 4.0\text{MHz}$ , $1.0V_{p-p}$ , $V_5=10\text{V}$ , $V_B=8.0\text{V}$	2.0	3.5	5.0	dB	2
Contrast Gain Control Range	$\Delta G_V$	$V_6=4.25\text{V}$ , $v_6: 500\text{KHz}$ , $1.0V_{p-p}$ , $V_5: 5 \sim 10\text{V}$ $20 \log (V_{22}(\text{max})/V_{22}(\text{min}))$	11.2	12.3	13.4	dB	2
Video Frequency Characteristics	$\Delta G_{VF}$	$V_6=4.25\text{V}$ , $V_5=10\text{V}$ , $V_B=8.0\text{V}$ $v_6=4.0\text{MHz}$ , $0.5\text{MHz}$ $1.0V_{p-p}$ $20 \log (V_{22}(4\text{MHz})/V_{22}(0.5\text{MHz}))$	-3.5	-1.5	0.5	dB	2
DC Restoration Ratio	K	$V_{41}=4.1\text{V}$ Change APL 10% to 90% Measure pedestal level change of term. 22	63	70	77	%	2
Maximum Video Output	$U_V$ MAX.	Term. 5 open. change $V_{40}$ DC voltage, measure 90% of voltage change at term. 22	5.0	7.5	—	$V_{p-p}$	2



T-77-07-09

KA2153

## LINEAR INTEGRATED CIRCUIT

ELECTRICAL CHARACTERISTICS  
VIDEO SECTION (Unless otherwise specified,  $V_3=12V$ ,  $T_a=25^\circ C$ )

Characteristic	Symbol	Test Conditions	Min	Typ	Max	Unit	Test Fig
Video DC Output Therm. Co-effc.	$\partial V_{22}/\partial T$	$V_6=3.25V$ , $V_{d1}=4.1V$ $T_a=-20 \sim +65^\circ C$	-2.5	0	2.5	mV/ $^\circ C$	2
Inverter Amplifier Gain	$V_7/V_6$	$V_6=4.25V$ , $v_6: 4.0MHz$ , $1.0V_{p-p}$ , $V_5=10V$ , $V_8=8.0V$	2.2	3.5	4.6	dB	2
Inverter Amplifier Differential Gain	$DG_R$	$V_6: 3.3 \sim 5.2V$ $v_6: 3.58MHz$ , $100mV_{p-p}$	—	2.5	10	%	2
Inverter Amplifier Differential Phase	$DP_R$	The same condition as above	—	3	5	deg	2
Inverter Amplifier Frequency Characteristics	$\Delta G_{RI}$	$V_6=4.25V$ , $V_5=10V$ , $V_8=8.0V$ , $v_6: 4.0MHz$ , $500KHz$ , $1.0V_{p-p}$ 20 log $v_7(4MHz)/v_7(0.5MHz)$	-3.5	-0.1	0.5	dB	2
Inverter Amplifier 3.58MHz Linearity	$L_7$	$V_6=4.0V$ , $v_6=3.58MHz$	1.6	—	—	$V_{p-p}$	2

## CHROMA SECTION

(Unless otherwise specified. Gate Pulse and Blanking Pulse of TEST CIRCUIT 2 is Applied)

Characteristic	Symbol	Test Conditions	Min	Typ	Max	Unit	Test Fig
Maximum Chroma Output	$V_{CM}$	$V_1=12V$ , $V_5=10V$ , $V_8$ : open $v_9: 120mV_{p-p}$ (B:C=1:1) $V_G=8V$ , $V_B=15V$ , measure term. 12	0.5	0.75	1.05	$V_{p-p}$	3
Burst Output	$V_B$	The same condition as above	0.45	0.70	0.95	$V_{p-p}$	3
ACC Characteristics (1)	$V_a$	$V_1=12V$ , $V_5=10V$ , $V_8$ : open $v_9=15mV_{p-p}$ (B:C=1:1) Measure chroma amplitude term. 12	0.16	0.34	—	$V_{p-p}$	3
ACC Characteristics (2)	A	$V_9=100mV_{p-p}$ , $300mV_{p-p}$ (B:C=1:1) Chroma amplitude ratio at term. 12 $A = \frac{V_{12}(V_9=300mV_{p-p})}{V_{12}(V_9=100mV_{p-p})}$	—	1.0	1.3	—	3
Color Control Residual Signal	$V_{CS}$	$V_1=0V$ , $V_5=10V$ , $V_8$ : open $S_1: 1$ , $S_2: 1$ , $V_G=8V$ , $V_B=15V$ , $v_9=120mV_{p-p}$ (B:C=1:1)	—	—	3	mV $_{p-p}$	3

## KA2153

## LINEAR INTEGRATED CIRCUIT

## CHROMA SECTION

(Unless otherwise specified. Gate Pulse and Blanking Pulse of TEST CIRCUIT 2 is Applied)

Characteristic	Symbol	Test Conditions	Min	Typ	Max	Unit	Test Fig
Uni Color Control Gain Range	$\Delta\theta_{CU}$	$V_1=12.0V, V_5=5\sim 10V,$ $V_8: \text{open}, S_1: 1, S_2: 1,$ $V_G=8V, V_B=15V$ $v_9=120mV_{P-P} (B:C=1:1)$	7.5	8.5	9.5	dB	3
Uni Color Control Phase Range	$\Delta\theta_{cu}$	The same as above. Burst chromia phase change at term. 12	—	4	10	deg	3
HUE Phase Control Range (1)	$\Delta\theta_{bH1}$	$V_1=12V, V_5=10V,$ $V_8=0\sim 12V, v_9=120mV_{P-P},$ $V_G=8V, V_B=15V$ Burst chroma phase change at term. 12 $S_1:1, S_2:1$	75	105	—	deg	3
HUE Phase Control Range (2)	$\Delta\theta_{bH2}$	The same as above. Phase change from $V_8$ open	37	51	62	deg	3
Color Control Phase Change	$\Delta\theta_{CC}$	$V_1=0\sim 12V, V_5: \text{open},$ $V_8: \text{open}$ $v_9=120mV_{P-P} (B:C=1:1)$ $V_G=8V, V_B=15V, S_1:1, S_2:1$	—	3	5	deg	3
Burst-Chroma Phase Difference	$\Delta\theta_{bc}$	$V_1: \text{open}$ The same as above	-8	0	8	deg	3
APC Pull-in Range	$f_p$	$v_{14}=0.6V_{P-P}$ (Burst) Measure term. 16 frequency Difference between $f_c$ and $f_o$ when APC is out	$\pm 250$	$\pm 350$	—	Hz	3
Killer Sensitivity	$V_{bk}$	$v_{14}$ Burst amplitude when $V_1=2V$ $S_1:1, S_2:2$	18	29	45	$mV_{P-P}$	3
Residual Carrier of Demodulator Output	$V_{car R}$ $V_{car G}$ $V_{car B}$	$v_{14}: \text{AC GND}$ 3.58MHz component at term. 19, 20 and 21. $S_1:1, S_2:2$	—	—	300	$mV_{P-P}$	3
Color Difference Signal Output	$V_{OR}$	$S_1:1, S_2:2$ $v_{14}: 3.56954\text{MHz}, 0.2V_{P-P}$ CW: 3.579545MHz	1.45	1.85	2.3	$V_{P-P}$	3
	$V_{OG}$		0.49	0.62	0.77		
	$V_{OB}$		1.55	1.95	2.42		
Color Difference Signal Relative Output	R-Y/B-Y	The same as above	0.85	0.95	1.05	—	3
	G-Y/B-Y		0.25	0.31	0.38		
Color Difference Signal Maximum Output	$V_{ORM}$	$S_1:1, S_2:2$ $v_{14}: 3.56945\text{MHz}, 1.2V_{P-P}$ CW: 3.579545MHz	4.5	5.5	—	$V_{P-P}$	3
	$V_{OGM}$		1.4	1.8	—		
	$V_{OBM}$		4.5	5.5	—		

T-77-07-09

KA2153

## LINEAR INTEGRATED CIRCUIT

## CHROMA SECTION

(Unless otherwise specified. Gate Pulse and Blanking Pulse of TEST CIRCUIT 2 is Applied)

Characteristic	Symbol	Test Conditions	Min	Typ	Max	Unit	Test Fig
Relative Phase	$\theta_{RY}$	S <sub>1</sub> :1, S <sub>2</sub> :2, V <sub>14</sub> : Burst 0.6V <sub>P-P</sub> Chroma 0.2V <sub>P-P</sub>	100	107	112	deg	3
	$\theta_{BY}$		230	240	250		
Demodulator Band Width	f <sub>BR</sub> f <sub>BG</sub> f <sub>BB</sub>	S <sub>1</sub> :1, S <sub>2</sub> :2 V <sub>14</sub> : 10KHz ~ 5MHz; 0.2V <sub>P-P</sub> -3dB Frequency (0dB; 10KHz)	1.13	1.77	3.16	MHz	3
Blanking Operation Voltage	V <sub>#22B</sub>	S <sub>1</sub> :1, S <sub>2</sub> :2 V <sub>14</sub> : Burst 0.6V <sub>P-P</sub> Chroma 0.2V <sub>P-P</sub> Blanking pulse height when Demo. output is disappear	10.4	11.1	—	V	3
Demodulator Output DC Voltage	V <sub>OR</sub> V <sub>OG</sub> V <sub>OB</sub>	S <sub>1</sub> :1, S <sub>2</sub> :2 V <sub>14</sub> : AC GND	7.00	7.71	8.35	V	1
Demodulator Output Difference Voltage	V <sub>O(R-G)</sub> V <sub>O(R-B)</sub> V <sub>O(B-G)</sub>	The same as above	-0.3	—	0.3	V	1
Demodulator DC Output Thermal Co-efficient	$\Delta V_{OR\theta}$ $\Delta V_{OG\theta}$ $\Delta V_{OB\theta}$	The same as above T <sub>a</sub> = -20°C ~ 65°C	-3	0	2	mV/°C	1
DC Output Voltage Difference Component Thermal Co-efficient	$\Delta V_{O(R-G)\theta}$ $\Delta V_{O(R-B)\theta}$ $\Delta V_{O(B-G)\theta}$	The same as above	-2	0	2	mV/°C	1
Color Control Terminal Voltage	V <sub>1</sub>	Measure term. 1 open circuit voltage	5.4	6.0	6.52	V	1
Uni-color Control Terminal Voltage	V <sub>5</sub>	Measure term. 5 open circuit voltage	6.9	7.5	8.02	V	1
HUE Control Terminal Voltage	V <sub>6</sub>	Measure term. 8 open circuit voltage	5.4	6.0	6.52	V	1

T-77-07-09

## KA2153

## LINEAR INTEGRATED CIRCUIT

## HORIZONTAL SECTION

Characteristic	Symbol	Test Conditions	Min	Typ	Max	Unit	Test Fig
Horizontal $V_{CC}$	$V_{33}$	$V_B = 20.3V$	7.4	8.2	9.0	V	1
Recommendable Supply Current	$I_{33}$	—	22	26	30	mA	1
Horizontal Frequency	$f_H$	$S_{39}:b, S_{38}:b, S_{35}: on, V_x = 4V$	15.069	15.569	16.069	KHz	4
$f_H$ Thermal Drift	$\Delta f_{HT}$	The same as above $T_a = -20 \sim 60^\circ C$	-70	80	230	Hz	4
AFC Clamping Voltage	$V_{CL}$	Measure term. 35 open Circuit Voltage $S_1: on$	3.71	4.20	4.75	V	1
AFC Input Current	$I_{IN35}$	$S_1: on, S_5:2$	2.2	3.62	5.1	mA	1
AFC Output Current	$I_{O35}$	$S_1: on, S_5:1$	2.4	3.99	5.6	mA	1
Horizontal Drive Saturation Voltage	$V_{OL24}$	$S_1: on, S_3: on$ measure $V_{24}$	—	—	0.3	V	1
Horizontal Drive Output Duty Cycle	$T_{O24}$	$S_{39}:b, S_{38}:b, S_{35}: open$ $V_x = 4V, \frac{H \text{ Level Period}}{1 \text{ Cycle Period}} \times 100$ Measure $v_{24}$ wave form	45	50	55	%	4
Oscillator Starting Voltage	$V_{33} (min)$	Minimum $V_{33}$ when output Duty of term. 24 in 50%	—	—	4.0	V	4
Starting Supply Current	$I_{33} (min)$	$V_{33} = 4V$ , Measure $I_{33}$	5.5	8.8	11.5	mA	4
AFC Pull-in Range	$\Delta f_{H \text{ PULL}}$	$S_{38}:a, S_{35}:ON, S_{39}:a$ Changing $V_x$ , measure Pull-in range	—	$\pm 600$	—	Hz	4
AFC Hold-in Range	$\Delta f_{H \text{ HOLD}}$	The same as pull-in range. Measure hold-in range.	—	$\pm 1000$	—	Hz	4
X-ray Protector Voltage Sensitivity	$V_{IN23}$	Measure $V_{23}$ when $V_{24}$ Output becomes L. level. $T_a = 25^\circ C$	0.50	0.88	1.10	V	4
X-ray Protector Current Sensitivity	$I_{IN23}$	Measure $I_{23}$ when $v_{24}$ Output becomes L level. $T_a = 25^\circ C$	0.060	0.178	1.00	$\mu A$	4
X-ray Protector Operating Voltage	$V_{IN23 \theta}$	The same as $V_{IN23}$ $T_a = -20 \sim 65^\circ C$	0.30	0.88	1.28	V	4
X-ray Protector Operating Current	$I_{IN23 \theta}$	The same as $I_{IN23}$ $T_a = -20 \sim 65^\circ C$	0.03	0.178	2.0	$\mu A$	4



T-77-01-09

## KA2153

## LINEAR INTEGRATED CIRCUIT

## SYNC SEPARATOR

Characteristic	Symbol	Test Conditions	Min	Typ	Max	Unit	Test Fig
Syncseparator Sensitivity (1)	$I_{IN39}$	Term. 38: open Measure $I_{39}$ when $V_{37}$ is L→H.	18.1	35.0	113	$\mu$ A	4
Syncseparator Sensitivity (2)	$I_{IN38}$	Term. 39: open Measure $I_{38}$ same as above	13.3	21.4	54.2	$\mu$ A	4
Sync Output H Level	$V_{OH37}$	Term. 38: open	7.04	8.19	9.34	V	4
Sync Output L Level	$V_{OL37}$		0	1.5	2.4	V	4
Sync Clamp Voltage	$V_{CL31}$	Measure $V_{31}$ at $I_{31} = -1mA$	-0.85	-0.63	-0.5	V	4

VERTICAL (Unless otherwise specified,  $V_{CC} = 12V$ ,  $T_a = 25^\circ C$ )

Characteristic	Symbol	Test Conditions	Min	Typ	Max	Unit	Test Fig
Vert Freerunning Frequency	$f_V$	$S_{31}$ : ON, measure term. 28	56	60	64	Hz	4
Retrace Time	$T_r$	Term. 28 output pulse	500	690	850	$\mu$ s	4
$f_V$ Pull-in Range	$\Delta f_{VPULL}$	$S_{31}$ : ON/OFF, term. 30-VR $S_{31}$ : OFF $f_{OSC28} = 60Hz$ $S_{31}$ : ON measure $f_{OSC28}$ $\Delta f_{VPULL} = f_{OSC} 28-60Hz$	11.1	12.1	12.9	Hz	4
Ramp Maximum Voltage	$V_{O28}$	$V_{30} = 6V$ , measure $V_{28}$	7.05	7.65	8.25	V	1
Ramp Maximum Current	$I_{O28}$	$V_{30} = 6V$ , measure $I_{28}$ , $S_6$ : ON	16.7	26.8	48.4	mA	1
Maximum Common Mode Input Voltage	$V_{IH28}$	$S_{26}$ , $S_{27}$ : ON, $V_{30} = 0V$ $V_{28}$ : 6→12V, measure $V_{28}$ when $V_{27}$ is saturate.	11.9	—	—	V	4
Minimum Common Mode Input Voltage	$V_{IL28}$	$V_{28}$ : 6→0V The same as above	—	2.86	3.7	V	4
Terminal 28 Input Current	$I_{I28}$	$S_{26}$ , $S_{27}$ : ON, $V_{30} = 0V$ . Measure $I_{28}$ at $V_{28} = 6V$	0.25	0.98	4.50	$\mu$ A	4
Terminal 27 Input Current	$I_{I27}$	The same as above. Measure $I_{27}$ at $V_{28} = 6V$	0.18	0.94	6.21	$\mu$ A	4
Maximum Vertical Output Voltage	$V_{OH26}$	$S_{26}$ : OFF, $S_{27}$ : ON, $V_{30} = 6V$ Measure $V_{26}$	5.6	6.3	7.2	V	4
Minimum Vertical Output Voltage	$V_{OL26}$	$S_{26}$ , $S_{27}$ : OFF, $V_{30} = 6V$ Measure $V_{26}$	—	—	0.3	V	4
Terminal 29 Bias Voltage	$V_{29}$	Measure $V_{29}$ when $I_{29} = -0.2mA$	3.7	3.9	4.1	V	4





**KA2153**

**LINEAR INTEGRATED CIRCUIT**

**TEST CIRCUIT 1 (DC)**

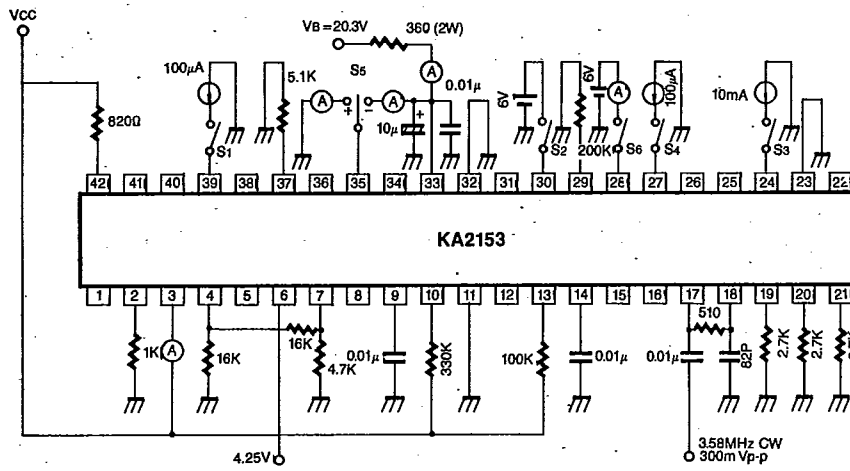

Fig. 2

**TEST CIRCUIT 2 (Video)**

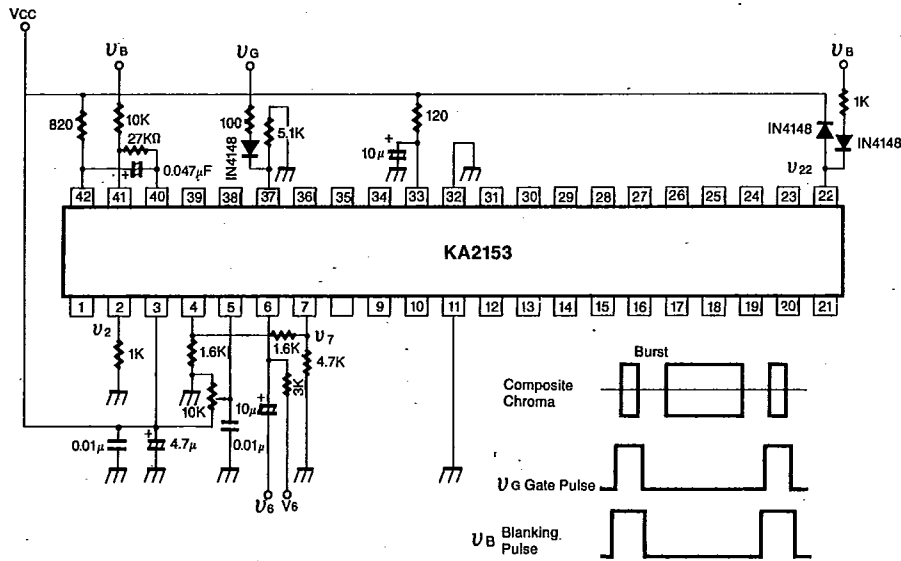

Fig. 3



