

KA2192

4 INPUT A/V SWITCH

4 IN PUT A/V SWITCH

The KA2192 is audio/video 4 input switching IC in the video system for S-VHS(Super-Video Home System).

This device can select audio/video signal of each different 4 kinds input.

This device separates Y(luminance) and C(chroma) for S-VHS.



FUNCTION

- Two input decoder
- Mode selector
- 4 * 1 switch
- Mute switch
- Bias stage
- Gain switch (6dB or 8dB)
- Clamp circuit
- TV polarity switch
- 2 * 1 switch
- Pulse generator
- Switching part for selecting channel

ORDERING INFORMATION

Device	Package	Operating Temperature
KA2192	30-SDIP-400	-20~+65°C

FEATURE

- Independent and stable bias block to prohibit cross talk of and source.
- Available the mode output.
- TV polarity switch can select negative and positive video signal to switch conditions.
- Clamp block for stabile video signal.
- Switch for to control signal gain (6dB or 8dB).
- Separation and Processing of Y(luminance) and C(chroma) for S-VHS video.

BLOCK DIAGRAM

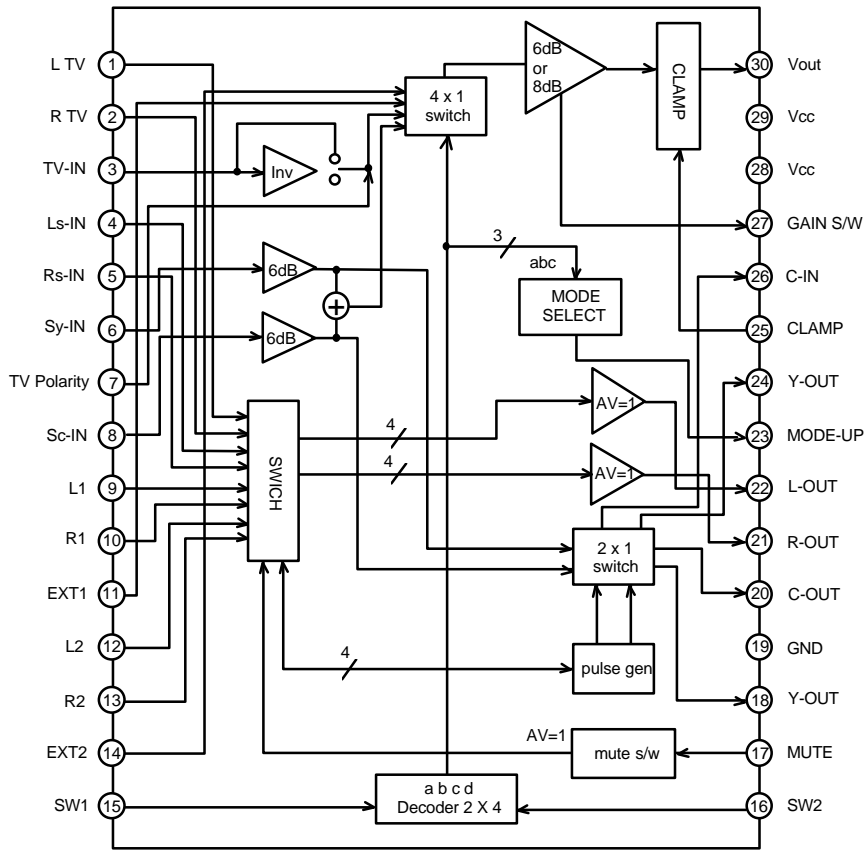

Characteristic	Symbol	Value	Unit
Supply Voltage	V_{CCmax}	15	V
Input Terminal Signal Voltage	V_{Smax}	3	Vp-p
Input Terminal Voltage	V_{INmax}	GND-0.3~VCC+0.3V	-
Power Dissipation	P_{Dmax}	1.6	W
Operating Temperature	T_{OPR}	-20~+70	°C
Storage Temperature	T_{STG}	-55~+150	°C

ABSOLUTE MAXIMUM RATINGS ($T_A=25^\circ\text{C}$)**ELECTRICAL CHARACTERISTICS**

Characteristic	Symbol	Test Conditions	Min	Typ	Max	Unit
Total Current	I_{CC}	$V_{CC}=9V$	21	32	43	mA
Input	V_{DY}	15KHz	1.7	2.2	-	VP-P
	V_{DY}^Y		5.5	6.5	-	
Dynamic Range	V_{DY}^S	Sine Wave	1.9	2.4	-	dB
	G_V		5.6	6.0	7.0	
Video Gain	ΔG_V	15 KHz	0.5	2.0	2.5	dB
	G_{YC}	$1V_{P-P}$	-0.2	0	0.5	
	G_{DY}^S	Sine Wave	5.0	6.0	7.0	
	C_M	4.45 KHz	50	64	-	
Video Crosstalk	C_M	1Vp-p	50	64	-	
Y and C Crosstalk	C_{YC}	Sine Wave	50	64	-	

Characteristic	Symbol	Test Conditions	Min	Typ	Max	Unit
Frequency Width	f_M	1V _{P-P}	10	24	-	MHz
	f_{YC}	Sine Wave	10	39	-	
	f_{YC}		10	24	-	
Clamp Level	C_L	PAL TV Signal	-	21	50	%
Sound Dynamic Range	V_{DY}	1 KHz 1V _{P-P}	5	6	-	V _{P-P}
Sound Gain	G_A	Sine Wave	-0.5	0	0.5	dB
Sound Frequency Characteristics	f_A	1V _{P-P} Sine Wave	100	-	-	KHz
Source Crosstalk	C_A	1 KHz 1V _{P-P}	60	72	-	dB
Source and Channel Crosstalk	C_{LR}	Sine Wave	60	72	-	
Sound Mute Atenuation	M_A		60	75	-	dB
SW 1 Threshold VTG	V_{TH1}		1.0	2.0	3.0	V
SW 2 Threshold VTG	V_{TH2}		1.0	2.0	3.0	
Sound Mute Treshhold VTG	V_{THM}		1.3	2.3	3.3	
TV Polarity s/w Threshold	V_{THP}		-	4.0	-	
Mode Output Voltage	V_M		-	0	0.2	V
	V_M		1.7	2.0	2.3	
	V_M		3.7	4.0	4.5	

ELECTRICAL CHARACTERISTICS(Contiued)

_____	_____
_____	_____
S	
_____	_____
A	
_____	_____

TV
E
S

OPERATING PRINCIPLE

① In-output truth table of A/V switching IC for input switch conditions.

SW INPUT		DECODER OUT				WOUND OUT		VIDEO OUT	Y & C OUT		CODE OUT
SW1	SW2	A	B	C	D	L-OUT	R-OUT	V-OUT	Y OUT	C OUT	MODE OUT
L	L	H	L	L	L	EXT2	EXT2	EXT2	-	-	2(V)
H	L	L	H	L	L	EXT1	EXT1	EXT1	-	-	2(V)
H	H	L	L	H	L	TV	TV	TV	-	-	0(V)
L	H	L	L	L	H	SUPER	SUPER	SUPER	S-Y	S-C	4(V)
L:0(V) H:5(V)		L:0.8(V) H:2.1(V)				SOUND MUTE S/W =HIGH[5] :SOUND OFF		TV POLARITY SW=H $A_V = -1$ GAIN SW =H: 8dB	IF SW1(L) SW2(H) S-Y & S-C OUT		FROM EXT1,2: 2[V] TV:0[V] S-VHS: 4[V]

② Sound mute switch

MUTEIN	SOUND-OUT	
	L-OUT	R-OUT
H [5V]	OFF	OFF
L [0V]	ON	ON

③ Gain switch

GAIN SWITCH	6dB OR 8 dB
H [5V]	8dB
L [0V]	6dB

④ TV polarity switch

TV POLARITY SWITCH	A_V
H [V_{CC}]	$A_V = -1$
L [GND]	$A_V = 1$

TEST CIRCUIT

