

DUAL LOW VOLTAGE POWER AMP

KA2209B

INTRODUCTION

The KA2209B is a monolithic integrated audio amplifier in an 8-pin plastic dualinline package. It is designed for use in portable cassette tape players and radios.

FEATURES

- Wide range of operating supply voltage:
 $V_{CC} = 1.8V \sim 9V$
- Low crossover distortion
- Low quiescent circuit current
- Bridge/stereo configuration

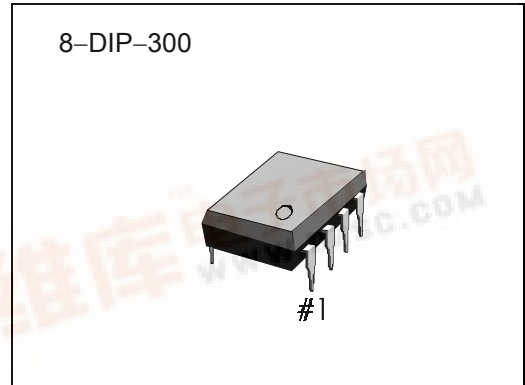

ORDERING INFORMATION

Device	Package	Operating Temperature
KA2209B	8-DIP-300	-20°C ~ +70°C

BLOCK DIAGRAM

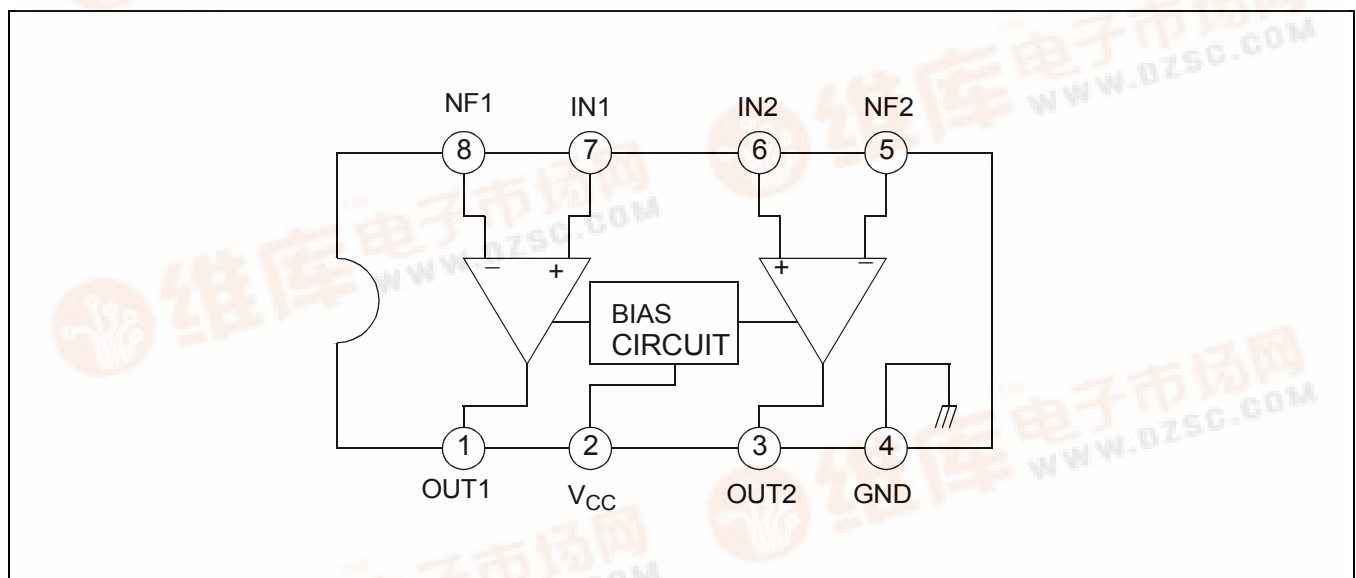

Figure 1.

ABSOLUTE MAXIMUM RATINGS (Ta = 25°C)

Characteristic	Symbol	Value	Unit
Supply Voltage	V _{CC}	15	V
Output Peak Current	I _{PK}	1	A
Power Dissipation	P _D	at T _{AMB} = 50°C 1.0	W
		at T _{CASE} = 50°C 1.4	
Operating Temperature	T _{OPR}	- 20 ~ + 70	°C
Storage Temperature	T _{STG}	- 40 ~ +150	°C

ELECTRICAL CHARACTERISTICS

(Ta = 25°C, Vcc = 6V, f = 1kHz, unless otherwise specified)

Characteristic	Symbol	Test Conditions	Min.	Typ.	Max.	Unit	
Operating Voltage	V _{CC}	–	1.8	–	9	V	
Quiescent Circuit Current	I _{CCQ}	V _I = 0	–	6	–	mA	
Closed Loop Voltage Gain	G _{VC}	Stereo	–	40	–	dB	
		Bridge	–	40	–	dB	
Channel Balance	C _B	Stereo	- 1	0	1	dB	
Output Power	P _O	Stereo	V _{CC} = 6V, R _L = 4Ω, THD=10%	0.4	0.65	–	W
			V _{CC} = 3V, R _L = 4Ω, THD=10%	–	0.11	–	W
		Bridge	V _{CC} = 6V, R _L = 8Ω, THD=10%	0.9	1.35	–	W
			V _{CC} = 3V, R _L = 4Ω, THD=10%	–	0.35	–	W
Total Harmonic Distortion	THD	Stereo, R _L = 8Ω, P _O = 0.2W	–	0.3	–	%	
		Bridge, R _L = 8Ω, P _O = 0.5W	–	0.2	–	%	
Ripple Rejection Ratio	RR	Stereo, f = 100Hz, C ₃ = 100uF	24	30	–	dB	
Output Noise Voltage	V _{NO}	Stereo, BW (-3dB) = 20Hz ~ 20kHz	–	0.5	2.0	mV	
Cross Talk	CT	Stereo, f = 1kHz	–	50	–	dB	
Input Resistance	R _I	–	100	–	–	kΩ	

TEST CIRCUIT 1

STEREO

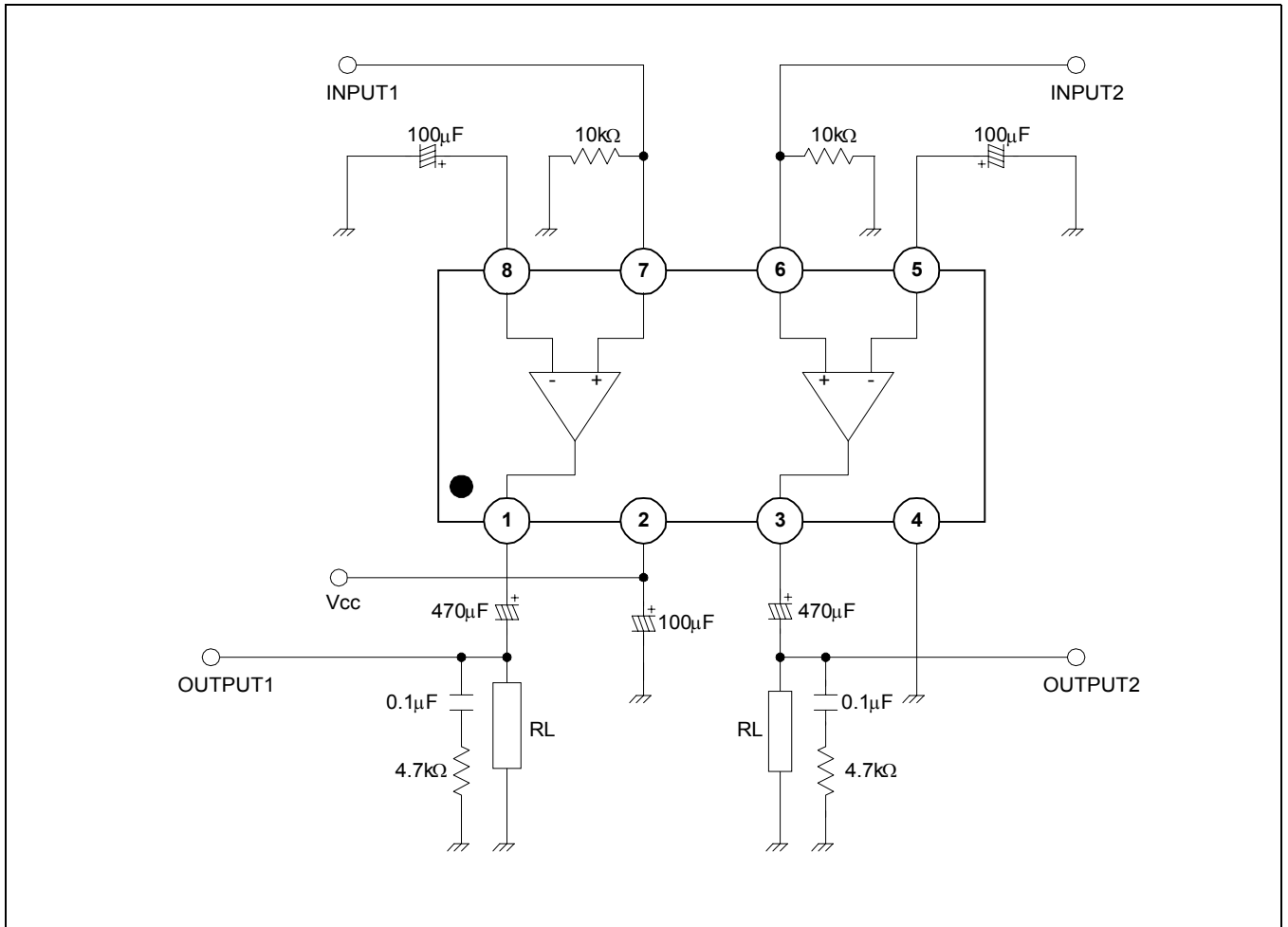

Figure 2.

TEST CIRCUIT 2

BRIDGE

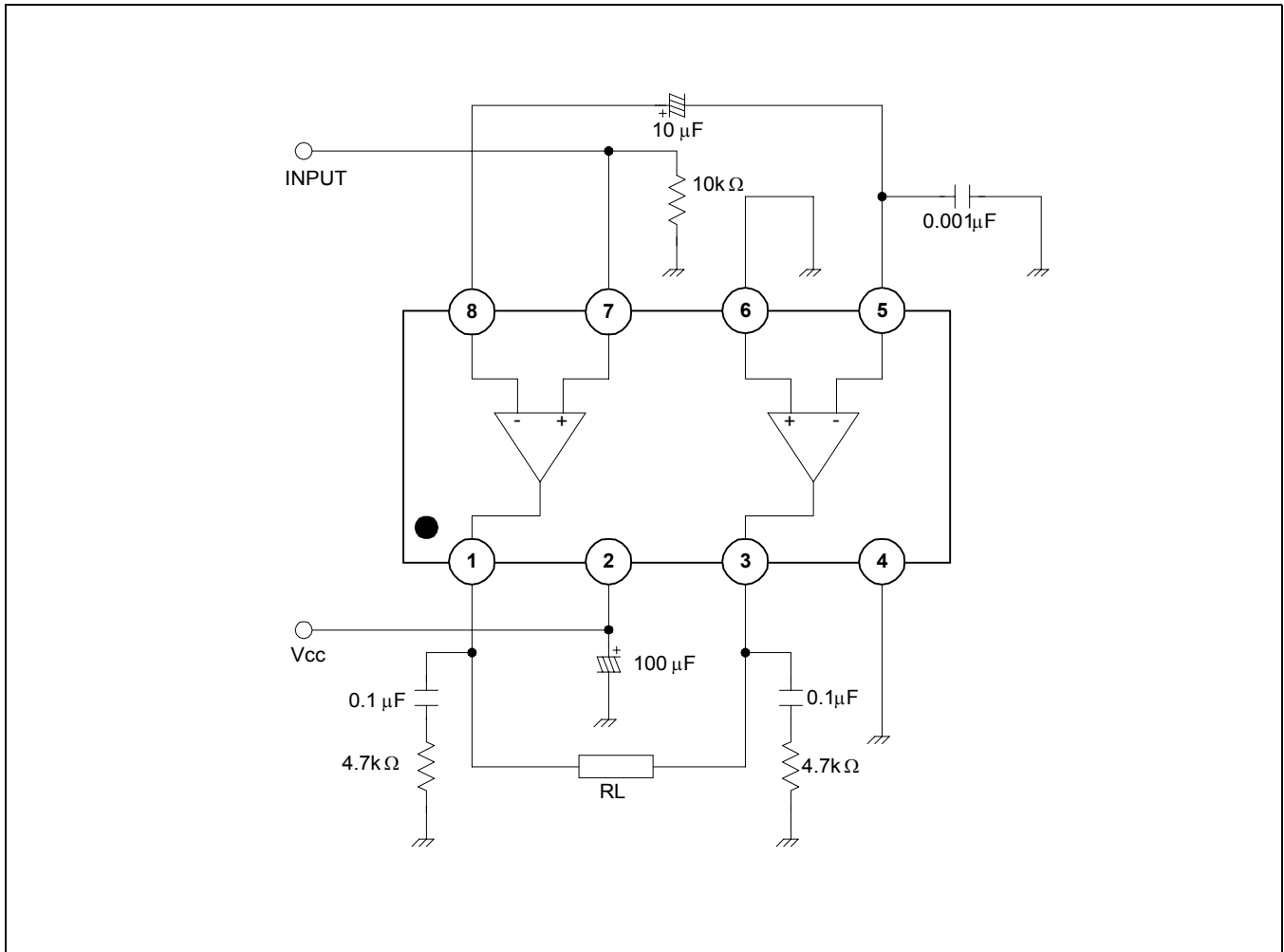

Figure 3.