



INTROCUCTION

The KA22425B is a monolithic integrated circuit designed for radio-cassette tape recorders, clock radios and headphone radios.

FUNCTIONS

- AM/FM RF AMP
- Local OSC
- AM AGO Control
- FM AFO Control
- Audio Power AMP
- Tuning Indicator
- DC Volume
- AM/FM IF AMP
- FM Quadrature DET
- AM DET

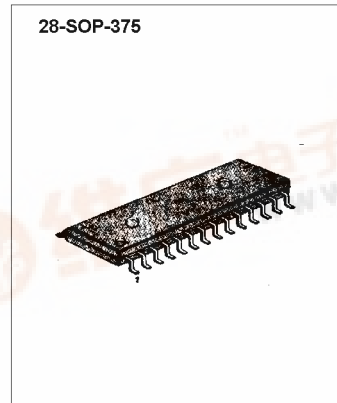

FEATURES

- Built-in AM/FM Switching Circuit
- Wide operating supply voltage: $V_{CC} = 2 \sim 8.5\text{ V}$
- Low current consumption ($V_{CC} = 3\text{V}$)
 - FM: $I_{CCQ} = 7.0\text{mA (tvP)}$
 - AM: $I_{CCQ} = 3.5\text{mA (typ)}$
- High Power Audio Amplifier: 0.5W(typ) at $V_{CC} = 6\text{V}$, $R_L = 8\Omega$, THD = 10%

ORDERING INFORMATION

Device	Package	Operating Temperature
KA22425BD	28-SOP-375	-20 ~ +70 °C

BLOCK DIAGRAM

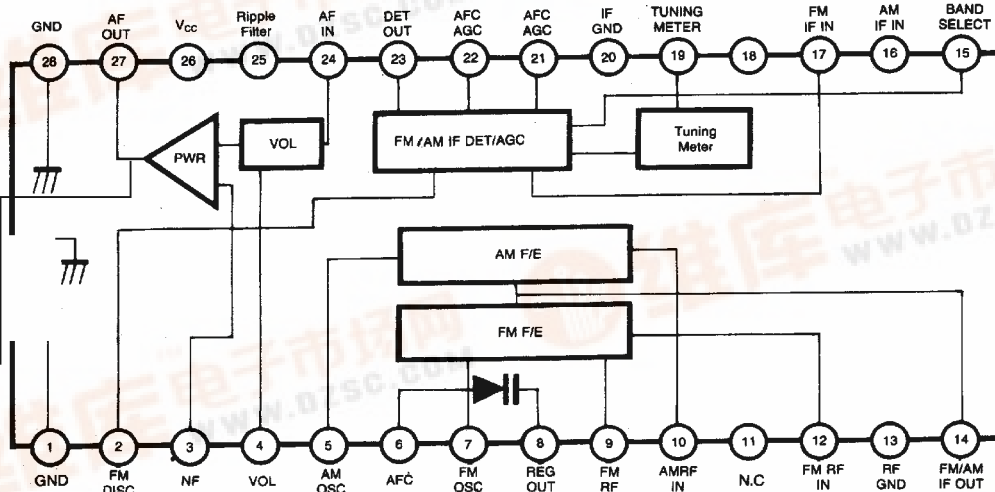

Fig. 1.



ABSOLUTE MAXIMUM RATINGS (Ta = 25 °C)

Characteristic	Symbol	Value	Unit
Supply Voltage	V _{CC}	9	V
Power Dissipation	P _D	1000	mW
Operating Temperature	T _{OPR}	-20 ~ +70	°C
Storage Temperature	T _{STG}	-40 ~ +125	°C

ELECTRICAL CHARACTERISTICS

 (V_{CC} = 6V, Ta = 25 °C, FM; Δf = 22.5KHz, fm = 1KHz, AM; 30% Mod unless otherwise specified)

	Characteristic	Symbol	Test Condition	Min	Typ	Max	Unit
FM	Quiescent Circuit Current	I _{CCQ}	V _I = 0		7.0	14.0	mA
	F/E Voltage Gain	G _{V1V}	V _I (1) = 40dB μ, f = 100MHz, Δf = 0	32	39	46	dB
	Detect Output Gain	V _O (1)	V _I (3) = 90dB μ, f = 10.7 MHz	-26	-20	-14	dBm
	IF-3dB Sensitivity	V _{I(LIM)}	V _O (V _I 3) = 90dBμ -3dB, f = 10.7 MHz		24	32	dB μ
	Total Harmonic Distortion	THD ₁	V _I (3) = 90dB μ, f = 10.7MHz (Δf = 75KHz)		0.3	2.0	%
	Meter Drive Current	I _M (1)	V _I (3) = 60dB μ, f = 10.7MHz	1.8	3.5	7.0	mA
AM	Quiescent Circuit Current	I _{CCQ} (2)	V _I = 0		3.5	10.0	mA
	F/E Voltage Gain	G _V (2)	V _I (2) = 60dB μ, f = 1660KHz, m=0%	15	22	29	dB
	IF Voltage Gain	G _V (3)	V _O (3) = -34dBm, f = 455kHz	14	20	27	dB μ
	AM Detect Output Voltage	V _O (2)	V _I (3) = 85dB μ, f = 455KHz	-26	-20	-14	dBm
	Total Harmonic Distortion	THD ₂	V _I (2) = 95dB μ, f = 1660KHz, V _{CC} =7.8V		0.6	2.0	%
	Meter Drive Current	I _M (2)	V _I (3) = 85dB μ, f = 455KHz	1.3	3.0	7.0	mA
AF	Closed Loop Voltage Gain	G _V (4)	V _O (4) = 0dBm, f = 1KHz	27	31.5	36	dB
	Total Harmonic Distortion	THD ₃	P _O = 50mW, f = 1KHz		0.3	2.5	%
	Output Power	P _O	R _L = 8 Ω, THD = 10%, f = 1KHz	0.4	0.5		W
	Mute Level	M _L	P _O = mW, V _I (4) = 30dBm 1KHz, V _I (3) = FF	8	15	22	dB

Dimensions in Millimeters

