

KA2263

查询KA2263供应商

LINEAR INTEGRATED CIRCUIT

急出货

FM STEREO MULTIPLEX DECODER

The KA2263 is a monolithic integrated circuit consisting of a phase locked loop FM stereo demodulator. It was designed for use in car stereo, cassette recorder and other equipment.

FEATURES

- Wide operating supply voltage range: $V_{CC} = 3V \sim 12V$
- High pilot lamp ON sensitivity.
 $V_{L(ON)} = 9mV$ (Typ).
- Built-in stereo indicator lamp drive circuit.
Maximum lamp current: 20mA (continuous).
- High channel separation: $CS = 45dB$ (Typ).
- Low distortion
 $THD = 0.08\%$ (Typ) at $V_i = 200mV$.
- VCO stop and stereo lamp turn off are simultaneously operated by connected pin 7 to V_{CC} .
- Minimum number of external parts required.

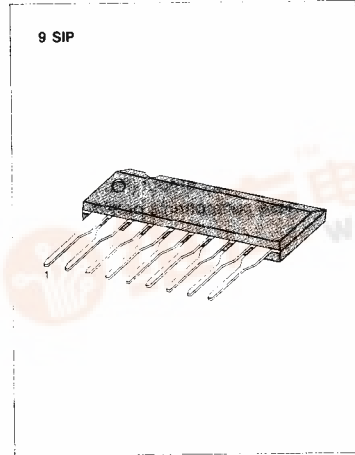

ORDERING INFORMATION

Device	Package	Operating Temperature
KA2263	9 SIP	-20°C ~ +70°C

BLOCK DIAGRAM

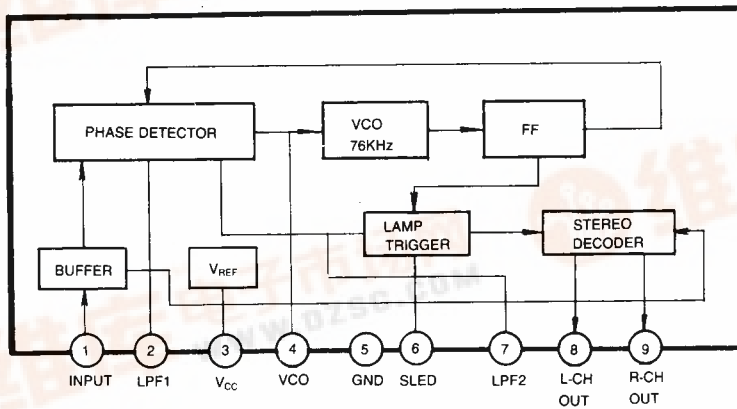

Fig. 1



ABSOLUTE MAXIMUM RATINGS (T_a = 25°C)

Characteristic	Symbol	Value	Unit
Supply Voltage	V _{CC}	12	V
Lamp Voltage	V _{LAMP}	16	V
Lamp Current	I _{LAMP} (CONTINUOUS)	20	mA
Power Dissipation	I _{LAMP(PEAK)} P _D	40 500	mA mW
Operating Temperature	T _{OPR}	-20 ~ +70	°C
Storage Temperature	T _{STG}	-40 ~ +125	°C

*Derated above T_a = 25°C in the proportion of 4mW/°C

ELECTRICAL CHARACTERISTICS

(T_a = 25°C, V_{CC} = 8V, f = 1KHz, unless otherwise specified)

Characteristic	Symbol	Test Conditions	Min	Typ	Max	Unit
Quiescent Circuit Current	I _{CCO}	V _i = 0		11	18	mA
Maximum Input Voltage	V _{i(MAX)}	L + R = 90%, P = 10%, THD = 1%		550		mV
Channel Separation	CS	L + R = 180mV P = 20mV	36	45		dB
Total Harmonic Distortion	Mono	THD 1	V _i = 200mV	0.08	0.3	%
	Stereo	THD 2	L + R = 180mV P = 20mV	0.08		%
Voltage Gain	G _v	V _i = 200mV	-2.0	0	+2.0	dB
Channel Balance	C B	V _i = 200mV		0	1.5	dB
Lamp ON Level	V _{L(ON)}	Pilot only		9	15	mV
Lamp OFF Level	V _{L(OFF)}	Pilot only	2	6		mV
Lamp Hysteresis	HY			3		mV
Carrier Leakage	19KHz	V _{LKG}	L + R = 180mV P = 20mV	34		dB
	38KHz			42		dB

TEST CIRCUIT

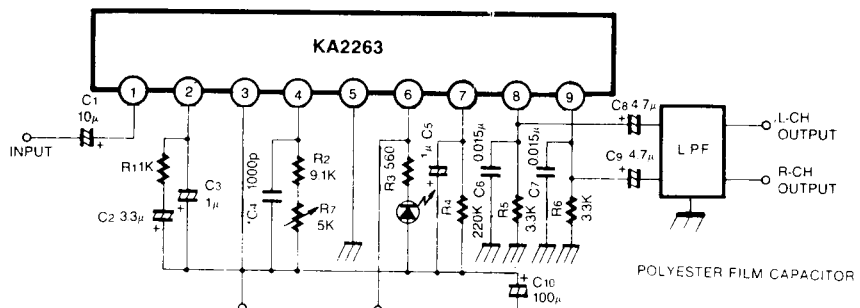
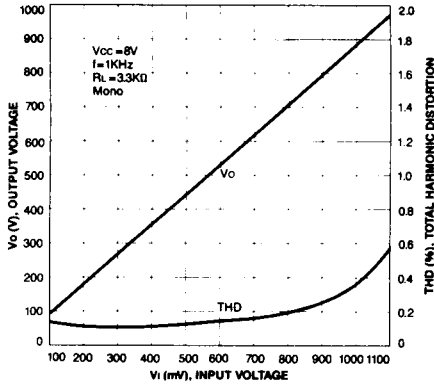
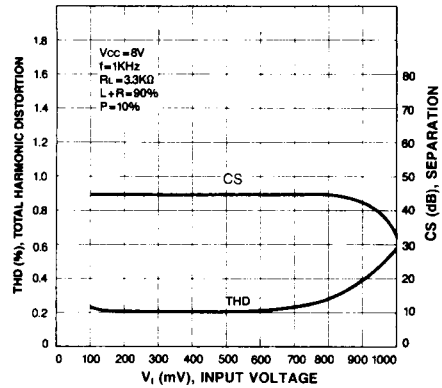

Fig. 2

OUTPUT VOLTAGE
TOTAL HARMONIC DISTORTION — INPUT VOLTAGE



SEPARATION
TOTAL HARMONIC DISTORTION — INPUT VOLTAGE



SEPARATION
TOTAL HARMONIC DISTORTION — FREE RUNNING FREQUENCY

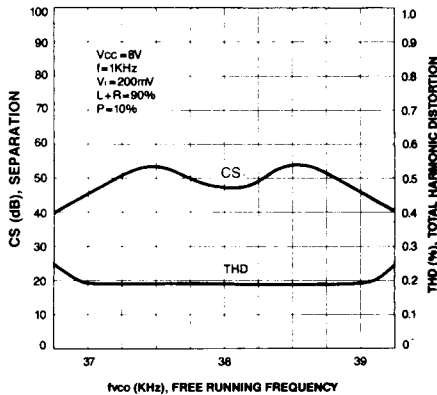

SEPARATION
TOTAL HARMONIC DISTORTION — SUPPLY VOLTAGE

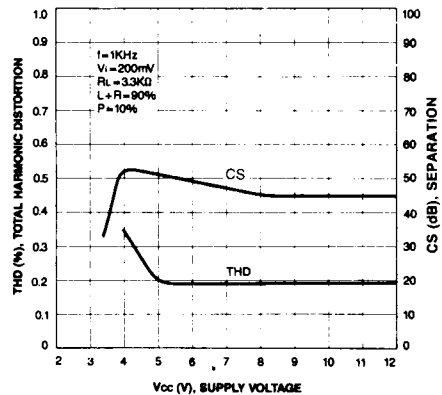

CAPTURE RANGE

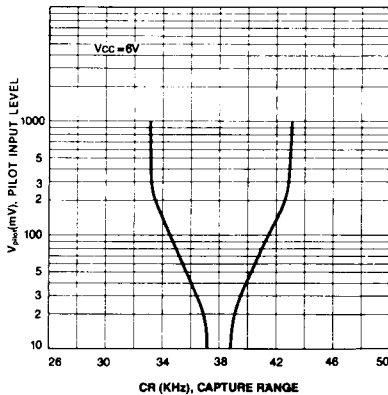

LAMP ON/OFF LEVEL—SUPPLY VOLTAGE

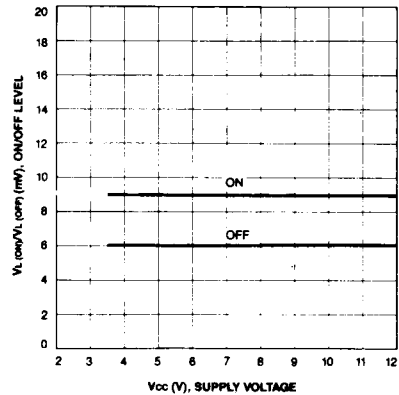

APPLICATION INFORMATION
External Components (Refer to Test Circuit)

1. Input coupling capacitor (C_1)
 The recommended value is $10\mu\text{F}$. If smaller values than $10\mu\text{F}$ are used, low frequency separation will worsen, and if larger values are used, pop noise occurs strongly.
2. Low pass filter (C_2, C_1, R_1)
 This is the low pass filter for the PLL, which is determined the capture range and THD at low frequency.
3. VCO network (C_4, R_2, R_7)
 The VCO free running frequency is adjusted by connecting a frequency counter to monitor the 38KHz output of Pin 6.
4. Decoder output (Pins 8, 9)
 These components provide R and L channel output load circuits. The recommended circuits as follows:

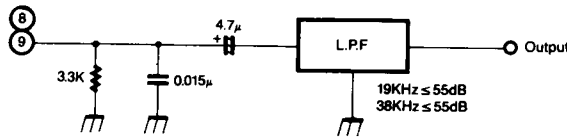
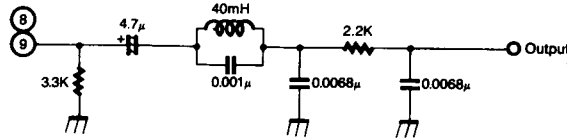

5. Lamp sensitivity control (R_4)
 Lamp on level can be controlled by this resistor.

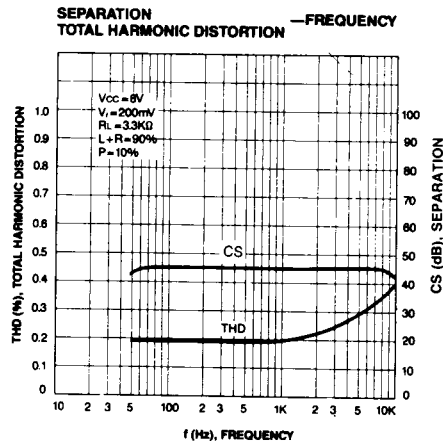
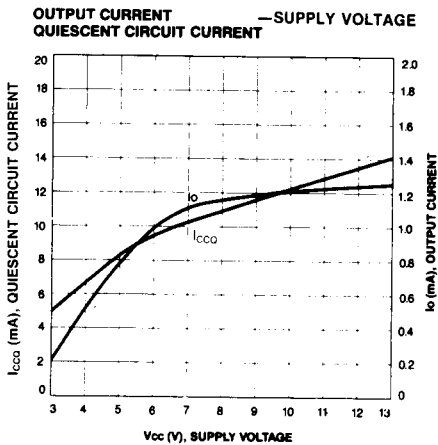

Datasheets for electronics components.