

VCO NON-ADJUSTING FM STEREO MULTIPLEX DECODER

The KA2265 is a monolithic integrated circuit consisting of a VCO non-adjusting FM stereo demodulator with a phase locked loop. It is designed for use in home stereo, portable Hi-Fi.

FEATURES

- Non-adjusting VCO: non-adjusting of free-running frequency.
- Excellent temperature characteristics of VCO: $\pm 0.1\%$ (Typ) at $\pm 50^\circ\text{C}$.
- Excellent stereo high frequency distortion. ($f=10\text{KHz}$: 0.06% (Typ)).
- Excellent distortion: $f=1\text{KHz}$, $V_i=300\text{mV}$, mono: 0.025% (Typ). stereo: 0.02% (Typ)
- High S/N: 91dB (Typ) (mono $V_i=300\text{mV}$, LPF). 92dB (Typ) (mono $V_i=300\text{mV}$, IHF BPF).
- High gain: about 8.5dB.
- Wide dynamic range: mono 800mV ($f=1\text{KHz}$, THD=1%)
- Good ripple rejection: 34dB (Typ).
- Operating voltage range: $V_{CC}=6.5\text{V} \sim 14\text{V}$

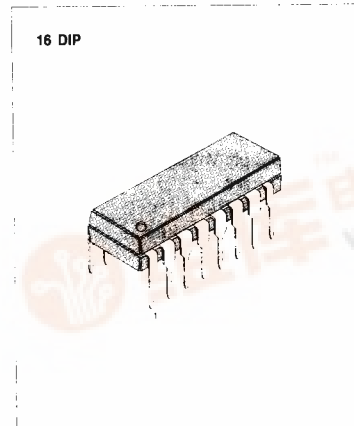

3

ORDERING INFORMATION

Device	Package	Operating Temperature
KA2265	16 DIP	$-20^\circ\text{C} \sim +70^\circ\text{C}$

BLOCK DIAGRAM

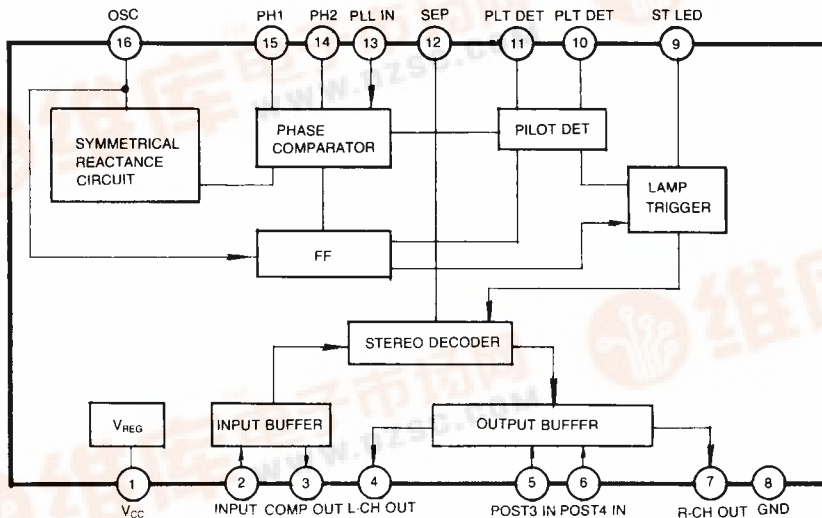

ABSOLUTE MAXIMUM RATINGS ($T_a = 25^\circ\text{C}$)

Characteristic	Symbol	Value	Unit
Power Supply Voltage	V_{CC}	16	V
Lamp Current	I_{LAMP}	30	mA
Power Dissipation	P_D	480	mW
Operating Temperature	T_{OPR}	-20 ~ +70	$^\circ\text{C}$
Storage Temperature	T_{STG}	-40 ~ +125	$^\circ\text{C}$

ELECTRICAL CHARACTERISTICS

(V_{CC} = 12V, f = 1KHz, T_a = 25 $^\circ\text{C}$, unless otherwise specified)

Characteristic	Symbol	Test Conditions	Min	Typ	Max	Unit	
Circuit Current	I_{CC}	$V_i = 0$		18.5	28	mA	
Channel Separation	CS	$P = 30\text{mV}$, $L + R = 270\text{mV}$	40	f = 100Hz	45	dB	
				f = 1KHz	55		
				f = 10KHz	42		
Total Harmonic Distortion	Stereo	THD 1	$P = 30\text{mV}$ $L + R = 270\text{mV}$	f = 100Hz	0.025	0.15	%
				f = 1KHz	0.02	0.15	
	Mono	THD 2	$V_i = 300\text{mV}$	f = 10KHz	0.06		
					0.025	0.15	
Output Voltage	V_O	$V_i = 300\text{mV}$	500	730	1000	mV	
Channel Balance	CB	$V_i = 300\text{mV}$		0	1	dB	
Lamp ON Level	$V_{L(ON)}$	Pilot Level	4	8	17	mV	
Lamp Hysteresis	HY			3		dB	
Capture Range	CR	$P = 30\text{mV}$		+0.8 -1.2		%	
Signal to Noise Ratio	S/N	$V_i = 300\text{mV}$ $R_G = 5.1\text{K}\Omega$	80	91		dB	
Input Impedance	Z_i			20		K Ω	
Maximum Input Level	$V_{I(MAX)}$	Mono, THD=1%	700	800		mV	
Carrier Leakage	V_{LKG}	$P = 30\text{mV}$, $L + R = 270\text{mV}$		31		dB	
VCO Stop Voltage	$V_{STOP(VCO)}$		5.5		$V_{CC} - 3$	V	
Ripple Rejection Ratio	RR			34		dB	

TEST CIRCUIT

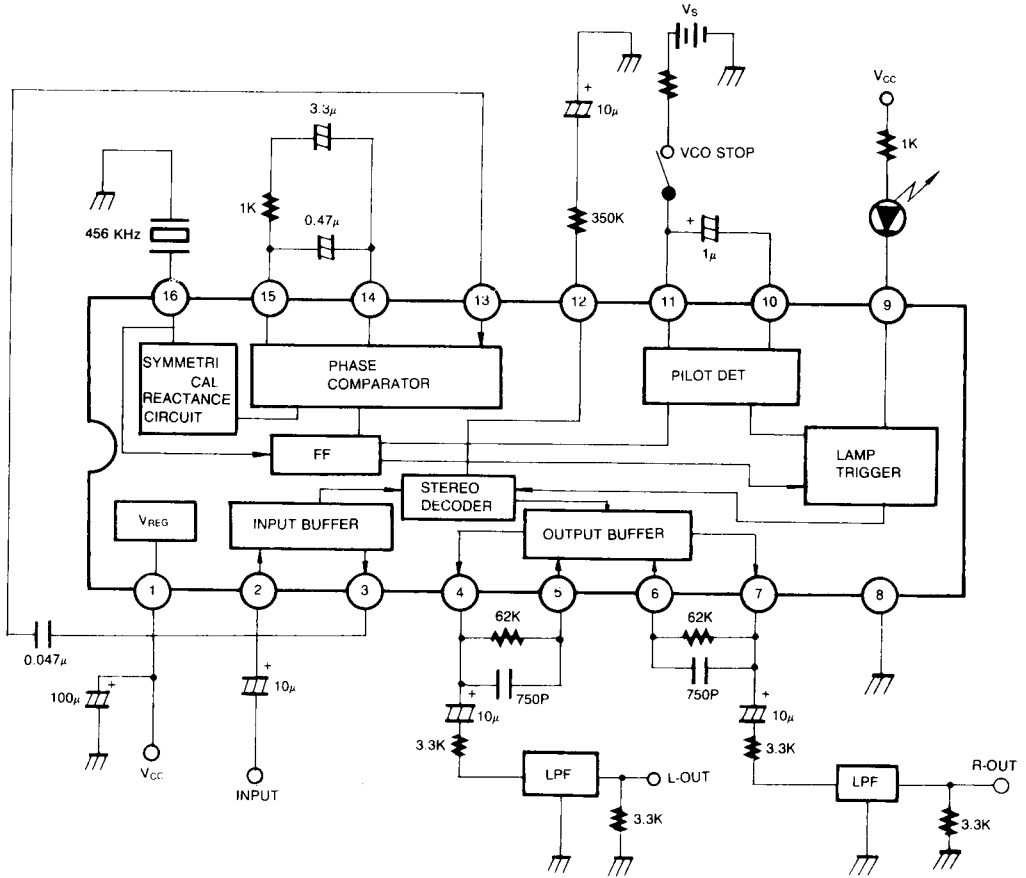

3