

## KA2425A SPEECH NETWORK WITH DIALER INTERFACE

### INTRODUCTION

The KA2425A is telephone speech network integrated circuit which includes transmit amp, receive amp, side tone amp, DC loop interface function, DTMF input, voltage regulator for speech, a regulated output voltage for a dialer, and equalization circuit .

### FEATURES

- Low voltage operation (1.5v : speech)
- Transmit, receive, side tone and DTMF level are controlled by external resistors
- Regulated voltage for dialer
- Loop length equalization
- MUTE function
- Linear interface for DTMF

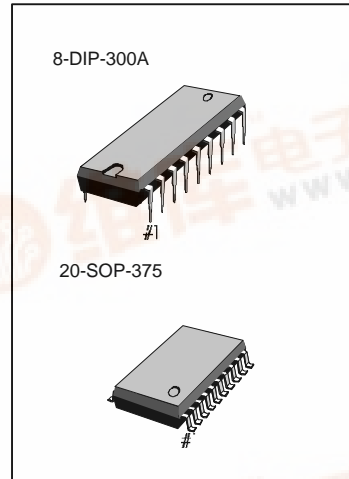

### ORDERING INFORMATION

Device	Package	Operating Temperature
KA2425B	18-DIP-300A	- 20°C ~ + 60°C
KA2425AD	20-SOP-375	

### PIN CONFIGURATION

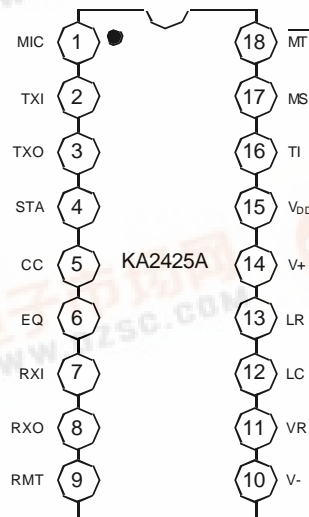

Fig. 1

SAMSUNG

ELECTRONICS

## ABSOLUTE MAXIMUM RATINGS

Characteristic	Symbol	Value	Unit
V <sub>+</sub> Voltage	V <sub>C</sub>	-1.0 ~ +18	V
V <sub>DD</sub> (V <sub>+</sub> = 0)	V <sub>DD</sub>	-1.0 ~ +6	V
MT,MS inputs	V <sub>M</sub>	-1.0 ~ V <sub>DD</sub> +1	V
V <sub>LR</sub>	V <sub>LR</sub>	-1.0V~ V <sub>+</sub> -3.0	V
Storage Temperature	T <sub>STG</sub>	-65 ~ +150	°C

RECOMMENDED OPERATING CONDITIONS (T<sub>a</sub> = 25°C)

Characteristic	Symbol	Value	Unit
I <sub>TXO</sub> (Instantaneous)	I <sub>CC</sub>	0 ~ 10	mA
V <sub>+</sub> (Voltage :Speech Mode)	V <sub>+(SM)</sub>	+1.5 ~ +15	V
Tone Dialing Mode	V <sub>+(TM)</sub>	+3.3 ~ +15	V
Operating Temperature	T <sub>ORR</sub>	-20 ~ +60	°C

ELECTRICAL CHARACTERISTICS (T<sub>a</sub> = 25°C)

Characteristic	Symbol	Test Conditions	Min	Typ	Max	Unit
<b>SYSTEM SPECIFICATIONS</b> (Refer to Fig.3 and Fig.4)						
T <sub>X</sub> Gain from V <sub>S</sub> to V <sub>+</sub>	G <sub>V(TX)</sub>	Figure (I <sub>L</sub> = 20mA) I <sub>L</sub> = 60mA	28	29.5	31	dB
Gain Change	ΔG <sub>V(TX)</sub>		-6.0	-4.5	-3.6	dB
Distortion	THD <sub>TX</sub>		-	2.0	-	%
Output Noise	V <sub>NO(TX)</sub>		-	11	-	dBmc
R <sub>X</sub>	G <sub>V(RX)</sub> ΔG <sub>V(RX)</sub> THD <sub>RX</sub>	f = 1.0KHz, I <sub>L</sub> = 20mA (See Figure.4) I <sub>L</sub> = 60mA	-16	-15	-13	dB
V <sub>RXO</sub> / V <sub>S</sub>			-5.0	-3.0	-2.0	dB
R <sub>X</sub> Gain Change			-	2.0	-	%
Distortion						
DTMF Driver	G <sub>V(MF)</sub>	I <sub>L</sub> = 20mA	3.2	4.8	6.2	dB
Sidetone Level	G <sub>V(ST)</sub>	I <sub>L</sub> = 20mA	-	-28	-	dB
V <sub>RXO</sub> / V <sub>+</sub>		I <sub>L</sub> = 60mA	-	-13	-	dB
Sidetone Rejection	RST	I <sub>L</sub> = 20mA	12	18	-	dB
$\left\{ \frac{V_{RXO}}{V_+} \text{ (Figure 4)} \right\} \text{dB} - \left\{ \frac{V_{RXO}}{V_+} \text{ (Figer 3)} \right\} \text{dB}$						
Tip-Ring Voltage (including polarity guard bridge drop of 1.4v) (Speech Mode)	V <sub>TR</sub>	I <sub>L</sub> = 5.0mA I <sub>L</sub> = 10mA I <sub>L</sub> = 20mA I <sub>L</sub> = 40mA I <sub>L</sub> = 60mA	- - - - -	2.4 3.9 4.6 5.6 6.6	- - - - -	V <sub>DC</sub>
AC impedance	Z <sub>ac</sub>	I <sub>L</sub> = 20mA I <sub>L</sub> = 60mA 20mA < I <sub>L</sub> , 60mA	-	750	-	Ω
Speech mode (incl. C <sub>6</sub> , See Figure 4)			-	300	-	
Z <sub>ac</sub> = (600)V +/ (V <sub>S</sub> - V <sub>+</sub> ) Tone Mode (including C <sub>6</sub> )			-	1650	-	

None : Typicals are tested or guaranteed.

## ELECTRICAL CHARACTERISTICS (Continued)

Characteristic	Symbol	Test Conditions	Min	Typ	Max	Unit
<b>SYSTEM AMPLIFIERS</b>						
$T_X$						
Gain	$G_V(TX)$	TXI to TXO	24	26	28	dB
TXO Bias Voltage	$V_{BIAS(SPM)}$	Speech/Pulse Mode	0.45	0.52	0.60	$xV_R$
TXO Bias Voltage	$V_{BIAS(TM)}$	Tone Mode	$V_R - 25$	$V_R - 5.0$	-	mV
TXO Bias Voltage	$V_{OL(SPM)}$	Speech/Pulse Mode	$V_R - 25$	$V_R - 5.0$	-	mV
TXO Bias Voltage	$V_{OL(SPM)}$	Speech/Pulse Mode	-	125	250	mV
TXI input Resistance	$R_I(TXI)$		-	10	-	$K\Omega$
$R_X$						
RXO Bias voltage	$V_{BIAS(AM)}$	All Mode	0.45	0.52	0.60	$xV_R$
RXO Source current	$I_{SOURCE(SM)}$	Speech Mode	1.5	2.0	-	mA
RXO Source current	$I_{SOURCE(PTM)}$	Pulse/tone Mode	200	400	-	$\mu A$
RXO High Voltage	$V_{OH(AM)}$	All Mode	$V_R - 100$	$V_R - 50$	-	mV
RXO Low Voltage	$V_{OL(AM)}$	All Mode	-	50	150	mV
<b>SIDETONE AMPLIFIER</b>						
Gain (TXO to STA)						
Speech Mode	$G_V(STA)$	@ $V_{LR} = 0.5V$	-	-15	-	dB
Speech Mode		@ $V_{LR} = 2.5V$	-	-21	-	
Pulse Mode		@ $V_{LR} = 0.2V$	-	-15	-	
Pulse Mode		@ $V_{LR} = 1.0V$	-	-21	-	
STA Bias Voltage	$V_{BIAS(STA)}$	All Modes	0.65	0.8	0.9	$xV_R$
<b>MICROPHONE, RECEIVER CONTROLS</b>						
MIC Saturation Voltage	$V_{SAT(MIC)}$	Speech Mode, $I = 500\mu A$	-	50	125	mV
MIC Leakage Current	$I_{LKG(MIC)}$	Dialing Mode, Pin 1=3.0V	-	0	5.0	$\mu A$
RMT Resistance	$R_{RMT(SM)}$	Speech Mode	-	8.0	15	$\Omega$
	$R_{RMT(DM)}$	Dialing Mode	5.0	10	18	$K\Omega$
RMT Delay	$t_D(RMT)$	Dialing to Speech	2.0	4.0	20	ms
<b>EQUALIZATION AMPLIFIER</b>						
GAIN (V + to EQ)						
Speech Mode	$G_V(EQ)$	@ $V_{LR} = 0.5V$	-	-12	-	dB
Speech Mode		@ $V_{LR} = 2.5V$	-	-2.5	-	
Pulse Mode		@ $V_{LR} = 0.2V$	-	-12	-	
Pulse Mode		@ $V_{LR} = 1.0V$	-	-2.5	-	
EQ Bias Voltage	$V_{BIAS(EQ)}$					
Speech Mode	$V_{BIAS(EQ)}$	@ $V_{LR} = 0.5V$	-	0.66	-	$V_{dc}$
Pulse Mode		@ $V_{LR} = 0.5V$	-	1.3	-	
Speech, Pulse Mode		@ $V_{LR} = 2.5V$	-	3.3	-	

## ELECTRICAL CHARACTERISTICS (Continued)

Characteristic	Symbol	Test Conditions	Min	Typ	Max	Unit
<b>DIALING INTERFACE</b>						
$\overline{\text{MT}}$ Input Resistance	$R_{1(\overline{\text{MT}})}$	-	50	100	-	$\text{K}\Omega$
$\overline{\text{MT}}$ Input High Voltage	$V_{\text{IH}(\overline{\text{MT}})}$	-	$V_{\text{DD}}-0.3$	-	-	$V_{\text{dc}}$
$\overline{\text{MT}}$ Input Low Voltage	$V_{\text{IL}(\overline{\text{MT}})}$	-	-	-	1.0	$V_{\text{dc}}$
MS Input Resistance	$R_{1(\text{MS})}$	-	280	600	-	$\text{K}\Omega$
MS Input High Voltage	$V_{\text{IH}(\text{MS})}$	-	2.0	-	-	$V_{\text{dc}}$
MS Input Low Voltage	$V_{\text{IL}(\text{MS})}$	-	-	-	0.3	$V_{\text{dc}}$
TI Input Resistance	$R_{1(\text{TI})}$	-	-	1.25	-	$\text{K}\Omega$
DTMF Gain	$G_{\text{V}(\text{MF})}$	-	3.2	4.8	6.2	dB
<b>LINE INTERFACE</b>						
V+ Current (Pin 12 Grounded)						
Speech Mode	1+	$V_{+} = 1.7\text{V}$	4.5	7.1	9.0	mA
Speech/Pulse Modes		$V_{+} = 12\text{V}$	5.5	8.4	12.5	
Tone Mode		$V_{+} = 12\text{V}$	6.0	8.8	14.0	
V+ Voltage						$V_{\text{dc}}$
Speech/Pulse Mode	V+	$I_{\text{L}} = 20\text{mA}$	2.6	3.2	3.8	
Speech/Pulse Mode		$I_{\text{L}} = 30\text{mA}$	3.0	3.7	4.4	
Speech/Pulse Mode		$I_{\text{L}} = 120\text{mA}$	7.0	8.2	9.5	
Tone Mode		$I_{\text{L}} = 20\text{mA}$	4.1	4.9	5.7	
Tone Mode		$I_{\text{L}} = 30\text{mA}$	4.5	6.4	6.2	
LR Level Shift						$V_{\text{dc}}$
Speech/Pulse Mode	$\Delta V_{\text{LR}}$	$V_{+} - V_{\text{LR}}$	-	2.7	-	
Tone Mode			-	4.3	-	
LC Terminal Resistance	$R_{\text{LC}}$	-	36	57	94	$\text{K}\Omega$
<b>VOLTAGE REGULATORS</b>						
VR Voltage	$V_{\text{R}}$	$(V_{+} = 1.7\text{V})$	1.1	1.2	1.3	$V_{\text{dc}}$
Load Regulation	$\Delta V_{\text{O}}$	$0\text{mA} < I_{\text{R}} < 1.6\text{mA}$	-	20	-	mV
Line Regulation	$\Delta V_{\text{O}}$	$2.0\text{V} < V_{+} < 6.5\text{V}$	-	25	-	mV
$V_{\text{DD}}$ Voltage	$V_{\text{DD}}$	$(V_{+} = 4.5\text{V})$	3.0	3.3	3.8	$V_{\text{dd}}$
Load Regulation (Dialing Mode)	$\Delta V_{\text{O}(\text{DM})}$	$0 < I_{\text{DD}} < 1.6\text{mA}$	-	0.25	-	$V_{\text{dd}}$
Line Regulation (All Modes)	$\Delta V_{\text{O}(\text{AM})}$	$4.0\text{V} < V_{+} < 9.0\text{V}$	-	50	-	mV
Max. Output Current	$I_{\text{OSM}(\text{MAX})}$	Speech Mode	375	550	1000	$\mu\text{A}$
Max. Output Current	$I_{\text{ODM}(\text{MAX})}$	Dialing Mode	1.6	2.0	3.6	mA
$V_{\text{DD}}$ Leakage Current	$I_{\text{LKG}(\text{VDD})}$	$V_{+} = 0, V_{\text{DD}} = 3.0\text{V}$	-	-	1.5	$\mu\text{A}$

# KA2425A

# SPEECH NETWORK WITH DIALER INTERFACE

## TEST CIRCUIT

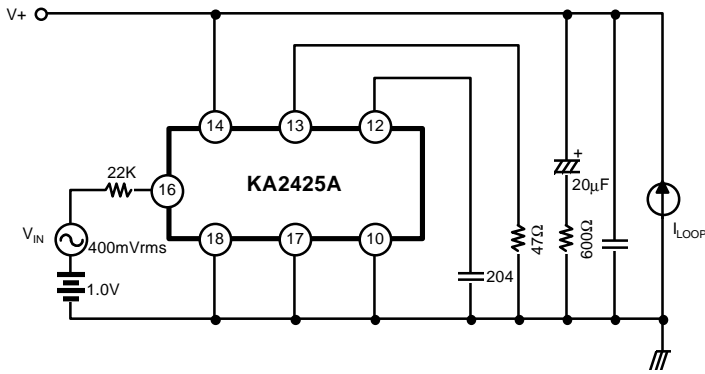

Fig 2. DTMF Driver Test

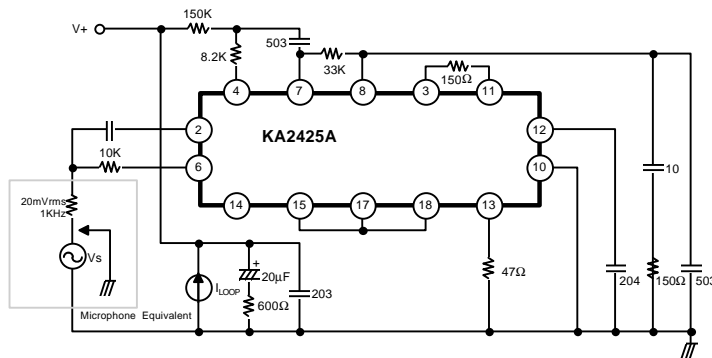

Fig 3. Transmit and sidetone level test

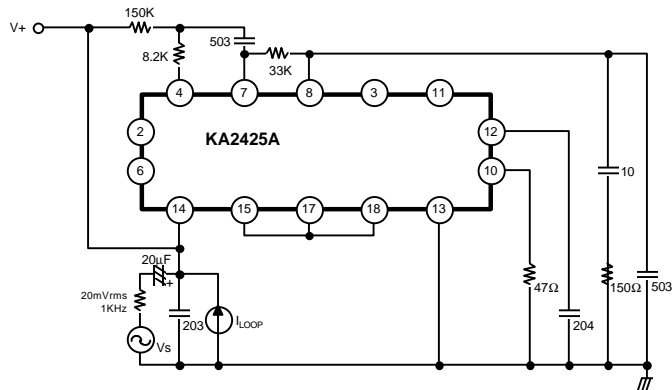

Fig 4. AC Impedance, Receive and Sidetone Rejection Test

# KA2425A

# SPEECH NETWORK WITH DIALER INTERFACE

## APPLICATION CIRCUIT

