

(VIF + SIF) SYSTEM FOR COLOR TV

THE KA2919 is a silicon monolithic integrated circuit containing the VIF section and SIF section on a single chip in the shrink-type 30S DIP package. Since the KA2919 is capable of performing video detection and sound detection independently or simultaneously, it can be applied to various sets from popular types to high-grade types, according to the designer's policy.

FUNCTIONS

VIF

- VIF Amp
- Video Det
- Peak IF AGC
- BW Noise Canceller,
- RF AGC
- AFT
- SIF Det

SIF

- SIF Limiter Amp
- FM Det
- DC ATT
- AF Driver

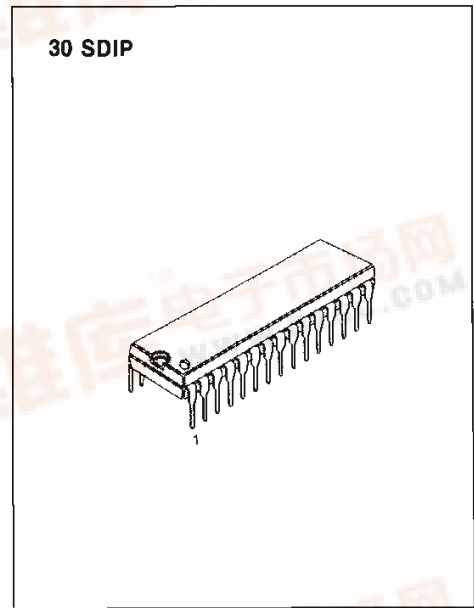

FEATURES

- High-gain VIF amp requiring no preamp
- High AGC speed
- Provides wide-band detection characteristic and meets sound MPX demodulation requirements because of FM detection is quadrature detection
- Possible to use sound REC pin (Pin 2), AUX pin (Pin 3)
- Possible to mute video, sound for VTR
Pin 7 GND: Muting of both video and sound
Pin 29 GND: Muting of sound only

ORDERING INFORMATION

Device	Package	Operating Temperature
KA2919	30 SDIP	-20 ~ +70°C

BLOCK DIAGRAM

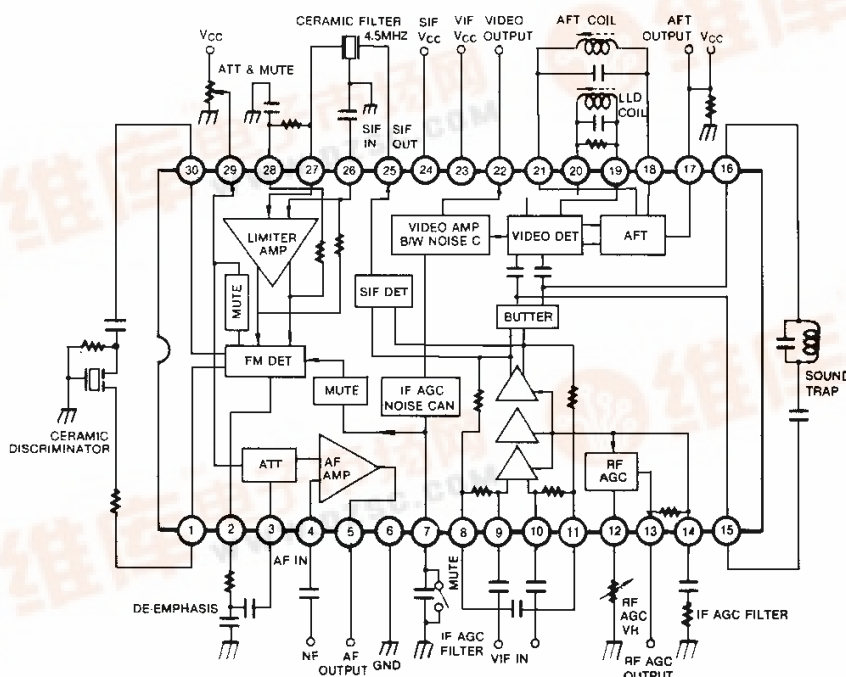

ELECTRICAL CHARACTERISTICS

VIF SECTION ($T_a = 25^\circ\text{C}$, $V_{CC} = 12\text{V}$, $f_p = 45.75\text{MHz}$, $f_s = 41.25\text{MHz}$ (VIF), $f_o = 4.5\text{MHz}$ (SIF))

Characteristics	Symbol	Test Condition	Min	Typ	Max	Unit	Test FIG.
Total Circuit Current	$I_{23} + I_{24}$	DC	59	74	98	mA	1
Maximum RF AGC Voltage	V_{13H}	DC	8.5	8.9	9.2	V	1
Minimum RF AGC Voltage	V_{13L}	DC		0	0.5	V	1
Quiescent Video Output Voltage	V_{22}	DC	5.6	6.1	6.6	V	1
Quiescent AFT Output Voltage	V_{17}	DC	4.5	6.5	7.5	V	1
Input Sensitivity	S_{VI}	$f_m = 400\text{Hz}$ 40% AM, $V_o = 0.8V_{pp}$	30	36	42	$\text{dB}\mu$	2
AGC Range	V_{AGC}	$f_m = 15\text{KHz}$ 78% AM, $V_o = \pm 1\text{dB}$	60	74		dB	2
Maximum Allowable Input	$V_{I\text{MAX}}$	$f_m = 15\text{KHz}$ 78% AM, $V_o = \pm 1\text{dB}$	100	500		mV_{rms}	2
Video Output Amplitude	$V_{O(22)}$	$V_i = 10\text{mV}_{rms}$, $f_m = 15\text{KHz}$ 78% AM	1.9	2.2	2.5	V_{pp}	2
Output S/N	S/N	$V_i = 10\text{mV}_{rms}$ CW	48	54		dB	2
Carrier Leakage	CL	$V_i = 100\text{mV}_{rms}$, $f_m = 15\text{KHz}$ 78% AM	50	57		dB	2
Maximum AFT Voltage	V_{17H}	$V_i = 10\text{mV}_{rms}$ SWEEP	11	11.5	12.0	V	2
Maximum AFT Voltage	V_{17L}	$V_i = 10\text{mV}_{rms}$ SWEEP	0	0.4	1.0	V	2
AFT Detection Sensitivity	S_i	$V_i = 10\text{mV}_{rms}$ SWEEP	70	100	140	mV/KHz	2
White Noise Threshold Level	V_{WTH}	$V_i = 10\text{mV}_{rms}$ SWEEP	6.4	6.8	7.2	V	2
White Noise Clamp Level	V_{WCL}	$V_i = 10\text{mV}_{rms}$ SWEEP	4.2	4.6	5.0	V	2
Black Noise Threshold Level	V_{BTH}	$V_i = 10\text{mV}_{rms}$ SWEEP	1.9	2.2	2.5	V	2
Black Noise Clamp Level	V_{BCL}	$V_i = 10\text{mV}_{rms}$ SWEEP	3.8	4.2	4.6	V	2
SIF Output Signal Voltage	$V_{O(25)}$	P/S = 20dB	40	60	100	mV_{rms}	2
Frequency Characteristic	f_c	-3dB	6	8		MHz	2
Differential Gain	DG	$V_i = 10\text{mV}_{rms}$ 87.5% VIDEOMOD		4	10	%	2
Differential Phase	DP	$V_i = 10\text{mV}_{rms}$ 87.5% VIDEOMOD		3	6	deg	2
Input Resistance	R_i		1.0	1.5	2.0	Kohm	2
Input Capacitance	C_i			3.5	7.0	pF	2

*Electronic Volume Control Characteristic

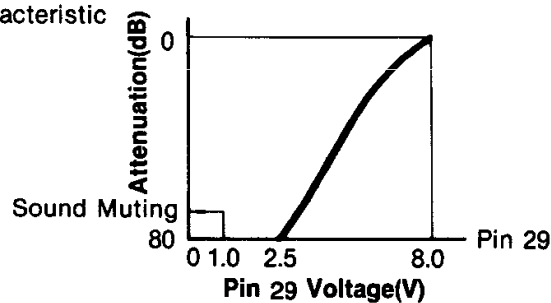

SIF SECTION ($T_a = 25^\circ\text{C}$, $V_{CC} = 12\text{V}$, $f_p = 45.75\text{MHz}$, $f_s = 41.25\text{MHz}$ (VIF), $f_o = 4.5\text{MHz}$ (SIF))

Characteristics	Symbol	Test Condition	Min	Typ	Max	Unit	Test FIG.
SIF Limiting Voltage	$V_{i(LIM)}$	-3dB		200	400	μV_{rms}	2
Detection Output Voltage	$V_o(2)$	$V_i = 100\text{mV}_{rms}$, $f_m = 400\text{Hz}$, $f = \pm 25\text{KHz}$	450	680	850	mV_{rms}	2
Distortion	THD (2)	$V_i = 100\text{mV}_{rms}$, $f_m = 400\text{Hz}$, $f = \pm 25\text{KHz}$		0.5	1.0	%	2
AM Rejection	AMR	$V_i = 100\text{mV}_{rms}$, $f_m = 400\text{Hz}$, $f = \pm 25\text{KHz}$ 30% AM	50	60		dB	2
DCVR Maximum Attenuation	ATT	$V_i = 200\text{mV}_{rms}$, $f = 400\text{Hz}$	70	80		dB	2
AF Amp Gain	G_{AF}	$V_i = 100\text{mV}_{rms}$, $f = 400\text{Hz}$	18	20	22	dB	2
AF Amp Output Voltage	$V_o(5)$	$V_o(5)$ THD = 10%, $f = 400\text{Hz}$	3	4		V_{rms}	2

TEST CIRCUIT

1. DC TEST

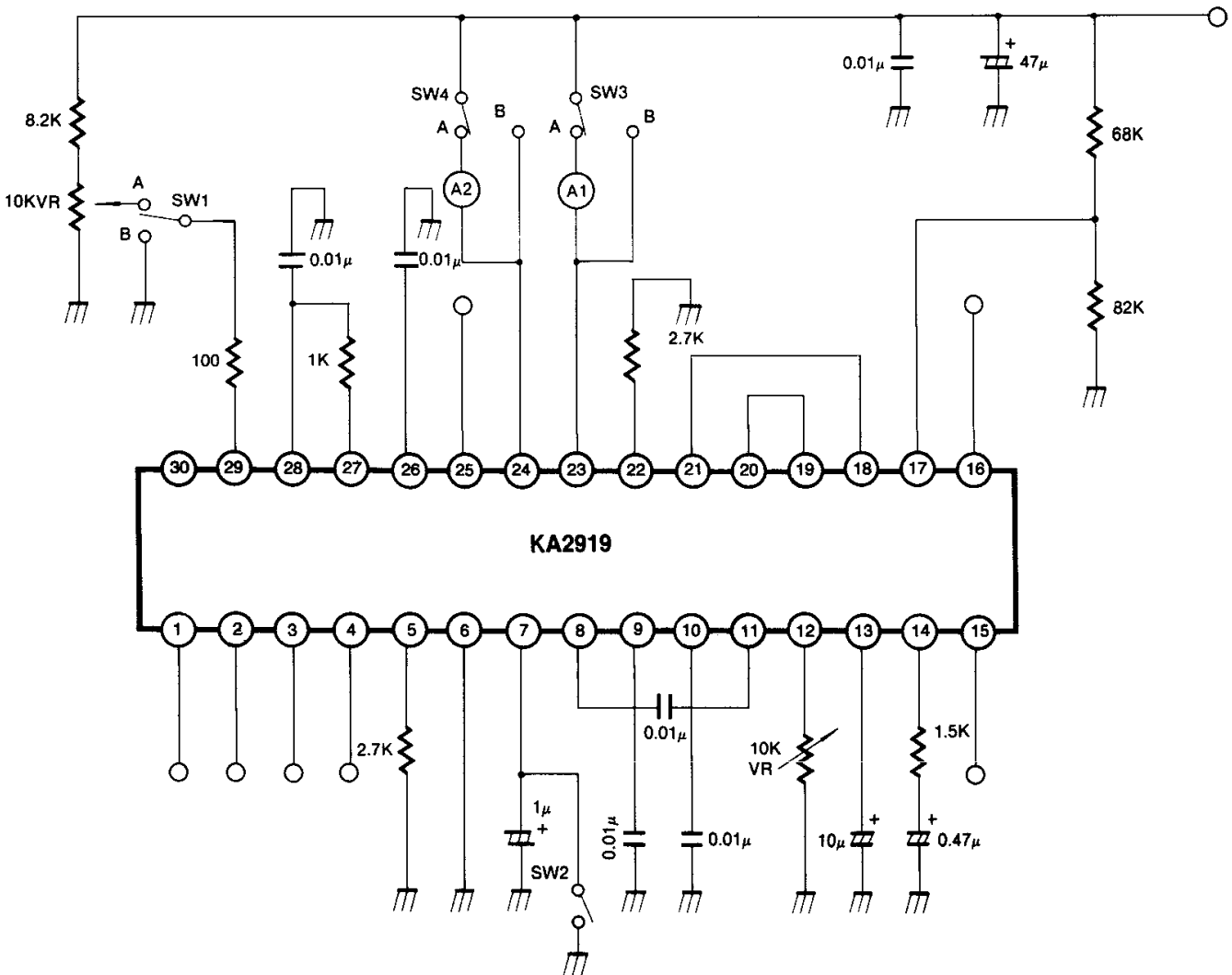

2. AC TEST

