

KA558/KA558B

Quad Timer

Features

- Wide Supply Voltage Range: 4.5V To 16V
- 100 mA Output Current Per Section
- Edge Triggered Without Coupling Capacitor
- Time Period Equals RC
- Output independent Of Trigger Conditions

Applications

- Quad One-Shot
- Sequential Timing
- Precision Timing
- Time Delay Generation

Description

The KA558/KA558B series are monolithic Quad Timers which can be used to produce four entirely independent timing functions. These highly stable, general purpose controllers can be used in a monostable mode to produce accurate time delays, from microseconds to hours. The time is precisely controlled by one external resistor and one capacitor in the time delay mode. A stable mode can be operated using two of four time sections.

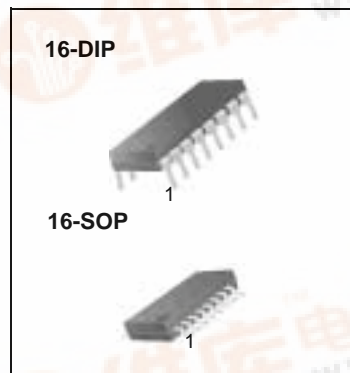

Internal Block Diagram

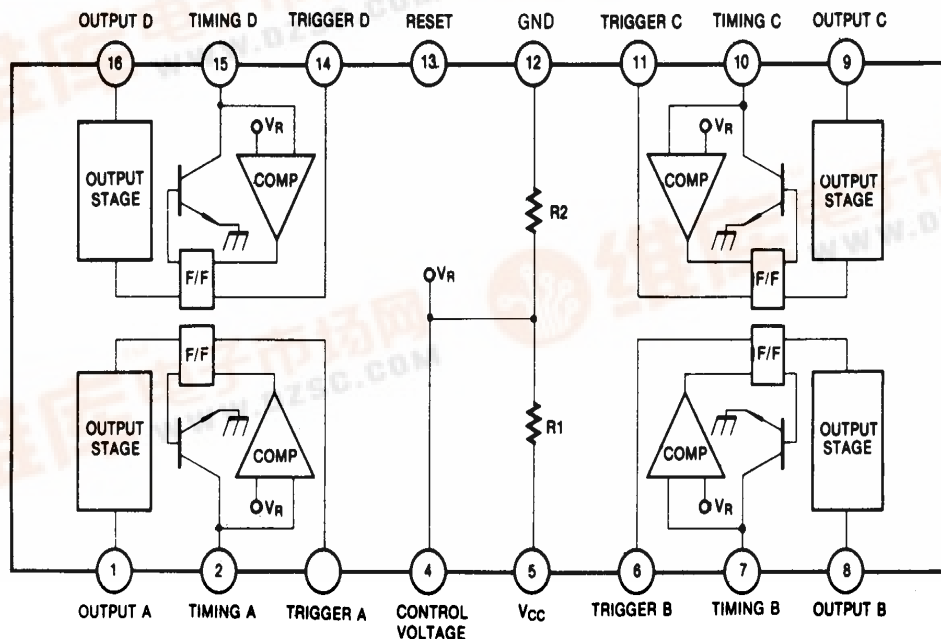

Absolute Maximum Ratings (T_A = 25°C)

Parameter	Symbol	Value	Unit
Supply Voltage	V _{CC}	16	V
Lead Temperature (soldering 10sec)	T _{LEAD}	300	°C
Power Dissipation	P _D	600	mW
Operating Temperature Range KA558/KA558B	T _{OPR}	0 ~ + 70	°C
Storage Temperature Range	T _{STG}	-65 ~ + 150	°C

Electrical Characteristics

(V_{CC} = 5 ~ 15V, T_A = 25°C, unless otherwise specified)

Parameter	Symbol	Conditions	Min.	Typ.	Max.	Unit
Supply Voltage	V _{CC}	-	4.5	-	16	V
Supply Current	I _{CC}	V _{CC} = 15V, reset voltage = 15V	-	16	36	mA
Timing Error (T = RC) Initial Accuracy Drift with Temperature Drift with Supply Voltage	ACCUR Δt/ΔT Δt/ΔV _{CC}	R = 2KΩ to 100KΩ, C = 1μF	-	±2 30 0.1	5 150 0.9	% PPM/°C %/V
*1Trigger Voltage	V _{TR}	V _{CC} = 15V	-	1.5	2.4	V
*1Trigger Current	I _{TR}	V _{TR} = 0V	-	5.0	100	μA
*2Reset Voltage	V _{RST}	-	0.8	1.5	2.4	V
*2Reset Current	I _{RST}	-	-	50	500	μA
Threshold Voltage	V _{TH}	-	0.8	0.63 × V _{CC}	-	V
Threshold Current	I _{TH}	-	-	15	-	nA
*3Output Voltage	V _O	I _L = 10mA I _L = 100mA	- -	0.1 1.0	0.4 2.0	V
Output Leakage Current	I _{LKG}	-	-	10	500	nA
Propagation Delay Time	t _D	-	-	1.0	-	μS
Rise Time	t _R	I _L = 100mA	-	100	-	nS
Fall Time	t _F	I _L = 100mA	-	100	-	nS

Note :

1. The trigger functions only on the falling edge of the trigger pulse only after previously being high. After reset the trigger must be brought high and then low to implement triggering.
2. For reset below 0.8V, outputs set low and trigger inhibited.
3. Output structure is open collector which requires a pull up resistor to V_{CC} to sink current. The output is normally low sinking current.

Mechanical Dimensions

Package

Dimensions in millimeters

16-DIP

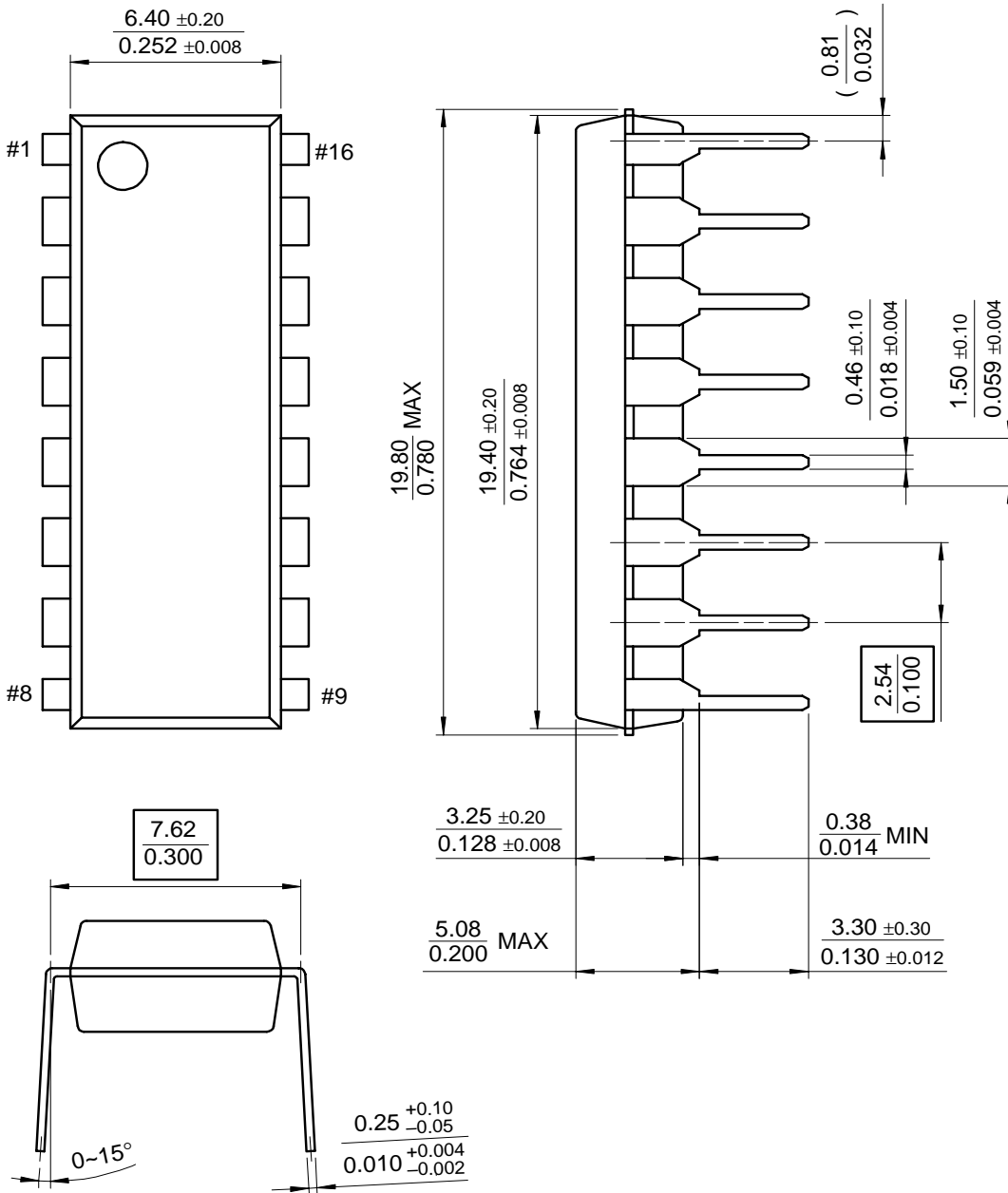

Mechanical Dimensions (Continued)

Package

Dimensions in millimeters

16-SOP

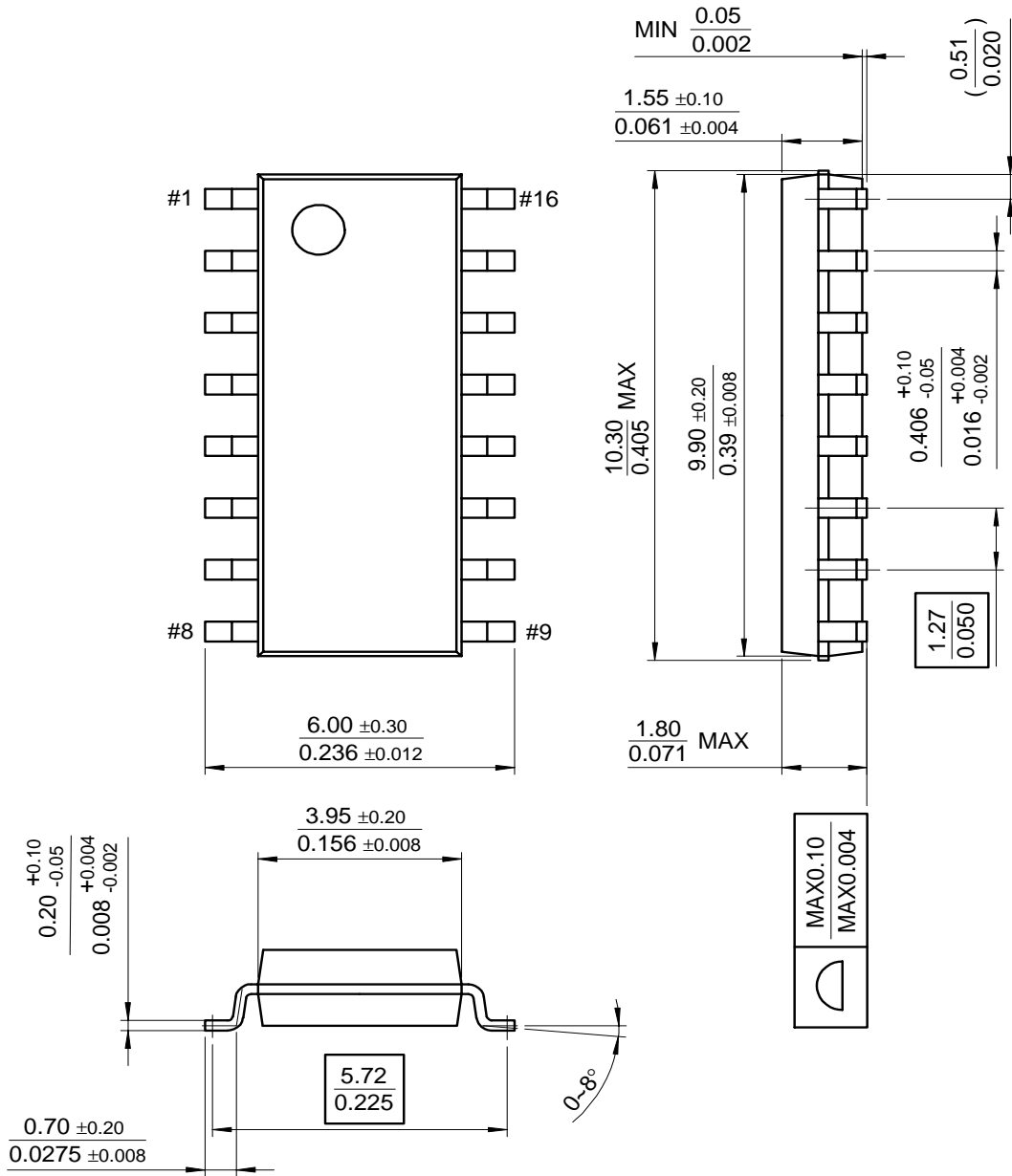

Ordering Information

Product Number	Package	Operating Temperature
KA558B	16-DIP	0 ~ + 70°C
KA558BD	16-SOP	
KA558D2		

DISCLAIMER

FAIRCHILD SEMICONDUCTOR RESERVES THE RIGHT TO MAKE CHANGES WITHOUT FURTHER NOTICE TO ANY PRODUCTS HEREIN TO IMPROVE RELIABILITY, FUNCTION OR DESIGN. FAIRCHILD DOES NOT ASSUME ANY LIABILITY ARISING OUT OF THE APPLICATION OR USE OF ANY PRODUCT OR CIRCUIT DESCRIBED HEREIN; NEITHER DOES IT CONVEY ANY LICENSE UNDER ITS PATENT RIGHTS, NOR THE RIGHTS OF OTHERS.

LIFE SUPPORT POLICY

FAIRCHILD'S PRODUCTS ARE NOT AUTHORIZED FOR USE AS CRITICAL COMPONENTS IN LIFE SUPPORT DEVICES OR SYSTEMS WITHOUT THE EXPRESS WRITTEN APPROVAL OF THE PRESIDENT OF FAIRCHILD SEMICONDUCTOR CORPORATION. As used herein:

1. Life support devices or systems are devices or systems which, (a) are intended for surgical implant into the body, or (b) support or sustain life, and (c) whose failure to perform when properly used in accordance with instructions for use provided in the labeling, can be reasonably expected to result in a significant injury of the user.
2. A critical component in any component of a life support device or system whose failure to perform can be reasonably expected to cause the failure of the life support device or system, or to affect its safety or effectiveness.